

SECURITIES AND EXCHANGE COMMISSION
Release No. 34-78710; File No. 601-01

August 29, 2016

Euroclear Bank SA/NV; Notice of Filing of Application to Modify an Existing Exemption from Clearing Agency Registration

I. Introduction

On May 9, 2016, Euroclear Bank SA/NV (“EB”) filed with the Securities and Exchange Commission (“Commission”) an application on Form CA-1 requesting to modify an existing exemption¹ (“Existing Exemption”) from clearing agency registration (“Modification Application”)² pursuant to Section 17A³ of the Securities Exchange Act of 1934 (“Exchange Act”) and Rule 17Ab2-1 thereunder.⁴ Subject to certain limitations and conditions, the Existing Exemption enables EB as operator of the Euroclear System⁵ to perform the functions of a

¹ See Self-Regulatory Organizations; Morgan Guaranty Trust Company of New York, Brussels Office, as Operator of the Euroclear System; Order Approving Application for Exemption From Registration as a Clearing Agency, Exchange Act Release No. 39643 (Feb. 11, 1998), 63 FR 8232 (Feb. 18, 1998) (“Original Exemption Order”); and Self-Regulatory Organizations; Morgan Guaranty Trust Company, Brussels Office, as Operator of the Euroclear System and Euroclear Bank, S.A.; Order Approving Application to Modify an Existing Exemption From Clearing Agency Registration, Exchange Act Release No. 43775 (Dec. 28, 2000), 66 FR 819 (Jan. 4, 2001) (“2001 Exemption Modification Order”) (together the Existing Exemption).

² The descriptions set forth in this notice regarding the structure and operations of EB have been largely derived from information contained in EB’s amended Form CA-1 application and publicly available sources. The redacted Modification Application and non-confidential exhibits thereto are available on the Commission’s website.

³ 15 U.S.C. 78q-1.

⁴ 17 CFR 240.17Ab2-1.

⁵ “Euroclear System” means the securities settlement system that has been operated by EB or its predecessor since 1968 and the assets, means, and rights related to such services. All services performed by EB that relate to securities settlement and custody are part of the Euroclear System. See Modification Application, Exhibit S-1 at 1.

clearing agency with respect to transactions involving certain U.S. government securities (“U.S. Government Securities”)⁶ for its U.S. participants (“U.S. Participants”)⁷ without registering as a clearing agency (“U.S. Government Securities Clearing Agency Activities”).⁸

In the Modification Application, EB has requested that the Commission broaden the Existing Exemption to permit EB to perform certain additional clearing agency services (such as certain central securities depository (“CSD”) services⁹ and collateral management services) for its U.S. Participants using equity securities issued by U.S. Issuers¹⁰ (“U.S. Equity Securities”)¹¹

⁶ As used herein, the term “U.S. Government Securities” has the same meaning as the term “eligible U.S. government securities” used in the Existing Exemption, which consists of government securities described in Section 3(a)(42) of the Exchange Act, except that it does not include any (i) foreign-targeted U.S. government or agency securities or (ii) securities issued or guaranteed by the International Bank for Reconstruction and Development (i.e., the World Bank) or any other similar international organization, and that are (i) Fedwire-eligible U.S. government securities, (ii) mortgage-backed pass through securities that are guaranteed by the Government National Mortgage Association (“GNMA”), and (iii) any collateralized mortgage obligation whose underlying securities are Fedwire-eligible U.S. government securities or GNMA guaranteed mortgage-backed pass through securities and which are depository eligible securities. For reference purposes, Fedwire is a large-value transfer system operated by the Board of Governors of the Federal Reserve System that supports the electronic transfer of funds and of book-entry securities. See Original Exemption Order, supra note 1, at 8239.

⁷ As used herein, the term “U.S. Participant” refers to any Euroclear System participant having a U.S. residence, based upon the location of its executive office or principal place of business, including, without limitation, (i) a U.S. bank (as defined by Section 3(a)(6) of the Exchange Act), (ii) a foreign branch of a U.S. bank or U.S.-registered broker-dealer, and (iii) any broker-dealer registered as such with the Commission, even if such broker-dealer does not have a U.S. residence.

⁸ See Original Exemption Order, supra note 1, at 8232.

⁹ As used herein, the term “CSD services” has the meaning set forth in 17 CFR 240.17Ad-22(a)(2). The Commission notes that it has proposed to move this definition to 17 CFR 240.17Ad-22(a)(3). See Exchange Act Release No. 34-71699 (Mar. 12, 2014), 79 FR 16865, 16970 (Mar. 26, 2014), corrected at 79 FR 29507, 29612 (May 22, 2014).

¹⁰ As used herein, the term “U.S. Issuer” refers to an issuer organized or incorporated under the laws of any state of the United States, territory thereof, or the District of Columbia.

to fulfill certain collateral obligations. Those additional clearing agency services, referred to herein as the “U.S. Equities Clearing Agency Activities,” specifically consist of the following:

(a) the provision of clearing agency services (such as certain CSD services and collateral management services) in relation to U.S. Participants’ use and reuse of U.S. Equity Securities issued by U.S. Issuers in support of collateral obligations utilizing the collateral management services provided by EB in relation to any securities or cash account held at EB that is used to receive collateral (“Collateral Accounts”)¹² in connection with the services described in (b) below and in connection with receipt and delivery from other Euroclear System participants that are users of such collateral management services provided by EB; and

(b) solely for the purpose of implementing the services described in (a) above, the provision of certain clearing agency services for U.S. Participants’ receipt and delivery of U.S. Equity Securities in relation to collateral management services through accounts held at EB that are linked to EB’s account held at DTC.¹³

EB would create the Collateral Accounts for use in the provision of the U.S. Equities Clearing Agency Activities, and for use in connection with a joint venture between Euroclear SA/NV (“ESA”), the parent company of EB, and The Depository Trust and Clearing Corporation (“DTCC”), called DTCC-Euroclear Global Collateral Ltd. (“DEGCL”). As further described

¹¹ As used herein, the term “U.S. Equity Securities” refers to an instrument that represents a direct ownership in a company, such as a stock, share, certificate of interest, or participation in any profit sharing agreement, preorganization certificate of subscription, voting trust certificate or certificate of deposit for an equity security, limited partnership interest, interest in a joint venture or certificate of interest in a business trust. However, the term “U.S. Equity Securities” does not include interests in structured finance vehicles such as limited partnerships, business trusts, or similar arrangements that have no independent operations and are used solely as special purpose financing vehicles. See Modification Application, Exhibit S-1 at 2.

¹² See Modification Application, Exhibit S-1 at 10–15. The use of the term Collateral Accounts herein includes both IMS Linked Accounts and EB’s collateral management services. For a description of the IMS Linked Accounts, see Modification Application, Exhibit S-1 at 10–11.

¹³ See Modification Application, Exhibit S-1 at 40.

herein, DEGCL would provide an inventory management service (“JV-IMS”) to facilitate, among other things, the repositioning and crediting of assets, including U.S. Equity Securities, throughout the EB infrastructure that would be used to provide the collateral management services.

EB requests that it be permitted to provide the U.S. Equities Clearing Agency Activities without registering as a clearing agency and subject to the applicable conditions specified below. In addition, EB requests that it be permitted to continue providing the U.S. Government Securities Clearing Agency Activities without registering as a clearing agency and under substantially the same conditions as those set forth in the Existing Exemption.

The Commission is publishing this notice to solicit comments from interested persons on the Modification Application. The Commission will consider any comments it receives in making its determination whether to approve the Modification Application.

II. Background

A. EB Organization and Legal Framework

EB is a limited liability company organized under the laws of Belgium and also is authorized in Belgium as a Belgian credit institution. EB is an international CSD and a global provider of clearance, settlement, collateral management, and related services. In particular, EB provides its participants with a means of acquiring, holding, transferring, and pledging security entitlements by electronic book-entry on its records outside of the United States, either free of payment or against payment, in multiple currencies.¹⁴ EB is headquartered in Brussels, Belgium,

¹⁴ See Modification Application, Exhibit S-1 at 3.

with a secondary office in Braine l'Alleund, Belgium, branch offices in Wanchai, Hong Kong and Krakow, Poland, and a representative office in New York City.¹⁵

EB is part of a group of companies that serve as market infrastructures by offering clearing agency services to the domestic markets in Belgium, Netherlands, France, England, Ireland, Sweden, and Finland (collectively with EB, the “Euroclear Group”).¹⁶ Entities in the Euroclear Group are subsidiaries of ESA, a Belgian limited liability company.¹⁷ Control and direction of the Euroclear Group strategic decisions are vested in ESA. ESA provides common services to EB and other affiliated companies of the Euroclear Group.¹⁸ ESA maintains intercompany agreements with EB that set forth respective services and obligations.¹⁹

As previously noted, all services performed by EB that relate to securities settlement and custody are part of the Euroclear System, which is designated as a securities settlement system under the Belgian Settlement Finality Act.²⁰ According to EB, Belgian law provides for robust asset protection rights for assets deposited in the Euroclear System and for the protection of the holding of assets on the books of EB.²¹ Furthermore, EB represents that Belgian law and EB’s

¹⁵ See Modification Application, Exhibit I-1.

¹⁶ In 2015, the Euroclear Group had assets under custody of €27.5 trillion, turnover equivalent to €74.7 trillion, and a settlement volume of 190.7 million netted transactions. Euroclear Group’s collateral management platform, the Collateral Highway, processed collateralized transactions in 2015 for an amount of €1.068 trillion on a daily basis. See Modification Application, Exhibit S-1 at 3.

¹⁷ See Modification Application, Exhibit A-2.

¹⁸ See Modification Application, Exhibit S-1 at 3.

¹⁹ Id.

²⁰ See Modification Application, Exhibit K-5 at 22.

²¹ See Modification Application, Exhibit S-1 at 35.

arrangements provide a high degree of certainty with regards to finality of transfers on EB's books, the holding of collateral in accounts, the contractual framework of participants in the Euroclear System, and default procedures.²²

To utilize the Euroclear System, EB participants enter into a contractual relationship with EB to open and maintain securities and cash accounts at EB.²³ EB participants agree that their rights to assets held in the Euroclear System are defined and governed by Belgian law.²⁴ EB states that under Belgian law, it is generally the beneficiary of a statutory lien on assets in accounts held at EB to secure any claim it has against EB participants arising in connection with the clearance or the settlement of transactions through, or in connection with, the Euroclear System, including claims resulting from loans or advances.²⁵

B. Regulatory Oversight of EB and ESA

EB represents that it is subject to consolidated supervision by the National Bank of Belgium ("NBB") and the Belgian Financial Services Market Authority ("FSMA").²⁶ EB also represents that NBB supervises ESA, due to its status as an authorized holding company of a

²² See Modification Application, Exhibit S-1 at 35.

²³ See Modification Application, Exhibit J.

²⁴ Specifically, EB represents that EB participants' rights in securities held in the Euroclear System are defined and governed by Belgian Royal Decree No. 62 dated Nov. 10, 1967 on the Deposit of Fungible Financial Instruments and the Settlement of Transactions involving such Instruments or similar Belgian legislation. EB states that the applicable Belgian law is effectively similar to securities entitlements under Revised Article 8 of the Uniform Commercial Code. See Modification Application, Exhibit S-1 at 36.

²⁵ See Modification Application, Exhibit E-5 at 34.

²⁶ See Modification Application, Exhibit S-1 at 19.

regulated credit institution (i.e., EB) and as an institution assimilated to a securities settlement system (i.e., the Euroclear System).²⁷

According to EB, the NBB exercises its supervision over EB and ESA on a consolidated basis.²⁸ Specifically, the NBB has prudential supervision and oversight over EB as a licensed credit institution operating in Belgium. Furthermore, the NBB supervises EB in its role as operator of the Euroclear System and as a recognized CSD. EB states that the NBB is required to ensure: (1) that EB's clearance, settlement, and payment systems operate properly; (2) that those systems are efficient and sound; and (3) that EB meets the obligations applicable to credit institutions under applicable European law, as adopted into Belgian law.²⁹ EB represents that the NBB has the authority to order EB to limit, suspend, or stop activities if EB does not comply with the regulatory requirements of its various authorizations.³⁰ EB also states that the NBB assesses EB under the *Principles for Financial Market Infrastructures* ("PFMI") and considers best practices where appropriate.³¹

²⁷ See Modification Application, Exhibit S-1 at 20. According to EB, pursuant to Article 20, § 2 of the Belgian Royal Decree of September 26, 2005, institutions assimilated to a settlement institution may not have shareholdings in commercial companies without the prior approval of the NBB, unless the shareholding is taken in companies whose activities consist, in whole or in part, in the activities which a settlement institution or an institution assimilated thereto may carry out.

²⁸ Id. In addition, EB is submitted to the Regulation 575/2013 of 26 June 2013 on prudential requirements for credit institutions and investment firms (CRR) IV and Regulation 909/2014 of 23 July 2014 on improving securities settlement in the European Union and on central securities depositories (CSDR). See Modification Application, Exhibit K-5 at 16.

²⁹ See Modification Application, Exhibit S-1 at 20.

³⁰ Id.

³¹ See Modification Application, Exhibit S-1 at 20. The PFMI are standards applicable to financial market infrastructures, such as CSDs and securities settlement systems. Committee on Payment and Settlement Systems (now the Committee on Payment and Market Infrastructure)

EB further represents that the FSMA regulates EB for the purposes of compliance with investor protection rules and rules on the operation, integrity, and transparency of the Belgian financial markets.³² These include requirements relating to conflicts of interest with clients, customer protection in case of insolvencies, and enforcement of conduct requirements.

C. EB's Existing Exemption

The Commission originally granted the Existing Exemption in 1998 to EB's predecessor, Morgan Guaranty Trust Company of New York, Brussels Office ("MGT-Brussels"), as operator of the Euroclear System (the Original Exemption Order).³³ Before EB replaced MGT-Brussels as the operator of the Euroclear System, the Commission approved a modification to the Original Exemption Order to reflect the change in control of the Euroclear System from MGT-Brussels to EB (the 2001 Exemption Modification Order).³⁴ Under the Existing Exemption, EB may only provide the U.S. Government Securities Clearing Agency Activities to U.S. Participants.³⁵

Under the terms of the Existing Exemption, the Commission placed a limit on the volume of transactions in U.S. Government Securities conducted by U.S. Participants that can be settled through the Euroclear System. Specifically, the average daily volume of U.S. Government Securities settled through the Euroclear System for U.S. Participants may not exceed five percent

and Technical Committee of the International Organization of Securities Commissions, Principles for financial market infrastructures (Apr. 16, 2012), available at <http://www.bis.org/publ/cpss101a.pdf>.

³² See Modification Application, Exhibit S-1 at 20–21.

³³ See supra note 1.

³⁴ The change in control of the Euroclear System from MGT-Brussels to EB has been the only modification of the exemption. See supra note 1. The 2001 Exemption Modification Order was the last time the Commission modified the Existing Exemption.

³⁵ See Original Exemption Order, supra note 1, at 8239.

of the total average daily dollar value of the aggregate volume in U.S. Government Securities.³⁶ To facilitate the monitoring of compliance with the volume limit and the impact of EB's operations on the U.S. Government Securities market under the Existing Exemption, EB is required to provide the Commission with quarterly reports, calculated on a twelve-month rolling basis, of (i) the average daily volume of transactions in eligible U.S. Government Securities for U.S. Participants that are subject to the volume limit and (ii) the average daily volume of transactions in eligible U.S. Government Securities for all Euroclear System participants, whether or not subject to the volume limit.³⁷

EB is also required to notify the Commission regarding material adverse changes in any account maintained in the Euroclear System for U.S. Participants.³⁸ In addition, EB is required to respond to Commission requests for information regarding any U.S. Participant about whom the Commission has financial solvency concerns, including, for example, a settlement default by a U.S. Participant.³⁹ The Commission also required the execution of a satisfactory memorandum

³⁶ See id. at 8239.

³⁷ See Original Exemption Order, supra note 1, at 8240. EB's non-U.S. participants are not subject to any restrictions under the Existing Exemption.

³⁸ For purposes of the Original Exemption Order, the term "material adverse changes" included (i) the termination of any U.S. Participant; (ii) the liquidation of any securities collateral pledged by a U.S. Participant to secure an extension of credit made through the Euroclear System; (iii) the institution of any proceedings to have a U.S. Participant declared insolvent or bankrupt; or (iv) the disruption or failure in whole or in part in the operations of the Euroclear System either at its regular operating location or at its contingency center. See Original Exemption Order, supra note 1, at 8240, n.78.

³⁹ See Original Exemption Order, supra note 1, at 8240.

of understanding with the Belgian banking and securities regulator (currently the NBB) to facilitate the provision of information by EB to the Commission.⁴⁰

D. EB Collateral Management Services

EB participants are able to utilize various clearance and settlement services through the Euroclear System.⁴¹ Among those services are the EB collateral management services (“EB-CMS”), which provide a framework for exchanging collateral to fulfill bilateral obligations between counterparties.⁴² Parties to bilateral arrangements that require the posting of collateral by one party (“Collateral Giver”) in favor of the other party (“Collateral Taker”) may use the EB-CMS to secure credit exposures arising under such bilateral arrangements. The terms of such bilateral arrangements and related collateral needs (including the credit exposure, collateral requirements, and collateral terms) are negotiated and agreed between the parties independently of EB. After such arrangements are agreed, the parties then enter into an agreement with EB to provide the collateral management services.

EB states that its non-U.S. participants use the EB-CMS to meet collateral obligations with a variety of assets, including U.S. Government Securities and U.S. Equity Securities.⁴³ EB also represents that U.S. Participants currently use the EB-CMS to meet collateral obligations with a wide variety of assets including U.S. Government Securities but not U.S. Equity

⁴⁰ See 2001 Exemption Modification Order, supra note 1, at 821; see also Understanding Regarding an Application of Euroclear Bank for an Exemption Under U.S. Federal Securities Laws (January, 30, 2001) available at https://www.nbb.be/doc/cp/nl/aboutcbfa/mou/pdf/mou_2001-01-30_euroclearbank.pdf.

⁴¹ See Modification Application, Ex. J.

⁴² See Modification Application, Ex. S-1 at 3.

⁴³ See Modification Application, Exhibit S-1 at 34.

Securities,⁴⁴ as the Existing Exemption prohibits EB from allowing U.S. Participants to hold U.S. Equity Securities in an account held at EB for any purpose. EB states that as part of its contractual documentation with its participants, it prohibits any U.S. Participant from holding U.S. Equity Securities in accounts held at EB for any purpose (“Current Equities Restrictions”).⁴⁵ EB represents that automated systems protocols and control procedures are implemented in the Euroclear System to enforce the Current Equities Restrictions. The systems protocols consist of coded validation rules that are part of EB’s fully automated and standard processes that run prior to the settlement of any securities movement to or from an account held at EB.⁴⁶

III. EB’s Proposed Infrastructure

As introduced earlier and discussed further below, EB has requested that the Commission broaden the Existing Exemption to allow it to provide collateral management services to its U.S. Participants using U.S. Equity Securities. Under the Existing Exemption, EB may already offer the EB-CMS for U.S. Government Securities to both U.S. Participants and non-U.S. participants, but EB may only offer the EB-CMS for U.S. Equity Securities to its non-U.S. participants. EB has made the request to broaden its exempt clearing agency activities for the purpose of assisting its participants’ compliance with new regulations described below scheduled to take effect in the near future that will significantly affect the use of collateral. In connection with its request, EB

⁴⁴ Id.

⁴⁵ EB’s customer contracts provide that: “Due to restrictions imposed on Euroclear Bank by the United States Securities and Exchange Commission (S.E.C.) following SEC Rule 17Ab2-1, equities, ETFs and REITs issued by companies incorporated in a state or territory of the United States can be held in Euroclear Bank by non-US Participants only.” See Modification Application, Exhibit S-1 at 6.

⁴⁶ Id.

is taking preparatory measures to create the infrastructure to accommodate the U.S. Equities Clearing Agency Activities. For example, as further described below, DEGCL was formed in part to facilitate a U.S. Participant's repositioning of assets in the U.S. Participant's account held at The Depository Trust Company ("DTC") to create a credit for those assets in the U.S. Participant's Collateral Account held at EB for use in the EB-CMS.

A. New Collateral Regulations

According to the Modification Application, new and enhanced regulatory requirements ("New Collateral Regulations") are leading counterparties to derivative and financing transactions to seek streamlined margin processing and increased efficiency in the availability and deployment of collateral.⁴⁷ These New Collateral Regulations are expected to be implemented in the European Union in the near future.⁴⁸ EB states that the regulatory changes include new restrictions on eligible collateral, requiring the use of highly liquid assets, prescribed haircuts, and segregation requirements, as well as a prohibition on rehypothecation for initial margin. EB believes that when fully implemented, the New Collateral Regulations will result in increased capital requirements, mandatory central clearing of more derivative transactions, and new margining rules for bilateral trades, which will increase demand for high quality collateral. EB projects that the requirement for more transactions and exposures to be collateralized globally will result in a significant increase in the number of required collateral movements

⁴⁷ See Modification Application, Exhibit S-1 at 6.

⁴⁸ Id.; see also letter from Gabriel Bernardino, Chair of the Joint Committee of the European Supervisory Authorities to Lord Jonathan Hill, EU Commissioner for Financial Stability, Financial Services and Capital Markets Union European Commission (June 30, 2016) (regarding the delayed adoption of the Joint draft Regulatory Technical Standards on risk mitigation techniques for non-centrally cleared OTC derivatives), available at https://eiopa.europa.eu/Publications/Joint%20Committee/ESAs%202016%2050%20%28ESAs_joint_letter%20to%20the%20Commission%20on%20delayed%20adoption.pdf.

between market participants, which will have implications for counterparty credit risk, funding and capital charges, and reputational and operational risk.

EB also represents that these regulatory changes include requirements for initial margin for counterparties to certain derivative and financing transactions, as well as a reduction or removal of unsecured thresholds for variation margin. EB expects that these new initial margin requirements will significantly increase the amount of collateral required to support a number of derivative and financing transactions. In addition, EB represents that it is expected that the removal or reduction of unsecured thresholds for variation margin will mean any changes in underlying transaction valuations may trigger increased margin calls, requiring market participants to hold additional collateral available for posting.

EB represents that the New Collateral Regulations therefore are expected to greatly increase the complexity of collateral management and create new competition for collateral.⁴⁹ Industry research cited by EB indicates that as these regulatory changes take effect, the volume of required collateral movements will increase and the number of collateral settlement fails and associated costs are likely to rise proportionally.⁵⁰

⁴⁹ EB states that collateral movements will need to be tracked and applied against a growing number and type of credit support documentation, while segregation rules will multiply the number of collateral accounts needed and correspondingly increase the complexity of accurately processing collateral movements across account types, fragmented central clearing and collateral delivery channels. See Modification Application, Exhibit S-1 at 7; see also Implications of Collateral Settlement Fails: An Industry Perspective on Bilateral OTC Derivatives (Feb. 2016), available at http://www.imas.org.sg/uploads/media/2016/03/03/1046_Implications_of_Collateral_Settlement_Fails_FINAL.pdf (“Implications of Collateral Settlement Fails”); Collateral Management in Europe: Searching for Central Intelligence (May 2015), available at <https://www.euroclear.com/dam/Brochures/Euroclear-Collateral-Management-Aite-Paper.pdf>; The Economics of Collateral (Dec. 2013), available at <http://dtcc.com/~media/Files/Downloads/WhitePapers/LSE%20Report.ashx>.

⁵⁰ See, e.g., Implications of Collateral Settlement Fails, supra note 49, at 5.

B. DEGCL

DEGCL was formed to help market participants comply with the New Collateral Regulations, and will offer global information, recordkeeping, and processing services for derivatives collateral movements and other types of financing transactions.⁵¹ ESA and DTCC formed the joint venture in 2014, and DEGCL is authorized as a service company by the Financial Conduct Authority (“FCA”) in the United Kingdom.⁵² EB represents that DEGCL seeks to provide services to its users, including buy-side and sell-side financial institutions, in meeting their risk management and regulatory requirements for the holding and exchange of collateral as required by the New Collateral Regulations.⁵³ These services will be offered to users located primarily in Europe and the U.S.⁵⁴ In particular, DEGCL would provide the JV-IMS to help facilitate the U.S. Equities Clearing Agency Activities.⁵⁵

1. DEGCL JV-IMS

EB represents that the JV-IMS would provide an automated mechanism for an entity that is both a participant of EB and DTC (“JV-IMS User”)⁵⁶ to receive recommendations on how to reposition assets in the JV-IMS User’s account held at DTC, including U.S. Equity Securities, for subsequent crediting of those assets to its Collateral Accounts within the EB-CMS (and for

⁵¹ See Modification Application, Exhibit S-1 at 3.

⁵² DEGCL’s reference number as an authorized service company is 686269. See FCA Financial Services Register, available at <https://www.fca.org.uk/register>.

⁵³ See Modification Application, Exhibit S-1 at 7.

⁵⁴ See id.

⁵⁵ See Modification Application, Exhibit S-1 at 8.

⁵⁶ See id.

the return of such assets to the JV-IMS User's account held at DTC). To facilitate the JV-IMS, EB will become a participant at DTC, subject to approval by DTC, its standard membership requirements and certain heightened requirements for a non-U.S. entity.⁵⁷

Prior to initial use, a JV-IMS User will set parameters that specify which types of assets in its account held at DTC (and in what amounts) it will make available for the JV-IMS, including any limits or criteria on those assets (such as ratings).⁵⁸ The JV-IMS User will then transfer assets that meet the parameters to a sub-account held at DTC that is designated for, and dedicated to, the JV-IMS. (See Step 1 of Chart 1 below.) The JV-IMS will then monitor that information and independently verify that the assets identified by the JV-IMS User meet its own parameters, as well as the EB eligibility requirements (such as an accepted CUSIP number). If so, the JV-IMS will prepare and submit to EB free of payment delivery instructions (which EB will in turn submit to DTC on the JV-IMS User's behalf) to transfer the assets identified by the JV-IMS User in its designated sub-account held at DTC to EB's account held at DTC.⁵⁹ (See Step 2 of Chart 1 below.) The JV-IMS will also prepare and submit instructions to EB to credit such transferred assets from EB's account held at DTC to the relevant JV-IMS User's Collateral Accounts. (See Step 2a of Chart 1 below.)

⁵⁷ EB has signed a DTC Participant's Agreement pursuant to which it agreed that the DTC rules shall be a part of the terms and conditions of every contract or transaction that EB may make or have with DTC. See id.; see also DTC Policy Statements on the Admission of Participants (June 2013).

⁵⁸ See Modification Application, Exhibit S-1 at 8.

⁵⁹ This process is subject to DTC rules governing EB's role in repositioning assets. See Self-Regulatory Organizations; The Depository Trust Company; Order Approving Proposed Rule Change to Establish a Link with Euroclear, Exchange Act Release No. 78358 (July 19, 2016), 81 FR 48482 (July 25, 2016) (DTC-2016-004) ("DTC EB Link Rule").

Additionally, the JV-IMS would facilitate the automated return of such assets to the JV-IMS User's account held at DTC when necessary to meet other settlement obligations and for corporate actions by preparing and submitting to EB (for eventual forwarding by EB to DTC) free of payment delivery instructions to transfer such assets from EB's account held at DTC to the relevant JV-IMS User's sub-account held at DTC. Finally, the JV-IMS would report to the JV-IMS User all settlement instructions generated via the JV-IMS, the status of the generated settlement instructions, and other relevant information in regards to such settlement instructions. All of the foregoing would be subject to the DTC rules regarding a link with EB that was approved by the Commission in July 2016.⁶⁰

C. EB Collateral Accounts

After the JV-IMS User's assets are credited to EB's account held at DTC via the JV-IMS processes described above, the assets would then be credited to the Collateral Accounts for the relevant EB participant.⁶¹ As stated above, EB's internal protocols would structure these Collateral Accounts to only allow U.S. Participants: (1) to take receipt of U.S. Equity Securities credited to the account via the JV-IMS process described immediately above; (2) to deliver U.S. Equity Securities out of the Collateral Accounts for mobilization as collateral through the EB-CMS infrastructure and to receive U.S. Equity Securities into the Collateral Accounts mobilized from other participants of the EB-CMS; and (3) to deliver U.S. Equity Securities back to the relevant JV-IMS User's sub-account at DTC. (See Step 3 of Chart 1 below.) EB represents that

⁶⁰ See id.

⁶¹ All settlement activity related to the JV-IMS that occurs on the books of DTC is governed exclusively by DTC procedures. All activity related to the use of assets that occurs on the books of EB is governed exclusively by the EB contractual framework. See Modification Application, Exhibit S-1 at 9.

these transfer and use restrictions on Collateral Accounts would prevent a U.S. Participant's U.S. Equity Securities held in Collateral Accounts from being used for any other purposes in the Euroclear System, such as normal settlement activity, except under certain circumstances involving the default of a Collateral Giver.⁶²

Currently, non-U.S. JV-IMS Users may move U.S. Equity Securities from DTC to EB by transferring the securities to an account held at DTC for EB's custodian. If the Modification Application is approved, non-U.S. JV-IMS Users may transfer U.S. Equity Securities to either EB's account held at DTC or an account held at DTC for EB's custodian.

If a JV-IMS User defaults, either a Collateral Taker or a Collateral Giver can notify EB of a default under their bilateral transaction. EB's operations staff would then initiate a process to override the regular controls that govern use of U.S. Equity Securities as collateral and instead would instruct DTC to debit those securities from EB's DTC Account and to credit them to the account held at DTC for EB's custodian, while still being credited to the Collateral Taker's account at EB.⁶³

In the Modification Application, EB proposes to amend the Current Equities Restrictions⁶⁴ to permit the use by U.S. Participants of U.S. Equity Securities subject to the transfer and use restrictions described above. In all other circumstances, the Current Equities Restrictions would otherwise remain applicable.

⁶² See Modification Application, Exhibit S-1 at 11.

⁶³ Id.

⁶⁴ See supra Section II.D.

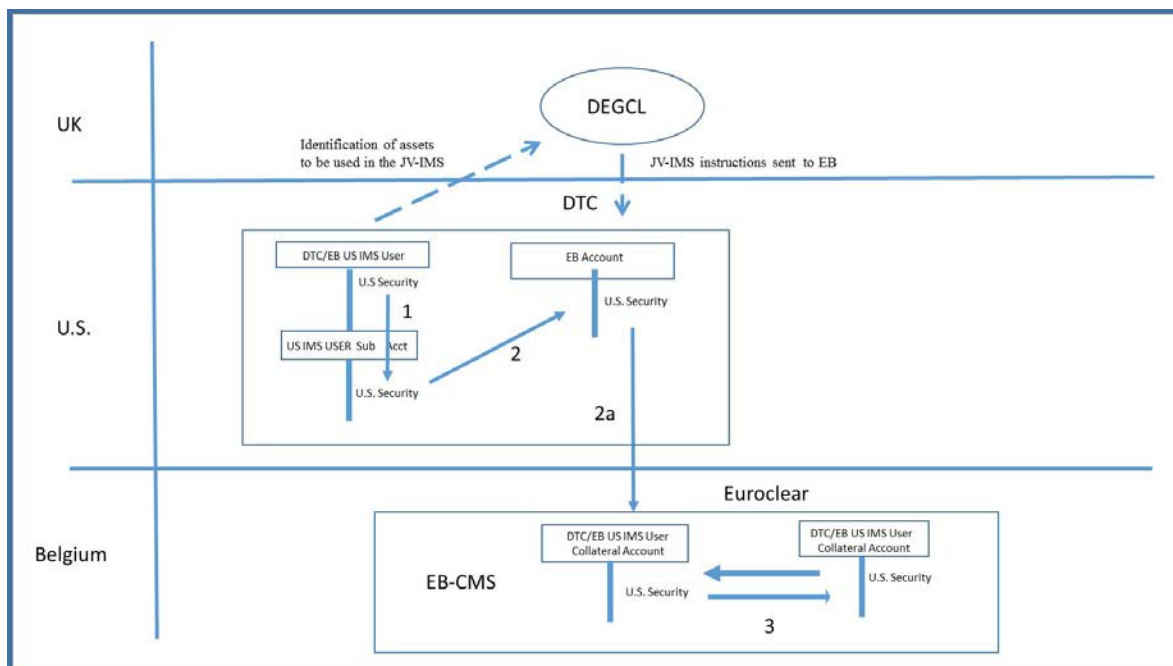

Chart 1

IV. The Modification Application

The Modification Application requests that the Commission do the following: (i) continue the Existing Exemption under substantially similar conditions except as otherwise specified herein, (ii) broaden the Existing Exemption to allow EB to provide the U.S. Equities Clearing Agency Activities under new conditions applicable to those activities, and (iii) apply conditions to EB that are largely harmonized between the U.S. Government Securities Clearing Agency Activities and U.S. Equity Clearing Agency Activities (collectively, the “Clearing Agency Activities”).

A. Continue the Existing Exemption on Substantially Similar Conditions Specific to U.S. Government Securities Clearing Agency Activities

EB specifically requests that the Commission continue the Existing Exemption to conduct the U.S. Government Securities Clearing Agency Activities without: (i) requiring EB to register as a clearing agency with the Commission; (ii) changing the definition of the terms U.S.

Government Securities or U.S. Participants, as set forth in the Existing Exemption; or (iii) changing the conditions set forth in the Existing Exemption with regards to the U.S. Government Securities Clearing Agency Activities, listed below:

(a) Volume Limit. The average daily volume of transactions in eligible U.S. Government Securities for U.S. Participants processed through EB as operator of the Euroclear System may not exceed five percent of the total average daily dollar value of the aggregate volume in eligible U.S. Government Securities.

(b) Commission Access to Information regarding U.S. Government Securities Clearing Agency Activities. EB will continue to provide the Commission with quarterly reports, calculated on a twelve-month rolling basis, of (a) the average daily volume of transactions in eligible U.S. Government Securities for U.S. Participants that are subject to the volume limit as described in Section IV.C.2 of the Original Exemption Order and (b) the average daily volume of transactions in eligible government securities for all Euroclear System participants, whether or not subject to the volume limit as described in Section IV.C.2 of the Original Exemption Order.⁶⁵

EB also requests that the following conditions of the Existing Exemption with regards to the U.S. Government Securities Clearing Agency Activities be replaced and superseded by the corresponding conditions set forth in Part VI.D. below that are applicable to the Clearing Agency Activities:

(a) the obligations in Section IV.C.3 of the Original Exemption Order to provide disclosure documents to the Commission;

(b) the obligations in Section IV.C.3 of the Original Exemption Order to file with the Commission amendments to its application for exemption on Form CA-1; and

(c) the obligations in Section IV.C.3 of the Original Exemption Order to notify the Commission regarding material adverse changes in any account maintained by Euroclear for its U.S. Participants and to respond to a Commission request for

⁶⁵ See Modification Application, Exhibit S-1 at 39.

information about any U.S. Participant about whom the Commission has financial solvency concerns.⁶⁶

B. Modify the Existing Exemption to Permit EB to Perform U.S. Equities Clearing Agency Activities Subject to Additional Conditions

EB requests that the Commission permit EB to provide, without registering as a clearing agency with the Commission, the U.S. Equities Clearing Agency Activities. As described in the Modification Application, EB's provision of U.S. Equities Clearing Agency Activities would entail activities such as custody and safekeeping,⁶⁷ settlement,⁶⁸ and asset servicing⁶⁹ on behalf of U.S. Participants with respect to U.S. Equity Securities. For example, EB would maintain securities accounts on its books,⁷⁰ provide safekeeping of and recordkeeping for those securities accounts,⁷¹ settle instructions by participants,⁷² and provide recordkeeping and reporting in real time on the status of settlement to participants.⁷³ EB would also process corporate actions as part of its asset servicing business for any U.S. Equity Securities that remain in EB's account held at DTC on the record date.⁷⁴

⁶⁶ See id.

⁶⁷ See Modification Application, Exhibit S-1 at 4.

⁶⁸ See Modification Application, Exhibit S-1 at 5.

⁶⁹ See Modification Application, Exhibit S-1 at J-3.

⁷⁰ See Modification Application, Exhibit S-1 at 2.

⁷¹ See Modification Application, Exhibit K-5 at 80–81.

⁷² See Modification Application, Exhibit K-5 at 76, 83.

⁷³ See Modification Application, Exhibit K-5 at 76.

⁷⁴ See Modification Application, Exhibit J-3.

The EB-CMS would be offered to U.S. Participants in support of their obligations under security-based swap transactions, securities lending transactions, and repurchase agreements, among other transactions.⁷⁵ The EB-CMS would independently verify that the collateral proposed and provided by the Collateral Giver meets the terms reported by the counterparties for the duration of the collateral obligation.⁷⁶ EB would do this by calculating the exchange of value necessary to meet the collateral obligation information entered in by the users of the EB-CMS, including by making value determinations, such as marking to market the value of the collateral based on reference data.⁷⁷ Also, EB would generate instructions and communicate the instructions to EB’s settlement processing infrastructure to transfer collateral among the Collateral Accounts.⁷⁸

V. Applicable Statutory Standards

A. Section 17A of the Exchange Act

Section 17A of the Exchange Act directs the Commission to facilitate the establishment of (i) a national system for the prompt and accurate clearance and settlement of securities

⁷⁵ See, e.g., Modification Application, Exhibit P-2 (describing necessary revisions to its Operating Procedures related to collateral services, derivatives services, loan services, repurchase services, and securities lending services arising out of the proposed U.S. Equities Clearing Agency Activities).

⁷⁶ See Modification Application, Exhibit J-3.

⁷⁷ See Modification Application, Exhibit K-5 at 60 (referencing obtaining the market value of a security. The EB-CMS system does not apply any further haircuts or adjustments once the market value is obtained from third party data providers); see also Euroclear plc, Risk Management at Euroclear: Including Pillar 3 Disclosure 2012 – Euroclear plc, at 43 (2012) (“Securities for which Euroclear Bank does not obtain external quotations regularly can also be valued according to the price associated with securities transactions in the Euroclear system, or according to theoretical models.”), available at https://www.euroclear.com/dam/Brochures/Pillar3_2012.pdf.

⁷⁸ See Modification Application, Exhibit J-3.

transactions and (ii) linked or coordinated facilities for clearance and settlement of securities transactions.⁷⁹ In facilitating the establishment of the national clearance and settlement system, the Commission must have due regard for the public interest, the protection of investors, the safeguarding of securities and funds, and maintenance of fair competition among brokers and dealers, clearing agencies, and transfer agents.⁸⁰ Section 17A(b)(1) of the Exchange Act requires all clearing agencies to register with the Commission.⁸¹ It also states that, upon the Commission's motion or upon a clearing agency's application, the Commission may conditionally or unconditionally exempt a clearing agency from any provision of Section 17A of the Exchange Act or the rules or regulations thereunder if the Commission finds that such exemption is consistent with the public interest, the protection of investors, and the purposes of Section 17A of the Exchange Act, including the prompt and accurate clearance and settlement of securities and funds.

The Commission notes that the proposed Clearing Agency Activities would be the only clearing agency activities EB would perform under an exemption order.⁸² For example, EB proposes to continue the U.S. Government Securities Clearing Agency Activities on substantially the same basis as under the Existing Exemption. For the purposes of the U.S. Equities Clearing Agency Activities, EB is not proposing to act as a CSD for the issuance of new U.S. Equity

⁷⁹ See 15 U.S.C. 78q-1(a)(2); see also Report of the Senate Committee on Banking, Housing & Urban Affairs, S. Rep. No. 94-75, at 4 (1975) (stating that “[t]he Committee believes the banking and security industries must move quickly toward the establishment of a fully integrated national system for the prompt and accurate processing and settlement of securities transactions”).

⁸⁰ See 15 U.S.C. 78q-1(a)(2)(A).

⁸¹ See 15 U.S.C. 78q-1(b) and 17 CFR 240.17Ab2-1.

⁸² See 15 U.S.C. 78c(a)(23). For example, EB will not act as a central counterparty.

Securities, nor is it seeking to facilitate the settlement of purchase and sale transactions in U.S. Equity Securities; its limited role would be to facilitate use by U.S. Participants of U.S. Equity Securities via the EB-CMS. EB also is not proposing to operate as a self-regulatory organization similar to registered clearing agencies or perform other clearing agency functions such as acting as a central counterparty, netting transactions or comparing trade execution information.

The Commission notes that it has previously found an exemption from clearing agency registration to be an appropriate response in instances where an entity has engaged in a limited scope of clearing agency activity. For example, the Commission has previously concluded that entities providing only matching services could obtain an exemption from registration as a clearing agency.⁸³ Additionally, and similar to the approach taken under the Existing Exemption for EB, the Commission has also previously granted an exemption from registration as a clearing agency to another entity that was performing clearance, settlement, and collateral management services for certain U.S. government securities.⁸⁴

When the Commission approved the Original Exemption Order and the 2001 Exemption Modification Order, it stated that granting either exemptions from portions of Section 17A of the Exchange Act or from registration requires substantial compliance with Section 17A of the Exchange Act and the rules and regulations thereunder based on a review of the standards in

⁸³ See, e.g., Interpretation: Confirmation and Affirmation of Securities Trades; Matching, Exchange Act Release No. 39829 (Apr. 6, 1998), 63 FR 17943 (Apr. 13, 1998); Bloomberg STP LLC; SS&C Technologies, Inc.; Order of the Commission Approving Applications for an Exemption From Registration as a Clearing Agency; Notice, Exchange Act Release No. 34-76514 (Nov. 24, 2015), 80 FR 75388 (Dec. 1, 2015).

⁸⁴ See, e.g., Self-Regulatory Organizations; Cedel Bank; Order Approving Application for Exemption From Registration as a Clearing Agency, Exchange Act Release No. 38328 (Feb. 24, 1997), 62 FR 9225 (Feb. 28, 1997).

place.⁸⁵ The Existing Exemption therefore reflected an approach whereby certain determinations were made regarding the then-current rules and structure of EB, as identified in Section 17A(b)(3)(A) through (I) of the Exchange Act. In the Modification Application, EB has represented that it continues to meet the standards previously applied when the Commission approved the Existing Exemption⁸⁶ and, for the purposes of its consideration of the Modification Application, the Commission is taking those representations into account.⁸⁷ In light of its experience with EB under the Existing Exemption since 1998, as well as its past practice of otherwise exempting from registration certain clearing agencies that perform a limited range of clearing agency services, the Commission preliminarily believes that granting EB an exemption from registration for the Clearing Agency Activities would be appropriate. Therefore, in evaluating the Modification Application, the Commission considers whether exempting EB from clearing agency registration to perform the Clearing Agency Activities satisfies the requirements of an exemption from registration under Section 17A(b)(1) of the Exchange Act, which is consistency with the public interest, the protection of investors and the purposes of Section 17A of the Exchange Act, including the prompt and accurate clearance and settlement of securities and funds.

B. Consistency of the Modification Application with Section 17A of the Exchange Act

The objectives and findings described in Section 17A of the Exchange Act include

⁸⁵ See Original Exemption Order, *supra* note 1, at 8235; 2001 Exemption Modification Order, *supra* note 1, at 820.

⁸⁶ See Modification Application, Exhibit S-1 at 13.

⁸⁷ The Commission also notes that it has no basis to believe that EB has not operated within and otherwise performed in accordance with the terms and conditions of the Existing Exemption.

developing uniform standards and procedures for clearance and settlement, employing new data processing and communication techniques that promote more efficient, effective, and safe clearance and settlement of securities transactions, and reducing the physical movement of securities in the control of a clearing agency or for which a clearing agency has custody. The findings in Section 17A of the Exchange Act also state that the implementation of linked systems and uniform standards would reduce unnecessary costs and increase the protection of investors and persons facilitating transactions by and acting on behalf of investors.

1. Facilitating the Establishment of Linked or Coordinated Facilities for the Settlement of Transactions

In adopting Section 17A of the Exchange Act, Congress found that the linking of settlement facilities and the development of uniform standards and procedures for settlement will reduce unnecessary costs and increase the protection of investors,⁸⁸ and directed the Commission to use its authority to facilitate the establishment of linked or coordinated facilities for settlement of transactions in securities.⁸⁹ The Commission preliminarily believes that the Modification Application would facilitate the establishment of linked or coordinated facilities for the settlement of securities transactions because, as previously described, the U.S. Equities Clearing Agency Activities are effectuated via the linking of settlement facilities between DTC, a registered clearing agency, and EB, a clearing agency currently exempt from registration. The Commission also preliminarily believes that the linking and coordination of these two settlement facilities will establish uniform standards and procedures that will enable entities that are

⁸⁸ See 15 U.S.C. 78q-1(a)(1)(D).

⁸⁹ See 15 U.S.C. 78q-1(a)(2)(A)(ii).

members of both DTC and EB to position U.S. securities in Europe for use as collateral in a manner that will reduce unnecessary costs and increase the protection of investors.

EB states that, in providing the U.S. Equities Clearing Agency Activities, they are in a unique position as a “neutral, inter-operable, venue-agnostic utility” to source and mobilize collateral across geographical borders and time zones.⁹⁰ According to EB, this efficiency would extend to EB’s role in both delivering and holding collateral, each of which would otherwise require fragmented, bespoke arrangements among U.S. Participants and their counterparties if conducted on a bilateral basis. The Commission preliminarily believes that the Modification Application could generate certain new efficiencies, such as those that come from using a common platform among multiple participants that can enter into a central, standardized service relationship with EB, rather than entering into multiple relationships with various trading counterparties.⁹¹ This transition to a uniform, unitary set of collateral management procedures through the EB-CMS would also allow U.S. Participants to mobilize a wider range of assets in support of fulfilling the collateral obligations underlying a variety of securities transactions, such as security-based swap transactions. The Commission therefore preliminarily believes that the U.S. Equities Clearing Agency Activities would be consistent with the efficiency objectives of Section 17A of the Exchange Act because they could potentially lead to a lower risk of

⁹⁰ See Modification Application, Exhibit K-5 at 7.

⁹¹ See generally Rodney Garratt & Peter Zimmerman, Does Central Clearing Reduce Counterparty Risk in Realistic Financial Networks?, Federal Reserve Bank of New York Staff Report No. 717 (Mar. 2015), available at https://www.newyorkfed.org/medialibrary/media/research/staff_reports/sr717.pdf (discussing core-periphery networks, and the related assumptions that links to core nodes are desirable, while links to peripheral nodes are not, because agents may prefer to deal with larger players who they are more likely to have existing relationships with; exposures to larger players may be easier to monitor; and economies of scale may mean that these larger players offer more attractive trading terms).

operational errors that could in turn minimize delivery failures by U.S. Participants (i.e., a failure of a Collateral Giver to deliver or return the required amount and type of collateral to the Collateral Taker on time and in the correct location) by using a uniform, unitary set of collateral management procedures.⁹² The Commission also believes that fewer operational errors would help U.S. Participants maintain accurate records, which could help protect investors. The Commission preliminarily believes that these enhancements to collateral delivery mechanisms also could lower the cost of U.S. Participants to manage collateral in support of their transactions with counterparties that are also EB participants.

The Commission notes that, as an alternative to the linked and coordinated approach reflected in the Modification Application, U.S. Participants could instead decide to effectuate settlement and collateral management of certain securities transactions by using the services of various market intermediaries, such as custodians, as well as relying upon internal collateral management and back office functions. The Commission preliminarily believes that the Modification Application could reduce fragmentation of contractual and operational relationships that U.S. Participants must maintain across multiple entities by instead channeling such activity into the standardized procedural framework of the linked and coordinated services provided by DTC and EB through the JV-IMS and the EB-CMS. The Commission also notes that, notwithstanding a U.S. Participant's potential use of the JV-IMS and the EB-CMS, the U.S. Equity Securities would remain immobilized at DTC, and subject to the protections applicable to DTC as a registered clearing agency, such as DTC risk management controls, including its Collateral Monitor and Net Debit Cap.⁹³ Accordingly, the Commission preliminarily believes

⁹² See Modification Application, Exhibit S-1 at 16–17.

⁹³ See DTC EB Link Rule, supra note 59.

that the Modification Application is consistent with the requirements of linked or coordinated facilities, in that it could reduce costs to U.S. Participants and increase the protection of investors and persons facilitating transactions by and acting on behalf of investors.

Finally, as discussed below, the Modification Application includes specific reporting conditions on the aggregate movements of U.S. Equity Securities into and out of the EB-CMS, which would not be available in an easily obtainable format if arrangements were conducted on a fragmented bilateral basis, which the Commission preliminarily believes will maximize transparency into these exempted clearing agency activities. The Commission preliminarily believes that the potential for linking and standardizing certain clearing agency services contemplated by the Modification Application could, in addition to yielding risk and operational efficiencies for U.S. Participants, also afford the Commission the ability, through the reporting conditions described below, to observe and more closely monitor clearing agency activity in these areas in a manner that is relatively more efficient than instances where the Commission only has fragmented visibility into a series of bilateral transactions across a series of intermediaries. As the Commission has stated previously, the ability to see the collective activity of various market participants increases transparency by providing information to regulators.⁹⁴

2. Safeguarding Securities and Funds Related to the Settlement of Securities Transactions

Congress also found that the safeguarding of securities and funds related to the settlement of securities transactions is necessary for the protection of investors,⁹⁵ and directed the

⁹⁴ See, e.g., Standards for Covered Clearing Agencies, Exchange Act Release No. 71699 (Mar. 12, 2014), 79 FR 29508, 29511 (May 22, 2014) (discussing such benefits of intermediation as increases in transparency by making information on market activity and exposures—both prices and quantities—available to regulators and the public).

⁹⁵ See 15 U.S.C. 78q-1(a)(1)(A).

Commission to have due regard for the safeguarding of securities and funds in the use of its authority under Section 17A of the Exchange Act.⁹⁶ EB represents that it has appropriate rules, procedures and controls to safeguard the rights of the securities issuers and holders and prevent unauthorized creation or deletion of securities.⁹⁷ According to EB, the creation of securities positions is only performed upon receipt of securities to be credited to client accounts. Removal of these securities positions is generally performed upon final maturity or in the context of a corporate event (e.g., an exchange). Both creation and deletion are generally processed without manual intervention at EB upon client instruction and depository confirmation. Movements in client accounts are reported on a daily basis to clients.⁹⁸

EB represents that these procedures and controls are regularly reviewed by EB's internal audit department and by its external auditor. The results of this review are made available to clients and authorities via the yearly ISAE (International Standard on Assurance Engagements) 3402 report, which would be provided to the Commission under the proposed condition in Part IV.C7.⁹⁹ In addition, each year, the external auditor reports its findings on EB's internal controls regarding the safekeeping of clients' assets to the Belgian authorities.¹⁰⁰ As previously mentioned, EB is supervised by the NBB, as well as under the investor protection mandate of the Belgian FSMA.

⁹⁶ See 15 U.S.C. 78q-1(a)(2)(A).

⁹⁷ See Modification Application, Exhibit K-5 at 80.

⁹⁸ See Modification Application, Exhibit K-5 at 81.

⁹⁹ Id.

¹⁰⁰ Id.

According to EB, it operates under the Euroclear Group's enterprise risk management framework, which includes several features, such as: (i) risk tolerance levels defined annually by the board of directors of EB, consistent with available capital, and risk tolerance levels set by the management annually with the objective to keep the risk profile low and stable; (ii) implementation of an internal capital adequacy assessment process, expressed in capital requirements over a one-year horizon and an analysis of the potential capital requirements over a five-year time horizon; (iii) comprehensive policies that set out how the internal control system supports repeatability of results; (iv) an active risk register, high-level control objectives and more detailed control objectives to identify, track and mitigate risks; (v) responsibility for risk control at all levels that is clearly assigned, including strong escalation and crises procedures that are regularly tested; (vi) risk management and audit functions that are separate and independent and report directly to the Euroclear Group CEO; (vii) review of quarterly audit and risk reports by the EB and ESA management committees and boards of directors (including the audit committees); and (viii) risk management controls that identify and address six distinct categories of risk (credit risk, liquidity risk, operational risk, market risk, business risk and strategic risk).¹⁰¹ EB also notes that the U.S. Equity Securities that would be available within the EB-CMS would be transferred only by book-entry on the books of EB and would remain deposited at DTC (either directly or indirectly).¹⁰²

The Commission has previously codified its guidance on safeguarding of funds and securities, requiring registered clearing agencies to develop and maintain plans to assure the safeguarding of securities and funds, the integrity of the automated data processing systems, the

¹⁰¹ See Modification Application, Exhibit S-1 at 26–27.

¹⁰² See Modification Application, Exhibit S-1 at 37.

recovery of securities, funds, or data under a variety of loss or destruction scenarios, and finally to have business continuity plans that allow for timely recovery of operations and ensure the fulfillment of a registered clearing agency's obligations.¹⁰³ The Commission also has previously stated its belief that the immobilization and dematerialization of securities and their transfer by book entry results in reduced costs and risks associated with securities settlements and custody by removing the need to hold and transfer many, if not most, physical certificates.¹⁰⁴ The Commission preliminarily believes that the Modification Application is consistent with these expressed goals because transfers will take place via book entry at EB. Accordingly, the Commission preliminarily believes that EB has the ability to safeguard funds and securities consistent with the requirements of the Exchange Act.

3. Prompt and Accurate Settlement of Securities Transactions

As noted above, Congress found that the prompt and accurate clearance and settlement of securities transactions is necessary for the protection of investors,¹⁰⁵ and that inefficient procedures for settlement imposed unnecessary costs on investors.¹⁰⁶ EB states that the Euroclear System is a Model 1 delivery vs. payment ("DVP") system, which means instructions are settled between clients on a trade by trade (gross) basis, with finality of the transfer of securities from the seller to the buyer occurring at the same time as the finality of transfer of funds from the buyer to the seller.¹⁰⁷ EB also states that the Euroclear System controls the

¹⁰³ See 12 CFR 240.17Ad-22(d)(4).

¹⁰⁴ Id. at 66253.

¹⁰⁵ See 15 U.S.C. 78q-1(a)(1)(A).

¹⁰⁶ See 15 U.S.C. 78q-1(a)(1)(B).

¹⁰⁷ See Modification Application, Exhibit K-5 at 7.

availability of the cash and securities before executing instructions (i.e., positioning), so that if the cash and/or the securities are not available, the technical and contractual frameworks would not allow the transaction to be settled.¹⁰⁸ EB offers real-time settlement from around 01:30 to 19:00 Brussels time to cover multiple time zones.¹⁰⁹

The Commission preliminarily believes that approval of the Modification Application would promote the prompt and accurate clearance and settlement of securities transactions and the protection of investors because EB's settlement process is consistent with prior Commission observations regarding DVP systems. In particular, the Commission has previously stated that DVP reduces the risk that a party would lose some or its entire principal because payment is made only if securities are delivered.¹¹⁰ The Commission also believes that a DVP method reduces the potential that delivery of the security is not appropriately matched with payment for a security. Therefore, the Commission believes the use of a DVP method promotes the clearing agency's ability to facilitate prompt and accurate clearance and settlement.¹¹¹

4. Maintenance of Fair Competition among Market Participants

Section 17A of the Exchange Act also directs the Commission to have due regard for the maintenance of fair competition in the use of its authority under Section 17A of the Exchange Act.¹¹² EB states that approving the Modification Application may improve competition among

¹⁰⁸ See Modification Application, Exhibit K-5 at 83.

¹⁰⁹ See Modification Application, Exhibit K-5 at 127.

¹¹⁰ See Clearing Agency Standards, Exchange Act Release No. 68080 (Oct. 22, 2012), 77 FR 66220, 66256 (Nov. 2, 2012).

¹¹¹ Id.

¹¹² See 15 U.S.C. 78q-1(a)(2)(A).

market participants offering collateral management services, but does not expect it to have any impact on the current competitive landscape for provision of settlement of transactions in U.S. Equity Securities for U.S. Participants.¹¹³ EB notes that U.S. Participants already use the EB-CMS today for U.S. Government Securities, but are disadvantaged compared to non-U.S. participants in the range of collateral that they are able to mobilize to meet their collateral obligations in that they are currently unable to use U.S. Equity Securities within the EB-CMS. As a result, EB's proposed service would reduce the disparity between U.S. and non-U.S. participants. EB also states that U.S. Participants currently have, and would continue to have the option of providing U.S. Equity Securities as collateral by using the services of a market intermediary that is not regulated by the Commission as a clearing agency (typically a bank) or by making bilateral collateral management arrangements and undertaking collateral management activities themselves.¹¹⁴ Accordingly, the Commission preliminarily believes that the Modification Application is consistent with Section 17A of the Exchange Act because the Modification Application should facilitate fair competition between U.S. and non-U.S. participants, and would not prevent U.S. Participants from using other comparable services that may be available.

C. Proposed Conditions

EB represents in its Form CA-1 that it would comply with a series of conditions, as described further below, which are designed to establish an appropriately robust regulatory framework over the limited range of Clearing Agency Activities EB proposes to offer. These conditions are set forth in three sections: (A) continuation of two existing conditions applicable

¹¹³ See Modification Application, Exhibit S-1 at 21.

¹¹⁴ See Modification Application, Exhibit S-1 at 22.

to the U.S. Government Securities Clearing Agency Activities, (B) operational risk conditions applicable to the Clearing Agency Activities, and (C) additional conditions applicable to the Clearing Agency Activities.

With respect to Section B, the Commission preliminarily believes that the conditions constitute a robust framework of operational conditions to be applied to those EB systems that facilitate the Clearing Agency Activities. Under the Existing Exemption, EB was not subject to the Commission's Automated Review Policy.¹¹⁵ As a result, EB does not meet the definition of SCI entity as set forth in Rule 1000 of Regulation SCI, and is therefore not subject to the Commission's Regulation Systems Compliance and Integrity ("Regulation SCI").¹¹⁶ The Commission preliminarily believes that it is appropriate to apply operational conditions that would require EB to have sufficiently resilient systems to support the limited services upon which U.S. Participants may rely.

The proposed conditions in Part VI.C are tailored to the operations of the Clearing Agency Activities and seek to address the same policy concerns that were addressed by Regulation SCI, specifically the reduction of the occurrence of systems issues, the improvement of resiliency of systems, and the enhancement of the Commission's oversight and enforcement of technology infrastructure. The Commission believes that resiliency conditions are warranted because an operational disruption at EB could impact U.S. Participants. The Commission understands that EB would use the same set of collateral management applications and core settlement processing infrastructure housed in the Euroclear System for the U.S. Equities

¹¹⁵ See Exchange Act Release Nos. 27445 (Nov. 16, 1989), 54 FR 48703 (Nov. 24, 1989), and 29185 (May 9, 1991), 56 FR 22490 (May 15, 1991).

¹¹⁶ See Regulation Systems, Compliance and Integrity, Exchange Act Release No. 73639 (Nov. 19, 2015), 79 FR 72252 (Dec. 5, 2014).

Clearing Agency Activities as it uses for the U.S. Government Securities Clearing Agency Activities, so the operational conditions would apply across both distinct sets of activities.

Several of the proposed conditions in Part VI.D are reformulations of general disclosure and notification conditions that apply generally to EB's operations in performing the U.S. Government Securities Clearing Agency Activities, as previously applied under the Existing Exemption. Specifically, conditions D.3, D.5 and D.7 are taken from the Original Exemption Order and would be applied to the Clearing Agency Activities. Likewise, the conditions would continue to require EB to (i) respond to Commission requests for information concerning financial solvency concerns of U.S. Participants and (ii) file amendments to its application for exemption on Form CA-1 if it makes any material change to the Clearing Agency Activities to allow the Commission to perform ongoing monitoring of any future modified order.

Additionally, the Commission preliminarily believes that the routine provision of certain information by EB would be appropriate to facilitate the monitoring of the impact of EB's expanded, but still limited, Clearing Agency Activities on the national clearance and settlement system. The conditions would expand the reporting conditions as a result. Under the Original Exemption Order, the Commission required EB to provide to the Commission any disclosure documents provided to Euroclear System participants, such as any amendments to the terms and conditions governing the service, any changes to the operating procedures of the Euroclear System, the annual shareholder report, and the annual internal controls report.¹¹⁷ Under proposed condition D.2, EB would be required to notify the Commission of any material changes to any service agreement between it and any other entity that is performing Clearing Agency Activities. Under proposed condition D.4, EB would provide the Commission an annual report

¹¹⁷ See Original Exemption Order, *supra* note 1, at 8240.

that would describe material changes that do not otherwise necessitate the filing of an amendment of the Form CA-1. The annual report would further require a description of the functioning of EB's monitoring its own compliance and the compliance of third-party service providers with conditions of any modified order. Finally, the annual report would require a description of the management of any conflicts of interest between EB and an affiliated or third-party service provider. The Commission preliminarily believes the notification and annual reporting conditions would facilitate the general monitoring of the Clearing Agency Activities, and in particular, the contractual and operational relationships between EB and ESA, as well as between EB and DTCC. ESA and DTCC, through the Euroclear System and DEGCL, respectively, could play instrumental roles in the EB-CMS, and the Commission preliminarily believes that ongoing updates on these relationships are appropriate to allow the Commission the ability to assess EB's reliance on affiliates to perform clearing agency functions related to the Clearing Agency Activities.

The Commission also preliminarily believes that the new recordkeeping and examination conditions would help the Commission assess EB's compliance with the conditions of any future modified order. Under conditions C.8 and D.5, EB would be required to keep records of documents relating to compliance with the operational conditions and records pertaining to the Clearing Agency Activities covered within the scope of the modified exemption. Under condition D.6, EB would be required to respond to information requests and to allow on-site inspections of facilities, records, and personnel for the purpose of reviewing the Clearing Agency Activities' operations and compliance with the federal securities laws and any future modified order issued by the Commission. The recordkeeping and examination conditions should facilitate periodic review of EB's adherence to the conditions. Finally, under condition D.1, EB

would be required to provide annual audited financial statements prepared by competent independent audit personnel, to assist the Commission's monitoring of EB's ongoing condition.

VI. Conditions to Exemption from Clearing Agency Registration

As mentioned above, EB represents in its Form CA-1 that it would comply with all of the conditions described below. EB believes that these conditions are consistent with the public interest, the protection of investors, and the purposes of Section 17A of the Exchange Act.

The following set of conditions, which would replace and supersede all conditions set forth in the Existing Exemption, to read as follows:

A. Continuation of Existing Conditions Applicable to the U.S. Government Securities Clearing Agency Activities

(1) The average daily volume of eligible U.S. Government Securities processed for U.S. Participants through EB as operator of the Euroclear System may not exceed five percent of the total average daily dollar value of the aggregate volume in eligible U.S. Government Securities.

(2) EB will provide the Commission with quarterly reports, calculated on a twelve-month rolling basis, of (a) the average daily volume of transactions in eligible U.S. Government Securities for U.S. Participants that are subject to the volume limit and (b) the average daily volume of transactions in eligible U.S. Government Securities for all Euroclear System participants.

B. Condition Applicable to the U.S. Equities Clearing Agency Activities

EB shall provide to the Commission or its designee quarterly reports, calculated on a twelve-month rolling basis, of (1) the average daily value of U.S. Equity Securities that are held in Collateral Accounts at EB for U.S. Participants and a break-down of the general types of EB collateral agreements in respect of which such value is given as collateral, (2) the average daily value of U.S. Equity Securities that are held in EB's account at DTC relating to inventory

management services, and (3) the total value, and a break-down of the general types of EB collateral agreements in respect of which such value is given as collateral, of U.S. Equity Securities that are transferred from Collateral Accounts of U.S. Participants at EB to other Securities Clearance Accounts at EB (other than IMS-Linked Accounts) pursuant to a liquidation of such collateral.

C. Operational Risk Conditions Applicable to Clearing Agency Activities

(1) EB shall demonstrate to the Commission or its designee prior to commencing the U.S. Equities Clearing Agency Activities that EB maintains written policies and procedures applicable to those systems that support or are integrally related to the Clearing Agency Activities (the “Systems”) that, on an ongoing basis, are reasonably designed to:

(a) establish a robust operational risk-management framework applicable to the Systems with appropriate systems, policies, procedures, and controls to identify, monitor, and manage operational risks;

(b) clearly define the roles and responsibilities of EB personnel for addressing operational risk (e.g., identify a senior manager responsible for compliance with the operational conditions applicable to the Systems);

(c) review operational policies, procedures, and controls applicable to the Systems;

(d) audit the Systems, and test the Systems periodically and at implementation of significant changes;

(e) clearly define operational reliability objectives for the Systems;

(f) ensure that the Systems have scalable capacity adequate to handle increasing stress volumes and achieve the Systems service-level objectives;

(g) establish comprehensive physical and information security policies that address all potential vulnerabilities and threats to the Systems;

(h) establish a business continuity plan for the Systems that addresses events posing a significant risk of disrupting the Systems' operations, including events that could cause a wide-scale or major disruption in the provision of the Clearing Agency Activities;

(i) incorporate the use of a secondary site in EB's business continuity plan that is designed to ensure that the Systems can resume operations within two hours following disruptive events; and

(j) regularly test or otherwise validate EB's business continuity plans; and identify, monitor, and manage the risks that key participants, other financial market infrastructures, and service and utility providers might pose to the Systems' operations in relation to the Clearing Agency Activities.

(2) For purposes of condition C.1, such policies and procedures shall be consistent with current information technology industry standards, which shall be comprised of information technology practices that are widely available to information technology professionals in the financial sector and issued by a widely recognized organization. EB shall inform the Commission or its designee of the information technology industry standards that EB has chosen to use, affirm that choice on an annual basis, and provide advance notice of the use of different standards as soon as practicable.

(3) EB shall provide the Commission or its designee with an annual update on the status of the items set forth in condition C.1.

(4) EB shall establish, implement, maintain, and enforce written policies and procedures reasonably designed to ensure that the Systems operate on an ongoing basis in a manner that

complies with the conditions applicable to the Systems and with EB's rules and governing documents applicable to the Clearing Agency Activities.

(5)(a) Upon EB having a reasonable basis to conclude that a disruption, compliance issue, or intrusion of the Systems that impacts, or is reasonably likely to impact, the Clearing Agency Activities has occurred (a "Systems Event"), EB shall:

(i) take appropriate corrective action, which shall include, at a minimum, devoting adequate resources to remedy the Systems Event as soon as reasonably practical;

(ii) notify the Commission or its designee of such Systems Event within 24 hours after occurrence;

(iii) until such time as a Systems Event is resolved and EB's investigation of the Systems Event is closed, provide updates pertaining to such Systems Event to the Commission or its designee on a regular basis;

(iv) within 48 hours after the occurrence of a Systems Event or where EB reasonably determines that such deadline cannot be met and so notifies the Commission or its designee, promptly thereafter, submit an interim written notification pertaining to such Systems Event to the Commission or its designee containing: (A) a detailed description of: the relevant discovery and duration times, detection, root cause and remedial actions taken or planned regarding the Systems Event (to the extent known at report time); EB's assessment of the entities (including types of market participants) and EB services affected by the Systems Event; EB's assessment of the impact of the Systems Event on the Participants; and any other pertinent information known by the EB about the Systems Event; and (B) a copy of any information disseminated to EB's U.S. Participants in accordance with EB's notification practices regarding the Systems Event;

(v) within ten business days after the occurrence of a Systems Event, or where EB reasonably determines that such deadline cannot be met and so notifies the Commission or its designee, promptly thereafter, submit a written final report regarding the matters covered in the interim report required under (iii) above to the Commission or its designee; and

(vi) for Systems Events characterized as “Bronze level” events (i.e., a Systems Event in which the incident is clearly understood, almost immediately under control, involves only one business unit and/or entity, and is resolved within a few hours), in lieu of the reporting in (i) through (v) above, provide on a quarterly basis an aggregated list of Bronze level events.

(b) As used herein: (i) a “disruption” means an event in the Systems that disrupts, or significantly degrades, the normal operation of the Systems in relation to the Clearing Agency Activities; (ii) a “compliance issue” means an event at EB that has caused any System to operate in a manner that does not comply with the applicable conditions or EB’s rules and governing documents applicable to the Clearing Agency Activities; and (iii) an “intrusion” means any unauthorized entry into the Systems in relation to the Clearing Agency Activities.

(6) EB shall, within 30 calendar days after the end of each quarter, submit to the Commission or its designee a report describing completed, ongoing, and planned material changes to the Systems that support or are related to the Clearing Agency Activities during the prior, current, and subsequent calendar quarters, including the dates or expected dates of commencement and completion. EB shall establish reasonable written criteria for identifying a change to the Systems as material and report such changes in accordance with such criteria.

(7) EB shall provide the Commission or its designee with: (a) annually, the audited control report made available to EB’s Participants prepared in accordance with internationally accepted standards for assurance reports on controls at a service organization (such as the

International Standard on Assurance Engagements (ISAE) Standard No. 3402); (b) annually, copies of those portions of any annual control report provided by EB to its primary Belgian regulator that describes controls applicable to the Systems as used to support or in relation to the Clearing Agency Activities; and (c) copies of agendas, reports and presentation materials relating to the capacity, integrity, resiliency, availability, and security or compliance of the Systems that are provided by EB or its primary Belgian regulator to any committee of regulators that implements the memorandum of understanding among regulators of Euroclear Group's CSD entities that provides for the coordinated and common oversight and supervision of the Euroclear Group.

(8) EB shall make, keep, and preserve at least one copy of all documents relating to its compliance with the operational risk conditions; keep all such documents for a period of not less than five years, the first two years in an easily accessible place (which may be located in the European Union); and upon request of the Commission, promptly furnish to the possession of the Commission or its designee copies of any such documents.

D. Additional Conditions Applicable to the Clearing Agency Activities

(1) EB shall provide to the Commission or its designee its annual audited financial statements prepared by competent independent audit personnel.

(2) EB shall notify the Commission or its designee of any material changes to any service agreement between EB and any other entity that is performing Clearing Agency Activities on behalf of EB if such changes are reasonably expected to materially affect the Clearing Agency Activities.

(3) EB will notify the Commission or its designee (a) promptly following termination of any U.S. Participant as a participant in the Euroclear System, (b) promptly following the

liquidation by EB of any securities collateral pledged by a U.S. Participant to EB to secure an extension of credit made through the Euroclear System, and (c) promptly following EB becoming aware of the institution of any proceedings to have a U.S. Participant declared insolvent or bankrupt, and will respond to Commission requests for information about any U.S. Participant about whom the Commission has financial solvency concerns, including, for example, a settlement default by a U.S. Participant.

(4) EB shall annually provide to the Commission or its designee a report describing: (a) material changes to the representations made by EB in support of the approval of this Order that would not otherwise require amendment of EB's application for exemption on Form CA-1 in accordance with these conditions; (b) the functioning of EB's policies and procedures for monitoring its own compliance with the conditions of this order regarding the Clearing Agency Activities (and the compliance of any affiliated or third-party service provider referred to in condition D.2); and (c) the management by EB of any conflicts of interest of such affiliated or third-party service provider that EB becomes aware have arisen since the prior report with respect to the performance of the Clearing Agency Activities.

(5) EB shall keep records relating to the Clearing Agency Activities regarding settlement details, account details, service agreements, and service notices sent to U.S. Participants pertaining to the operation of the Clearing Agency Activities and retain such records for a period of not less than five years, the first two years in an easily accessible place (which may be located in the European Union).

(6) EB shall respond to and require its service providers to respond to a request from the Commission for additional information relating to the Clearing Agency Activities and provide access to the Commission or its designee to conduct on-site inspections of all facilities (including

automated systems and systems environment), records, and personnel related to the Clearing Agency Activities. The request for information shall be made and the inspections shall be conducted solely for the purpose of reviewing the Clearing Agency Activities' operations and compliance with the federal securities laws and the terms and conditions in any order exempting EB from registration as a clearing agency with regard to the Clearing Agency Activities.

(7) EB shall file with the Commission amendments to its application for exemption on Form CA-1 if it makes any material change to the Clearing Agency Activities or any change materially affecting the Clearing Agency Activities as summarized in the relevant exemption order, EB's amended Form CA-1 or in any subsequently filed amendments to its Form CA-1 that would make such previously provided information incomplete or inaccurate.

VII. Solicitation of Comments

Interested persons are invited to submit written data, views, and arguments concerning the foregoing, including whether the proposed exemption is consistent with the public interest, the protection of investors, and the purposes of Section 17A of the Exchange Act. To the extent possible, commenters are requested to provide empirical data and other factual support for their views. In addition, the Commission seeks comment generally on the following issues:

1. Would the Modification Application, if approved, achieve the underlying policy objectives of the Exchange Act? Why or why not? In particular, please address whether granting an exemption from registration does or does not further the goals of promoting investor protection and the integrity of the securities markets.
2. Are the proposed conditions to the Modification Application sufficient to promote the purposes of Section 17A of the Exchange Act and to allow the Commission to adequately

monitor the effects of EB's Clearing Agency Activities on the national system for the clearance and settlement of securities transactions? Why or why not?

3. EB has represented that its provision of the U.S. Equities Clearing Agency Activities would benefit U.S. Participants by providing a service to efficiently satisfy the New Collateral Regulations. Will the provision of the U.S. Equities Clearing Agency Activities provide those or other benefits? Will providing the service lead to lower costs, or higher costs, for U.S. Participants or other segments of the U.S. securities markets? What other benefits would U.S. Participants or other U.S. persons receive from these services?

4. Are there other providers of collateral management or related post-trade processing services that may be placed at a competitive advantage as a result of EB's account at DTC and the creation of DEGCL?

5. Similar to the volume limits placed on the U.S. Government Securities Clearing Agency Activities, should there be a volume limit on the U.S. Equities Clearing Agency Activities? If so, what should be the volume limit and why?

6. Are there potential issues or concerns that the Commission should consider? For example, differences between U.S. and Belgian law or other possible effects of the proposed Modification Application on the U.S. securities markets and investors.

Comments may be submitted by any of the following methods:

Electronic comments:

- Use the Commission's Internet comment form (<http://www.sec.gov/rules/proposed.shtml>); or
- Send an e-mail to rule-comments@sec.gov. Please include File Number 601-01 on the subject line; or

Paper comments:

- Send paper comments to Brent J. Fields, Secretary, Securities and Exchange Commission, 100 F Street, N.E., Washington, DC 20549-1090. All submissions should refer to File Number 601-01.

To help us process and review your comments more efficiently, please use only one method. The Commission will post all comments on the Commission's Internet website (<http://www.sec.gov/rules/other.shtml>).

Copies of the submission, all subsequent amendments, all written statements with respect to the application that are filed with the Commission, and all written communications relating to the application between the Commission and any person, other than those that may be withheld from the public in accordance with the provisions of 5 U.S.C. 552, will be available for website viewing and printing in the Commission's Public Reference Section, 100 F Street, NE, Washington, DC 20549 on official business days between the hours of 10:00 a.m. and 3:00 p.m.

All comments received will be posted without change; the Commission does not edit personal identifying information from submissions. You should submit only information that you wish to make available publicly. All submissions should refer to File Number 601-01 and should be submitted on or before [INSERT DATE 30 DAYS FROM THE DATE OF PUBLICATION IN THE FEDERAL REGISTER].

For the Commission by the Division of Trading and Markets, pursuant to delegated authority.¹¹⁸

Robert W. Errett
Deputy Secretary

¹¹⁸ 17 CFR 200.30-3(a)(16).