

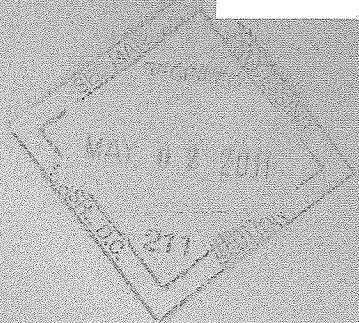

Power Secure



PowerSecure 2010 Annual Report

Disciplined *Innovation*

Technology for a Smarter Grid

“2010 was a transformational year for PowerSecure as we made great strides toward our long-term goals and we developed significant opportunities across each of our core business areas, including Energy Efficiency, Distributed Generation and Utility Infrastructure. Our successes and prospects for growth in these businesses carry a common thread – PowerSecure’s disciplined innovation in the development of technology for a smarter grid.”

Sidney Hinton, CEO, PowerSecure International, Inc.

To Our Shareholders

Fellow Shareholders:

As we reflect on 2010, we believe it will end up being the most transformational year in PowerSecure's history because of the investments we made for the benefit of our customers, utility partners and shareholders, and because of the foundation we have built for our future. We are very excited about the great position we are in due to the hard work of the PowerSecure team to further develop our capabilities and position the company for growth.

In 2010, we continued to drive the company toward our goal of exceeding \$300 million in revenue – a 25% compound growth rate – and achieving double-digit operating margins by 2015. While the overall economic recovery remained fragile, we identified significant medium- and long-term opportunities across each of our core business areas, including Energy Efficiency, Distributed Generation and Utility Infrastructure. Our successes and prospects for growth in these businesses carry a common thread – PowerSecure's disciplined innovation in the development of technology for a smarter grid.

The investments PowerSecure made in 2010 also broadened our product offerings and provided an even stronger overall set of revenue and profit catalysts. In our Energy Efficiency business we brought several new products to market, including our SecureLite™ and PowerLite™ LED street lights, our Efficient-Lights® LED lights for retailers' walk-in storage coolers and open refrigerated cases, and new LED lighting power driver technology. In our Distributed Generation business, we invested to further develop our new proprietary generating technology, and boosted our operational capabilities to efficiently produce these systems in large volumes. These new systems deliver enhanced operating efficiencies, improved air emissions, better fuel technology, a modular design for greater standardization, and lower maintenance costs. And in our Utility Infrastructure area we invested in equipment and personnel to serve several utilities that awarded us new transmission and distribution business. In addition, we invested in the development of our exciting new PowerSecure SmartStation™ and Micro-Grid products.

Our PowerSecure SmartStation provides utilities with a more efficient, turnkey substation product that offers enhanced information and communications flow, improved safety and performance, and a smaller footprint. Our new Micro-Grid enables a group of facilities to achieve grid autonomy – incorporating an array of power sources, including traditional generation as well as wind and solar power – and manages and prioritizes the distribution of the electrical load across the facilities for maximum efficiency. We are excited about the potential of each of these new capabilities and the exceptional value they can deliver to our utility partners and customers.

As we move forward in 2011, we are intentionally focused on maximizing the productivity of these investments, including maintaining vigilant financial discipline to deliver our full top- and bottom-line potential. We are pleased that our revenue backlog on March 10, 2011, stood at an all-time high of \$150 million, which was \$30 million higher than the same time last year, and our backlog is well-balanced with a combination of near- and long-term revenues. The entire PowerSecure team is also focused on eliminating unproductive costs and resources as we focus on our highest value opportunities.

The fundamental determinant of our success will be our ability to profitably serve our utility partners and customers with excellent products and services that deliver strong returns on their energy investments. At PowerSecure, our team approaches everything we do with this in mind, and always strives to exceed our customers' expectations. Each of our businesses is well positioned for 2011, and we look forward to reporting our continued progress as we work to unlock PowerSecure's full potential and drive shareholder value.

Sincerely,

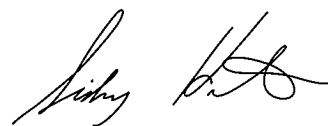

Sidney Hinton
Chief Executive Officer

Energy Efficiency Solutions



Retailers turn to our EfficientLights® division for LED lighting solutions that reduce energy use by 70 percent, lower maintenance costs and benefit the environment. Our in-store lighting products include lights for refrigerator and freezer case doors, walk-in coolers and open refrigerated case shelves.



EfficientLights® LED Lighting Products

EnergyLite® LED Lighting Products

Innovative Electronic Solutions – LED Lighting Components and Technologies

PowerSecure's flagship **Energy Efficiency** product, our **Efficient-Lights®** LED lighting fixtures for retailers' refrigerated and freezer cases, delivers a powerful return on our customers' investments by lowering their energy costs by 70 percent, reducing maintenance costs and improving the quality of lighting in stores. We are proud to say that we have installed more than 400,000 of these lights in grocery, drug and convenience stores across the United States. Based on the success of this product, our retail customers asked us to design additional LED lighting products for specific in-store applications, and in 2010 we introduced new lights for walk-in coolers and open refrigerated case shelves. We are excited about this expanded product portfolio and the potential to broaden the LED lighting solutions we are delivering to retailers through our EfficientLights brand of products.

In addition, PowerSecure's new family of **EnergyLite®** LED street lights is seeing strong adoption by utilities and municipalities.

Our **SecureLite™** product provides an energy-efficient and low-maintenance alternative to the 100 watt HID lighting traditionally used by utilities and municipalities. SecureLite delivers a 67 percent energy usage reduction compared to high-pressure sodium lights, extends lighting life three-fold and provides increased reliability, which reduces utilities' maintenance costs. SecureLite is also engineered to deliver better lighting quality to enhance visibility, minimize light pollution, and be Dark Sky compliant. It incorporates our breakthrough dusk-to-dawn control technology to maximize efficiency and reliability. In addition, our new **PowerLite™** products are designed to replace traditional 250 and 400 watt HID street lighting and deliver a similarly strong combination of increased energy efficiency, reduced maintenance costs and environmental benefits for higher-wattage applications. PowerSecure's street light fixtures have been engineered to deliver 30-plus years of service life, including the ability to replace the LEDs in the unit.

PowerSecure's expanding line of proprietary outdoor LED-based lighting products includes street lights, area lights and parking lot lights.

Our winning formula combines leading-edge power driver technology, thermal management, and optical designs to deliver our customers a significant performance edge.

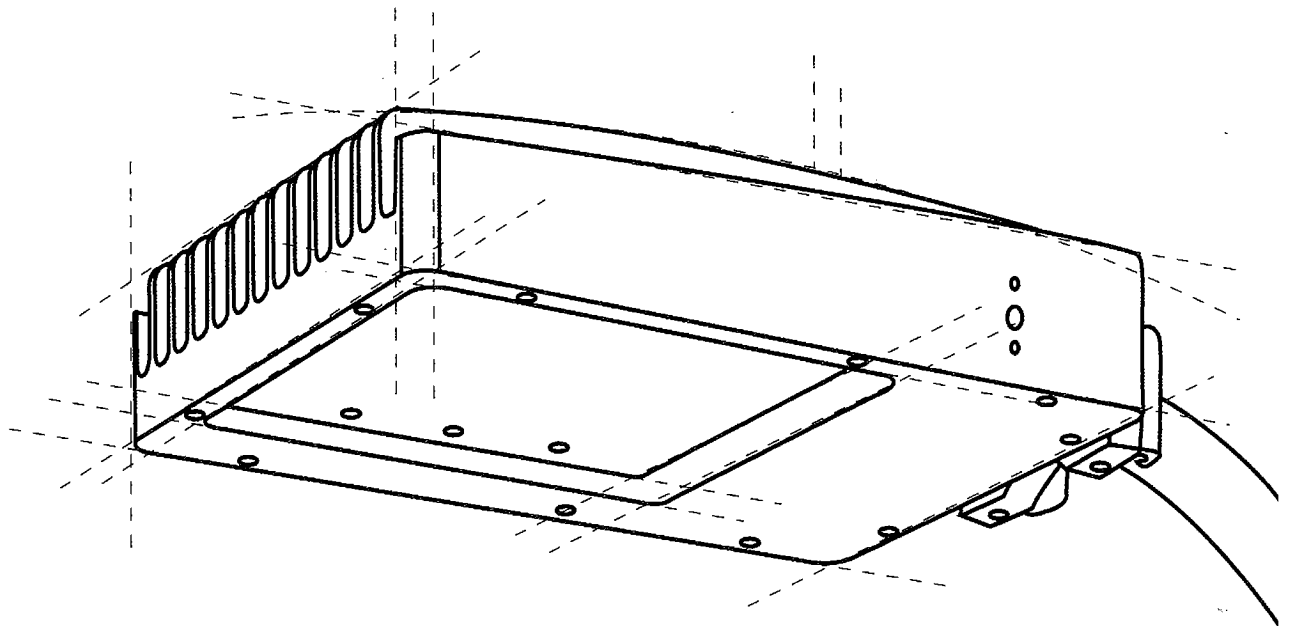
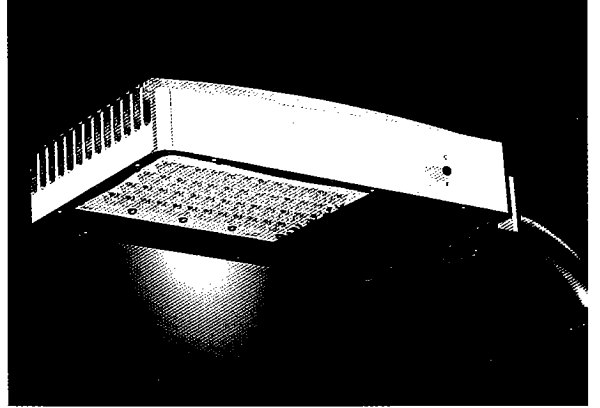
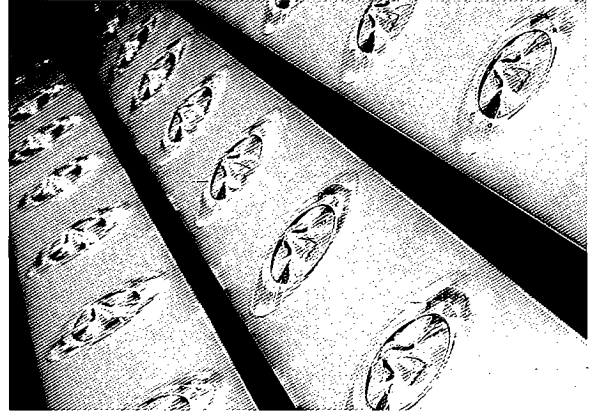

We engineered our new SecureLite™ and PowerLite™ LED street lights to deliver utilities and municipalities a strong combination of increased efficiency, reduced maintenance costs and benefits to the environment.

Interactive Distributed Generation® Solutions

Our Interactive Distributed Generation® (IDG®) systems stand ready to deliver backup power around the clock, and also allow businesses to manage their power usage during high-cost peak periods. Our systems provide powerful returns on investment and reduce vulnerabilities to power loss and the related risks.



Smart Grid Monitoring Center Interactive Distributed Generation® Systems NexGear® Switchgear Solutions

PowerSecure's **Interactive Distributed Generation® (IDG®)** Smart Grid power systems provide utilities and their customers efficient power during high-cost, peak-demand periods, and serve as a ready and reliable source of on-site standby power to protect against costly power interruptions. In addition, the systems deliver important environmental benefits because of their ability to address peak demand periods with optimal run times.

Every IDG system is electronically monitored 24/7 by PowerSecure's **Smart Grid Monitoring Center** to optimize peak shaving efficiencies and ensure standby power is always available. The Smart Grid Monitoring Center forecasts utilities' peak demand periods and electronically deploys the IDG systems to provide our customers significant reductions in their energy costs. At the same time, this helps our utility partners smooth their peak demand, delay new infrastructure investments for transmitting and distributing power, and minimize energy losses associated with moving electricity over long distances.

More than 1,000 IDG systems are currently in service for PowerSecure customers from coast to coast, including industrial manufacturers, food processors, retailers, distribution facilities, data centers, hospitals, municipal infrastructures, military installations and landfills. These highly productive IDG systems deliver value every day by generating strong returns on our customers' investments and serving as integral and indispensable assets to a wide variety of operations. In 2010, PowerSecure's IDG systems were deployed a record 12,745 times to deliver load management and demand response for our utility partners and customers – a 56 percent increase over 2009.

At PowerSecure, we custom-engineer our IDG systems for each facility they serve, with technology that provides our customers maximum benefits and deep confidence in our systems' ability to deliver power when they need it. Our proprietary **NexGear®** switchgear and electronic controls also ensure that power shifts between the utility grid and the IDG system are executed quickly and seamlessly with no power interruption, providing pain-free load management and demand response.

PowerSecure's NexGear® switchgear technology controls the IDG systems at our customers' facilities and manages seamless power shifts between the utility grid and the IDG systems with no service interruptions.

Our IDG systems help protect a wide range of business facilities, including hospitals, data centers, industrial facilities, retailers and public infrastructure – where power dependability is critical.

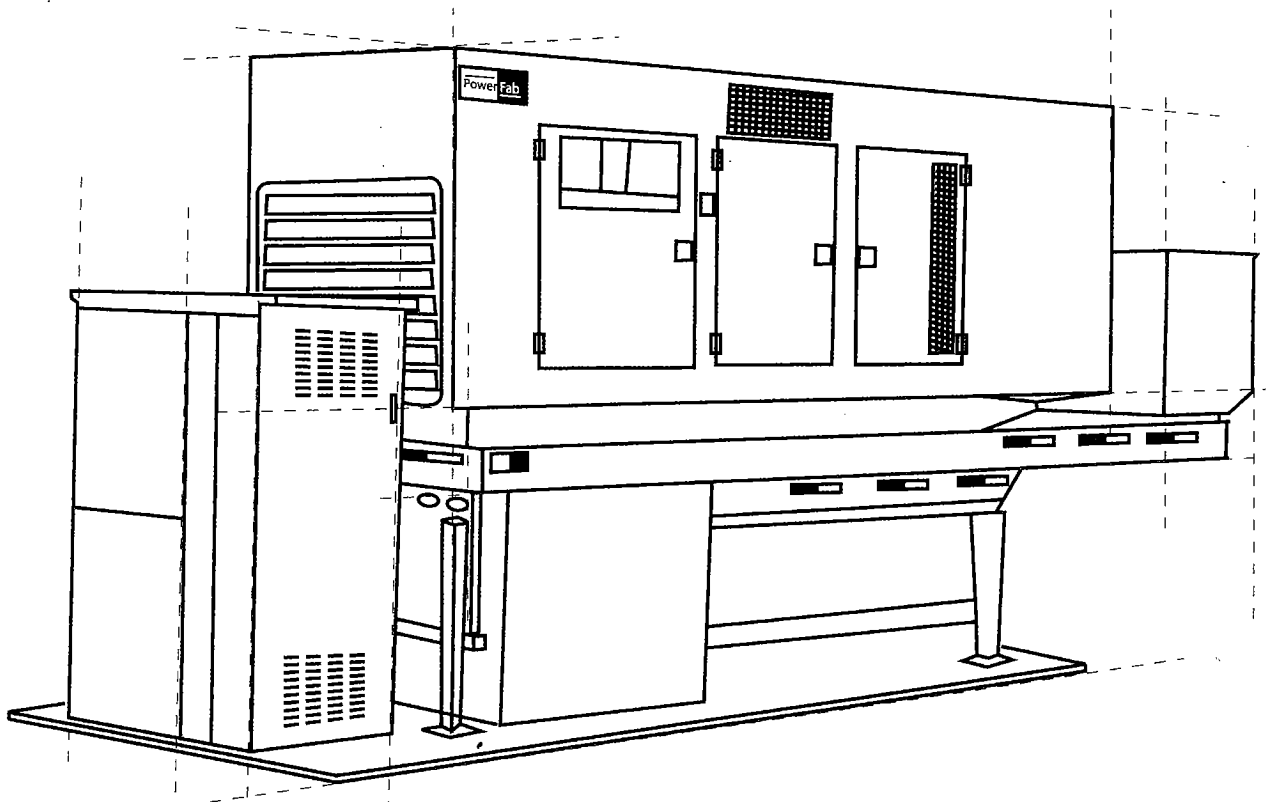
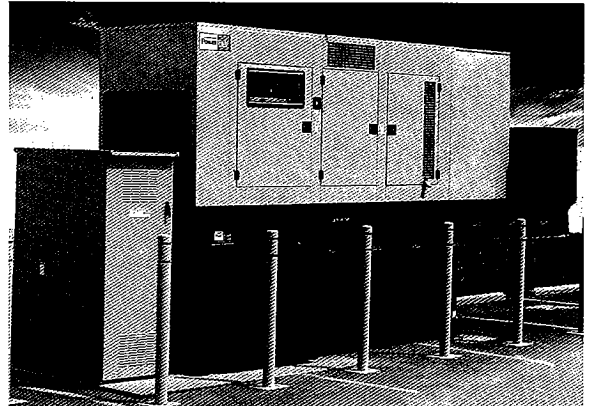
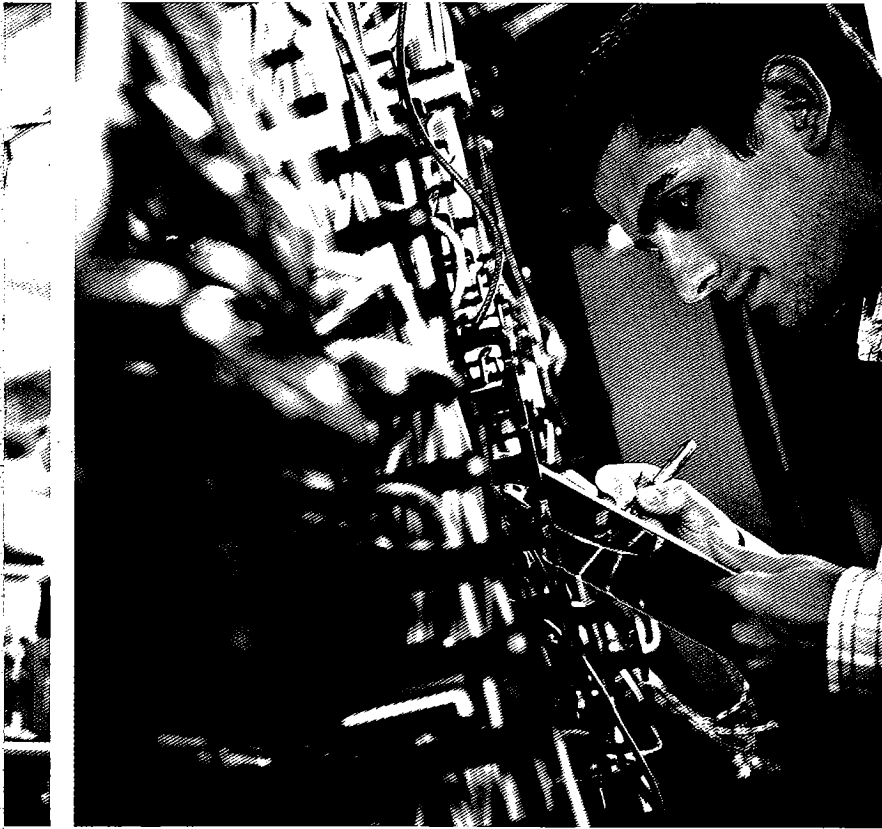

PowerSecure has installed more than 1,000 IDG systems, each custom-engineered for the operation it serves, providing unmatched dependability and optimized performance to maximize the ROI achieved by our customers and utility partners.

Utility Infrastructure Solutions

Our Utility Infrastructure businesses help utilities design and build infrastructure that enhances the efficiency and effectiveness of the nation's electric grid, including transmission and distribution design, construction and maintenance; substation products and services; advanced metering; lighting upgrades; and storm restoration services.

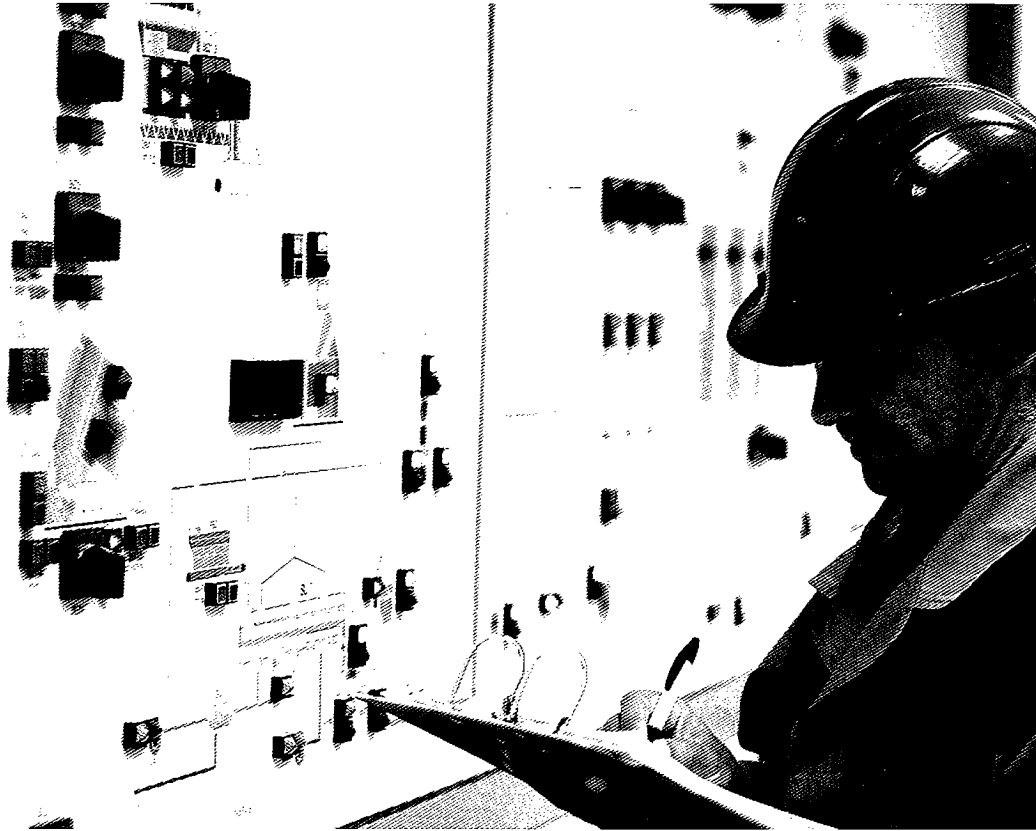

UtilityServices Transmission & Distribution Products and Services

UtilityEngineering Design and Engineering Services

PowerServices Utility Consulting Services

PowerSecure brings decades of experience to assisting investor-owned electric utilities, electric cooperatives and municipalities in their continual efforts to enhance, upgrade and improve the efficiency of their grid systems. Our client roster in the Utility Infrastructure area includes some of the largest, most sophisticated utility-power networks in the United States.

Our **UtilityEngineering** and **PowerServices** consulting engineering teams provide technical design and engineering services related to transmission and distribution systems, substations and lighting. Additionally, we serve utilities with management consulting services focused on areas such as planning and quality improvement, reliability analysis, rate studies, power supply contract consulting, and merger and acquisition support and analysis. Our teams draw upon deep, hands-on experience to deliver to our utility partners designs, analysis and advice that is smart, practical and grounded in a clear understanding of their unique needs.

PowerSecure's **UtilityServices** team provides utilities with transmission and distribution system construction and maintenance

services, substation installations, lighting upgrades and emergency storm restoration. We serve our utility partners with the best people in the industry, and deliver stand-out work that is executed with excellence.

We are also excited to announce the development of a new portfolio of proprietary products for our utility partners. First, the PowerSecure **SmartStation™** is a proprietary, fully enclosed substation that provides utilities with a more efficient design, enhanced information and communications, improved safety and performance, and a smaller footprint. In addition, PowerSecure's **Micro-Grid**, which has been co-developed with a Fortune 100 company, is designed to enable a group of facilities to achieve grid autonomy. This entails incorporating an array of power sources, including traditional generation as well as wind and solar power, and managing and prioritizing the distribution of the electrical load to maximize the efficiency of available power resources. Our goal is to continue to develop innovative products such as these to complement and enhance our service offerings to our utility partners and large industrial customers.

PowerSecure's Consulting Engineering team offers a comprehensive array of sophisticated electrical engineering and consulting services, leveraging decades of experience and serving as a trusted resource to our utility partners.

We also offer a proprietary line of turnkey products to our utility partners and large industrial customers, including our PowerSecure SmartStation™ and Micro-Grid.

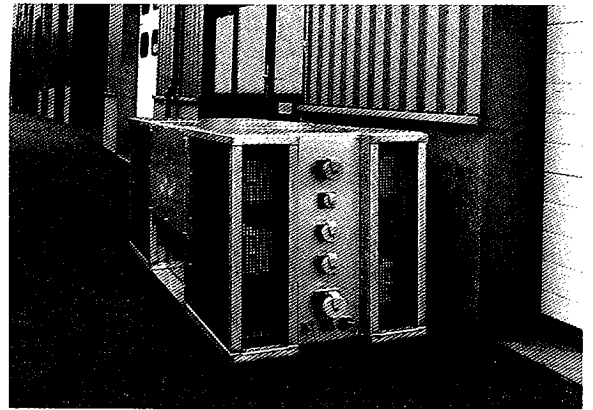
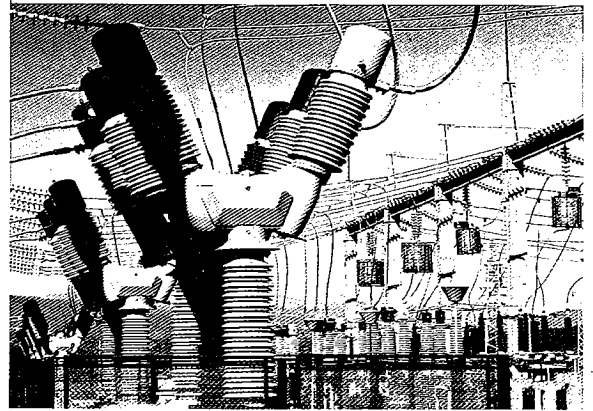

PowerSecure's breakthrough Micro-Grid technology provides energy autonomy to clusters of facilities in areas with unreliable or non-existent utility grids. It reduces fuel consumption and costs, incorporates solar and wind power, and enables electric vehicles to be charged by and provide power to the system.

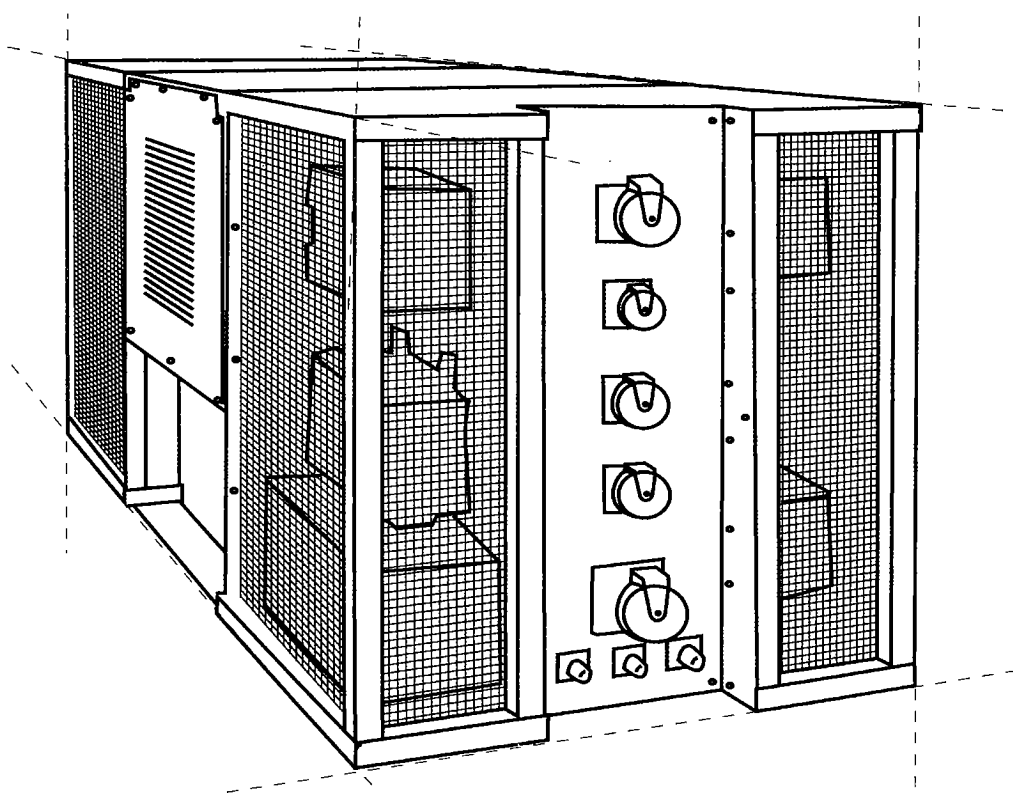

Board of Directors and Executive Officers

Anthony D. Pell
Director, Chairman of the Board and
Audit Committee Chairman
Senior Fiduciary Advisor,
Eaton Vance Investment Counsel

Kevin P. Collins
Director, Governance Committee Chairman
Managing Member, The Old Hill Company, LLC

John A. Miller
Director, Compensation Committee Chairman
Chairman and Chief Executive Officer,
Miller Consulting Group

Thomas J. Madden
Director, Risk Committee Chairman
Former Chairman and Chief Executive
Officer, ScottMadden Inc.

Sidney Hinton
Director
Chief Executive Officer and President
PowerSecure International, Inc.

Chris Hutter
Executive Vice President, Chief Financial Officer
and Treasurer
PowerSecure International, Inc.

Gary Zuiderveen
Vice President of Financial Reporting,
Controller, Principal Accounting Officer,
Asst. Treasurer and Secretary
PowerSecure International, Inc.

Shareholders' Information

Independent Registered Public
Accounting Firm
Hein & Associates, LLP
Denver, CO 80202

Legal Counsel
Kegler, Brown, Hill & Ritter Co., L.P.A.
Columbus, OH 43215

Transfer Agent
Computershare Investor Services
350 Indiana Street, Suite 750
Golden, CO 80401

Additional Information
Investors may request additional informa-
tion regarding PowerSecure International,
Inc., including copies of the Annual Report
on Form 10-K, free of charge by addressing
a request to:

Investor Relations
PowerSecure International, Inc.
1609 Heritage Commerce Court
Wake Forest, NC 27587
www.powersecure.com

Annual Meeting
June 13, 2011 at 9:00 a.m.
The Hampton Inn
12318 Wake Union Church Road
Wake Forest, NC 27587

Trading and Certification Information
The Company's Common Stock trades on The
NASDAQ Stock Market under the symbol "POWR".
The Company's CEO and CFO have filed with the
Securities and Exchange Commission all required
Certifications regarding the Company's public
disclosures in its 2010 periodic reports.

UNITED STATES
SECURITIES AND EXCHANGE COMMISSION
Washington, D.C. 20549

FORM 10-K

(Mark One)

ANNUAL REPORT PURSUANT TO SECTION 13 OR 15(d) OF THE SECURITIES EXCHANGE ACT OF 1934
For the fiscal year ended December 31, 2010

OR

TRANSITION REPORT PURSUANT TO SECTION 13 OR 15(d) OF THE SECURITIES EXCHANGE ACT OF 1934
For the transition period from _____ to _____

Commission file number: 001-12014

POWERSECURE INTERNATIONAL, INC.

(Exact name of Registrant as specified in its charter)

Delaware

(State or other jurisdiction of
incorporation or organization)

84-1169358

(I.R.S. Employer
Identification No.)

**1609 Heritage Commerce Court
Wake Forest, North Carolina 27587**

(Address of principal executive offices, including zip code)

Registrant's telephone number, including area code: **(919) 556-3056**

Securities registered pursuant to Section 12(b) of the Act:

<u>Title of each class</u>	<u>Name of each exchange on which registered</u>
Common Stock, par value \$.01 per share	The NASDAQ Stock Market LLC (NASDAQ Global Select Market)

Securities registered pursuant to Section 12(g) of the Act:

None

Indicate by check mark if the Registrant is a well-known seasoned issuer, as defined in Rule 405 of the Securities Act. Yes No

Indicate by check mark if the Registrant is not required to file reports pursuant to Section 13 or 15(d) of the Exchange Act. Yes No

Indicate by check mark whether the Registrant (1) has filed all reports required to be filed by Section 13 or 15(d) of the Securities Exchange Act of 1934 during the preceding 12 months (or for such shorter period that the registrant was required to file such reports), and (2) has been subject to such filing requirements for the past 90 days. Yes No

Indicate by check mark whether the Registrant has submitted electronically and posted on its corporate Web site, if any, every Interactive Data File required to be submitted and posted pursuant to Rule 405 of Regulation S-T (Section 232.405 of this chapter) during the preceding 12 months (or for such shorter period that the Registrant was required to submit and post such files). Yes No

Indicate by check mark if disclosure of delinquent filers pursuant to Item 405 of Regulation S-K is not contained herein, and will not be contained, to the best of registrant's knowledge, in definitive proxy or information statements incorporated by reference in Part III of this Form 10-K or any amendment to this Form 10-K.

Indicate by check mark whether the Registrant is a large accelerated filer, an accelerated filer, a non-accelerated filer or a smaller reporting company. See the definitions of "large accelerated filer," "accelerated filer" and "smaller reporting company" in Rule 12b-2 of the Exchange Act. (Check one):

Large accelerated filer Accelerated filer Non-accelerated filer Smaller reporting company
(Do not check if a smaller reporting company)

Indicate by check mark whether the Registrant is a shell company (as defined in Rule 12b-2 of the Exchange Act). Yes No

As of June 30, 2010, the last business day of the Registrant's most recently completed second fiscal quarter, the aggregate market value of the shares of the Registrant's Common Stock held by non-affiliates of the Registrant was approximately \$157,710,455, based upon \$9.09, the last sale price of the Common Stock on such date as reported on The NASDAQ Stock Market.

As of March 1, 2011, 18,738,764 shares of the Registrant's Common Stock were outstanding.

DOCUMENTS INCORPORATED BY REFERENCE

Portions of the Registrant's definitive Proxy Statement for the 2011 Annual Meeting of Stockholders, which will be filed with the Securities and Exchange Commission not later than 120 days after the end of the Registrant's fiscal year ended December 31, 2010, are incorporated by reference in Part III of this Annual Report on Form 10-K to the extent stated herein.

POWERSECURE INTERNATIONAL, INC.

Form 10-K

For the Fiscal Year Ended December 31, 2010

TABLE OF CONTENTS

Page

Cautionary Note Regarding Forward-Looking Statements	1
--	---

PART I

Item 1. Business	3
Item 1A. Risk Factors	21
Item 1B. Unresolved Staff Comments	46
Item 2. Properties.....	46
Item 3. Legal Proceedings	46
Item 4. (Removed and Reserved)	46

PART II

Item 5. Market for Registrant's Common Equity, Related Stockholder Matters and Issuer Purchases of Equity Securities.....	47
Item 6. Selected Financial Data	48
Item 7. Management's Discussion and Analysis of Financial Condition and Results of Operations.....	50
Item 7A. Quantitative and Qualitative Disclosures About Market Risk	81
Item 8. Financial Statements and Supplementary Data	81
Item 9. Changes in and Disagreements with Accountants on Accounting and Financial Disclosure.....	81
Item 9A. Controls and Procedures.....	82
Item 9B. Other Information.....	84

PART III

Item 10. Directors, Executive Officers and Corporate Governance	85
Item 11. Executive Compensation	85
Item 12. Security Ownership of Certain Beneficial Owners and Management and Related Stockholder Matters.....	85
Item 13. Certain Relationships and Related Transactions, and Director Independence	85
Item 14. Principal Accountant Fees and Services.....	85

PART IV

Item 15. Exhibits and Financial Statement Schedules	86
Index to Financial Statements	F-1
Signatures.....	S-1
Exhibit Index.....	X-1

CAUTIONARY NOTE REGARDING FORWARD-LOOKING STATEMENTS

This Annual Report on Form 10-K and the documents incorporated into this report by reference contain forward-looking statements within the meaning of and made under the safe harbor provisions of Section 27A of the Securities Act of 1933 and Section 21E of the Securities Exchange Act of 1934. From time to time in the future, we may make additional forward-looking statements in presentations, at conferences, in press releases, in other reports and filings and otherwise. Forward-looking statements are all statements other than statements of historical fact, including statements that refer to plans, intentions, objectives, goals, strategies, hopes, beliefs, projections, prospects, expectations or other characterizations of future events or performance, and assumptions underlying the foregoing. The words “may,” “could,” “should,” “would,” “will,” “project,” “intend,” “continue,” “believe,” “anticipate,” “estimate,” “forecast,” “expect,” “plan,” “potential,” “opportunity” and “scheduled,” variations of such words, and other comparable terminology and similar expressions are often, but not always, used to identify forward-looking statements. Examples of forward-looking statements include, but are not limited to, statements about the following:

- our prospects, including our future business, revenues, expenses, net income, margins, profitability, cash flow, cash position, liquidity, financial condition and results of operations, our targeted growth rate and our expectations about realizing the revenue in our backlog and in our sales pipeline;
- the effects on our business, financial condition and results of operations of current and future economic, business, market and regulatory conditions, including the current challenging economic and market conditions and their adverse effects on our customers and their capital spending and ability to finance purchases of our products, services, technologies and systems;
- the effects of fluctuations in sales on our business, revenues, expenses, net income, margins, profitability, cash flow, liquidity, financial condition and results of operations;
- our products, services, technologies and systems, including their quality and performance in absolute terms and as compared to competitive alternatives, their benefits to our customers and their ability to meet our customers' requirements, and our ability to successfully develop and market new products, services, technologies and systems;
- our markets, including our market position or market share;
- our ability to successfully develop, operate, grow and diversify our operations and businesses;
- our business plans, strategies, goals and objectives, and our ability to successfully achieve them;
- the effects on our financial condition, results of operations and prospects of the sale of our Southern Flow business and our strategy to monetize our non-core assets where beneficial;
- the sufficiency of our capital resources, including our cash and cash equivalents, funds generated from operations, availability of borrowings under our credit and financing arrangements and other capital resources, to meet our future working capital, capital expenditure, lease and debt service and business growth needs;
- the value of our assets and businesses, including the revenues, profits and cash flow they are capable of delivering in the future;
- industry trends and customer preferences and the demand for our products, services, technologies and systems;
- the nature and intensity of our competition, and our ability to successfully compete in our markets;
- fluctuations in our effective tax rates;
- business acquisitions, combinations, sales, alliances, ventures and other similar business transactions and relationships; and
- the effects on our business, financial condition and results of operations of litigation, warranty claims and other claims and proceedings that arise from time to time.

Any forward-looking statements we make are based on our current plans, intentions, objectives, goals, strategies, hopes, beliefs, projections and expectations, as well as assumptions made by and information currently available to management. Forward-looking statements are not guarantees of future performance or events, but are subject to and qualified by substantial risks, uncertainties and other factors, which are difficult to predict and are often beyond our control. Forward-looking statements will be affected by assumptions and expectations we might

make that do not materialize or that prove to be incorrect and by known and unknown risks, uncertainties and other factors that could cause actual results to differ materially from those expressed, anticipated or implied by such forward-looking statements. These risks, uncertainties and other factors include, but are not limited to, those described in "Item 1A. Risk Factors" below, as well as other risks, uncertainties and factors discussed elsewhere in this report, in documents that we include as exhibits to or incorporate by reference in this report, and in other reports and documents we from time to time file with or furnish to the Securities and Exchange Commission. In light of these risks and uncertainties, you are cautioned not to place undue reliance on any forward-looking statements that we make.

Any forward-looking statements contained in this report speak only as of the date of this report, and any other forward-looking statements we make from time to time in the future speak only as of the date they are made. We undertake no duty or obligation to update or revise any forward-looking statement or to publicly disclose any update or revision for any reason, whether as a result of changes in our expectations or the underlying assumptions, the receipt of new information, the occurrence of future or unanticipated events, circumstances or conditions or otherwise.

PART I

Item 1. Business

Company Overview

PowerSecure International, Inc., headquartered in Wake Forest, North Carolina, is a leading provider of Energy and Smart Grid Solutions to electric utilities and their commercial, institutional and industrial customers, and of Energy Services to oil and natural gas producers.

Our core business is our Energy and Smart Grid Solutions segment, which we operate through our primary wholly-owned subsidiary PowerSecure, Inc., which we refer to as "our PowerSecure subsidiary." In this business segment we conduct our operations through our three core strategic business areas: Interactive Distributed Generation, Utility Infrastructure and Energy Efficiency. These three business areas are focused on providing utilities and their commercial, institutional and industrial customers with products and services to help them generate, deliver and utilize electricity more efficiently and are intended to deliver strong returns on investment. They share common or complementary utility relationships and customer types, common sales and overhead resources, and use of the same facilities. However, each business area in this segment possesses distinct technical disciplines and specific capabilities that are designed to provide a competitive advantage in the marketplace for its specific products and services, including personnel, technology, engineering and intellectual capital. We operate the business areas in this segment primarily out of our Wake Forest, North Carolina headquarters office, although we also conduct our operations in this segment through several satellite office and manufacturing facilities, the largest of which are in Raleigh, North Carolina, Randleman, North Carolina, McDonough, Georgia, and Anderson, South Carolina. The locations of our sales organization for our core business segment are generally in close proximity to the utilities and to the commercial, industrial and institutional customers they serve.

We conduct our non-core business through our Energy Services segment. Until recently, our Energy Services segment was operated through two principal operating subsidiaries, Southern Flow Companies, Inc., which we refer to as "Southern Flow," and WaterSecure Holdings, Inc., which we refer to as "WaterSecure." However, as part of our strategy to monetize our non-core assets to focus on the businesses in our Energy and Smart Grid Solutions business segment, we sold our Southern Flow business effective January 1, 2011. Southern Flow provides oil and natural gas measurement services to customers involved in oil and natural gas production, transportation and processing, with a focus on the natural gas market. Since the sale of Southern Flow, our Energy Services segment has consisted only of our WaterSecure business. WaterSecure holds an investment of approximately 40% of the equity interests in an unconsolidated business, Marcum Midstream 1995-2 Business Trust, which we refer to as "MM 1995-2" or as our "WaterSecure operations." Our WaterSecure operations provide water processing, recycling, and disposal services for oil and natural gas producers in northeastern Colorado utilizing environmentally responsible technologies and processes.

The following chart summarizes our business segments, our strategic business areas, our business lines and the products and services they provide, as well as the subsidiaries under which each business is organized:

Business Segment	Strategic Business Area	Business Line and Primary Products and Services	Subsidiary
Energy and Smart Grid Solutions (Our Core Business Segment)	Interactive Distributed Generation	Interactive Distributed Generation® power systems, smart grid monitoring for electric utilities, peak shaving and demand response, standby power dispatch and control	PowerSecure, Inc.
		NexGear® switchgear products and systems	PowerSecure, Inc.
	Utility Infrastructure	UtilityServices utility infrastructure products and services, including transmission and distribution system construction and maintenance	PowerSecure, Inc.
		UtilityEngineering and PowerServices engineering, regulatory consulting, and electric grid system design	PowerSecure, Inc.
	Energy Efficiency	EfficientLights® LED lighting for grocery, drug, and convenience stores	PowerSecure, Inc.
		IES LED lighting and lighting components for OEM's, electronics manufacturers, and commercial, industrial, and consumer lighting applications	PowerSecure, Inc.
EnergyLite lighting and efficiency products for commercial and industrial customers, including street lights and area lights for utilities and municipalities		PowerSecure, Inc.	
Energy Services (Our Non-core Business Segment)	Energy Services	Southern Flow oil and natural gas measurement products and services (Sold effective January 1, 2011)	Southern Flow Companies, Inc.
		WaterSecure® water processing and disposal services for oil and natural gas producers	WaterSecure Holdings, Inc.

In this report, references to "PowerSecure," "we", "us", and "our" mean PowerSecure International, Inc. together with its subsidiaries, and references to "our PowerSecure subsidiary" means our PowerSecure, Inc. subsidiary along with the subsidiaries of PowerSecure, Inc., unless we state otherwise or the context indicates otherwise.

Recent Developments

On April 1, 2010, we launched an expansion of our light-emitting diodes, or LED, lighting business through the acquisition of a two-thirds controlling interest in Innovative Electronic Solutions Lighting, LLC, which we refer to as "IES." IES acquired substantially all of the assets and business of a leading LED lighting development company, accelerating our expansion of new LED lighting products and providing the means for us to capitalize on the growing marketplace for LED lighting. IES designs and manufactures new LED-based lighting products for commercial, industrial and retail customers. The business of IES includes turn-key product development, engineering and manufacturing of solid state LED-based lights, including power drivers, light engines and thermal management solutions. IES' expertise and technology enables the design and manufacture of high quality LED lighting products with strong competitive advantages that are driven by their ability to maximize the energy efficiency savings for given light outputs. IES' manufacturing operations are located in the Raleigh, North Carolina area.

Our PowerSecure Subsidiary owns two-thirds of the membership interests in, and controls the management of, IES. Our PowerSecure Subsidiary contributed approximately \$4.4 million to IES to fund the capitalization of IES and the acquisition by IES of substantially all of the assets and business of the seller as well as the assumption by IES of the seller's current liabilities. In connection with its sale and contribution of substantially all of its assets and business to IES, the seller received the remaining one-third of the membership interest in IES. Both our PowerSecure subsidiary and the seller are subject to various buy-sell rights and obligations with respect to their equity interests in IES, including, commencing in 2012, our right to acquire the remaining one-third minority interest in IES currently held by the seller in exchange for shares of our common stock in an amount equal to the value of that minority interest.

On April 30, 2010, through our PowerSecure subsidiary, which owned two-thirds of the equity interests in EfficientLights, we exercised our option and acquired the remaining one-third minority interest in EfficientLights in exchange for 1,025,641 shares of our common stock. The minority interests in EfficientLights were previously owned by the founder, who is also the President, of EfficientLights and by five other key employees of EfficientLights. EfficientLights markets and sells LED-based lights that reduce the energy and maintenance costs of lighting in grocery, drug and convenience stores, and is in the process of developing other LED-based lighting products, including LED-based parking lot lights, street lights and security lights. As a result of this acquisition, EfficientLights became a wholly-owned subsidiary of our PowerSecure subsidiary and after the date of acquisition there is no reduction in our consolidated net income due to the net income attributable to the noncontrolling interest in EfficientLights.

In continuation of our strategy to monetize our non-core assets to focus on the businesses in our Energy and Smart Grid Solutions segment, we sold our Southern Flow business, effective as of January 1, 2011, pursuant to a purchase and sale agreement dated December 30, 2010. Under the terms of the purchase agreement, Zedi, Inc., a Canadian corporation, through its wholly-owned U.S. subsidiary, purchased 100% of the stock of Southern Flow for \$16,515,000. In addition, we retained cash of approximately \$717,000 from excess working capital. Under the purchase agreement, we agreed to certain customary indemnification obligations for a period of 18 months after the closing of the sale. We will record a gain on the sale of Southern Flow in its results from discontinued operations during the first quarter of 2011. Southern Flow's operating results are reported as discontinued operations in our consolidated financial statements presented in this report.

The Industry, our Strategy, and our Business Areas of Focus

The U.S. electricity industry is large and has grown significantly over the last two decades. The U.S. electricity market totaled \$353 billion in end-user revenue, representing over 3,700 million megawatt hours consumed, in 2009. Throughout this period, utilities have been constrained in their ability to invest to meet this growth by an evolving and uncertain regulatory process, the increased burden of environmental constraints, and long lead times to complete major capital infrastructure investments. As a result, utilities are challenged to meet demand by traditional means, both in the areas of large scale power production and in power transmission and distribution. This has increased the strain on the electric power grid and, combined with higher input costs to produce electricity, has caused the price of electricity to increase over time. High electricity prices and costs to generate and deliver electricity are particularly pronounced during peak power periods, when the demand for electricity is at its highest. The rising demand for energy, growing cost of energy, and increasing concerns about the environment, have combined to cause virtually every organization, public and private, including utilities and their end customers, to be focused on energy efficiency and energy productivity. Approximately 60% of U.S. electricity demand is driven by commercial and industrial electricity usage.

These factors have generated a significant need in the marketplace for products and services in our Energy and Smart Grid Solutions segment, which consists of the following three strategic business areas: Interactive Distributed Generation, Utility Infrastructure and Energy Efficiency. Our strategy is to provide energy-related products and services in these areas that generate strong returns on investment for electric utilities and their commercial, institutional and industrial customers. Our business leaders and their teams have strong utility and customer relationships and a deep understanding of the markets we serve, and they are incentivized to grow these businesses profitably and prudently. Our company is highly entrepreneurial, and we encourage our business leaders to embrace a philosophy of disciplined innovation as a means to anticipate and fill customer needs. Our entrepreneurial culture is an asset that is fundamental to our growth and success. We are continually listening to our utility relationships, and to our existing and potential customers, to identify energy-related products and services we can deliver to add value to their businesses. We seek to fill these customer needs in several ways, including by:

- offering our existing portfolio of products and services that have demonstrated their value in similar or complementary situations, usually customizing them for each particular application;
- offering new energy-related technologies and capabilities that are emerging or being developed by third parties, which we can either incorporate into our existing product lines or bring to market as new product offerings; and
- developing new technologies and capabilities internally to serve existing and potential customers when options do not exist in the marketplace, that meet our quality, effectiveness, cost, and financial return standards.

Over the near and mid-term, we expect our primary strategic focus will be to continue to grow our businesses and to expand and enhance our product and service offerings in our Energy and Smart Grid Solutions segment, which is comprised of our Interactive Distributed Generation, Utility Infrastructure and Energy Efficiency businesses. Over the longer term, we expect to identify additional areas of business expansion that are complementary to these three businesses. In our Energy Services segment, which since January 2011 has been comprised solely of our WaterSecure business, we do not anticipate making additional investments, other than select high-return opportunities that can be self-funded using the cash flow generated by this business itself.

Our Interactive Distributed Generation Business

Overview

Our Interactive Distributed Generation business involves manufacturing, installing and operating electric generation equipment “on site” at the facility where the power is used, including commercial, institutional and industrial operations, generally on behalf of electric utilities. Our equipment provides a dependable backup power supply during power outages, and provides a more efficient and environmentally friendly source of power during high cost periods of peak power demand. Our Interactive Distributed Generation systems contain our proprietary electronic controls and software, which enable our systems to be monitored around the clock by our smart grid monitoring center, protecting our customers’ operations from power outages and their costs. Through our monitoring center, we also forecast utilities’ peak demand periods, and electronically deploy our systems during these periods to power the customers’ operations instead of drawing electricity from the utility grid. Our smart grid monitoring center ensures that our interactive distributed generation systems deliver more efficient and environmentally friendly power at optimal times and durations. This more efficient peak demand power supply benefits both the utility and the customer whose facility is being powered by the system. Our systems also enable utilities to delay new infrastructure investments for transmitting and distributing power, and minimize energy losses associated with moving electricity over long distances.

Market

The market for our Interactive Distributed Generation systems is driven by the multiple sources of value they provide. Both utilities and the customers they serve receive financial and operational benefits from our systems.

For utilities, our systems help them to:

- manage constraints in their electric grid systems, particularly during times of peak demand;
- minimize energy losses associated with moving electricity over long distances;
- manage challenges with respect to bottlenecks that can occur in electric transmission and distribution systems;
- perform localized system maintenance without interrupting large users of electricity in that particular area;
- operate with demand levels that are less volatile, enhancing the efficiency of their overall system and invested capital; and
- reduce carbon emissions compared to traditional sources of spinning power reserves.

For commercial, institutional and industrial customers, our systems help them by:

- providing a dependable source of backup power to protect their operations from financial losses and other negative consequences of power outages, including utilizing our systems both for preventative measures, such as when a storm is approaching, and for emergency purposes, when utility power is interrupted; and
- providing electricity cost savings by utilizing the systems to provide power during periods of high cost peak electricity demand, instead of drawing power from the utility grid, which is referred to as “peak shaving.”

Because utilities realize significant benefits when customers reduce the amount of power they draw from the electric grid during peak power periods, they generally provide incentives in their pricing, or tariff, structures to encourage this activity. These incentives are called “demand response” benefits and programs. Our systems are engineered to carry the full load required to operate the businesses they support, and our NexGear parallel

switchgear technology enables power to be transferred from the grid to our distributed generation system without any interruption. Therefore, customers who use our distributed generation systems can realize the financial benefits of utility demand response programs without the consequences, costs and inconveniences of having to interrupt or reduce the load of their operations.

Our Systems and Technology

We provide “turn-key” Interactive Distributed Generation systems and programs for our customers. The typical distributed generation system is installed and maintained at a utility’s end customer’s location and is designed to supply power only to that one particular site. The size of turn-key distributed generation systems that we have designed and installed has ranged from 90 kilowatts, or kW, to 30,000 kW, most commonly ranging from 500 kW to 4,500 kW, and we have the ability to design and install even larger systems.

The primary elements of our turn-key Interactive Distributed Generation systems include:

- designing and engineering the distributed generation system;
- obtaining the required regulatory approvals and permits;
- establishing the electricity inter-connect between the utility and the customer to take advantage of electricity rate savings;
- acquiring and installing the generators and other system equipment and controls;
- designing, engineering, constructing and installing the switchgear and process controls; and
- providing continuous 24 x 7 monitoring and servicing of the system.

One key component of a distributed generation system is its source of power generation, the generator, which is typically comprised of an alternator driven by a power source. While several types of distributed generation technologies are available, we currently utilize an internal combustion engine to power our distributed generation systems to provide maximum dependability. Typically these engines are fueled by diesel or a combination of natural gas and diesel, and they can also utilize methane or biodiesel as fuel. The types of generators, engines and alternators utilized in our systems are widely used and provide a dependable, cost-effective distributed generation technology, meaning that they are able to generate the power that is required with very short start-up times, with good efficiency at a reasonable cost. However, new power producing technologies are emerging, and we are continually evaluating the utilization of new technologies and their ability to be a commercially viable and reliable power source.

Internal combustion generators and engines range in individual size from 5 kW to 3,000 kW, while gas turbines range in individual size from 1,250 kW to 13,500 kW. Generating units can be installed individually or in multiple parallel arrangements, allowing us to service the needs of customers ranging from small commercial facilities to large industrial business sites.

Smart Grid Monitoring Center and NexGear® Technology

We build smart grid technology into our distributed generation systems. This technology is embedded into the design and manufacture of our proprietary switchgear and hardware and software controls systems, which are marketed under the name NexGear. Our NexGear technology controls the generator and the transfer of power, quickly shifting power between a customer’s primary power source and our Interactive Distributed Generation system. We consider our switchgear designs to be a source of competitive advantage for us due to their quality and their ability to provide power from the generator “in parallel with”, meaning at the same time as, the customer’s primary power source without disrupting the flow of electricity. This capability allows the customer to quickly substitute the power generated at the customer’s site with the power supplied by the utility power plant during times of peak demand without business interruption. Our system controls are built to enable remote monitoring and control functions, allowing us to operate the Interactive Distributed Generation system “24 x 7” from our monitoring center.

We believe our combination of unique smart grid capabilities is unmatched in the industry. Through our monitoring center, we lead the industry in our ability to monitor the electric power grid, proactively predict peak power periods, and electronically dispatch our customers’ generation at the right time, and for the right duration, with the goal of optimizing our customers’ energy efficiency. Peak power periods vary by geography, time of day, utility infrastructure, utility customer mix and weather. Using our predictive capabilities, we coordinate the

operation of our customers' Interactive Distributed Generation systems during times of peak demand so that our customers can benefit from energy savings and beneficial electricity rates that are available from managing energy use during these periods of high electricity prices. Our ability to enable our customers to benefit from these savings is enhanced by our expertise in understanding complicated utility rate structures.

Our monitoring center is an integral part of our distributed generation systems. We monitor and maintain our distributed generation systems for our customers around the clock, with the goal of ensuring reliability and removing many of the burdens associated with ownership. Distributed generation systems must be operated periodically so that they function properly when called upon to supply power. We remotely start and operate the systems using sophisticated communication devices, and we continuously monitor their performance. In the event of a mechanical problem, technicians are immediately dispatched. Additionally, for customers who already have generators on-site, we offer management services, including fuel management services, preventive and emergency maintenance services, and monitoring and dispatching services, to upgrade the performance of their stand-alone generators.

Business Models

Our Interactive Distributed Generation systems are sold to customers utilizing two basic economic models, each of which can vary depending on the specific customer and application. In our original business model, which is still our primary model, we sell the distributed generation system to the customer. We refer to this as the "project-based" or "customer-owned" model. For distributed generation systems sold under the project-based model, the customer acquires ownership of the distributed generation assets upon our completion of the project. Our revenues and profits from the sale of systems under this model are recognized over the period during which the system is installed. In the project-based model, we also usually receive a modest amount of on-going monthly revenue to monitor the system for backup power and peak shaving purposes as well as to maintain the system.

Our second business model is structured to generate long-term recurring revenues, which we refer to as our "recurring revenue model" or "PowerSecure-owned" model. Our PowerSecure-owned model, while relatively new, represents an increasing portion of our distributed generation business. For distributed generation systems completed under this model, we retain ownership of the distributed generation system after it is installed at the customer's site. Because of this, we invest the capital required to design and build the system, and our revenues are derived from regular fees paid over the life of the recurring revenue contract by the utility or the customer, or both, for access to the system for standby power and peak shaving. The life of these recurring revenue contracts is typically from five to fifteen years. The fees that generate our revenues in the recurring revenue model are generally paid to us on a monthly basis and are set at a level intended to provide us with attractive returns on the capital we invest in installing and maintaining the distributed generation system. Our fees for recurring revenue contracts are generally structured either as a fixed monthly payment, or as a "shared savings recurring revenue contract." For our shared savings recurring revenue contracts, all, or some portion, of our fees are earned out of the pool of peak shaving savings the system generates for the customer.

In both economic models, we believe that the customer value proposition is strong. In the customer-owned model, where the customer pays for and obtains ownership of the system, the customer's typical targeted returns on investment range from 15% to 25%, with a payback targeted at three to five years. These paybacks to the customer result from a combination of the benefits of peak shaving, which creates lower total electricity costs, and the value that the backup power provides in avoiding losses from business interruptions due to power outages. Additionally, utilities gain the benefits of smoother electricity demand curves and lower "peaks", as the result of having reliable standby power supporting customers in their utility systems, power distribution and transmission efficiencies, and of avoiding major capital outlays that would have been required to build centralized power plants and related infrastructure for peaking needs. In our PowerSecure-owned model, where we pay for, install and maintain ownership of the system in exchange for the customer paying us smaller fees over a period of years, utilities and their customers receive access to our system and the related benefits of distributed generation without making a large up-front investment of capital. Under the PowerSecure-owned model, contracts can be structured between us and the utility, us and the customer, or all three parties.

In 2010, 87.7% of our distributed generation revenues consisted of customer-owned sales, and 12.3% of our distributed generation revenues were derived from recurring revenue sales. Sales of customer-owned systems deliver revenues and profits that are recorded on our financial statements over the course of the project and thus are more proximate to the time of the sale and our expenses of that project and generally larger in dollar amount in any particular period than sales of PowerSecure-owned projects, which can cause our consolidated revenues and profits to be more inconsistent from period-to-period as sales fluctuate. By contrast, sales under the PowerSecure-owned system model generate revenues and profits that are more consistent from period-to-period and have higher gross

margins, while at the same time generating revenues and profits over a longer time period although smaller in dollar amount in any particular period, because the revenues and profits are recognized over the life of the contract. Our PowerSecure-owned recurring revenue model also requires us to invest our own capital in the project without any return on capital until after the project is completed, installed and successfully operating.

Our Utility Infrastructure Business

Overview

Our Utility Infrastructure business is focused on helping electric utilities design, build, upgrade and maintain infrastructure that enhances the efficiency of their grid systems. Our products and services include transmission and distribution system construction and maintenance, installation of advanced metering and efficient lighting, and emergency storm restoration. Additionally, we provide utilities with a wide range of engineering and design services, as well as consulting services for regulatory and rate design matters.

Market

There are over 3,000 electric utilities in the U.S. In 2009, it is estimated that these utilities invested over \$20 billion to maintain, upgrade and enhance the efficiency of their transmission and distribution infrastructure. Several industry trends suggest there will be additional growth in transmission and distribution investment over the coming years, including the need to upgrade and replace the utility grid's aging infrastructure to improve and ensure reliability, the expected long-term increase in demand for electric power, and the incorporation of renewable energy and other new power generation sources into the grid. In addition, the trend toward improving the efficiency of our power system overall is driving initiatives and innovations in smart grid technology which will also be a positive driver for overall transmission and distribution system infrastructure spending. The difficult economic cycle of the last several years caused utilities to reduce their spending in these areas, and it is likely that as electricity demand increases with an increase in economic activity, transmission and distribution system infrastructure spending will increase to accommodate increases in demand.

Utilities generally use a combination of internal and third-party outsource vendors to provide construction and maintenance services for their transmission and distribution infrastructure. Utilities also utilize third party engineering and consulting firms to supplement their internal engineering resources. We provide services in each of these areas for investor-owned utilities, referred to as "IOUs", electric cooperatives, and municipal utilities of virtually every size. The primary geography we currently serve is the Southeastern U.S. However, we have grown the geographic base of the utilities we serve over the last several years to include utilities in the Mid-Atlantic, Midwest and Gulf Coast regions. We intend to continue to expand our utility relationships and the geography we serve as our business grows and develops.

Products and Services

In 2005, our Utility Infrastructure strategic growth area commenced its operations through the formation of two businesses, UtilityEngineeringTM and PowerServicesTM, to serve the engineering and consulting needs of our utility clients, and to provide us with capabilities that broadened our overall offerings to our utility partners. The scope of services that we offer through UtilityEngineering includes technical engineering services for our utility partners and their customers, including design and engineering services relating to virtually every element of their transmission and distribution systems, substations and utility lighting. Through PowerServices, we provide management consulting services to utilities and commercial and industrial customers, including planning and quality improvement, technical studies involving reliability analysis and rate analysis, acquisition studies, accident investigations, and power supply contracts and negotiations. Our team of engineers operates out of its principal offices in Raleigh, North Carolina.

Over the last few years, we have continued to enhance our capabilities in the Utility Infrastructure area through our UtilityServicesTM business unit. UtilityServices provides utilities with transmission and distribution construction and maintenance, including substation construction and maintenance, advanced metering and lighting installations, and storm restoration. In addition to providing these services directly to utilities, we also provide services on behalf of utilities for their large business and federal customers. Similar to the products and services we provide for utilities, our work for large utility customers includes turn-key design, procurement and construction services for large transmission and distribution projects, including substations. Our resources include a fleet of owned and leased utility vehicles along with experienced field personnel and engineers, and we also utilize third party resources from time to time, as needed, to supplement our internal resources on particular projects.

Utility Infrastructure services involve the use of equipment and exposure to conditions that can be dangerous. We strive to ensure we are operating safely and prudently, however, from time to time we are subject to claims by employees, customers and third parties for property damage and personal injuries. Our Utility Infrastructure business has comprehensive safety policies, procedures and training programs designed to ensure, to the extent possible, that our operations are conducted in a safe and prudent manner.

Business Model

Revenues for our Utility Engineering and Power Services businesses are earned, billed and recognized based on the number of hours invested in the particular projects and engagements they are serving. Similar to most traditional consulting businesses, these hours are billed at rates that reflect the general technical skill or experience level of the consultant or supervisor providing the services. In some cases, our engineers and consultants are engaged on an on-going basis with utilities, providing resources to supplement utilities' internal engineering teams over long-term time horizons. In other cases, our engineers and consultants are engaged to provide services for very specific projects and assignments.

Revenues for our Utility Services business are generally earned, billed and recognized in two primary models. Under the first model, we have regular, on-going assignments with utilities to provide regular maintenance and upgrade services. These services are earned, billed and recognized either on a fixed fee, based on the number of work units we perform, such as the number of transmission poles we upgrade, or on hourly fees, based on the number of hours we invest in a particular project, plus amounts for the materials we utilize and install. Under the second model, we are engaged to design, build and install large infrastructure projects, including substations, transmission lines, and similar infrastructure, for utilities and their customers. In these types of projects we are generally paid a fixed price for the project, plus any modifications or scope additions. We recognize revenues from these projects on a percentage-of-completion basis as they are completed. In addition to these two primary models, in some cases, we are engaged by utilities and their customers to build or upgrade transmission and distribution infrastructure that we own and maintain. In those cases, we receive fees over a long-term contract in exchange for providing the customer with access to the infrastructure to transmit or receive power.

Our Energy Efficiency Business

Overview

Our Energy Efficiency business is focused on providing energy solutions to utilities, municipalities, and commercial, institutional, and industrial customers that deliver strong returns on investment by reducing energy costs, improving their operations, and benefiting the environment. Our Energy Efficiency area includes our EfficientLights, IES™ and EnergyLite™ businesses and brands. Our EfficientLights business is focused on bringing our EfficientLights branded LED-based lighting products to grocery, drug and convenience stores. These LED lighting products include our largest volume product, our EfficientLights fixture for reach-in refrigerated cases, as well as lighting for walk-in storage coolers and open refrigerated display cases. Additionally, our EfficientLights business is in the process of developing and marketing LED-based parking lot lights and street lights. Our IES business designs and manufactures new LED-based lighting products for commercial, industrial and consumer applications. The business of IES includes turn-key product development, engineering and manufacturing of solid state LED-based lights, including power drivers, light engines and thermal management solutions. IES provides its products directly to OEMs, electronics manufacturers and retailers, either as component solutions or as turn-key products. Additionally, through our EnergyLite business and brand we market our SecureLite™ and PowerLite™ family of area lights and street lights. These products are marketed to utilities and municipalities directly, and through third party distribution arrangements.

Market

The market for LED-based lighting is large and expected to grow rapidly over the next decade. This market growth is driven by the many benefits LED lights provide over traditional lighting, including superior energy efficiency, improved quality of the light emitted, superior heat characteristics, smaller size, relatively low cost over time, and longer life. Because of these factors, LED lighting is also better for the environment than traditional lighting. In 2009, the total demand for white LEDs was approximately \$3 billion, and this amount is expected to grow over 50% in each of the next two years. LED lighting can be utilized in a large range of broad general commercial and industrial lighting applications, as well as used effectively in very specialized applications. In our markets, many of our customers have concluded that LED lighting is the superior choice over traditional lighting,

both for new facility installations and for investments to retrofit existing facilities, due to the financial and environmental benefits and its superior lighting quality. Utilities can also benefit from this technology due to the availability of renewable energy portfolio standard credits for the energy efficiencies our lights deliver, as well as the direct financial and environmental benefits available from investments in LED street lights.

The general LED lighting industry and market is served by companies in the areas of LED chip technology and manufacturing and in LED lighting application development and manufacturing, the area in which we participate and serve. The market for LED-based lighting applications, and the pace at which LED lighting is being and will be adopted, is driven by the return on investment available when an LED-based light is installed instead of or in replacement of traditional lighting. In particular, its size and growth of the LED-based lighting market is driven by the return on investment available to retrofit existing traditional lighting installations with LED-based lighting, given the significant size of the installed base of traditional lighting. To a large extent, this return on investment is influenced and driven by the cost of the LED itself because the LED is the largest single component of cost in the LED lighting application, representing approximately 40% of the cost of the fixture. Over the past two years, the cost of LEDs has decreased significantly, which has been a catalyst driving the growth and expansion in the market for general LED lighting applications. Additionally, LED lighting application and manufacturing companies, such as us, have improved the efficiency and effectiveness of application designs. The combination of these factors has increased the return on investment for LED lighting applications in general, and for LED retrofit opportunities in particular, and we believe these factors will continue to cause the market for LED-based general lighting to continue to grow and expand over the next five to ten years.

Demand for our LED products may also be impacted by changes in government policies, standards or regulations that discourage the use of certain traditional lighting technologies. For example, the Energy Independence and Security Act of 2007 in the United States imposes constraints on the sale of incandescent lights beginning in 2012. However, these regulatory constraints may be eliminated or delayed by legislative action.

Products and Services and Business Model

Our EfficientLights business designs and manufactures LED-based lighting solutions. Today, the primary product in this business is our EfficientLights LED-based light for “reach-in” refrigerated cases of grocery, drug and convenience store chains that improves the quality of light illuminating our customers’ products, and reduces lighting energy costs by approximately 70%. The technology also reduces maintenance expense by extending light life five-fold over traditional lighting, lowering the stores’ carbon footprint, and eliminating the use of traditional, mercury-containing fluorescent lights. We have also introduced two new EfficientLights LED-based lighting products to retailers for refrigerated environments: an overhead light for walk-in storage cases and a shelf light for open refrigerated cases. Additionally, through our EfficientLights business and brand we are in the process of developing LED-based parking lot light and street light applications. We plan to market the LED-based parking lot light to retailers, and street lights to utilities and municipalities, in both cases to help improve the quality and reduce the significant energy and maintenance costs of outdoor overhead lighting. In the future, we plan to develop and market additional LED-based lighting technologies through our EfficientLights business and brand.

We generate revenues in our EfficientLights business through the sale of our proprietary LED lights. These lights are primarily sold as retrofits for existing traditional lighting, although they are also sold for initial lighting installations. From time to time we also provide installation services, although that is not a significant portion of our business. We also assist our customers in receiving utility incentives for LED lighting. Our customers are primarily large retail chains, and their installations of EfficientLights have been across various numerous stores within their store base over a diverse geographic scope. We also sell our LED lights to, and through, original equipment manufacturers, or “OEMs,” of refrigerator and freezer cases. We expect our customer base and sales channels to continue to grow and develop as LED technology continues to be more widely adopted. As we bring additional products to market, including our LED-based parking lot light and street light, we expect to employ a similar business model, although for the street light our customers will likely include utilities and municipalities.

We also generate revenues in our IES business through the sale of proprietary LED lights, as well as the sale of LED-lighting components including power drivers, light engines, and thermal management solutions. Our IES business designs and manufactures these LED-based lighting products for commercial, industrial and consumer applications. IES provides its products directly to OEMs, electronics manufacturers and retailers, either as component solutions or as turn-key products.

Additionally, through our EnergyLite business and brand we market our SecureLite and PowerLite family of area lights and street lights. These products are marketed to utilities and municipalities directly, and through third party distribution arrangements.

Business Structure

On April 30, 2010, through our PowerSecure subsidiary, which previously owned two-thirds of the equity interests in EfficientLights, we exercised our option to purchase the one-third minority interest in EfficientLights in exchange for 1,025,641 shares of our common stock, which had a value of \$11,548,717, based on \$11.26, the last sale price of our common stock on April 30, 2010 as reported on The NASDAQ Global Select Market. The minority interests in EfficientLights were previously owned by the founder, who is the President, of EfficientLights and by five other key employees of EfficientLights. As a result, EfficientLights has become a wholly-owned subsidiary of our PowerSecure subsidiary and there will no longer be a reduction in our consolidated net income due to the net income attributable to the noncontrolling interest.

Our PowerSecure subsidiary owns two-thirds of the membership interests in, and controls the management of, IES. Commencing in 2012, under certain terms and conditions set forth in the governing documents of IES, we have the right to acquire the remaining one-third minority interest in IES currently held by the seller in exchange for shares of our common stock in an amount equal to the value of that minority interest determined under a formula based on the after-tax net income of IES attributable to that minority interest over the four prior quarters multiplied by our consolidated fully diluted price/earnings ratio over the same period, adjusted for non-recurring or extraordinary items, discounted by 30%. If we have reported a net loss for that period, then the minority interest value will be computed based upon the revenues of IES over the four prior quarters multiplied by our consolidated fully diluted price/revenue ratio over the same period, discounted by 30%. Under the applicable formula, in either case, the minimum minority interest value is \$10 million. In the event of a change in control of either us or our PowerSecure subsidiary, then we will be deemed to have automatically exercised our right to acquire the IES minority interest, subject to a minimum minority interest value of \$10 million.

Our Energy Services Business Area and Segment

Until January 2011, our Energy Services business area was operated through our Southern Flow and WaterSecure subsidiaries. We sold 100% of the stock of Southern Flow to a U.S. wholly-owned subsidiary of Zedi for a total purchase price of approximately \$16.5 million in cash, which sale was effective as of January 1, 2011. Southern Flow's results of operations are reported as discontinued operations in our consolidated financial statements.

Southern Flow provides a broad array services to its customers, including on-site field services, chart processing and analysis, laboratory analysis, and data management and reporting. Southern Flow's field services include the installation, testing, calibration, sales and maintenance of measurement equipment and instruments, as well as laboratory analysis of natural gas and natural gas liquids chemical and energy content. As part of its services to its customers, Southern Flow maintains a proprietary database software system which calculates and summarizes energy measurement data for its customers and allows for easy transfer and integration of such data into customers' accounting systems. As an integral part of these services, Southern Flow maintains a comprehensive inventory of natural gas meters and metering parts for resale.

Since the sale of Southern Flow, we conduct our Energy Services operations through our WaterSecure business only. Through WaterSecure, we own approximately 40% of the equity interests of MM 1995-2, an unconsolidated business. The WaterSecure operations own and operate water processing, recycling and disposal facilities in northeastern Colorado, and the business serves oil and natural gas production companies in that area. The WaterSecure operations primarily operate under long-term contracts to process and dispose of water utilized in customers' natural gas production operations. This processing utilizes techniques that are environmentally responsible, and the quality of the services of the WaterSecure operations and the location of its facilities provides it with a strong position in its markets.

Revenue Backlog

For a description of our backlog of orders, see "Item 7. Management's Discussion and Analysis of Financial Condition and Results of Operations--Backlog." Orders in our backlog are subject to delay, deferral or cancellation from time to time by our customers, subject to contractual rights. Given the irregular sales cycle of customer orders,

and especially of large orders, our backlog at any given time is not necessarily an accurate indication of our future revenues.

Customers

Our customers include a wide variety of large and mid-sized commercial and industrial businesses, public and private institutions, and utilities, including investor-owned utilities, cooperatives and municipalities. From time to time, we have derived a significant portion of our revenues from one or more customers, because a significant portion of our revenues can be derived from one or more large projects in any particular period. For example, Publix Super Markets, Inc., was our largest customer from 2006 through 2008, due to large project roll-outs completed during that period, and sales to this customer represented 33% of our consolidated revenues during 2008 and 47% of our consolidated revenues during 2007. However, this customer accounted for only approximately 8% of our consolidated revenues during 2010 and 13% in 2009, because we have completed the installation of those large projects. The customers in our WaterSecure business are primarily oil and natural gas producers in Colorado. Over the past two years, virtually all of our revenues have been generated from customers in the United States.

Sales and Marketing

We market our Energy and Smart Grid Solutions products and services primarily through a direct sales force. Our sales and marketing effort is focused on complementary sales channels that include sales to, and in partnership with, utilities as well as national and local commercial, industrial, institutional and municipal accounts. In our Interactive Distributed Generation business, we are very focused on the needs of utilities, and partner with utilities to develop, market and manage distributed generation systems for their customers. This partnering process includes combining our distributed generation solutions with products or services of the utility, and working with the utility in marketing our distributed generation solution to the end customer. In our Utility Infrastructure business, we market our services directly to utilities, including investor-owned utilities, cooperatives, and municipalities. In our Energy Efficiency business, we market our products to commercial, industrial, and institutional customers, as well as OEM lighting and electronics manufacturers, and also direct to utilities and municipalities. In each of our Energy and Smart Grid Solutions business areas, from time to time we will utilize independent representative networks, and we will also establish alliances with channel partners who can assist with our sales and marketing activities. Our WaterSecure business markets its services through direct sales to oil and natural gas producers in Colorado. We plan to continue expanding our sales and marketing efforts, domestically and globally, in order to market and support our traditional and our new products, services and technologies, including direct sales as well as through third party representative and channel partners.

Competition

We face intense competition in all of our business segments, and business areas.

In our Interactive Distributed Generation business, our competition primarily consists of manufacturers and distributors of power generation and heavy electrical equipment including switchgear, electrical contractors, electrical engineering firms, and companies involved in providing utilities with demand response and load curtailment products and services. Electric utilities could also offer their own distributed generation solutions, which would decrease our base of potential customers. Additionally, several well established companies have developed microturbines used in distributed generation, and a number of companies are also developing alternative generation technology such as wind, fuel cells and solar cells. Several large companies are also becoming leaders in uninterruptible power supply system technology, and companies developing and marketing their proprietary smart grid technologies are also potential competitors. Many of these technologies are eligible for and supported by governmental financial incentives. Additionally, technologies that make commercial, institutional and industrial operations more efficient result in lower electricity use, reducing the benefits of using our distributed generation systems.

In our Energy Efficiency business, we face numerous competitors, particularly in the market for lighting products. Generally, in the lighting market, the less specialized that the technology is, the more competitors are in the space. Accordingly, we focus our efforts in this area on more specialized, proprietary technologies, and we also focus on bringing technologies to customer categories and utilities that we understand best and represent our strongest relationships. However, the LED lighting marketplace is highly fragmented, expanding at a very fast pace, and significant amounts of new competitors are entering the market, including large companies who are strong, sophisticated, have established channel relationship, and are well-capitalized. Additionally, new competitive technologies are being developed, and existing technologies are being improved at a rapid pace. Our LED lighting

products currently face competition from lighting fixture companies, lamp manufacturers and from non-traditional companies focused on LED lighting systems including fixtures and components. Our products compete on the basis of lighting color quality and consistency, light output, energy efficiencies, maintenance savings, light life and return on the customer's investment.

In the Utility Infrastructure area, our UtilityEngineering and PowerServices businesses have numerous competitors, large and small, that offer engineering and design, procurement and construction, and maintenance services to utilities. Also, utilities have their own internal engineering resources that provide alternatives to using our services. Our UtilityServices business also competes with numerous providers of transmission and distribution construction and maintenance firms. Many of these firms have broader customer bases, strong track records of performance, and larger resources of personnel and equipment. Competitors in this area are diverse, consisting of both large and small firms on regional and national levels.

In the Energy Services area, numerous companies provide water processing and disposal, including companies that provide the same services as our WaterSecure operations.

The markets for our products, services and technology are competitive and are characterized by rapidly changing technology, new and emerging products and services, frequent performance improvements, and evolving industry and regulatory standards. We expect the intensity of competition to increase in the future because the growth potential of the energy market has attracted and is anticipated to continue to attract many new competitors, including new businesses as well as established businesses from different industries. As a result of increased competition, we may have to reduce the price of our products and services, and we may experience reduced gross margins, loss of market share or inability to penetrate or develop new markets, or increases in operating expenses or capital investment required to develop and maintain competitive product offerings, any one of which could adversely affect our operating results.

We believe that our ability to compete successfully will depend upon many factors, many of which are outside of our control. These factors include:

- the performance and features functionality and benefits of our, and of our competitors', products and services;
- the value to our customers for the price they pay for our products and services;
- the timing and market acceptance of new products and services and enhancements to existing products and services developed by us and by our competitors, including the effects of environmental initiatives on existing and new technologies and customer preferences;
- our responsiveness to the needs of our customers;
- the ease of use of our, and of our competitors', products and services;
- the quality and reliability of our, and of our competitors', products and services;
- our reputation and the reputation of our competitors;
- our sales and marketing efforts;
- our ability to develop and maintain our strategic relationships; and
- the price of our, and of our competitors', products and services, and the cost to engineer, produce, and deliver our products compared to our competitors, as well as other technological alternatives in the marketplace.

We believe that in many of our markets we have established ourselves as a niche supplier of high quality, reliable products and services and, therefore, compete favorably with respect to the above factors. We do not typically attempt to be the low cost provider. Rather, we endeavor to compete primarily on the basis of the quality of our products and services. In order to be successful in the future, we must continue to respond promptly and effectively to the challenges of technological change and our competitors' innovations. We cannot provide any assurance that our products and services will continue to compete favorably in the future against current and future competitors or that we will be successful in responding to changes in other markets including new products and service and enhancements to existing products and service introduced by our existing competitors or new competitors entering the market.

Many of our existing and potential competitors have better name recognition, longer operating histories, access to larger customer bases and greater financial, technical, marketing, manufacturing and other resources than we do. This may enable our competitors to respond more quickly to new or emerging technologies and changes in customer requirements or preferences and to devote greater resources to the development, promotion and sale of their products and services than we can. Our competitors may be able to undertake more extensive marketing campaigns, adopt more aggressive pricing policies and make more attractive offers to potential employees, customers, strategic partners and suppliers and vendors than we can. Our competitors may develop products and services that are equal or superior to the products and services offered by us or that achieve greater market acceptance than our products do. In addition, current and potential competitors have established or may establish cooperative relationships among themselves or with third parties to improve their ability to address the needs of our existing and prospective customers. As a result, it is possible that new competitors may emerge and rapidly acquire significant market share or impede our ability to acquire market share in new markets. Increased competition could also result in price reductions, reduced gross margins and loss of market share, and the inability to develop new businesses. We cannot provide any assurance that we will have the financial resources, technical expertise, or marketing and support capabilities to successfully compete against these actual and potential competitors in the future. Our inability to compete successfully in any respect or to timely respond to market demands or changes would have a material adverse effect on our business, financial condition and results of operations.

Regulation

Our businesses and operations are affected by various federal, state, local and foreign laws, rules, regulations and authorities. While to date, our compliance with those requirements has not materially adversely affected our business, financial condition or results of operations, we cannot provide any assurance that existing and new laws and regulations will not materially and adversely affect us in the future. In the future, federal, state or local governmental entities or competitors may seek to change existing regulations or impose additional regulations. Any modified or new government regulation applicable to our products or services, whether at the federal, state or local level, may negatively impact the technical specifications, installation, servicing and marketing of our products and increase our costs and the price of our products and services.

Regulation of Electricity. We operate in both regulated and deregulated electricity markets. Rules and regulations within these markets impact how quickly our projects may be completed, could affect the prices we can charge and the margins we can earn, and impact the various ways in which we are permitted or may choose to do business and, accordingly, our assessments of which potential markets to most aggressively pursue. The policies regarding our distributed generation solutions, safety regulations and air quality or emissions regulations, which vary by state, affect how we do business. For example, some state environmental agencies limit the amount of emissions allowed from generators utilized by our customers. In addition, because our distributed generation projects interconnect with the electric power grid, grid interconnection public safety regulations apply. The installation of devices used in our solutions and our generators may be subject to governmental oversight and regulation under state and local ordinances relating to building codes, public safety regulations pertaining to electrical connections and state and local licensing requirements. Moreover, federal, state and local governmental and regulatory authorities may seek to change existing regulations, impose additional regulations or change their interpretation of the applicability of existing regulations. Any new or modified governmental regulations or interpretations thereof that become applicable to our current or future solutions could negatively impact our business and operations, reduce our revenues or increase our costs. We expect the electric utility industry to continue to undergo changes due to the changing and uncertain regulatory environment.

Regulation of Energy and Smart Grid Solutions Operations. Our Energy and Smart Grid Solutions operations are subject to various federal, state, local and international laws and regulations including:

- licensing, permitting and inspection requirements applicable to electricians and engineers;
- building and electrical codes;
- permitting and inspection requirements applicable to construction projects;
- regulations relating to worker safety and environmental protection;
- regulations pertaining to utilities and energy providers; and
- special bidding, procurement and other requirements on government projects.

We believe that we have all the licenses required to conduct our operations and that we are in substantial compliance with applicable regulatory requirements. Our failure to comply with applicable regulations could result

in substantial fines or revocation of our operating licenses.

Regulation of Environment. While various federal, state and local laws and regulations covering the discharge of materials into the environment, or otherwise relating to the protection of the environment, may affect our business, our financial condition and results of operations have not been materially adversely affected by environmental laws and regulations. We believe we are in material compliance with those environmental laws and regulations to which we are subject. We do not anticipate that we will be required in the near future to make material capital expenditures due to these environmental laws and regulations. However, because environmental laws and regulations are frequently changed and expanded, we are unable to provide any assurance that the cost of compliance in the future will not be material to us.

Employees

As of March 1, 2011, we had 390 full-time and 25 part-time employees. None of our employees is covered by a collective bargaining agreement, and we have not experienced any work stoppage. We consider our relations with our employees to be good. Our future success is dependent in substantial part upon our ability to attract, retain and motivate qualified management, technical, marketing and other personnel.

Raw Materials and Component Parts

In our businesses we purchase generators, engines, alternators, electronic components, printed circuit boards, specialized sub-assemblies, relays, electric circuit components, fabricated sheet metal parts, machined components, copper, aluminum, metallic castings, LEDs, other LED lighting materials and components, and various other raw materials, equipment, parts and components for our products and systems from third party vendors and suppliers. While we generally use standard parts and components for our products and systems that are readily available from multiple suppliers, we currently procure, and expect to continue to procure, certain components from single source manufacturers due to unique designs, quality and performance requirements, and favorable pricing arrangements.

While, in the opinion of management, the loss of any one supplier of materials, would not have a material adverse impact on our business or operations due to our belief that suitable and sufficient alternative vendors would be available, from time to time we do encounter difficulties in acquiring certain components due to shortages that periodically arise, supply problems from our suppliers, obsolescence of parts necessary to support older product designs or our inability to develop alternative sources of supply quickly or cost-effectively, and these procurement difficulties could materially impact and delay our ability to manufacture and deliver our products and therefore could adversely affect our business and operations. We attempt to mitigate this risk by maintaining an inventory of such materials. In addition, some of the raw materials used in our business, including but not limited to generators and engines, have significant lead times before they are available, which may affect the timing of our project completions. These delays and lead times can be even longer for parts and materials that we obtain from international sources.

Intellectual Property

Our success and ability to grow depends, in part, upon our ability to develop and protect our proprietary technology and intellectual property rights in order to distinguish our products, services and technology from those of our competitors. We rely primarily on a combination of copyright, trademark and trade secret laws, along with confidentiality agreements, contractual provisions and licensing arrangements, to establish and protect our intellectual property rights. We hold several copyrights, service marks and trademarks in our business, and we have applied for a patent protection and registrations of additional marks, although we may not be successful in obtaining such patent and registering such marks. In the future, we intend to continue to introduce and register new trademarks and service marks, and to file new patent applications, as we deem appropriate or necessary for our business and marketing needs.

Despite our efforts to protect our intellectual property rights, existing laws afford only limited protection, and our actions may be inadequate to protect our rights or to prevent others from claiming violations of their intellectual property rights. Unauthorized third parties may copy, reverse engineer or otherwise use or exploit aspects of our products and services, or otherwise obtain and use information that we regard as proprietary. We cannot assure you that our competitors will not independently develop technology similar or superior to our technology or design around our proprietary technology and intellectual property rights. In addition, the laws of some foreign countries may not protect our intellectual property rights as fully or in the same manner as the laws of the United States.

We do not believe that we are dependent upon any one copyright, trademark, service mark or other intellectual property right. Rather, we believe that, due to the rapid pace of technology and change within the energy industry, the following factors are more important to our ability to successfully compete in our markets:

- the technological and creative skills of our personnel, including our entrepreneurial culture;
- the development of new products, services and technologies;
- frequent product, service and technology enhancements;
- the return on investment that our products and services deliver to our customers;
- name recognition and reputation in the marketplace;
- customer and employee training and development; and
- reliable products and service support.

We cannot assure you that we will be successful in competing on the basis of these or any other factors. See “--Competition” above in this item.

Although we do not believe that our products or technologies infringe on the intellectual property rights of third parties, and we are not aware of any currently pending claims of infringement, we cannot provide any assurance that others will not assert claims of infringement against us in the future or that, if made, such claims will not be successful or will not require us to enter into licensing or royalty arrangements or result in costly and time-consuming litigation.

We may in the future initiate claims or litigation against third parties for infringement of our intellectual property rights to protect these rights or to determine the scope and validity of our intellectual property rights or the intellectual property rights of competitors. These claims could result in costly litigation and the diversion of our technical and management personnel.

Research and Development

Our business leaders and their teams spend a significant amount of time on research and development including management and engineering time, and virtually all of our research and development is performed internally by our personnel. Our research and development activities include developing and enhancing our generator products, controls, switchgear, monitoring and control software, LED lighting products, substation products and designs, microgrid products, and electrical storage technologies, among others. We intend to continue our research and development efforts to enhance our existing products and services and technologies and to develop new products, services and technologies enabling us to enter into new markets and better compete in existing markets. Our future success will depend, in part, upon the success of our research and development efforts.

The markets for our products, services and technology are dynamic, characterized by rapid technological developments, frequent new product introductions and evolving industry standards. The constantly changing nature of these markets and their rapid evolution will require us to continually improve the performance, features and reliability of our products, services and technology, particularly in response to competitive offerings, and to introduce both new and enhanced products, services and technology as quickly as possible and prior to our competitors. We believe our future success will depend, in part, upon our ability to expand and enhance the features of our existing products, services and technology and to develop and introduce new products, services and technology designed to meet changing customer needs on a cost-effective and timely basis. Consequently, failure by us to respond on a timely basis to technological developments, changes in industry standards or customer requirements, or any significant delay in the development or introduction of new products, services and technology, could have a material adverse effect on our business and results of operations. We cannot assure you that we will respond effectively to technological changes or new products, services and technology announcements by others or that we will be able to successfully develop and market new products, services and technology or enhancements.

Business Investments and Acquisitions

From time to time we have made certain business investments and acquisitions to enhance our capabilities and to provide new platforms for growth. Since forming our Interactive Distributed Generation business in 2000, when we formed the first business in our Energy and Smart Grid Solutions segment, we have made the following additional business investments and acquisitions:

- In 2001, we acquired a process control and electric switchgear design and manufacturing firm, which provided the foundation for our NexGear switchgear solutions, an important strategic component of our Interactive Distributed Generation systems.
- In 2005, we launched two new complementary businesses to serve our utility clients by providing regulatory consulting, energy system engineering and design, and energy conservation services. These engineering and consulting capabilities are operated under the brand names UtilityEngineering and PowerServices and constitute the beginning of our Utility Infrastructure business.
- In 2006, we formed a new business to provide energy efficiency services to industrial and commercial customers, primarily involving efficient lighting products. This business operates under the brand name EnergyLite, and now operates under our Energy Efficiency business.
- Also in 2006, we launched a business unit focused on marketing the services of our businesses to federal customers, primarily in conjunction with our utility alliances. This investment represented the next step in the evolution and development of our Utility Infrastructure business, and provided us the capability to do larger-scale power projects for utilities and their federal customers.
- In late 2006, we acquired a business that provides us with the capability to build trailers and enclosures for our distributed generation and switchgear equipment. This business has now been fully incorporated into our Interactive Distributed Generation business primarily as a source of manufacturing for many of the components of our distributed generation systems, including generator technology, and operates as part of our NexGear operation.
- In mid-2007, we launched a business unit focused on providing utilities with solutions involving building and servicing transmission and distribution systems. This business operates under the brand name UtilityServices, and its capabilities further enhance and complement our Utility Infrastructure business, strengthening the breadth of our overall offerings in this area.
- In late 2007, we organized a new business to design and manufacture LED-based lighting solutions, including initially solutions specifically aimed at substantially reducing the energy consumed in grocery, drug, and convenience stores. This business operates under the brand name EfficientLights, and its product offerings include EfficientLights lighting for reach-in refrigerated cases, walk-in refrigerated storage coolers, and shelf lighting for open refrigerated cases. Additionally, we intend to bring LED-based parking lot light and street lights to market in the future through our EfficientLights business.
- In May 2009, we established a new business unit, PowerPackages, LLC, to provide our utility partners with an efficient, dependable, continuous power source for their customers. The new business unit broadens our Interactive Distributed Generation system capabilities by utilizing medium speed engine technology as the system's power source.
- In April 2010, we launched an expansion of our LED lighting business through the formation and acquisition of a two-thirds controlling interest in an LED lighting development company, called IES. This business broadens our Energy Efficiency business unit through the addition of turn-key product development, design and manufacturing of solid state LED-based lights, including power drivers, light engines, and thermal management solutions, as well as a family of street lights under the brand names of SecureLite and PowerLite.

While we regularly engage in discussions relating to potential acquisitions and dispositions of assets, businesses and companies, as of the date of this report we have not entered into any binding agreement or commitment with respect to a material acquisition or disposition that has not been disclosed in this report.

Segment Information

We operate in two market segments:

- In our Energy and Smart Grid Solutions segment, we serve utilities and commercial, institutional and industrial customers through our PowerSecure subsidiary, including the specific areas of Interactive Distributed Generation, Utility Infrastructure and Energy Efficiency.
- In our Energy Services segment, we provide customers in the oil and natural gas production business with our water processing, recycling and disposal services through our WaterSecure business. In this segment we had also provided customers in the oil and natural gas production business with our measurement services and products through our Southern Flow subsidiary, which we sold effective January 1, 2011.

Financial information related to our segment operations for the past three fiscal years is set forth in Note 14, "Segment and Related Information," of the notes to our consolidated financial statements included elsewhere in this report and incorporated herein by this reference.

Discontinued Operations

Pursuant to a purchase agreement dated December 30, 2010, we completed the sale of 100% of the shares of our wholly-owned Southern Flow subsidiary for a total purchase price of approximately \$16.5 million, effective as of January 1, 2011. Accordingly, the operations of Southern Flow are presented as discontinued throughout this report.

Additional Corporate Information

We were incorporated in Delaware on April 5, 1991. On August 22, 2007, we changed our name to PowerSecure International, Inc. from Metretek Technologies, Inc.

Our principal executive offices are located at 1609 Heritage Commerce Court, Wake Forest, North Carolina 27587, and our telephone number at those offices is (919) 556-3056.

Our common stock is listed and traded on The NASDAQ Global Select Market under the symbol "POWR."

Available Information

Our corporate website is located at www.powersecure.com. Information contained on our website is not incorporated into this report, and any references to our website are intended as inactive textual references only. On the investor relations section of our website, we make available, free of charge, our Annual Reports on Form 10-K, Quarterly Reports on Form 10-Q, Current Reports on Form 8-K and amendments to those reports as soon as reasonably practicable after we electronically file them with or furnish them to the SEC. A copy of this Annual Report on Form 10-K is located at the SEC's Public Reference Room at 100 F Street, NE, Washington, D.C. 20549. Information on the operation of the Public Reference Room can be obtained by calling the SEC at 1-800-SEC-0330. The SEC maintains an internet site that contains reports, proxy and information statements and other information regarding our filings at www.sec.gov.

We webcast our earnings calls and certain events we participate in with members of the investment community on our investor relations website. Additionally, we provide notifications of news or announcements regarding our financial performance, including SEC filings, investor events and press and earnings releases as part of our investor relations website. Further corporate governance information, including our corporate governance guidelines, board committee charters and code of conduct, is also available on the investors relations portion of our website. The contents of and the information on or accessible through our corporate website and our investor relations website is not a part of, and is not intended to be incorporated into, this report or any other report or document we file with or furnish to the SEC, and any references to our websites are intended to be an inactive textual references only.

Executive Officers of the Registrant

The names of our executive officers and their ages, positions with us and biographies as of March 1, 2011 are set forth below:

<u>Name</u>	<u>Age</u>	<u>Positions</u>
Sidney Hinton	48	President, Chief Executive Officer and Director
Christopher T. Hutter.....	44	Executive Vice President, Chief Financial Officer and Treasurer
Gary J. Zuiderveen.....	51	Vice President of Financial Reporting, Controller, Principal Accounting Officer, Assistant Treasurer and Secretary

Our executive officers are appointed by, and serve at the discretion of, our board of directors. Each executive officer is a full-time employee. There are no family relationships between any of our executive officers or directors.

Sidney Hinton has served as our President and Chief Executive Officer since April 2007 and has served as a member of our board of directors since June 2007. He has also served as the President and Chief Executive Officer of our PowerSecure subsidiary since its incorporation in September 2000. Mr. Hinton also serves as the Chairman of virtually all of our subsidiaries and as the Chief Executive Officer of certain subsidiaries of our PowerSecure subsidiary. In 2000, he was an Executive-in-Residence with Carousel Capital, a private equity firm. In 1999, he was the Vice President of Market Planning and Research for Carolina Power & Light (now known as Progress Energy). From August 1997 until December 1998, Mr. Hinton was the President and Chief Executive Officer of IllumElex Lighting Company, a national lighting company. From 1982 until 1997, Mr. Hinton was employed in several positions with Southern Company and Georgia Power Company.

Christopher T. Hutter has served as our Vice President, Chief Financial Officer and Treasurer since December 2007 and was appointed as our Executive Vice President in March 2010. Mr. Hutter also serves as Chief Financial Officer of virtually all of our subsidiaries. He was employed in various management positions with ADVO, Inc., a NYSE-listed media and marketing services company located in Hartford, Connecticut, from 1993 until March 2007, when ADVO was acquired by Valassis Communications, Inc. He served as ADVO's National Vice President, Finance, Treasurer, Investor Relations and Assistant Secretary from December 2005 until March 2007, as its Vice President, Financial Planning and Analysis, Investor Relations and Treasurer from November 2003 until December 2005, as its Vice President, Investor Relations and Assistant Treasurer from October 1999 until November 2003, and as its Vice President, Financial Planning and Analysis, Investor Relations and Treasurer from 1998 until 1999. From 1993 through 1998, Mr. Hutter held various financial management positions with ADVO. From 1989 until 1991, Mr. Hutter was employed as a senior staff tax consultant with Deloitte & Touche, an international accounting firm.

Gary J. Zuiderveen has served as our Vice President of Financial Reporting, Controller, Principal Accounting Officer and Secretary since December 2007. Mr. Zuiderveen served as our Vice President and Chief Financial Officer from April 2007 through December 2007, and as our Controller, Principal Accounting Officer and Secretary from April 2001 through April 2007. He had previously served as our Controller from May 1994 until May 2000 and as our Secretary and Principal Accounting Officer from August 1996 until May 2000. He also serves in one or more of the capacities of Controller, Principal Accounting Officer or Secretary of our principal operating subsidiaries. From June 1992 until May 1994, Mr. Zuiderveen was the General Accounting Manager at the University Corporation for Atmospheric Research in Boulder, Colorado. From 1983 until June 1992, Mr. Zuiderveen was employed in the Denver, Colorado office of Deloitte & Touche LLP, providing accounting and auditing services to clients primarily in the manufacturing and financial services industries and serving in the firm's national office accounting research department.

Item 1A. Risk Factors

Our business and future operating results may be affected by many risks, uncertainties and other factors, including those set forth below and those contained elsewhere in this report. If any of the following risks were to occur, our business, affairs, assets, financial condition, results of operations, cash flows and prospects could be materially and adversely affected. When we say that something could have a material adverse effect on us or on our business, we mean that it could have one or more of these effects.

Risks Related to Our Business and Industry

The ongoing economic difficulties, including the challenging business and market conditions and the continuing volatility and disruption in the financial and capital markets, have adversely affected our business and financial results in recent years and could materially and adversely affect our business and financial results in future periods.

The United States and world economies continue to suffer from unfavorable economic conditions, struggling to recover from the economic recession and financial crisis that are still impacting the business community and the financial markets. These economic conditions include uncertainty over the sustainability of economic recovery, ongoing lagging economic activity, volatility in energy prices, decreased consumer confidence, reduced corporate profits and capital spending, adverse business conditions and liquidity concerns in our markets, which have in recent years adversely affected and may in future periods continue to adversely affect our customers and our markets. These poor economic conditions have adversely affected our business and our financial condition and results of operations by extending the length of the sales cycle and causing potential customers to delay, defer or decline to make purchases of our products and services due to uncertainties surrounding the future performance of their businesses, limitations on their capital expenditures, and the adverse effects of the economy and the credit markets on them, especially the business and operating and capital spending budgets of:

- utilities;
- industrial, institutional, commercial, and governmental users of electricity;
- grocery, drug and convenience store retailers; and
- oil and natural gas producers.

While these economic and financial conditions, which have been adversely affecting our business since 2008, have shown signs of improvement, there is no assurance this improvement will continue or that these conditions will not deteriorate further. These conditions make it difficult for our customers, our vendors, and us to accurately forecast and plan future business activities. Our results of operations may be negatively impacted in future periods and we may experience substantial fluctuations from period to period as a consequence of these factors, as such conditions and other factors restricting capital spending may affect the timing of orders from major customers. Until these economic and financial conditions improve sufficiently to allow our customers to gain confidence in a sustained economic recovery, these factors could limit our growth and expansion and otherwise materially and adversely affect our business, financial condition and results of operations.

Our operating results can fluctuate significantly from period to period, which makes our operating results difficult to predict and can cause our operating results to be less than comparable periods and expectations from time to time.

Our operating results have fluctuated significantly from quarter-to-quarter, period-to-period and year-to-year during our operating history and are likely to continue to fluctuate in the future due to a variety of factors, many of which are outside of our control. Factors that affect our operating results include the following:

- the effects of general economic and financial conditions, including the ongoing challenges in the economy and the difficult capital and credit markets, and the potential for such economic and market challenges to continue or recur in the future, negatively impacting our business operations and our revenues and net income, including the negative impact these conditions could have on the timing of and amounts of orders from our customers, and the potential these factors have to negatively impact our access to capital to finance our business;
- the size, timing and terms of sales and orders, including large customer orders, as well as the effects of the timing of project phases of completion, and customers delaying, deferring or canceling purchase orders or making smaller purchases than expected;

- our ability to increase our revenues through long-term recurring revenue projects, recognizing that increasing our revenues from recurring revenue projects will require significant up-front capital expenditures and protract revenue and profit recognition, while increasing our gross margins over the long-term, including our ability to sell, complete and recognize satisfactory levels of quarterly revenues and net income related to our project-based sales and product and service revenues, which are recognized and billed as they are completed, in order to maintain our current profits and cash flow and to satisfy our financial covenants in our credit facilities and to successfully finance the recurring revenue portion of our business model;
- our ability to maintain and grow our utility infrastructure revenues, and maintain and increase pricing, utilization rates and productivity rates, given the significant levels of vehicles, tools and labor in which we have invested and which is required to serve utilities in this business area;
- the sale of our Southern Flow business effective January 1, 2011, and the associated loss of revenues, cash flow and income from that business;
- our ability to obtain adequate supplies of key components and materials of suitable quality for our products on a timely and cost-effective basis, including the impact of potential supply line constraints, substandard parts, and fluctuations in the cost of raw materials and commodity prices, including without limitation with respect to our Energy Efficiency business unit in relation to third party manufacturing arrangements we have with vendors in China;
- the performance of our products, services and technologies, and the ability of our systems to meet the performance standards they are designed and built to deliver to our customers, including but not limited to our recurring revenue projects for which we retain the on-going risks associated with the performance and ownership of the systems;
- our ability to access significant capital resources on a timely basis in order to fund working capital requirements, fulfill large customer orders, and finance capital required for recurring revenue projects and equipment for our utility infrastructure business;
- our ability to implement our business plans and strategies and the timing of such implementation;
- the pace of revenue and profit realization from our new businesses and the development and growth of their markets, including the timing, pricing and market acceptance of our new products and services;
- changes in our pricing policies and those of our competitors, including the introduction of lower cost competing technologies and the potential for them to impact our pricing and our profit margins;
- variations in the length of our sales cycle and in the product and service delivery and construction process;
- changes in the mix of our products and services having differing margins;
- changes in our operating expenses, including prices for materials including but not limited to copper, aluminum and other raw materials, labor costs and other components of our products and services, fuel prices including diesel, natural gas, oil and gasoline, and our ability or inability to hedge or otherwise manage these prices to protect our costs and revenues, minimize the impact of volatile exchange rates and mitigate unforeseen or unanticipated expenses;
- changes in our valuation allowance for our net deferred tax asset, and the resulting impact on our current tax expenses, future tax expenses and balance sheet account balances;
- the effects of severe weather conditions, such as hurricanes, on the business operations of our customers, and the potential effect of such conditions on our results of operations;
- the life cycles of our products and services, and competitive alternatives in the marketplace;
- budgeting cycles of utilities and other industrial, commercial and institutional customers, including impacts of the current downturn in the economy and difficult capital markets conditions on capital projects and other spending items;
- changes and uncertainties in the lead times required to obtain the necessary permits and other governmental and regulatory approvals for projects;
- the development and maintenance of business relationships with strategic partners such as utilities and large customers;
- economic conditions and regulations in the energy industry, especially in the electricity, natural gas

and oil sectors, including the effects of changes in energy prices, electricity pricing and utility tariffs;

- changes in the prices charged by our suppliers;
- the effects of governmental regulations and regulatory changes in our markets;
- the effects of litigation, warranty claims and other claims and proceedings; and
- our ability to make and obtain the expected benefits from the development or acquisition of technology or businesses, and the costs related to such development or acquisitions.

Because we have little or no control over most of these factors, our operating results are difficult to predict. Any substantial adverse change in any of these factors could negatively affect our business and results of operations.

Our revenues and other operating results are heavily dependent upon the size and timing of customer orders and payments, and the timing of the completion of those projects. The timing of large individual orders, and of project completion, is difficult for us to predict. Because our operating expenses are based on anticipated revenues over the long-term and because a high percentage of these are relatively fixed, a shortfall or delay in recognizing revenues can cause our operating results to vary significantly from quarter-to-quarter and can result in significant operating losses or declines in profit margins in any particular quarter. If our revenues fall below our expectations in any particular quarter, we may not be able to or it may not be prudent to reduce our expenses rapidly in response to the shortfall, which can result in us suffering significant operating losses or declines in profit margins in that quarter.

As we develop new lines of business, our revenues and costs will fluctuate because generally new businesses require start-up expenses but take time for revenues to develop. Another factor that could cause material fluctuations in our quarterly results is the amount of recurring, as opposed to project-based, sources of revenue we generate for our distributed generation and utility infrastructure projects. To date, the majority of our Energy and Smart Grid Solutions segment revenues have consisted of project-based distributed generation revenues, project-based utility infrastructure revenues and sales of EfficientLights lighting fixtures, which are recognized as the sales occur or the projects are completed. However, we have marketing efforts focused on developing more sales under our recurring revenue model, for which the costs and capital is invested initially and the related revenue and profit is recognized over the life of the contract, generally five to fifteen years. Recurring revenue projects, compared to project-based sales, are generally more profitable but result in delayed recognition of revenue and net income, especially in the short-term, as we implement an increased number of these recurring revenue projects.

Our Energy Services segment operating results will vary as a result of fluctuations in energy prices. Results from our WaterSecure operations have, in the past, fluctuated significantly with changes in oil and natural gas prices and production in Colorado.

Due to these factors and the other risks discussed in this report, you should not rely on quarter-to-quarter, period-to-period or year-to-year comparisons of our results of operations as an indication of our future performance. Quarterly, period and annual comparisons of our operating results are not necessarily meaningful or indicative of future performance. As a result, it is likely that, from time to time, our results of operations could fall below historical levels or the expectations of public market analysts and investors, which could cause the trading price of our common stock to decline.

We may not be able to remain profitable or return to or exceed the levels of revenues, profits and growth that we have experienced in recent years.

In recent years our operations have generally been profitable and, until 2009, we generally experienced a high rate of growth in our revenues. We may not be able to return to or exceed our historic levels of growth, revenues or profitability in future periods due to the factors listed in this item as well as other factors discussed elsewhere in this report. For example, the difficult economic conditions are negatively affecting our markets and our customers' demand for our products, services and systems. Also, due to sales of our products and services under our recurring revenue model, which model entails significant up-front capital expenditures and costs with the corresponding revenues being realized over an extended number of years, as well as due to costs we incur in connection with the expansion of new businesses, products and services, our revenues and profits may not grow in the future at the same rates as they have grown in the past or could even decline, and we also could incur expenses and capital expenditures in the short-term that could adversely affect our operating results. As a result, there is no assurance that we will continue to generate revenues and profits in future periods that exceed or are comparable to prior periods, or that we will be profitable in any particular future period. If our future growth rates, revenues and

margins do not meet our expectations, or if our operating expenses are higher than we anticipate, then our results of operations could be materially and adversely affected.

The recent sale of our non-core Southern Flow business will reduce our revenues and profits in the near term and could adversely affect our financial results in the longer term, and we could experience similar negative effects to our revenue and profit to the extent that we monetize our other non-core business, our WaterSecure operations.

The recent sale of Southern Flow in 2011 represents a continuation of our strategy to monetize our non-core assets where beneficial in order to focus on our core Energy and Smart Grid Solutions businesses. We received net cash proceeds of approximately \$16.5 million in connection with the sale of Southern Flow. However, we will no longer receive the revenues, positive cash flows and positive earnings generated by that business. In 2010, for example, Southern Flow generated \$19.4 million in revenues, \$2.8 million in operating cash flow, and \$2.5 million in operating income. We intend to deploy the cash proceeds from this sale into core business investments, with the goal of generating even higher revenues, cash flow and operating income from this capital in future periods than we believe our Southern Flow business would have realized. However, there is no assurance that we will be able to find the appropriate business opportunities to invest such cash proceeds, or when those opportunities will arise, or how long it will take them to be financially successful or how successful the financial results of those opportunities will be. Our failure to timely and successfully deploy the capital received from the monetization of our non-core businesses could have a material adverse impact on our financial condition and results of operations.

We may require a substantial amount of additional funds to finance our capital requirements and the growth of our business, and we may not be able to raise a sufficient amount of funds, or to do so on terms favorable to us and our stockholders, or at all.

Although we believe we have adequate liquidity and capital resources to fund our operations internally for the foreseeable future, we may need to obtain additional capital to fund our capital obligations and to finance the growth and expansion of our businesses. For example, we may need substantial capital to finance the development and growth of our recurring revenue projects, which are capital intensive. In addition, our Energy Efficiency and Utility Infrastructure business units have experienced high growth rates, which have required, and will likely continue to require, additional funds to finance working capital needs, and investments in operational equipment. Moreover, from time to time as part of our business plan, we engage in discussions regarding potential acquisitions of businesses and technologies. While our ability to finance future acquisitions could depend on our ability to raise additional capital, as of the date of this report, we have not entered into any agreement committing us to any such acquisition. Moreover, unanticipated events, and events over which we have no control, could increase our operating costs or decrease our ability to generate revenues from product and service sales, necessitating additional capital. We continually evaluate our cash flow requirements as well as our opportunity to raise additional capital in order to improve our financial position. In addition, we continually evaluate opportunities to optimize the availability, cost and terms of our credit facilities. We cannot provide any assurance that we will be able to maintain our existing debt facilities, raise additional capital or replace our current credit facility when needed or desired, or that the terms of any such financing will be favorable to us and our stockholders.

Under our credit facility, which was amended in January 2011 in connection with our sale of Southern Flow and reduced in size in light of the cash proceeds we received, we have a maximum credit line of \$25 million, subject to our meeting certain financial and operating covenants. The credit facility matures on November 12, 2013, but we have the option prior to that maturity date, assuming we are in compliance with all our financial covenants and not otherwise in default, to convert a portion of the outstanding principal balance under that credit facility into a non-revolving term loan for a two year period expiring November 12, 2015, with quarterly payments based upon a four year amortization. However, upon maturity of the credit facility in November 2013, we would still need to refinance any balance of our credit facility that is not so converted, and to obtain funding for our future capital requirements. As of December 31, 2010, we had \$5.0 million of borrowings outstanding under our credit facility, which was the same balance as of March 10, 2011, and we were in full compliance with all our covenants.

Our ability to borrow under the revolving credit facility is subject to our ability to satisfy a number of financial covenants, including a maximum leverage ratio, minimum fixed charge coverage ratio, minimum asset coverage ratio, minimum consolidated tangible net worth, a maximum debt to net worth ratio, and until March 31, 2012 a minimum cash balance equal to 65% of our outstanding credit facility borrowings. Our ability to satisfy those covenants depends principally upon our ability to achieve positive operating performance. If we are unable to fully satisfy the financial covenants of the credit facility, including until March 31, 2012 minimum cash balance equal to 65% of our outstanding credit facility borrowings, and any such failure is not waived by our lenders, then we will be

in breach of the terms of our credit facility. Our obligations under the credit facility are secured by a first priority security interest in substantially all of the assets of our operating subsidiaries, which have guaranteed the credit facility. Any breach of the covenants in the credit facility could result in a default under the credit facility, and lead to an acceleration of the payment of all outstanding debt owed, which could materially and adversely affect our financial condition. In such case, we would seek an amendment, or a waiver of any breach of any term of our credit agreement, or consider other options, such as raising capital through an equity issuance to pay down debt, which could be dilutive to stockholders. There can be no assurance that our lenders would agree to any such amendment or waiver. In the event we obtain such an amendment or waiver under our credit agreement, we would likely incur additional fees and higher interest expense.

Moreover, we could be adversely affected by the failure of one or more of our lenders to fulfill their commitments under our credit facility, due to the recent crisis in the financial markets and banking industry. Our credit facility is provided by a syndicate of several financial institutions, with each institution agreeing severally, and not jointly, to make revolving credit loans to us in accordance with the terms of the credit agreement. If one or more of these financial institutions were to default on its obligation to fund its commitment, the portion of the credit facility provided by such defaulting financial institution would not be available to us.

We may seek to raise any needed or desired additional capital from the proceeds of public or private equity or debt offerings at the holding company level or at the subsidiary level or both, through asset or business sales, from traditional credit financings or from other financing sources. Our ability to obtain additional capital when needed or desired will depend on many factors, including market conditions, our operating performance and investor sentiment, and thus cannot be assured. In addition, depending on how it is structured, raising capital could require the consent of our lenders. Even if we are able to raise additional capital, the terms of any financing could be adverse to the interests of our stockholders. For example, the terms of a debt financing could include covenants that restrict our ability to operate our business or to expand our operations, while the terms of an equity financing, involving the issuance of capital stock or of securities convertible into capital stock, could dilute the percentage ownership interests of our stockholders, and the new capital stock or other new securities could have rights, preferences or privileges senior to those of our current stockholders.

We cannot provide any assurance that sufficient additional funds will be available to us when needed or desired or that, if available, such funds can be obtained on terms favorable to us and our stockholders and acceptable to our lending group, if its consent is required. Our inability to obtain sufficient additional capital on a timely basis on favorable terms could have a material adverse effect on our business, financial condition and results of operations.

Restrictions imposed on us by the terms of our credit facility limit how we conduct our business and our ability to raise additional capital.

The terms of our credit facility contain financial and operating covenants that place restrictions on our activities and limit the discretion of our management. These covenants place significant restrictions on our ability to:

- incur additional indebtedness;
- allow our cash position to fall below certain limits;
- create liens or other encumbrances;
- issue or redeem our securities;
- make dividend payments, stock repurchases and investments;
- incur capital expenditures above certain limits;
- amend our charter documents;
- sell or otherwise dispose of our or our subsidiaries' stock or assets;
- liquidate or dissolve;
- make acquisitions above certain limits; or
- reorganize, recapitalize or engage in a similar business transaction.

Any future financing arrangements will likely contain similar or more restrictive covenants. As a result of these restrictions, we may be:

- limited in how we conduct our business;
- unable to raise additional capital, through debt or equity financings, when needed for our operations and growth; and
- unable to compete effectively, make desired acquisitions or to take advantage of new business opportunities.

The need to comply with the terms of our debt obligations may also limit our ability to obtain additional financing and our flexibility in planning for or reacting to changes in our business. If, as a result of these covenants, we are unable to pursue a favorable transaction or course of action or to respond to an unfavorable event, condition or circumstance, then our business could be materially and adversely affected.

From time to time, a large portion of our revenues and operating results are driven by significant purchase commitments from one or a few customers, and if we do not continue to receive additional significant purchase commitments in the future from those or other customers, our revenues and operating results could be adversely affected.

From time to time, we have certain customers that account for a large portion of our consolidated revenues during a year, and we receive other significant, non-recurring purchase orders from other customers. See “Item 1. Business--Customers” above. For example, from 2006 through 2008, we derived a significant portion of our revenues from one customer, Publix, the revenues from which constituted a range of 33% to 47% of our consolidated revenues during those years. However, by the end of 2008 we had completed the majority of the projects we were awarded by Publix, and in 2009 and 2010 revenues from Publix represented only 13% and 8% of our consolidated revenues, respectively. While we have been diversifying our markets and customer base in order to reduce our dependence on any one or small group of customers in the future, there is no assurance we will be successful in diversifying our business or obtaining additional significant purchase commitments from other customers to replace work that has been completed. If we are unable to obtain additional significant purchase orders in the future and to otherwise diversify and expand our customer base, our revenues and net income in future periods could be adversely affected.

Our success will depend on our continued ability to develop new relationships and to maintain beneficial relationships with our current utility partners and with significant customers and to generate project-based and recurring revenues from those relationships. We cannot provide any assurance that we will be able to attract additional large customer orders in the future to replace revenues from large customer orders in prior years, or that our existing customers will continue to purchase our products and services in future years in the same amounts as in prior years. Our business and operating results would be adversely affected by:

- the loss of one or more large customers;
- any cancellation of orders by, or any reduction or delay in sales to, these customers, including actual customer purchases being less than originally expected when we received the project or sales awards;
- the failure of large purchase commitments to be renewed or to recur;
- delays in timing of future projects with existing and new customers;
- our inability to successfully develop relationships with additional customers; or
- future price concessions that we may have to make to these customers.

We do not have long-term commitments for significant revenues with most of our customers and may be unable to retain existing customers, attract new customers or replace departing customers with new customers that can provide comparable revenues.

Because we generally do not obtain firm, long-term volume purchase commitments from our customers, most of our contracts and commitments from our customers are short-term and project-based, although we are focusing on enhancing our long-term commitments through securing additional recurring revenue projects. As long as the majority of our revenues continue to be recognized on a project by project basis, we remain dependent upon securing new contracts in the future in order to sustain and grow our revenues. Accordingly, there is no assurance that our revenues and business will grow in the future. We cannot provide any assurance that our customers will

continue to use our products and services or that we will be able to replace, in a timely or effective manner, canceled, delayed or reduced orders with new business that generates comparable revenues. Further, we cannot assure you that our current customers will continue to generate consistent amounts of revenues over time. Our failure to maintain and expand our customer relationships could materially and adversely affect our business and results of operations.

Because a significant portion of our backlog consists of non-contractual orders that can be deferred, reduced or cancelled by the customers, our backlog may not be fully recognized or may not result in profits.

A significant portion of our backlog is not comprised of firm, non-cancellable orders. Because a significant portion of the orders in our backlog are not based on contracts, they are subject to delay, deferral, reduction or cancellation from time to time by our customers. Such reductions in backlog could significantly reduce the revenue and profit we actually receive from contracts included in backlog. However, we purchase inventory and equipment, and expend labor resources, on these orders in advance of their delivery and completion, which puts us at risk of incurring expenses against which anticipated revenues may be deferred, reduced or even lost. In the event of a project cancellation, we may be reimbursed for certain costs but typically have no contractual right to the total revenues reflected in our backlog. In addition, projects may remain in backlog for extended periods of time. All of these uncertainties are heightened as a result of negative economic conditions and their impact on our customers' spending. Consequently, we cannot assure you that our estimates of backlog are accurate or that we will be able to realize our estimated backlog. Accordingly, if a significant amount of orders are deferred, reduced or cancelled, our financial condition and results of operations, including our revenues, gross margins, net income and cash flow, could be materially and adversely affected.

The quality and performance of our products are, in part, dependent on the quality of their component parts that we obtain from various suppliers, as well as the specific design and purpose for which the parts are incorporated into our systems, which makes us susceptible to performance issues that arise from time to time that could materially and adversely affect our business, our financial results and our reputation.

From time to time, in the ordinary course of business, we encounter performance issues with component parts that affect the performance of our distributed generation systems, switchgear systems, utility infrastructure products, engines, generators, alternators, breakers, fuel systems, LED and other lighting products, electrical circuit boards, power drivers, and other complex electrical products. While we strive to utilize high quality component parts from reputable suppliers, and to back-up their quality and performance with manufacturers' warranties, even the best parts and components have performance issues from time to time, and these performance issues create significant financial and operating risks to our business, operations and financial results. Because we regularly develop new products and technical designs, we often incorporate component parts into these new products in configurations, for uses, and in environments, for which limited experience exists and that exposes us to performance risks which may not be covered by warranties. As we strive to bring solutions to customers with unique capabilities that provide performance and cost advantages, from time to time we use new suppliers and new products for applications where a track record of performance does not exist or is difficult to ascertain.

Although we believe our suppliers' warranties cover many of these performance issues, from time to time we face disputes with our suppliers with respect to those performance issues and their warranty obligations. Additionally, the outcome of any warranty claims is inherently difficult to predict due to the uncertainty of technical solutions, cost, customer requirements, and the uncertainty inherent in litigation and disputes generally, and thus there is no assurance we will not be adversely affected by these or other performance issues with key parts and components. Moreover, from time to time performance issues are not covered by manufacturer's warranties, certain suppliers may not be financially able to fulfill their warranty obligations, and customers may also claim damages as a result of those performance issues. Also, the mere existence of performance issues, even if finally resolved with our suppliers and customers, can have an adverse effect on our reputation for quality, which could adversely affect our business and financial results.

We estimate that from time to time we have performance issues related to component parts which have a cost basis of approximately 5-20% of our estimated annual revenues, although not necessarily limited to this amount, which are installed in equipment we own and have sold to various customers across our business lines, and additional performance issues could arise in the future. In addition, the failure or inadequate performance of these components pose potential material and adverse effects on our business, operations, reputation and financial results, including reduced revenues for projects in process or future projects, reduced revenues for recurring revenue contracts which are dependent on the performance of the affected equipment, additional expenses and capital cost to repair or replace the affected equipment, inventory write-offs for defective components held in inventory, asset

write-offs for company-owned systems which have been deployed, the cancellation or deferral of contracts by our customers, or claims made by our customers for damages as a result of performance issues.

As of the date of this report, we have experienced performance issues with two types of component parts, in particular, that we are working to resolve. One issue involves a supplier of a substantial distributed generation system component that has indicated its warranty does not cover performance issues related to a component from another supplier that is in many of the distributed generation systems deployed for our customers. Another issue involves generators from a certain supplier that have had performance issues in a distributed generation system we own, and for which we have a performance-based recurring revenue contract that is dependent on the system's positive operating performance. In both of these matters, we are actively working to assess and correct the performance issues, and when possible, we have sought the assistance of the suppliers in resolving these issues.

Given that we are in the process of assessing and addressing these performance issues, the uncertainty regarding the assistance we may or may not receive from our suppliers, our track record of repairing many of these types of issues as well as the inherent uncertainty in addressing technical issues specifically and disputes generally, as of the date of this report we are unable to estimate the potential negative impacts from these particular items, if any, in addition to other component part performance issues discussed above. Thus, there is no assurance that we will not be materially adversely affected by performance issues with key parts and components in our systems that arise from time to time. In addition, at this time we have not recorded any adjustment to our warranty reserve for these particular performance issues, other than an immaterial amount for certain minor repairs, as the estimated cost, if any, of fulfilling our warranty obligations for these performance issues within a possible range of outcomes is not determinable at this time.

Because our future success depends, in part, upon the success of our recurring revenue project business model, which requires us to make up-front investments in capital for distributed generation equipment and utility infrastructure that we will continue to own, and therefore requires us to incur the risks associated with ownership, if we do not receive substantially all of the benefits anticipated by those projects or if one or more of the risks associated with those projects materializes, then our financial condition and results of operations could be materially and adversely affected.

A growing portion of our revenues, cash flow and net income is generated by our recurring revenue projects, in which we install and own distributed generation systems and utility infrastructure and realize recurring revenues derived from regular fees paid by the customer to utilize these assets over a long-term contract, typically five to fifteen years. The revenues from these business arrangements include fixed fee contracts, variable fee contracts, and fees which are dependent on the energy cost reductions realized by our customers. While to date recurring revenue projects have constituted only a modest portion of our revenue base, they are growing significantly, and we expect and intend that they will represent a more significant portion of our revenues in the future. The success of these recurring revenue projects is dependent upon our ability to realize the revenues over the life of the contracts and on our ability to manage the costs of those projects. Accordingly, if we do not realize most of the revenues of these recurring revenue projects, or if the costs to operate or maintain these systems increases significantly, including the cost of fuel, or if one or more material risks related to these projects discussed below materializes, our business and operating results could be materially and adversely affected.

Under these recurring revenue projects, we derive recurring revenues from our customers, which revenue stream enhances the size and dependability of our revenues, cash flow, gross margins and income over the long-term. However, the amount of anticipated recurring revenues and related gross margins and cash flows from these long-term projects are based on a number of assumptions and estimates, including those pertaining to customer demand, energy consumption, energy costs and savings, tariff structures, fuel cost, maintenance cost, our monitoring ability, the quality, reliability and availability of the associated equipment, our capital resources, and the initial and ongoing expenses of the projects. Changes in our estimates or assumptions causing us to fail to realize the benefits of these recurring revenue projects may result in the recurring revenues, gross margins on those revenues and cash flows we receive being substantially less than expected.

Moreover, these recurring revenue projects have certain risks associated with them, in addition to the risks associated with our traditional turn-key distributed generation sales, due to our continued ownership of the underlying equipment and the nature of the relationship we have with the customers under these projects. These risks of engaging in recurring revenue projects include the following:

- disputes arising with the customer about the project that ultimately results in either the customer requiring us, or in us determining, to remove the equipment from the customer's site, which could

result in a significant loss in revenues and cash flow until the equipment can be re-deployed in a new project or, if the equipment is not re-usable, a significant write-down of our assets;

- our inability to receive the intended benefits from the project due to changes associated with the distributed generation model, such as due to changes in tariff structures or customer requirements;
- our inability to receive recurring revenues due to customer issues, such as deterioration in the customer's ability to pay our ongoing fees or a dispute with the customer delaying, deferring or reducing the project fees payable to us, or the closure of the customer's facility;
- the failure of the equipment to properly function and to perform and deliver the intended benefits, which could result in claims by the customer for damages to its equipment, lost revenues and profits or safety issues and in attempts by the customer to cancel the contract related to the project or to refuse or to delay making payments in amounts we believe are due to us under those contracts;
- new regulations, or changes in the interpretation of existing regulations, such as those pertaining to air emissions or those relating to the requirements and conditions for the ownership of power generation systems, that could render our projects no longer economically viable, or technically obsolete, or legally impractical;
- the costs of operating and maintaining the systems increases significantly, including fuel costs, and maintenance expenses;
- damages, payment delays and other issues due to issues with the performance of component parts;
- injuries to persons caused by problems or failures of equipment owned by us; and
- environmental effects, such as fuel spills, requiring costly and time-consuming remediation efforts and potentially subjecting us to fines and penalties related to environmental requirements and regulations.

Accordingly, we cannot provide any assurance that we will realize substantially all the benefits that we expect, or that our business will not face some of the risks, including the risks discussed above, related to these recurring revenue projects, on which we anticipate we will become more dependant in future periods. If we do not receive substantially all of the expected benefits, or if we face one or more significant risks, related to these recurring revenue projects, our financial condition and results of operations could be materially and adversely affected.

We face potential challenges managing our growth to the extent the market continues its strong adoption of LEDs for the general lighting market and for our products in particular.

Our potential for growth depends significantly on the adoption of LEDs within the general lighting market, our ability to positively affect this rate of adoption as it relates to our products, and our ability to successfully manage our potential growth of this business. Although LED lighting has grown rapidly in recent years, adoption of LEDs for general lighting is relatively new, still limited and faces significant challenges before it is adopted on a widespread basis. In order to manage our growth and business strategy effectively, we must continue to:

- invest in adequate manufacturing facilities and equipment to meet customer demand;
- maintain a sufficient supply of raw materials to support our growth; and
- invest in research and development, engineering, sales and marketing, technical support, distribution capabilities and administrative functions.

While we intend to focus on managing our costs and expenses, over the long term we expect to make investments to support our growth and may have additional unexpected costs. Additionally, such investments take time to become fully operational and productive, and we may not be able to expand quickly enough to exploit targeted market opportunities. There are also inherent execution risks in addressing these new market opportunities that could increase costs and reduce our operating results, including design and cost overruns, poor production process yields and reduced quality control during the start-up phase.

The adoption of or changes in government policies, standards or regulations relating to the efficiency, performance or other aspects of LED lighting or changes in government policies, standards or regulations that discourage the use of certain traditional lighting technologies, could impact the demand for our LED products.

The adoption of or changes in government policies, standards or regulations relating the efficiency, performance or other aspects of LED lighting may impact the demand for our LED products. For example, the

Chinese government recently delayed purchases of LED street and tunnel lighting while developing new standards for the required performance for such lighting products in China. The process resulted in reduced short-term demand for those lighting applications.

Demand for our LED products may also be impacted by changes in government policies, standards or regulations that discourage the use of certain traditional lighting technologies. For example, the Energy Independence and Security Act of 2007 in the United States imposes constraints on the sale of incandescent lights beginning in 2012. These constraints may be eliminated or delayed by legislative action, which could have a negative impact on demand for our LED lighting.

If we were to lose the services of one or more of our executive officers, we might not be able to execute our business strategy and our business could be materially and adversely affected.

Our future success depends in large part upon the continued service of our executive officers. In particular, we are dependent upon Sidney Hinton, our President and Chief Executive Officer, who is the visionary and leader of our business and who is critical to the overall management of our company as well as to the development of our business, our future growth and performance and our strategic direction. Although we have entered into employment agreements with our executive officers, we have key man life insurance only on Mr. Hinton, and it might not be in an amount sufficient to offset the adverse effects of the loss of his services to us. The loss of the services of any of our executive officers, especially Mr. Hinton, could materially and adversely affect our business, financial condition and results of operations.

If we are unable to continue to attract and retain key personnel, our business could be materially and adversely affected.

We believe our future success and performance depends, in large part, upon our ability to attract and retain highly qualified leaders for our business units and technical, managerial, sales, marketing, finance and operations personnel. Competition for qualified personnel is intense, and we cannot assure you that we will be able to attract and retain these key employees in the future. The loss of the services of any of our key personnel could have a material adverse effect on our business. Although we have entered into employment agreements with our executive officers and the leaders of some of our business units, we generally do not have employment contracts with our other key employees. In addition, we do not have key person life insurance for most of our key personnel. We cannot assure you that we will be able to retain our current key personnel or that we will be able to attract and retain other highly qualified personnel in the future. We have from time to time in the past experienced, and we expect in the future to continue to experience, difficulty in hiring and retaining highly skilled employees with appropriate qualifications. If we are unable to attract and retain highly qualified personnel, our business could be materially and adversely affected.

Price increases in some of the key components in our products and systems could materially and adversely affect our operating results and cash flows.

The prices of some of the key components of our products and systems are subject to fluctuation due to market forces beyond our control. If we incur price increases from our suppliers for key components in our products and systems or from our contractors, we may not be able to pass all of those price increases on to our customers in the form of higher sales prices, which would adversely affect our operating results and cash flows. For example, most of our revenues in recent years have been generated from fixed price distributed generation projects, and increases in the prices of key components in those projects, such as generators, diesel fuel, copper, aluminum and labor, would increase our operating costs and, accordingly, reduce our margins in those projects. Although we intend to adjust the pricing on future projects based upon long-term changes in the prices of these components, we generally cannot pass on short-term price increases on fixed priced projects, and we may not be able to pass on all long-term price increases. Such price increases could occur from time to time due to spot shortages of commodities or labor, longer-term shortages due to market forces beyond our control or exchange rate fluctuations. An increase in our operating costs due to price increases from these components causing a reduction in our margins could materially and adversely affect our consolidated results of operations and cash flows.

We depend on sole source and limited source suppliers for some of the key components and materials in our products and systems, which makes us susceptible to supply shortages or price increases that could materially and adversely affect our business.

We depend upon sole source and limited source suppliers for some of the key components and materials that we use in our products and systems. If we experience delays in receiving these components or parts, we will not be able to deliver our products and systems to our customers on a timely basis, which could defer revenue and income recognition, cause the cancellation or reduction of some projects and contracts or cause us to incur financial penalties. Also, we cannot guarantee that any of the parts or components that we purchase, if available at all, will be of adequate quality or that the prices we pay for these parts or components will not increase. For example, we are dependent upon obtaining a timely and cost-effective supply of generators for our distributed generation business, but from time to time these generators are in short supply, affecting the timing of our performance and cost of the generators. From time to time we may experience delays in production because the supply of one or more critical components is interrupted or reduced, or because of malfunctions or failures of key components, or we may experience significant increases in the cost of such components. If any of those events occurs and we have failed to identify an alternative vendor, then we may be unable to meet our contractual obligations and customer expectations, which could damage our reputation and result in lost customers and sales, or we may incur higher than expected expenses, either of which could materially and adversely affect our business, operations and results of operations.

Our business is subject to the risk of changes in utility tariff structures, which changes could materially and adversely affect our business as well as our financial condition and results of operations.

Our business is dependent, in part, upon our ability to utilize distributed generation systems to create favorable pricing for customers based on utility tariff structures. If utility tariffs change in some regions, then our business would become less viable in those regions. Moreover, even if such tariffs do not change, if we are unable to obtain the expected benefits from those tariffs, our revenues and income would be materially and adversely affected. Changes in utility tariffs or our inability to obtain the benefits of tariff structures could materially and adversely affect our business, financial condition and results of operations.

Our business is subject to the risk of changes in environmental requirements, which changes could materially and adversely affect our business as well as our financial condition and results of operations.

We presently utilize diesel powered generators in our systems. While these systems can be modified to utilize a blend of natural gas and diesel, and can also utilize biodiesel, diesel is the primary fuel utilized across our fleet of systems. If regulatory requirements in the business regions of our customers are modified to unfavorably affect the utilization of diesel for generation, or require the diesel to have certain properties that impacts the operation of our distributed generation systems or their cost, then our business could be materially and adversely affected. While, in such case, we would utilize our best efforts to find alternative power sources, there is no assurance those alternative sources would be economically acceptable. Thus, unfavorable changes to such regulatory environmental requirements could materially and adversely affect our business as well as our financial condition and results of operations.

In some of our project-based distributed generation system sales, the contracts with our customers have long-term performance requirements that subject us to risks.

In some of our project-based distributed generation system sales, the contracts with our customers have long-term performance requirements that we are responsible for, and these projects subject us to risks due to our obligations under those contracts. For example, in some cases, we are responsible for the full maintenance on the generators and switchgear during the term of the contract, but the reserves we have set aside may not be sufficient to cover our maintenance obligations, and the maintenance package we have purchased designed to cover maintenance on the generators may not be adequate. In addition, changes in circumstances that were not contemplated at the time of the contract could expose us to unanticipated risks or to protracted or costly dispute resolution.

Utility companies or governmental entities could place barriers to our entry into the marketplace that could adversely affect our business.

Utility companies or governmental entities could place barriers on the installation of our products or the interconnection of our distributed generation systems with the electric grid. Further, they could charge additional fees to our customers for installing distributed generation. These types of restrictions, fees or charges could impair

our ability to sell our distributed generation systems, or the ability of our customers to effectively use our systems, or they could increase the costs of operating our systems. This could make our distributed generation systems less desirable, which could materially and adversely affect our business, financial condition and operating results.

We could become subject to burdensome government regulation that affects our ability to offer our products and services or that affects demand for our products and services.

Our business operations are subject to varying degrees of federal, state, local and foreign laws and regulations. For example, our products, services and technologies are subject to government oversight and regulation under federal, state and local ordinances relating to emissions, building codes, public safety regulations pertaining to electrical connections, security protocols and local and state licensing requirements. Regulatory agencies may impose special requirements for the implementation and operation of our products, services or technology that may significantly impact or even eliminate some of our target markets. We may incur material costs or liabilities in complying with government regulations. In addition, potentially significant laws, regulations and requirements may be adopted or imposed in the future. For example, our recurring revenue projects could be materially and adversely affected by new laws or regulations, or new interpretations of existing laws and regulations, that would ban the ownership of power generation by a third party, such as us. Furthermore, some of our customers must comply with numerous laws and regulations.

In February 2009, Congress adopted a stimulus package entitled the American Recovery and Reinvestment Act, commonly referred to as ARRA. ARRA provides funding for various energy projects and directly impacts alternative generation technologies, renewable energy requirements, environmental restrictions and costs and incentives to invest in the electric grid in the United States. While some of the measures, requirements, benefits and funding in this legislation directly and indirectly benefit our business, our customers and our utility partners, other aspects of ARRA benefit our competitors and competitive technologies. Currently, ARRA is not materially impacting our business. However, changes in priorities, spending approvals or beneficiaries of ARRA could impact our business in a more significant manner in the future.

The modification or adoption of future laws and regulations could adversely affect our business, cause us to modify or alter our methods of operations and increase our costs and the price of our products, services and technology. In addition, we cannot provide any assurances that we will be able, for financial or other reasons, to comply with all applicable laws and regulations. If we fail to comply with these laws and regulations, we could become subject to substantial penalties or restrictions that could materially and adversely affect our business.

We may incur liabilities or suffer negative financial or reputational impacts relating to occupational health and safety matters and other accident and safety risks and hazards that are inherent in energy operations.

Portions of our operations are subject to many hazards and risks inherent in the servicing and operation of electrical power lines and production water disposal sites, including encountering unexpected electrical charges, fires, natural disasters, blowouts, cratering and pipeline ruptures. For example, our WaterSecure operations suffered fires in 2008 that resulted in personal injuries, damages to property and the loss of revenues, net income and cash flow due to business interruption, and increased operating expenses due to enhanced safety measures implemented. Additionally, we face risks related to the manufacture, installation, sale, servicing and operation of electrical equipment such as our distributed generation system equipment and utility infrastructure construction, maintenance and service work, including electric shocks and other physical hazards inherent in working with electrical equipment. These hazards and risks could result in personal injuries, loss of life, environmental damage and other damage to our properties and the properties of others and other consequential damages, and could lead to the suspension of certain of our operations, large damage claims, damage to our safety reputation and loss of business.

While we have invested, and will continue to invest, substantial resources in our occupational health and safety programs, our industry involves a high degree of operational risk and there can be no assurance that we will avoid significant liability exposure. Although we have taken what we believe are appropriate precautions, we have suffered accidents in the past and may suffer additional accidents in the future. Serious accidents could result in losses to us as the result of fatalities, personal injuries, damage to property and business interruption, some of which could occur for uninsurable or uninsured risks or could exceed our insurance coverage. In addition, the risks inherent in our business are such that we cannot assure you that we will be able to maintain adequate insurance in the future at reasonable rates. If our safety record were to substantially deteriorate over time or we were to suffer substantial penalties or criminal prosecution for violation of health and safety regulations, our customers could cancel our contracts and not award us future business. Therefore, the occurrence of a significant accident, or other risk event or hazard, that is not fully covered by insurance could materially and adversely affect our business and

financial results, and even if fully covered by insurance could materially and adversely affect our business due to the impact on our reputation for safety.

Because many of our businesses and our product offerings have limited histories and their business strategies are still being developed, their markets may be limited and concentrated, and limited information is available to evaluate their future prospects.

Our business strategy includes the development and expansion of new businesses and product lines from time to time. Examples of recent new product offerings and those in development include our LED-based street lights being developed by our Energy Efficiency business unit, our PowerPackages medium speed engine business that we acquired in 2009, our new SmartStation and micro-grid products, and new engine and generator technologies. Our plans and strategies with respect to these new businesses and product offerings are often based on limited histories and market information and are continually being modified as we seek to maximize their potential. In addition, our new businesses generally have a limited number of customers, and our future success depends in large part upon our ability to expand our customer base and to enhance and develop our products and services in these new businesses so that they will generate significant revenues, profits and cash flow.

As a company developing new businesses in the rapidly evolving energy and technology markets, we face numerous risks and uncertainties that are described in this item as well as other parts of this report. Some of these risks relate to our ability to:

- anticipate, adapt and influence the changing regulatory climate for energy and technology products, services and technology;
- provide new products and services at price points that deliver economic benefits to our customers and to us;
- expand our customer base in our new businesses;
- anticipate and adapt to the changing energy markets and customer preferences;
- attract, retain and motivate qualified personnel and leaders for these new businesses;
- respond to actions taken by our competitors;
- integrate acquired businesses, technologies, products and services;
- generate revenues, gross margins, cash flow and profits from sales of new products and services; and
- implement effective marketing strategies to promote awareness of our new businesses, products and services.

Our business and financial results in the future will depend heavily on the market acceptance and profitability of our new businesses and these new product and service offerings. If we are unsuccessful in addressing these risks or in executing our business strategies, or if our business model fails or is invalid, then our business could be materially and adversely affected.

Changes in our product mix can materially and adversely affect our business.

The margins on our revenues from some of our product and service offerings are higher than the margins on other product and service offerings. For example, the operating margins we obtain on recurring revenue contracts are generally higher than the margins we obtain on project-based sales. Additionally, our margins fluctuate from project to project, depending on the project's scope, technical specifications, and materials and labor costs, among other factors. Our margins can also fluctuate based upon competition, alternative products and services, operating costs, tariff systems and contractual factors. In addition, we cannot currently accurately estimate the margins of some of our new and developing products and services due to their limited operating history. Our new products and services may have lower margins than our current products and services. If in the future we derive a proportionately greater percentage of our revenues from lower margin products and services, then our overall margins on our total revenues will decrease and, accordingly, will result in lower profits and less cash flow on the same amount of revenues.

We are subject to lawsuits, claims and proceedings from time to time, and in the future we could become subject to new proceedings, and if any of those proceedings are material and are successfully prosecuted against us, our business, financial condition and results of operations could be materially and adversely affected.

From time to time, we are involved in a variety of claims, suits, investigations, proceedings and legal actions arising in the ordinary course of our business, including actions with respect to labor and employment, taxes, breach of contract, property damage and other matters. For example, from time to time, we are involved in disputes relating to the scope of our services, or services that we receive from our vendors, and charges or fees relating to those services. These disputes have historically been limited in number and dollar amount and, in the opinion of management, based upon current information, no currently pending or overtly threatened claim is expected to have a material adverse effect on our business, financial condition or results of operations. However, our historical experience is not necessarily indicative of the number or dollar amount of future disputes or claims, and the ultimate outcome of these types of matters cannot be accurately predicted due to the inherent uncertainty of litigation. We have vigorously defended all claims against us in the past, and intend to continue to do so in the future. However, even if we are successful on the merits, any pending or future lawsuits, claims or proceedings could be time-consuming and expensive to defend or settle and could result in the diversion of significant management time and operational resources, which could materially and adversely affect us. In addition, it is possible that an unfavorable resolution of one or more such disputes, claims or proceedings could in the future materially and adversely affect our financial position, results of operations or cash flows.

We extend product warranties which could adversely affect our operating results.

We provide a standard one year warranty for our distributed generation, switchgear, and utility infrastructure equipment and a five year warranty for our LED lighting products. In certain cases, we offer extended warranty terms for those product lines. We reserve for the estimated cost of product warranties when revenue is recognized, and we evaluate our warranty reserves periodically by reviewing our warranty repair experience. While we engage in product quality programs and processes, including monitoring and evaluating the quality of our components suppliers and instituting methods to remotely detect and correct failures, our warranty obligation is affected by actual product failure rates, parts and equipment costs and service labor costs incurred in correcting a product failure. Our warranty reserves may be inadequate due to undetected product defects, unanticipated component failures, or changes in estimates for material, labor and other costs we may incur to replace projected product failures. As a result, if actual product failure rates, parts and equipment costs, or service labor costs exceed our estimates, our operating results could be adversely impacted.

Because we are dependent upon the utility industry for a growing portion of our revenues, reductions or deferrals of purchases of our products and services by utilities or their customers could materially and adversely affect our business.

One of our marketing approaches involves partnering with utilities and selling our products and services to their large commercial, institutional, federal and industrial customers. We have generated a significant portion of our revenues using this approach. However, the purchasing patterns of these customers are cyclical and generally characterized by long budgeting, purchasing and regulatory processes. These customers typically issue requests for quotes and proposals, establish committees to evaluate the purchase proposals, review different technical options with vendors, analyze performance and cost/benefit justifications and perform a regulatory review, in addition to applying budgetary approval processes and operational and financial justifications. In addition, utilities and their customers may defer purchases of our products and services if the utilities reduce capital expenditures as the result of the currently difficult economic and financial market conditions, mergers and acquisitions, pending or unfavorable regulatory decisions, poor revenues due to weather conditions, rising interest rates or general economic downturns, among other factors. These unfavorable conditions could reduce the demand for our products and services and materially and adversely affect our business.

Consolidation in our customer base and utility relationships generates risks that could adversely affect our business.

From time to time industry consolidation can occur and impact our customers and potential customers, as well as our utility relationships and potential utility relationships. Industry consolidation has the potential to impact virtually every area of our business. In each of our businesses, industry consolidation has the potential to create both positive and negative effects on our business. The risks created by industry consolidation include, but are not limited to, instances where our customers or utility company relationships are purchased by other customers or utilities who:

- have vendors other than us from which they prefer to source our products and services;
- seek to reduce the prices they pay for our products and services;
- have not adopted our methodologies and technology;
- impact organizational structures and personnel such that our relationships are negatively affected; or
- in the case of utilities, the consolidation leads to changes in tariff structures that are unfavorable to our business.

Many of our products and services experience long and variable sales cycles, which could have a negative impact on our results of operations for any given quarter or year.

Purchases of our products and services are usually significant financial investments for our customers and are used by our customers to address important and complex business needs. Customers generally consider a wide range of issues before making a decision to purchase our products and services. Before customers commit to purchase our products, they often require a significant technical review, assessment of competitive products and approval at a number of management levels within their organization. Our sales cycle may vary based on the industry in which the potential customer operates and is difficult to predict for any particular transaction. The length and variability of our sales cycle makes it difficult to predict whether particular sales commitments will be received in any given quarter. During the time our customers are evaluating our products and services, we may incur substantial sales and marketing and research and development expenses to customize our products to the customer's needs. We may also expend significant management efforts, increase manufacturing capacity, hire employees, purchase or lease equipment, order long-lead-time components or purchase significant amounts of inventory prior to receiving an order. Even after this evaluation process, a potential customer may not purchase our products. As a result, these long sales cycles may cause us to incur significant expenses without receiving revenue to offset those expenses.

If we are unable to develop new and enhanced products and services that achieve market acceptance in a timely manner, our operating results and competitive position could be harmed.

Our future success will depend on our ability to develop new and enhanced products and services that achieve market acceptance in a timely and cost-effective manner. The markets in which our businesses operate are characterized by frequent introductions of new and enhanced products and services, evolving industry standards and regulatory requirements, government incentives and changes in customer needs. The successful development and market acceptance of our products and services depends on a number of factors, including:

- the changing requirements and preferences of the potential customers in our markets;
- the accurate prediction of market requirements, including regulatory issues;
- the timely completion and introduction of new products and services;
- the quality, price and performance of new products and services;
- the availability, quality, price and performance of competing products, services and technologies;
- our customer service and support capabilities and responsiveness;
- the successful development of our relationships with existing and potential customers; and
- changes in industry standards.

We may experience financial or technical difficulties or limitations that could prevent us from introducing new or enhanced products or services. Furthermore, any of these new or enhanced products and services could contain problems that are discovered after they are introduced. We may need to significantly modify the design of these products and services to correct problems. Rapidly changing industry standards and customer preferences and requirements may impede market acceptance of our products and services. Our business could be materially and adversely affected if we experience difficulties in introducing new or enhanced services and products or if these products and services are not received favorably by our customers.

Development and enhancement of our products and services will require significant additional expenses and could strain our management, financial and operational resources. The lack of market acceptance of our products or services or our inability to generate sufficient revenues from this development or enhancements to offset their costs could have a material adverse effect on our business. In addition, we may experience delays or other problems in

releasing new products and services and enhancements, these delays or problems may cause customers to forego purchases of our products and services to purchase those of our competitors.

We cannot provide assurance that products and services that we have recently developed or that we develop in the future will achieve market acceptance. If our new products and services fail to achieve market acceptance, or if we fail to develop new or enhanced products and services that achieve market acceptance, our growth prospects, operating results and competitive position could be adversely affected.

Rapid technological changes may prevent us from remaining current with our technological resources and maintaining competitive product and service offerings.

The markets in which our businesses operate are characterized by rapid technological change. Significant technological changes could render our existing and planned new products, services and technology obsolete. Our future success will depend, in large part, upon our ability to:

- effectively use and develop leading technologies;
- continue to develop our technical expertise;
- enhance our current products and services with new, improved and competitive technology; and
- respond to technological changes in a cost-effective manner.

If we are unable to successfully respond to technological change or if we do not respond to it in a cost-effective manner, then our business will be materially and adversely affected. We cannot assure you that we will be successful in responding to changing technology. In addition, technologies developed by others may render our products, services and technology uncompetitive or obsolete. Even if we do successfully respond to technological advances, the integration of new technology may require substantial time and expense, and we cannot assure you that we will succeed in adapting our products, services and technology in a timely and cost-effective manner.

Failures in the integrity of our current systems and future system upgrades could materially affect our business performance and our ability to accurately and timely report our financial results.

Our ability to generate accurate and timely financial information for management reporting and public reporting purposes is dependent on the integrity and stability of our current financial systems and upgrades to our systems. This includes our financial and operational systems and underlying processes. Disruptions in our systems integrity could lead to operational issues and inefficiencies in our business which could be material. Our significant growth requires that we upgrade our financial systems from time to time, and we expect financial system upgrades will improve our financial operations when complete, but transitional issues could occur during the upgrade process which could adversely impact our performance as well as the integrity or timing of our financial results.

We face intense competition in the markets for our products, services and technology, and if we cannot successfully compete in those markets, our business could be materially and adversely affected.

The markets for our products, services and technology are intensely competitive and subject to rapidly changing technology, new competing products and services, frequent performance improvements and evolving industry standards. The markets for energy solutions are fragmented. We compete against traditional supply-side resources as well as against solutions offered by utilities and competitive electricity suppliers. We expect the intensity of competition to increase in the future because the growth potential and deregulatory environment of the energy market have attracted and are anticipated to continue to attract many new competitors, including new businesses as well as established businesses from different industries. In addition, the economic downturn has resulted in supply-side imbalances in some of our markets. As a result of increased competition, we may have to reduce the price of our products and services, and we may experience reduced gross margins and loss of market share, which could significantly reduce our future revenues and operating results.

Many of our existing competitors, as well as many potential new competitors, have longer operating histories, greater name recognition, larger customer bases and significantly greater financial, technical, marketing, manufacturing and other resources than we do. This may enable our competitors to respond more quickly to new or emerging technologies and changes in customer requirements or preferences and to devote greater resources to the development, promotion and sale of their products and services than we can. Our competitors may be able to undertake more extensive marketing campaigns, adopt more aggressive pricing policies and make more attractive offers to potential employees, customers, strategic partners and suppliers and vendors than we can. Our competitors

may develop products and services that are equal or superior to the products and services offered by us or that achieve greater market acceptance than our products do. In addition, current and potential competitors have established or may establish cooperative relationships among themselves or with third parties to improve their ability to address the needs of our existing and prospective customers. As a result, it is possible that new competitors may emerge and rapidly acquire significant market share or impede our ability to acquire market share in new markets. We cannot assure you that we will have the financial resources, technical expertise, portfolio of products and services or marketing and support capabilities to compete successfully in the future. Our inability to compete successfully or to timely respond to market demands or changes could have a material adverse effect on our business, conditions and results of operations.

If we fail to effectively manage our operations as we grow, our ability to sell our products and services and to provide quality customer service may be adversely affected.

As our revenues have grown, our business operations and number of employees have grown significantly in recent years to drive and support the growth in our business. Notwithstanding the current negative effects of the recent difficult economic and financial market conditions on our recent operating results, we anticipate our business will grow over the long-term, especially as we expand into new lines of business and new geographic areas. This growth could place a significant strain on our management and operational resources, including our ability to timely and cost-effectively satisfy our customers' demand requirements. We must plan and manage our resources effectively in order to continue to offer quality and successful products and services and to achieve revenue growth and profitability in rapidly evolving markets. If we are not able to effectively manage our long-term growth in the future, our business may be materially and adversely affected.

Our investment in and management of the water processing business held by our WaterSecure operations presents risks to us.

WaterSecure is our subsidiary that manages and holds a significant minority ownership interest in the WaterSecure operations, a private business that owns and operates natural gas production water disposal facilities. While WaterSecure does not intend to form any new businesses of this type, it may from time to time increase its economic interest in this business or initiate or manage actions intended to expand the business's assets or activities. Our investment in and management of this business presents risks to us, including:

- potential material adverse changes in the business, results of operations and financial condition of the WaterSecure operations due to events, conditions and factors outside of our control, such as changes in the price of oil and other general and local conditions affecting the oil and gas market generally, which could reduce the revenues, net income and cash flows of the business and, because we record equity income and receive cash distributions from the business based upon its financial results and available cash, adversely affect our financial results and cash flow;
- potential new market entrants and competition in the oil and natural gas market generally and the specific oil and natural gas market served by our WaterSecure operations in Colorado, which could adversely affect the financial results of the business and, accordingly, our results of operations;
- the hazards of oil production water processing and disposal facilities, including fires, such as the fires that occurred at the facilities in early 2008, that can result in loss of life, personal injuries, damages to facilities that may not be insured, lawsuits by parties that are injured or damaged by those hazards, and the related loss of business, revenues, net income and cash flows;
- environmental contamination and the costs associated with fixing any environmental problems and the risk of damages due to such contamination;
- lawsuits by minority investors in this business who become dissatisfied with its results or other business actions, transactions, or managerial decisions;
- the ability of the business to finance its current and future capital needs;
- changes in the regulatory environment relating to the business;
- reliance upon significant suppliers and customers by the business; and
- changes in technology.

If any of these risks materialize and we are unsuccessful in addressing these risks, our financial condition and results of operations could be materially and adversely affected.

We may be unable to acquire other businesses, technologies or companies or engage in other strategic transactions, or to successfully realize the benefits of any such strategic transactions.

In the past, in addition to organic growth, we have grown by acquiring complimentary products, services, technologies and businesses and entering into other strategic transactions that have enabled us to increase our product and service offerings, expand our markets and add experienced management. As part of our business strategy, we expect to continue to evaluate and consider potential strategic transactions, including business combinations, acquisitions and strategic alliances, to enhance our existing businesses and to develop new products, services. At any given time we may be engaged in discussions or negotiations with respect to one or more of these types of transactions, and any of these transactions could be material to our financial condition and results of operations. However, we do not know if we will be able to identify any future opportunities that we believe will be beneficial for us. Even if we are able to identify an appropriate business opportunity, we may not be able to successfully consummate the transaction, and even if we do consummate such a transaction we may be unable to obtain the benefits or avoid the difficulties and risks of such transaction.

Any future acquisition involves risks commonly encountered in business relationships, including:

- the difficulties in assimilating and integrating the operations, personnel, systems, technologies, products and services of the acquired business;
- the technologies, products or businesses that we acquire may not achieve expected levels of revenue, profitability, benefits or productivity;
- the difficulties in retaining, training, motivating and integrating key personnel;
- the diversion of management's time and resources away from our normal daily operations;
- the difficulties in successfully incorporating licensed or acquired technology and rights into our product and service offerings;
- the difficulties in maintaining uniform standards, controls, procedures and policies within the combined organizations;
- the difficulties in retaining relationships with customers, employees and suppliers of the acquired business;
- the risks of entering markets in which we have no or limited direct prior experience;
- potential disruptions to our ongoing businesses; and
- unexpected costs and unknown risks and liabilities associated with the acquisition.

For these reasons, future acquisitions could materially and adversely affect our existing businesses. Moreover, we cannot predict the accounting treatment of any acquisition, in part because we cannot be certain whether current accounting regulations, conventions or interpretations will prevail in the future. We cannot assure you that we will make any additional acquisitions or that any acquisitions, if made, will be successful, will assist us in the accomplishment of our business strategy, or will generate sufficient revenues to offset the associated costs and other adverse effects or will otherwise result in us receiving the intended benefits of the acquisition. In addition, we cannot assure you that any acquisition of new businesses or technology will lead to the successful development of new or enhanced products and services, or that any new or enhanced products and services, if developed, will achieve market acceptance or prove to be profitable.

If we fail to adequately protect our intellectual property rights, we could lose important proprietary technology, which could materially and adversely affect our business.

Our success and ability to compete depends, in substantial part, upon our ability to develop and protect our proprietary technology and intellectual property rights to distinguish our products, services and technology from those of our competitors. The unauthorized use of our intellectual property rights and proprietary technology by others could materially harm our business. We rely primarily on a combination of copyright, trademark and trade secret laws, along with confidentiality agreements, contractual provisions and licensing arrangements, to establish and protect our intellectual property rights. Although we hold copyrights and trademarks in our business, and we have applied for a patent and the registration of a number of new trademarks and service marks and intend to continue to introduce new trademarks and service marks, we believe that the success of our business depends more upon our proprietary technology, information, processes and know-how than on patents or trademark registrations.

In addition, much of our proprietary information and technology may not be patentable. Also, we may not be successful in obtaining any patents or in registering new marks.

Despite our efforts to protect our intellectual property rights, existing laws afford only limited protection, and our actions may be inadequate to protect our rights or to prevent others from claiming violations of their proprietary rights. Unauthorized third parties may attempt to copy, reverse engineer or otherwise obtain, use or exploit aspects of our products and services, develop similar technology independently, or otherwise obtain and use information that we regard as proprietary. We cannot assure you that our competitors will not independently develop technology similar or superior to our technology or design around our intellectual property. In addition, the laws of some foreign countries may not protect our proprietary rights as fully or in the same manner as the laws of the United States.

We may need to resort to litigation to enforce our intellectual property rights, to protect our trade secrets, and to determine the validity and scope of other companies' proprietary rights in the future. However, litigation could result in significant costs or in the diversion of management and financial resources. We cannot assure you that any such litigation will be successful or that we will prevail over counterclaims against us. Our failure to protect any of our important intellectual property rights or any litigation that we resort to in order to enforce those rights could materially and adversely affect our business.

If we face claims of intellectual property infringement by third parties, we could encounter expensive litigation, be liable for significant damages or incur restrictions on our ability to sell our products and services.

Although we are not aware of any present infringement of our products, services or technology on the intellectual property rights of others, we cannot be certain that our products, services and technologies do not or in the future will not infringe on the valid intellectual property rights held by third parties. In addition, we cannot assure you that third parties will not claim that we have infringed their intellectual property rights.

In recent years, there has been a significant amount of litigation in the United States involving patents and other intellectual property rights. In the future, we may be a party to litigation as a result of an alleged infringement of others' intellectual property. Successful infringement claims against us could result in substantial monetary liability, require us to enter into royalty or licensing arrangements, or otherwise materially disrupt the conduct of our business. In addition, even if we prevail on these claims, this litigation could be time-consuming and expensive to defend or settle, and could result in the diversion of our time and attention and of operational resources, which could materially and adversely affect our business. Any potential intellectual property litigation also could force us to do one or more of the following:

- stop selling, incorporating or using our products and services that use the infringed intellectual property;
- obtain from the owner of the infringed intellectual property right a license to sell or use the relevant technology, which license may not be available on commercially reasonable terms, or at all; or
- redesign the products and services that use the technology.

If we are forced to take any of these actions, our business may be seriously harmed. Although we carry general liability insurance, our insurance may not cover potential claims of this type or may not be adequate to indemnify us for all liability that may be imposed.

Our use of percentage-of-completion accounting could result in a reduction or elimination of previously reported profits.

As discussed in Item 7. "Management's Discussion and Analysis of Financial Condition and Results of Operations — Critical Accounting Policies" and in the notes to our consolidated financial statements included in this report, a significant portion of our revenues is recognized using the percentage-of-completion method of accounting. In applying the percentage-of-completion method to our distributed generation turn-key projects, we have identified the key output project phases that are standard components of these projects. We have further identified, based on past experience, an estimate of the value of each of these output phases based on a combination of costs incurred and the value added to the overall construction project. While the order of these phases varies depending on the project, each of these output phases is necessary to complete each project and each phase is an integral part of the turn-key product solution we deliver to our customers. We use these output phases and percentages to measure our progress toward completion of our construction projects. For each reporting period, the status of each project, by phase, is

determined by employees who are managers of or are otherwise directly involved with the construction project and is reviewed by our accounting personnel. Utilizing this information, we recognize project revenues (and associated project costs) and gross profit based on the percentage associated with output phases that are complete or in process on each of our projects.

In applying the percentage-of-completion method to our utility infrastructure projects, revenues and gross profit are recognized as work is performed based on the relationship between actual costs incurred and total estimated costs at completion. In all cases where we utilize the percentage-of-completion, revenues and gross profit are adjusted prospectively for revisions in estimated total contract costs and contract values. Estimated losses, if any, are recorded when identified.

Because the percentage-of-completion method of accounting relies upon estimates described above, recognized revenues and profits are subject to revision as a project progresses to completion. Revisions in profit estimates are charged to income in the period in which the facts that give rise to the revision become known. In the event we were required to adjust any particular project's estimated revenues or costs, the effect on the current period earnings may be significant. If, however, conditions arise that requires us to adjust our estimated revenues or costs for a series of similar construction projects, the effect on current period earnings would more likely be significant. In addition, certain contracts provide for cancellation provisions prior to completion of a project. The cancellation provisions generally provide for payment of costs incurred, but may result in an adjustment to profit already recognized in a prior period.

When we become unable to use existing net operating loss carryforwards to offset future taxable income for U.S. federal income tax purposes, either because we exhaust them or because we lose the ability to use them for any reason, we would face exposure to significant tax liabilities in the future, adversely affecting our net income and cash flow.

We recorded taxable income since 2005, other than in 2009 when we recorded a taxable loss primarily as a result of utilizing bonus depreciation of current year acquisitions of equipment, and expect to continue to report taxable income in the future. We have been able to offset a substantial amount of our taxable income for U.S. federal income tax purposes by utilizing our net operating loss carryforwards, which we refer to as NOLs, and intend to continue to do so in the future. As of December 31, 2010, our available federal NOLs were approximately \$25.8 million, none of which expire over the next three years. When our aggregate future net income, for federal income tax purposes, exceeds the amount of our available NOLs, we will commence incurring liability for federal income taxes, which will adversely affect our net income, cash flow and available cash resources compared to previous periods during which we were able to utilize our NOLs.

In addition, our ability to utilize these NOLs is subject to significant conditions and restrictions. If we fail to meet these conditions and restrictions, we may be unable to fully utilize some or all of these NOLs. For example, the use of our NOLs is limited under the alternative minimum tax provisions of the U.S. federal income tax, as a result of which we have recorded and paid U.S. federal income taxes in the last three years. Other limitations imposed on our ability to use NOLs to offset future taxable income could cause us to pay U.S. federal income taxes earlier than we otherwise would if such limitations were not in effect, adversely affecting our future net income and cash flow. For example, a corporation that undergoes an "ownership change" for U.S. federal income tax purposes is subject to limitations on its ability to utilize its NOLs to offset future taxable income. A corporation generally undergoes an "ownership change" when the ownership of its stock, by value, changes by more than 50 percentage points over any three year period. Similar rules and limitations may apply for state income tax purposes as well.

We may have tax expense exposure that is greater than anticipated in our estimated tax liabilities.

The determination of our provision for income taxes and other tax liabilities requires estimation and significant judgment, but there are many transactions and calculations where the ultimate tax determination is uncertain. Our determination of our tax liability is always subject to review by applicable taxing authorities, and we are from time to time subject to audits and examinations by the Internal Revenue Service and by state and local tax authorities. Any adverse outcome from these audits or examinations could have a negative effect on our operating results and financial condition. We regularly assess the likelihood of favorable or unfavorable outcomes resulting from these audits and examinations to determine the adequacy of our provision for income taxes. Although we believe our tax estimates are reasonable, the ultimate outcome of any tax audits may differ from the amounts recorded in our financial statements and may materially affect our financial results in the period or periods for which such determination is made.

Changes in our effective tax rate may have an adverse effect on our results of operations.

Our future effective tax rates may be adversely affected by a number of factors including:

- changes in government administrations, such as at the Federal level in the United States, as well as at the state level and in other countries in which we may from time to time operate;
- changes in tax laws or interpretation of such tax laws and changes in generally accepted accounting principles;
- the jurisdiction in which profits are determined to be earned and taxed;
- the resolution of issues arising from tax audits with various authorities;
- changes in the valuation of our deferred tax assets and liabilities;
- adjustments to estimated taxes upon finalization of various tax returns;
- increases in expenses not deductible for tax purposes;
- changes in available tax credits; and
- the recognition and measurement of uncertain tax positions.

Any significant increase in our future effective tax rates could adversely impact net income for future periods. In addition, the determination of our income tax provision requires complex estimations, significant judgments and significant knowledge and experience concerning the applicable tax laws. To the extent our income tax liability materially differs from our income tax provisions and accruals due to factors, including the above, which were not anticipated at the time we estimated our tax provision, our net income or cash flows could be adversely affected.

We are subject to the risks of owning real property.

We own real property, including the land and building constituting our principal executive offices. The ownership of real property subjects us to risks, including:

- the possibility of environmental contamination and the costs associated with fixing any environmental problems and the risk of damages resulting from such contamination;
- adverse changes in the value of the property, due to interest rate changes, changes in the neighborhood in which the property is located, or other factors;
- ongoing maintenance expenses and costs of improvements;
- the possible need for structural improvements in order to complying with zoning, seismic, disability act or other requirements; and
- possible disputes with neighboring owners or others.

Our current and anticipated future international activities subject us to many legal, business, political and economic risks and uncertainties that could adversely affect our operating results if they materialize.

We acquire some of our inventory, primarily for our Energy Efficiency business, and we expect to market and sell some of our products and services, in international markets. While virtually none of our sales have been into international markets in recent years, one component of our strategy for future growth involves the expansion of our products and services into new international markets and the expansion of our marketing efforts in our current international markets. This expansion will require significant management attention and financial resources to establish additional offices, hire additional personnel, localize and market products and services in foreign markets and develop relationships with international service providers. Moreover, we acquire a significant amount of our inventory for our Energy Efficiency business from Asian nations. We have very limited experience in international operations, including developing localized versions of our products and services and developing relationships with international service providers. We cannot provide any assurance that we will be successful in developing international operations, or that revenues from international operations will be sufficient to offset these additional costs. If revenues from international operations are not adequate to offset the additional expense from expanding these international operations, our business could be materially and adversely affected.

International business activities expose us to many of the risks inherent in conducting business on an

international level that could result in increased expenses, or could limit our ability to generate revenues, including:

- difficulties in collecting international accounts receivable and longer collection periods;
- challenges caused by distance, language and cultural differences and by doing business with foreign agencies and governments;
- the impact of local economic conditions and practices;
- difficulties in staffing and managing foreign operations;
- difficulties in complying with foreign regulatory and commercial requirements;
- increased costs associated with maintaining international marketing efforts;
- fluctuations in currency exchange rates;
- potential adverse tax consequences;
- adverse changes in applicable laws and regulatory requirements;
- import and export restrictions;
- export controls relating to technology;
- tariffs, customs and other trade barriers;
- political, social and economic instability;
- reduced protection for intellectual property rights;
- cultural and language difficulties;
- natural disasters and public health emergencies;
- the potential nationalization of businesses;
- shipping costs and delays;
- foreign exchange controls that might prevent us from repatriating foreign earnings or impair our ability to acquire inventory or transfer assets; and
- the localization and translation of products and services.

Our success in expanding our international sales activities will depend in large part on our ability to anticipate and effectively manage these and other risks, many of which are outside of our control. Any of these risks could materially and adversely affect our international operations and, consequently, our operating results. We cannot provide any assurance that we will be able to successfully market, sell and deliver our products and services in foreign markets.

We are subject to physical and financial risks associated with climate change.

We are subject to the risks and uncertainties associated with greenhouse gases, commonly referred to as GHGs, and global climate change. While there is significant controversy and uncertainty over this issue, climate change creates physical and financial risks and uncertainties. Physical risks from climate change could include the risks of an increase in sea level and changes in weather conditions, such as an increase in changes in precipitation and extreme weather events. The possibility of sea level rises could adversely affect our customers in coastal communities. In addition, our potential customers' energy needs vary with weather conditions, primarily temperature and humidity. To the extent weather conditions are affected by climate change, the energy use in our markets could increase or decrease depending on the duration and magnitude of the changes. While the effects of increased energy use could enhance the need for our products and services, decreased energy use due to weather changes could adversely affect our business and financial condition, through decreased revenues. In addition, to the extent climate change impacts a region's economic health, it may also impact our revenues because our financial performance is tied, in part, to the health of the regional economies we serve. To the extent financial markets view climate change and emissions of GHGs as a financial risk, this could negatively affect our ability to access capital markets or cause us to receive less beneficial terms and conditions in future credit financings.

Moreover, the potential economic effects of climate change, such as an increase in energy prices, and the potential effect of future legislation aimed at reducing the impact of climate change and lowering emissions could increase the pace of development of alternative energy sources and supplies, and the voluntary reduction in energy

use, each of which could reduce the need for distributed generation and utility infrastructure services, adversely affecting our business and operating results.

We may be subject to legislative and regulatory responses to climate change, with which compliance could be difficult and costly.

Legislative and regulatory responses related to climate change and new interpretations of existing laws through climate change litigation create financial risk. Increased public awareness and concern has resulted in more federal, state and local requirements to reduce or mitigate the effects of GHGs. Thus, there is a risk that our distributed generation operations, or other businesses could be subject to regulation under climate change laws at the federal, state or local level in the future, and that any such regulation could be difficult and costly to our business and adversely affect our results of operations.

Risks Related to the Ownership of our Shares

Our charter documents, as well as certain portions of Delaware law, contain anti-takeover provisions that could discourage or prevent a third-party acquisition of our common stock, even if an acquisition would be beneficial to our stockholders.

Some provisions in our second restated certificate of incorporation and of our amended and restated by-laws, as well as some provisions of Delaware law, could have the effect of discouraging, delaying or preventing a third party from attempting to acquire us, even if doing so would be beneficial to stockholders, including transactions in which investors might otherwise receive a premium for their shares. These provisions could also limit the price that investors might be willing to pay in the future for shares of our common stock. These provisions could also prevent or frustrate attempts by our stockholders to replace or remove our management. These provisions include:

- a classified board of directors in which only approximately one-third of the total board members are elected at each annual meeting;
- limitations on the ability of stockholders to change the authorized number of directors or to fill vacancies on the board of directors;
- the prohibition of cumulative voting in the election of directors;
- provisions permitting a director to be re-elected in an uncontested election even if less than a majority of the shares voted in that election vote in favor of that director;
- authority for our board of directors to issue shares of our common stock and of our preferred stock, and to determine the price, voting and other rights, preferences, privileges and restrictions of undesignated shares of preferred stock, without any vote by or approval of our stockholders;
- super-majority voting requirements to effect material amendments to our second restated certificate and restated by-laws;
- a limitation on which persons may call a special meeting of stockholders;
- a prohibition on stockholders acting by written consent without a meeting;
- a fair price provision that sets minimum price requirements for potential acquirers under certain conditions;
- anti-greenmail provisions which limit our ability to repurchase shares of common stock from significant stockholders;
- restrictions under Delaware law on mergers and other business combinations between us and any 15% stockholders; and
- advance notice requirements for director nominations and for stockholder proposals.

In addition, we have entered into employment agreements with most of our executive officers which, among other things, include provisions for severance payments and accelerated vesting of benefits, such as accelerated vesting of restricted stock and stock options, upon a change in control or circumstances after a change in control.

Our stockholder rights agreement makes effecting a change of control more difficult, which may discourage offers for shares of our common stock.

Our board of directors has adopted an amended and restated rights agreement, which is intended to maximize the value of our shares in a non-negotiated takeover, control bid or other sale context. However, our rights agreement may have the effect of delaying, deterring, or preventing changes in our management or control of us, which may discourage potential acquirers who otherwise might wish to acquire us at a price deemed inadequate by the board, without the consent of the board of directors. Under the rights plan, if a person or group acquires 15% or more of our common stock, all holders of rights (other than the acquiring stockholder) may, upon payment of the purchase price then in effect, purchase common stock having a value of twice the purchase price. In the event that we are involved in a merger or other similar transaction where we are not the surviving corporation, all holders of rights (other than the acquiring stockholder) shall be entitled, upon payment of the then in effect purchase price, to purchase common stock of the surviving corporation having a value of twice the purchase price. The rights will expire on November 30, 2011, unless we extend the term of the rights agreement or we earlier redeem or exchange the rights.

We have not in the past and we do not currently intend to pay cash dividends on our common stock.

We have never declared or paid any cash dividends on our common stock. We currently intend on retaining any future earnings to fund our operations and growth and do not expect to pay cash dividends in the foreseeable future on the common stock. Future dividends, if any, will be determined by our board of directors, based upon our earnings, financial condition, capital resources, capital requirements, charter restrictions, contractual restrictions and such other factors as our board of directors deems relevant.

The market for our common stock is volatile and subject to extreme trading price and volume fluctuations.

The market price and volume of our common stock has in the past been, and in the future is likely to continue to be, highly volatile. For example, since January 1, 2010, the closing sale price of our common stock has fluctuated from a low of \$6.09 to a high of \$11.68. The stock market in general, and the market for small cap companies and energy companies in particular, have experienced extreme price and volume fluctuations in recent years, and these fluctuations have often been unrelated or disproportionate to the operating performance of those companies. A number of factors could cause wide fluctuations in the market price and trading volume of our common stock to continue in the future, including:

- the effects of economic and market conditions on our business and revenues, especially the effects of the recent financial crisis and economic recession, including the length thereof and the timing of and strength of an economic recovery and its effects on our markets, and the volatility and disruption of the capital and the credit markets on the demand for our products, services and technologies;
- actual or anticipated variations in our results of operations or those of our competitors, or companies that investors consider comparisons to ours;
- announcements by us or our competitors of acquisitions, significant technical innovations, new products or services, product improvements, significant contracts, strategic relationships or capital commitments;
- the receipt, deferral or loss of significant customer orders, including replacing, sustaining and growing revenues from new customers;
- the introduction of new products and services by us or by our competitors;
- the commencement of, or our involvement in, litigation or other legal or regulatory proceedings;
- announcements by us or our competitors about the success or status of business;
- conditions or trends in the energy and technology industries in general, and in the particular markets we serve;
- potential favorable or unfavorable regulatory and legislative impacts, including provisions and spending which may or may not be included in federal economic stimulus legislation;
- changes in revenue or earnings guidance, new business announcements, or our revenue backlog including timing and amounts;
- our financing and capital raising activities;

- recommendations by securities analysts and their revenue and earnings estimates, including changes thereto;
- changes in, or the failure by us to meet, securities analysts' estimates and expectations;
- the lower coverage by securities analysts and the media of smaller issuers like us;
- changes in the market valuation of other energy or technology companies;
- additions or departures of key personnel;
- purchases or sales of our common stock by our directors, executive officers and significant stockholders; and
- general economic, business and market conditions.

Many of these factors are beyond our control. The occurrence of any one or more of these factors could cause the market price of our common stock to increase or decrease significantly, regardless of our operating performance.

In addition, broad fluctuations in price and volume may be unrelated or disproportionate to operating performance. Any significant fluctuations in the future might result in a material decline in the market price of our common stock. In the past, following periods of volatility in the market price of a company's securities, securities class action litigation has often been brought against that company. We may become involved in this type of litigation in the future. Securities litigation is often expensive to defend or settle and could divert management's attention and operational resources, which could have a material adverse effect on our business, even if we ultimately prevail in the litigation.

Item 1B. Unresolved Staff Comments

None

Item 2. Properties

We own our principal executive and operating offices, including the land and building, which are located in Wake Forest, North Carolina. The building consists of approximately 23,000 square feet and sits on approximately 2.65 acres. We also own an 11,770 square foot pre-engineered steel building and land in Randleman, North Carolina that we use for fabrication activities.

We lease four facilities located in Raleigh, Wilmington and Morrisville, North Carolina, which consist of approximately 36,000 square feet in the aggregate. The leases on these facilities have an aggregate monthly rental obligation of approximately \$26,000 and expire at various dates through 2015.

We also lease facilities in McDonough, Georgia, Glen Burnie, Maryland, Ocala, Florida, Anderson, South Carolina (used for our EfficientLights operations), Hitchcock, Texas (used for our PowerPackages business), and in Morrisville and Durham, North Carolina. These facilities consist of approximately 103,000 square feet in the aggregate, and the leases on these facilities have an aggregate monthly rental obligation of approximately \$36,000 and expire at various dates through 2016.

We believe our facilities are suitable and adequate to meet our current needs, although our anticipated growth may require us to obtain additional space in future years. We continually monitor our facilities requirements, and we believe that any additional space needed in the future will be available on commercially reasonable terms.

Item 3. Legal Proceedings

From time to time, we are involved in a variety of claims, lawsuits, investigations, proceedings and other legal actions arising in the ordinary course of our business, including actions with respect to labor and employment, taxes, breach of contract and other matters. We intend to vigorously defend all claims against us. Although the ultimate outcome of these claims cannot be accurately predicted due to the inherent uncertainty of litigation, in the opinion of management, based upon current information, no currently pending or overtly threatened dispute is expected to have a material adverse effect on our business, financial condition or results of operations. However, even if we are successful on the merits, any pending or future lawsuits, claims or proceedings could be time-consuming and expensive to defend or settle and could result in the diversion of management time and operational resources, which could materially and adversely affect us. In addition, it is possible that an unfavorable resolution of one or more such proceedings could in the future materially and adversely affect our financial position, results of operations or cash flows.

Item 4. (Removed and Reserved)

PART II

Item 5. Market for Registrant's Common Equity, Related Stockholder Matters and Issuer Purchases of Equity Securities

Market Information

Our common stock has been listed and traded on The NASDAQ Global Select Market under the symbol "POWR" since August 22, 2007. From August 10, 2005 through August 21, 2007, our common stock was listed and traded on the American Stock Exchange under the symbol "MEK". From October 15, 2002 through August 9, 2005, our common stock was traded over-the-counter on the OTC Bulletin Board under the symbol "MTEK".

The following table sets forth the range of the high and low sales prices per share of our common stock, as reported on The NASDAQ Global Select Market for the periods indicated.

	<u>High</u>	<u>Low</u>
<u>Fiscal Year 2010 Quarters Ended:</u>		
March 31.....	\$ 8.58	\$ 6.09
June 30.....	11.68	7.72
September 30.....	11.02	8.26
December 31.....	9.90	7.45
<u>Fiscal Year 2009 Quarters Ended:</u>		
March 31.....	\$ 4.72	\$ 3.27
June 30.....	4.96	3.46
September 30.....	6.91	4.43
December 31.....	10.17	6.70

On March 1, 2011, the last sale price of our common stock as reported on The NASDAQ Global Select Market was \$7.31.

Holders

As of March 1, 2011, there were 116 holders of record of our common stock. Such number of record holders does not include additional individuals and institutions whose shares are held in street name by banks, brokerage firms and other institutions on their behalf.

Dividends

We have never declared or paid any cash dividends on our common stock, and we do not anticipate declaring or paying any cash dividends on our common stock in the foreseeable future. We currently intend to retain future earnings, if any, for investment in the development, operation and growth of our business and for the servicing and repayment of indebtedness. Future cash dividends, if any, will be determined by our board of directors, in its discretion, based upon our earnings, financial condition, capital resources, capital requirements, charter restrictions, contractual restrictions, including those under our credit arrangements, and such other factors as our board of directors deems relevant.

Item 6. Selected Financial Data

The following selected consolidated financial data has been derived from our audited consolidated financial statements. This information is not necessarily indicative of results to be expected from our future operations, and should be read in conjunction with our audited consolidated financial statements and the notes thereto and with "Item 7. Management's Discussion and Analysis of Financial Condition and Results of Operations" included in this report.

Consolidated Statement of Operations Data:	Year Ended December 31,				
	2010	2009	2008	2007	2006
	(In thousands, except per-share amounts)				
Revenues	\$ 97,514	\$ 85,426	\$ 115,993	\$ 94,923	\$ 99,543
Cost of sales	62,220	54,231	77,550	65,015	72,318
Gross profit	<u>35,294</u>	<u>31,195</u>	<u>38,443</u>	<u>29,908</u>	<u>27,225</u>
Operating expenses:					
General and administrative	29,339	24,169	27,128	21,086	17,612
Selling, marketing and service	5,154	3,927	5,325	3,539	2,848
Depreciation and amortization	2,754	2,144	1,847	1,355	764
Restructuring charges	-	-	-	14,139	-
Total operating expenses	<u>37,247</u>	<u>30,240</u>	<u>34,300</u>	<u>40,119</u>	<u>21,224</u>
Operating income (loss)	(1,953)	955	4,143	(10,211)	6,001
Other income and (expenses):					
Equity income	3,182	2,167	3,490	2,774	2,221
Management fees	583	447	556	423	365
Interest income and other income	99	161	464	1,131	1,036
Interest expense	(619)	(607)	(287)	(51)	(130)
Income (loss) before income taxes	1,292	3,123	8,366	(5,934)	9,493
Income tax benefit (provision)	(526)	(331)	(729)	2,256	(175)
Income (loss) from continuing operations	766	2,792	7,637	(3,678)	9,318
Income from discontinued operations (1)	2,543	1,513	3,021	2,040	2,459
Net income (loss)	3,309	4,305	10,658	(1,638)	11,777
Less: Net income attributable to noncontrolling interest	153	(1,512)	-	30	(72)
Net income (loss) attributable to PowerSecure International, Inc.	<u>\$ 3,462</u>	<u>\$ 2,793</u>	<u>\$ 10,658</u>	<u>\$ (1,608)</u>	<u>\$ 11,705</u>
Basic earnings (loss) per share:					
Income (loss) from continuing operations	\$ 0.05	\$ 0.07	\$ 0.45	\$ (0.23)	\$ 0.62
Income from discontinued operations	0.14	0.09	0.18	0.13	0.16
Net income (loss)	<u>\$ 0.19</u>	<u>\$ 0.16</u>	<u>\$ 0.63</u>	<u>\$ (0.10)</u>	<u>\$ 0.78</u>
Diluted earnings (loss) per share:					
Income (loss) from continuing operations	\$ 0.05	\$ 0.07	\$ 0.44	\$ (0.23)	\$ 0.56
Income from discontinued operations	0.14	0.09	0.18	0.13	0.15
Net income (loss)	<u>\$ 0.19</u>	<u>\$ 0.16</u>	<u>\$ 0.62</u>	<u>\$ (0.10)</u>	<u>\$ 0.71</u>
Weighted average common shares outstanding:					
Basic (2)	18,133	17,177	16,978	16,148	15,063
Diluted	<u>18,603</u>	<u>17,343</u>	<u>17,284</u>	<u>16,148</u>	<u>16,477</u>
Amounts attributable to PowerSecure International, Inc. common stockholders:					
Income (loss) from continuing operations	\$ 919	\$ 1,280	\$ 7,637	\$ (3,648)	\$ 9,246
Discontinued operations	2,543	1,513	3,021	2,040	2,459
Net income (loss)	<u>\$ 3,462</u>	<u>\$ 2,793</u>	<u>\$ 10,658</u>	<u>\$ (1,608)</u>	<u>\$ 11,705</u>

(1) During fiscal 2010, our board of directors approved a plan to sell our Southern Flow business and all of its assets and operations were sold effective January 1, 2011. During fiscal 2007, our board of directors

approved a plan to discontinue the business of our Metrotek Florida operation and substantially all of its assets and operations were sold in March, 2008. The operations of Southern Flow and Metrotek Florida have been classified as discontinued operations for all periods presented. In addition, certain other amounts prior to fiscal 2010 have been reclassified to conform to fiscal 2010 presentation. Such reclassifications had no impact on our net income (loss) or stockholders' equity.

- (2) Basic shares outstanding for all periods presented include unvested restricted stock awards that contain non-forfeitable rights to dividends on a basis equal to our other common stockholders.

Consolidated Balance Sheet Data:	December 31,				
	2010	2009	2008	2007	2006
	(In thousands)				
Cash and cash equivalents	\$ 8,202	\$ 20,169	\$ 24,316	\$ 28,710	\$ 15,916
Working capital	54,514	47,221	42,554	41,278	38,988
Total assets	120,529	111,477	110,834	113,023	89,699
Long-term capital lease obligations	3,647	4,445	5,201	5	-
Revolving line of credit and long-term debt	5,000	-	-	-	-
Total stockholders' equity	87,244	79,239	72,811	59,240	58,000

Item 7. Management's Discussion and Analysis of Financial Condition and Results of Operations

The discussion in this item, as well as in other items in this report, contains forward-looking statements within the meaning of and made under the safe harbor provisions of Section 27A of the Securities Act and Section 21E of the Exchange Act. Forward-looking statements are all statements other than statements of historical facts, including statements that refer to plans, intentions, objectives, goals, strategies, hopes, beliefs, projections and expectations or other characterizations of future events or performance, and assumptions underlying the foregoing. See "Cautionary Note Regarding Forward-Looking Statements" at the beginning of this report. Forward-looking statements are not guarantees of future performance or events, but are subject to and qualified by known and unknown risks, uncertainties and other factors that could cause actual results to differ materially from those expressed, anticipated or implied by such forward-looking statements, including those risks, uncertainties and other factors described above in "Item 1A. Risk Factors," as well as other risks, uncertainties and factors discussed elsewhere in this report, in documents that we include as exhibits to or incorporate by reference in this report, and in other reports and documents that we from time to time file with or furnish to the SEC. You are cautioned not to place undue reliance on any forward-looking statements, any of which could turn out to be materially wrong. Any forward-looking statements made in this report speak only as of the date of this report. We undertake no duty or obligation to update or revise any forward-looking statement or to publicly disclose any update or revision for any reason, whether as a result of changes in our expectations or the underlying assumptions, the receipt of new information, the occurrence of future or unanticipated events, circumstances or conditions or otherwise.

The following discussion and analysis of our consolidated results of operations for the years ended December 31, 2010, 2009 and 2008, and of our consolidated financial condition as of December 31, 2010 and 2009 should be read in conjunction with our consolidated financial statements and related notes included elsewhere in this report.

Overview

Our strategy is to provide energy-related products and services that generate strong returns on investment for electric utilities and their commercial, institutional and industrial customers. We provide these products and services through our Energy and Smart Grid Solutions segment in three strategic business areas: Interactive Distributed Generation, Utility Infrastructure, and Energy Efficiency. We are continually listening to existing and potential utility partners, customers, and potential customers, to identify energy-related products and services we can deliver to add value to their businesses. We seek to fill these needs in several ways, including:

- from our existing portfolio of products and services that have demonstrated their value in similar or complementary situations, usually customizing them for each particular application,
- from new energy-related technologies and capabilities which are emerging or being developed by third parties, that we can either incorporate into our existing product lines or bring to market as a new product offering, and
- by developing new technologies and capabilities internally to serve existing and potential customers when options do not exist in the marketplace that meet our quality, effectiveness, cost, and financial return standards.

Over the near and mid-term, we expect these business development efforts, and our resources, will primarily be focused on growing our business in our Energy and Smart Grid solutions segment, which is comprised of our Interactive Distributed Generation, Utility Infrastructure, and Energy Efficiency businesses, and which is our primary focus for growth. Over the longer term, we expect to identify additional areas of business expansion that are complementary to these three businesses.

We conduct non-core business through our Energy Services segment. This segment, which since January 2011 has been comprised solely of our WaterSecure business, serves customers in the oil and natural gas production business with water processing, recycling and disposal services. We do not anticipate making additional significant investments in this business, other than select high-return opportunities that can be funded using the cash flow generated by the business itself.

Interactive Distributed Generation

Our Interactive Distributed Generation business involves manufacturing, installing, and operating electric generation systems "on site" at the facility where the power is used, including commercial, institutional, and industrial operations, generally on behalf of electric utilities. Our systems provide a dependable backup power

supply during power outages, and provide a more efficient and environmentally friendly source of power during high cost periods of peak power demand.

Our Interactive Distributed Generation systems are sold to customers utilizing two basic economic models, each of which can vary depending on the specific customer and application. In our original business model, which is still our primary model, we sell the distributed generation system to the customer. We refer to this as a "project-based" or a "customer-owned" model. For distributed generation systems sold under the project-based model, the customer acquires ownership of the distributed generation assets upon our completion of the project. Our revenues and profits from the sale of systems under this model are recognized over the period during which the system is installed. In the project-based model, we will also usually receive a modest amount of on-going monthly revenue to monitor the system for backup power and peak shaving purposes, as well as to maintain the system.

Our second business model is structured to generate long-term recurring revenues, which we refer to as our "recurring revenue model" or our "PowerSecure-owned" model. Our PowerSecure-owned model, while relatively new, represents an increasing portion of our distributed generation business. For distributed generation systems completed under this model, we retain ownership of the distributed generation system after it is installed at the customer's site. Because of this, we invest the capital required to design and build the system, and our revenues are derived from regular fees paid over the life of the recurring revenue contract by the utility or the customer, or both, for access to the system for standby power and peak shaving. The life of these recurring revenue contracts is typically from five to fifteen years. The fees that generate our revenues in the recurring revenue model are generally paid to us on a monthly basis and are set at a level intended to provide us with attractive returns on the capital we invest in installing and maintaining the distributed generation system. Our fees for recurring revenue contracts are generally structured either as a fixed monthly payment, or as a "shared savings recurring revenue contract". For our shared savings recurring revenue contracts, all, or some portion, of our fees are earned out of the pool of peak shaving savings the system generates for the customer.

In our PowerSecure-owned model, where we pay for, install and maintain ownership of the system in exchange for the customer paying us smaller fees over a period of years, utilities and their customers receive access to our system and the related benefits of distributed generation without making a large up-front investment of capital. Under the PowerSecure-owned model, contracts can be structured between us and the utility, us and the customer, or all three parties.

In 2010, 87.7% of our distributed generation revenues consisted of customer-owned sales, and 12.3% of our distributed generation revenues were derived from recurring revenue sales. Sales of customer-owned systems deliver revenues and profits that are recorded on our financial statements over the course of the project and thus are more proximate to the time of the sale and our expenses of that project and generally larger in dollar amount in any particular period than sales of PowerSecure-owned projects, which can cause our consolidated revenues and profits to be more inconsistent from period-to-period as sales fluctuate. By contrast, sales under the PowerSecure-owned system model generate revenues and profits that are more consistent from period-to-period and have higher gross margins, while at the same time generating revenues and profits over a longer time period although smaller in dollar amount in any particular period, because the revenues and profits are recognized over the life of the contract. The PowerSecure-owned recurring revenue model also requires us to invest our own capital in the project without any return on capital until after the project is completed, installed and successfully operating.

Utility Infrastructure

Our Utility Infrastructure business is focused on helping electric utilities design, build, upgrade, and maintain infrastructure that enhances the efficiency of their grid systems. Through our UtilityServices business, we provide transmission and distribution system construction and maintenance products and services, install advanced metering and efficient lighting, and provide emergency storm restoration services. Additionally, through our UtilityEngineering and PowerServices consulting engineering firms, we provide utilities with a wide range of engineering and design services, as well as consulting services for regulatory and rate design matters.

Revenues for our UtilityEngineering and PowerServices businesses are earned, billed, and recognized based on the number of hours invested in the particular projects and engagements they are serving. Similar to most traditional consulting businesses, these hours are billed at rates that reflect the general technical skill or experience level of the consultant or supervisor providing the services. In some cases, our engineers and consultants are engaged on an on-going basis with utilities, providing resources to supplement utilities' internal engineering teams over long-term time horizons. In other cases, our engineers and consultants are engaged to provide services for very specific projects and assignments.

Revenues for our UtilityServices business are generally earned, billed, and recognized in two primary models. Under the first model, we have regular, on-going assignments with utilities to provide regular maintenance and upgrade services. These services are earned, billed, and recognized either on a fixed fee basis, based on the number of work units we perform, such as the number of transmission poles we upgrade, or on an hourly fee basis, based on the number of hours we invest in a particular project, plus amounts for the materials we utilize and install. Under the second model, we are engaged to design, build and install large infrastructure projects, including substations, transmission lines, and similar infrastructure, for utilities and their customers. In these types of projects we are generally paid a fixed price for the project, plus any modifications or scope additions. We recognize revenues from these projects on a percentage-of-completion basis as they are completed. In addition to these two primary models, in some cases, we are engaged by utilities and their customers to build or upgrade transmission and distribution infrastructure that we own and maintain. In those cases, we receive fees over a long-term contract for the customer to have access to the infrastructure to transmit or receive power.

Energy Efficiency

Our Energy Efficiency business is focused on providing energy solutions to utilities, municipalities, and commercial, institutional, and industrial customers that deliver strong returns on investment by reducing energy costs, improving their operations, and benefiting the environment. Our Energy Efficiency area includes our EfficientLights, IES and EnergyLite businesses and brands. Our EfficientLights business is focused on bringing our EfficientLights branded LED-based lighting products to grocery, drug, and convenience stores. These LED lighting products include our largest volume product, our EfficientLights fixture for reach-in refrigerated cases, as well as lighting for walk-in storage coolers and open refrigerated display cases. Additionally, our EfficientLights business is in the process of developing and marketing LED-based parking lot lights and street lights. Our IES business designs and manufactures new LED-based lighting products for commercial, industrial and consumer applications. The business of IES includes turn-key product development, engineering, and manufacturing of solid state LED-based lights, including power drivers, light engines, and thermal management solutions. IES provides its products directly to OEMs, electronics manufacturers, and retailers, either as component solutions or as turn-key products.

We generate revenues in our EfficientLights business through the sale of our proprietary LED lights. These lights are primarily sold as retrofits for existing traditional lighting, although they are also sold for initial lighting installations. From time to time we also provide installation services, although that is not a significant portion of our business. We also assist our customers in receiving utility incentives for LED lighting. Our customers are primarily large retail chains, and their installations of EfficientLights have been across various numerous stores within their store base over a diverse geographic scope. We also sell our LED lights to, and through, original equipment manufacturers, or "OEMs," of refrigerator and freezer cases. We expect our customer base and sales channels to continue to grow and develop as LED technology continues to be more widely adopted. As we bring additional products to market, including our LED-based parking lot light and street light, we expect to employ a similar business model, although for the street light our customers will likely include utilities and municipalities.

We also generate revenues in our IES business through the sale of proprietary LED lights, as well as the sale of LED-lighting components including power drivers, light engines, and thermal management solutions. Our IES business designs and manufactures these LED-based lighting products for commercial, industrial and consumer applications. IES provides its products directly to OEMs, electronics manufacturers, and retailers, either as component solutions or as turn-key products. Additionally, IES's turn-key products are distributed through our EnergyLite business and brand, including our SecureLite and PowerLite family of area lights and street lights. We expect our IES business to bring additional LED lighting products and components to market, and employ a similar business and distribution model.

Additionally, through our EnergyLite business and brand we market our SecureLite and PowerLite family of area lights and street lights. These products are marketed to utilities and municipalities directly, and through third party distribution arrangements.

Energy Services Business

We currently conduct our Energy Services operations through our WaterSecure business. Through WaterSecure, we own approximately 40% of the equity interests of MM 1995-2, an unconsolidated business. Equity income at our Energy Services segment consists of our minority ownership interest in the earnings of the WaterSecure operations. Our equity income is a direct function of the net income of the WaterSecure operations as well as changes in our ownership interest. The WaterSecure operations own and operate water processing, recycling, and disposal facilities in northeastern Colorado, and the business serves oil and natural gas production

companies in that area. The WaterSecure operations primarily operate under long term contracts to process and dispose of water utilized in customers' natural gas production operations. This processing utilizes techniques that are environmentally responsible, and the quality of the services of the WaterSecure operations and the location of its facilities provides it with a strong position in its markets.

Our Energy Services operations previously included Southern Flow, which we sold effective January 1, 2011 pursuant to a purchase and sale agreement we entered into with the purchaser on December 30, 2010. Southern Flow provides a variety of oil and natural gas measurement services principally to customers involved in the business of oil and natural gas production, gathering, transportation and processing, with a focus on the natural gas market. As a result of the sale of Southern Flow, its results of operations are now reflected as discontinued operations in our consolidated statements of operations for all periods presented in this report.

How We Evaluate our Business Performance and Opportunities

Major Qualitative and Quantitative Factors we Consider in the Evaluation of Our Business

The major qualitative and quantitative factors we consider in the evaluation of our operating results, including our current results future expectations, include the following:

- A significant amount of our business in our Interactive Distributed Generation, Utility Infrastructure, and Energy Efficiency areas, which are the components of our Energy and Smart Grid Solutions segment, involves large product and service orders. Our revenue and profit in any particular period is significantly influenced by the sales commitments for projects that we receive in periods which precede the reporting period and then are completed and recognized in the reporting period. Accordingly, as we plan our business and evaluate our results, particularly in the short-term, we are focused on the revenue we expect to recognize from projects we have in our revenue backlog, which includes project awards and orders we have received but have not yet completed and recognized, as well as revenue opportunities in our sales pipeline, which includes revenue from projects with respect to which we are in discussion with customers but have not been awarded.
- Our net income in any particular period is significantly influenced by the gross margins on the particular projects we complete, and products and services delivered, and for which revenue is recognized, in that period. Because our projects are virtually all fixed price projects, we are particularly focused on the cost of sales we incur to deliver each of our projects. This cost of sales includes the cost of labor, materials, and other inputs that are directly associated with that particular project. Our projects are priced with gross margin expectations that provide us with our targeted financial returns, and variances from these gross margin expectations are an area we regularly assess. The larger the project or product or service order, the more rigorously it is assessed, because larger projects influence our profit to a greater degree than smaller projects. Our cost of sales and gross margin results on particular projects can affect our future pricing and operational decisions on similar projects, and can also influence our strategic decisions about the products and services we will provide in the future, and the business model we will use to provide them. However, because our projects and orders are generally custom priced, the current market cost of commodity materials is incorporated into the price of our projects and orders, which means that fluctuations in these commodity costs is generally not a major focus of management.
- We generally evaluate our Interactive Distributed Generation business on a project-by-project basis to determine if we are pricing and delivering our products and services profitably, as well as from an overall perspective to determine the levels of revenue, expense, and profit required to deliver sustained profitable growth. We generally evaluate our Energy Efficiency business on a product-by-product basis and a customer-by-customer basis to determine if our products are profitable and customer pricing and service delivery is effective, as well as from an overall perspective to determine the levels of revenue, expense, and profit required to deliver sustained profitable growth. Finally, we generally evaluate our Utility Infrastructure business on a customer-by-customer basis and a project-by-project basis to determine if our services are being priced and executed profitably, as well as from an overall perspective to determine the levels of revenue, expense, and profit required to deliver sustained profitable growth.
- We believe that increasing the amount of Interactive Distributed Generation business we perform under a recurring revenue model will increase our profitability and increase the predictability of our

results. We believe that this, in turn, will increase shareholder value over the long-term. Since our business strategy includes increasing the amount of revenue we generate from recurring revenue contracts, we actively evaluate the progress we are making in this area. In addition, recurring revenue projects generally require us to invest capital at the beginning of the contract term to manufacture and install equipment. These capital expenditures can be significant, and we actively evaluate expectations as to the timing and amount of capital expenditure investments we will make for these recurring revenue projects in the context of our overall revenue and profit expectations, cash and debt position, lender covenants, and other financing constraints. This evaluation includes expectations for capital investments in our revenue backlog as well as our revenue pipeline.

- The growth of our business is dependent on the continued expansion and development of our customer base, our utility relationships, and our new products and services. For this reason, we actively evaluate our sales activity and productivity, revenue pipeline, and new business awards for progress in the growth and development of our customer base. We also actively evaluate the new products and services we are developing for new and existing customers to determine their market opportunity, rate of acceptance, and financial potential.
- We actively evaluate our costs, including staffing, machinery and equipment, facilities, and other overhead, and trends in these costs, in conjunction with our revenue expectations and business opportunities to ensure that we have the right infrastructure in place to maximize our long-term revenue and profit opportunities, while balancing the need to deliver near term profits.
- We actively evaluate and plan our working capital needs, and the impact of these needs on our cash and debt position. The primary areas that require significant working capital are inventory, which tends to increase at the beginning of a project, and at the start of a large order, and receivables, which tend to increase at the end of a project, and at the end of a large order.
- We actively evaluate and plan for our expected revenue and profit results, including the revenue and profit results from our Interactive Distributed Generation, Utility Infrastructure, and Energy Efficiency businesses, which constitute our Energy and Smart Grid Solutions Segment, as well as our Energy Services Area. In our WaterSecure businesses, which currently comprise our Energy Services segment, we actively evaluate the volumes of water we receive and process from customers, the price of oil, and the price of natural gas. These variables are the most significant in determining the equity income and cash distributions we receive from this business.

Uncertainties, Trends, and Risks that can cause Fluctuations in our Operating Results

Our revenues, expenses, margins, net income, cash flow, cash, working capital, debt, and balance sheet position, and other operating results fluctuate significantly from quarter-to-quarter, period-to-period and year-to-year due to a variety of factors. These factors include but are not limited to the following:

- the effects of general economic and financial conditions, including the ongoing challenges in the economy and the difficult capital and credit markets, and the potential for such economic and market challenges to continue or recur in the future, negatively impacting our business operations and our revenues and net income, including the negative impact these conditions could have on the timing of and amounts of orders from our customers, and the potential these factors have to negatively impact our access to capital to finance our business;
- the size, timing and terms of sales and orders, including large customer orders, as well as the effects of the timing of project phases of completion, and customers delaying, deferring or canceling purchase orders or making smaller purchases than expected;
- our ability to increase our revenues through long-term recurring revenue projects, recognizing that increasing revenues from recurring revenue projects will require significant up-front capital expenditures and will protract revenue and profit recognition, while increasing our gross margins over the long-term, as well as our ability to sell, complete, and recognize satisfactory levels of quarterly revenue and profits related to our project-based sales and product and service revenue, in order to maintain current profits, cash flow, and to satisfy our financial covenants in our debt facilities and successfully finance the recurring portion of our business model;
- our ability to maintain and grow our utility infrastructure revenues, and maintain and increase pricing,

utilization rates, and productivity rates, given the significant levels of vehicles, tools, and labor in which we have invested and is required to serve utilities in this business area;

- the recent sale of our Southern Flow business, and the associated loss of revenues, cash flow and income from that business;
- our ability to obtain adequate supplies of key components and materials of suitable quality for our products on a timely and cost-effective basis, including the impact of potential supply line constraints, substandard parts, and fluctuations in the cost of raw materials and commodity prices, including without limitation with respect to our Energy Efficiency business unit in relation to third party manufacturing arrangements we have with vendors in China;
- the performance of our products, services and technologies, and the ability of our systems to meet the performance standards they are designed and built to deliver to our customers, including but not limited to our recurring revenue projects for which we retain the on-going risks associated with the performance and ownership of the systems;
- our ability to access significant capital resources on a timely basis in order to fund working capital requirements, fulfill large customer orders, and finance capital required for recurring revenue projects and equipment for our utility infrastructure business;
- our ability to implement our business plans and strategies and the development of new products and services the timing of such implementation;
- the pace of revenue and profit realization from our new businesses and the development and growth of their markets, including the timing, pricing and market acceptance of our new products and services;
- changes in our pricing policies and those of our competitors, including the introduction of lower cost competing technologies and the potential for them to impact our pricing and our profit margins;
- variations in the length of our sales cycle and product and service delivery and construction process;
- changes in the mix of products and services having differing margins;
- changes in our operating expenses, including prices for materials including but not limited to copper, aluminum, and other raw materials, labor costs, and other components of our products and services, fuel prices including diesel, natural gas, oil and gasoline, and our ability or inability to hedge or otherwise manage these prices to protect our costs and revenues, minimize the impact of volatile exchange rates and mitigate unforeseen or unanticipated expenses;
- changes in our valuation allowance for our net deferred tax asset, and the resulting impact on current tax expense, future tax expense, and balance sheet account balances;
- the effects of severe weather conditions, such as hurricanes, on the business operations of our customers, and the potential effect of such conditions on our results of operations;
- the life cycles of our products and services, and competitive alternatives in the marketplace;
- budgeting cycles of utilities and other industrial, commercial, and institutional customers, including impacts of the current downturn in the economy and difficult capital market conditions on capital projects and other spending items;
- changes and uncertainties in the lead times required to obtain the necessary permits and other governmental and regulatory approvals for projects;
- the development and maintenance of business relationships with strategic partners such as utilities and large customers;
- economic conditions and regulations in the energy industry, especially in the electricity, natural gas and oil sectors, including the effects of changes in energy prices and electricity pricing and utility tariffs;
- changes in the prices charged by our suppliers;
- the effects of governmental regulations and regulatory changes in our markets;
- the effects of litigation, claims and other proceedings; and
- our ability to make and obtain the expected benefits from the development of or acquisition of technology or businesses, and the costs related to such development or acquisitions.

Because we have little or no control over most of these factors, our operating results are difficult to predict. Any substantial adverse change in any of these factors could negatively affect our business and results of operations.

Our revenues and other operating results are heavily dependent upon the size and timing of customer orders, payments, and the timing of the completion of those projects. The timing of large individual sales, and of project completion, is difficult for us to predict. Because our operating expenses are based on anticipated revenues and because a high percentage of these are relatively fixed, a shortfall or delay in recognizing revenue can cause our operating results to vary significantly from quarter-to-quarter and can result in significant operating losses or declines in profit margins in any particular quarter. If our revenues fall below our expectations in any particular quarter, we may not be able to or it may not be prudent to reduce our expenses rapidly in response to the shortfall, which can result in us suffering significant operating losses or declines in profit margins in that quarter.

As we develop new related lines of business, our revenues and costs will fluctuate because generally new businesses require start-up expenses but take time for revenues to develop. Another factor that could cause material fluctuations in our quarterly results is the amount of recurring, as opposed to project-based, sources of revenue for our distributed generation and utility infrastructure projects. To date, the majority of our Energy and Smart Grid Solutions segment revenues have consisted of project-based distributed generation revenues, which are recognized as the project is completed. However, we have marketing efforts focused on developing more sales under our recurring revenue model, for which the costs and capital is invested initially and the related revenue and profit is recognized over the life of the contract, generally five to fifteen years. Recurring revenue projects, compared to project-based sales, are generally more profitable, but result in delayed recognition of revenue and net income, especially in the short-term, as we implement an increased number of these recurring revenue projects.

Our Energy Services segment operating results will vary as a result of fluctuations in energy prices. Results from our WaterSecure operations fluctuate significantly with changes in oil and natural gas prices and production in Colorado.

Due to all of these factors and the other risks discussed in "Item 1A. Risk Factors", quarter-to-quarter, period-to-period or year-to-year comparisons of our results of operations should not be relied on as an indication of our future performance. Quarterly, period or annual comparisons of our operating results are not necessarily meaningful or indicative of future performance.

Recent Developments

On February 17, 2011, we announced that our new family of LED-based street lights is seeing strong adoption by utilities and municipalities. Over the several months prior to this announcement, over 30 electric utilities and municipalities purchased our new LED-based area light, called the "SecureLite." SecureLite provides utilities and municipalities with an energy efficient, environmentally friendly, low maintenance alternative to traditional 100 watt HID lighting. Additionally, we announced that we had introduced two new LED-based street lights to the marketplace, including replacements for traditional 250 and 400 watt HID street lighting. Called "PowerLites," these lights incorporate the same superior engineering as the SecureLite, designed to deliver utilities and municipalities a strong combination of efficiency, environmental, and maintenance benefits for higher wattage applications.

On February 15, 2011, we announced that we received \$10 million of new awards for our Interactive Distributed Generation (IDG) smart grid power systems, and LED lighting products. The new IDG System awards totaled \$7 million, including installations for a broad base of customers, including hospitals, municipal water systems, educational facilities, and retailers. The new LED lighting awards totaled \$3 million, and consisted primarily of an order from a major U.S. retailer to begin retrofitting refrigerated cases with EfficientLights energy saving fixtures. This was our first order from this retailer. Of the \$10 million of new business, \$8 million relates to turn-key product sales of IDG Systems and LED lighting products. We expect this \$8 million of turn-key revenue will be recognized primarily during the first three quarters of 2011. The remaining \$2 million of new business relates to recurring revenue contracts for IDG systems. These systems are expected to be installed during the first half of 2011, and the revenues are expected to be recognized over a fifteen year period.

On January 14, 2011, we completed the sale of our Southern Flow subsidiary to Zedi, Inc., with an effective date of January 1, 2011. Pursuant to the terms of the December 30, 2010 Purchase and Sale Agreement, Zedi, Inc., a Canadian corporation, through its wholly-owned subsidiary, purchased 100% of the stock of Southern Flow. As consideration for that sale, we received cash proceeds of \$16.5 million. The sale of Southern Flow represents a continuation of our strategy to monetize our non-core assets in order to focus on our core Energy and Smart Grid

Solutions business. As a result, we have accounted for the results of operations of our Southern Flow subsidiary as discontinued operations for all periods presented herein. Accordingly, our discussion of financial condition and results of operations excludes the results of operations of our Southern Flow subsidiary for all periods presented.

On January 14, 2011, we amended our credit facility to facilitate the sale of Southern Flow. The amended facility includes modifications to covenants to accommodate the transaction and our financial profile after the transaction, and to resize our credit facility to \$25.0 million in light of the significant cash proceeds we received from the sale of Southern Flow.

On December 23, 2010, we announced that we received \$10 million of new awards for utility infrastructure projects, driven by an award to serve a top U.S. investor-owned utility in a newly established relationship with the Company's UtilityServices business unit. The majority of the \$10 million in expected new revenue is to provide this major utility with construction and maintenance services for its electrical transmission system in 2011. Additionally, the new awards include distribution system upgrade projects for a municipality in the Midwest, and a wastewater treatment system in Texas. We expect the \$10 million of new business to be completed, and the revenue recognized, relatively evenly over the course of 2011.

On December 9, 2010, we announced that we received \$10 million of new awards for our Interactive Distributed Generation (IDG) smart grid power systems. The \$10 million of new business includes \$9 million of recurring revenue contracts for the second award of IDG systems from a major U.S. retail chain to install IDG systems for an expanded number of stores, increasing a program which began in mid-2010. These systems are expected to be installed during the first half of 2011, and the revenues from this contract are expected to be recognized over a five year period. The \$10 million of new business also includes a \$1 million award to deploy an IDG system for a large manufacturing operation, and this award is expected to be recognized as project-based revenue during the first half of 2011. Additionally, we announced that we entered into new master agreements with two additional major U.S. retail chains to deploy IDG systems, the number and specific locations for which are in development. Our IDG systems will deliver these retailers with a more efficient power source during peak power periods, and dependable standby power "24 x 7".

On November 9, 2010, we entered into a multi-year extension of our revolving credit facility, revising the credit facility's expiration date two years to November 12, 2013. This extension was completed to provide us with access to significant capital resources to finance strategic growth initiatives across our business platforms. The credit facility extension also modified and updated certain financial covenants, interest rates, and investment baskets.

On April 30, 2010, we exercised our option and acquired the remaining one-third minority interest in EfficientLights in exchange for 1,025,641 shares of our common stock. The minority interests in EfficientLights were previously owned by the founder, who is also the President of EfficientLights, and five other key employees of EfficientLights. EfficientLights markets and sells LED-based lights that reduce the energy and maintenance costs for refrigerated cases in grocery, drug, and convenience stores, and is in the process of developing other LED-based lighting products, including additional in-store retail lighting, and LED-based parking lot lights, street lights and security lights. As a result, EfficientLights is a wholly-owned subsidiary of our PowerSecure subsidiary and there is no reduction in our net income for net income attributable to the noncontrolling interest in EfficientLights after the date of acquisition.

On April 1, 2010, we launched an expansion of our LED lighting business through the formation and acquisition of a 67% controlling interest in IES, which acquired substantially all of the assets and business of a leading LED lighting development company, Innovative Electronic Solutions, LLC, in order to accelerate the expansion of new LED lighting products and to capitalize on the growing marketplace for LED lighting. The new business has and will continue to design and manufacture new LED-based lighting products for commercial, industrial, and retail customers. We own 67% of the membership interests in, and control the management of, IES. We contributed approximately \$4.4 million to IES to fund the capitalization of IES and the acquisition by IES of substantially all of the assets and business of the seller as well as the assumption by IES of the seller's current liabilities. In connection with its sale and contribution of substantially all of its asset and business to IES, the seller received the remaining 33% membership interests in IES. Both our PowerSecure subsidiary and the seller are subject to various buy-sell rights and obligations with respect to their equity interests in IES, including various call, put and drag-along rights and obligations.

Financial Results Highlights

Our consolidated revenues during 2010 increased by \$12.1 million, a 14.2% increase compared to our consolidated revenues during 2009. The primary drivers of this year-over-year revenue increase were a 21.6% increase in revenues from our Interactive Distributed Generation products and a 24.0% increase in revenues from our Utility Infrastructure products and services, partially offset by an 8.1% decrease in revenues from our Energy Efficiency business.

Our gross profit margin as a percentage of revenue was 36.2% during 2010, a slight decrease of 0.3 percentage points compared to 2009. The decline in gross profit margin reflected changes in the mix of projects and products completed in 2010 compared to 2009, as well as investments we made in equipment and personnel to support new business awards. Additionally, our operating expenses increased in 2010 due to investments we made in our Energy and Smart Grid Solutions Segment to drive and support our future growth, including investments in new product development, engineering, facilities, personnel, selling expense, compensation expense in each of our Distributed Generation, Energy Efficiency, and Utility Infrastructure business areas, as well as additional depreciation expense resulting from capital deployed to support our growing recurring revenue business. As a result, our total operating expenses during 2010 increased by \$7.0 million, or 23.2%, compared to our operating expenses during 2009. In 2011, we expect our operating costs to stabilize at levels at which we operated during the second half of 2010, and then to increase in 2012 and beyond, assuming economic conditions demonstrate sustained improvement and our revenues increase. However, the timing and the amount of this increase in operating expenses will depend on how much and how quickly economic conditions improve and the effects of such economic recovery on our revenues. While we anticipate that an improvement in the economic and financial conditions will lead to an improvement in our business and revenues, we cannot provide any assurance as to when, how much or for how long economic conditions will improve, or the effects of future economic conditions on our revenues, expenses or net income. Over the long-term, we expect to continue to invest in operational infrastructure and sales and new business development to drive and support our growth.

Income from our Energy Services Segment, which consists of our management fees and equity income from the WaterSecure operations, increased by \$1.2 million during 2010 compared to 2009, driven by increases in oil and gas production and pricing.

Our income from continuing operations attributable to PowerSecure International, Inc. shareholders for 2010 was \$0.9 million, or \$0.05 per diluted share, compared to \$1.3 million, or \$0.07 per diluted share, for 2009.

Our income from discontinued operations for 2010, consisting of the operating results of Southern Flow, was \$2.5 million, or \$0.14 per diluted share. This compares to income from discontinued operations for 2009 of \$1.5 million, or \$0.09 per diluted share, which consisted of the operating results of Southern Flow.

In total, our consolidated net income attributable to PowerSecure International, Inc. common stockholders for 2010 was \$3.5 million, or \$0.19 per diluted share, which compared to net income attributable to PowerSecure International, Inc. common stockholders of \$2.8 million, or \$0.16 per diluted share, for 2009.

As discussed below under “—Fluctuations,” our financial results will fluctuate from quarter to quarter and year to year. Thus, there is no assurance that our past results, including the results of our year ended December 31, 2010, will be indicative of our future results, especially in light of the current significant downturn in the economy and unfavorable credit and capital markets.

Backlog

As of the date of this report, our revenue backlog expected to be recognized after December 31, 2010 is \$150 million. This includes revenue related to the new business announcement made by us on February 15, 2011, and is \$12 million more than the \$138 million of revenue backlog we reported in our Quarterly Report on Form 10-Q for the period ended September 30, 2010 filed on November 4, 2010 (the date we last reported our backlog). Our revenue backlog and the estimated timing of revenue recognition is outlined below, including “project-based revenues” expected to be recognized as projects are completed and “recurring revenues” expected to be recognized over the life of the contracts:

Revenue Backlog to be recognized after December 31, 2010

Description	Anticipated Revenue	Estimated Primary Recognition Period
Project-based Revenue -- Near term	\$50 Million	1Q11 through 3Q11
Project-based Revenue -- Long term	\$29 Million	4Q11 through 2013
Recurring Revenue	\$71 Million	1Q11 through 2019
Revenue Backlog to be recognized after December 31, 2010	\$150 Million	

Note: Anticipated revenue and estimated primary recognition periods are subject to risks and uncertainties as indicated in "Cautionary Note Regarding Forward-Looking Statements" above. Consistent with past practice, these amounts are not intended to constitute the Company's total revenue over the indicated time-periods, as the Company has additional, regular on-going revenues. Examples of additional, regular recurring revenues include revenues from the engineering fees, and service revenue, among others. Numbers may not add due to rounding.

Orders in our backlog are subject to delay, deferral, acceleration, resizing, or cancellation from time to time by our customers, subject to contractual rights. Given the irregular sales cycle of customer orders, and especially of large orders, our revenue backlog at any given time is not necessarily an accurate indication of our future revenues.

Operating Segments

We conduct our operations through two operating segments: Energy and Smart Grid Solutions, and Energy Services. Our reportable segments are strategic business units that offer different products and services and serve different customer bases. They are managed separately because each business has a different customer base, requires different technology and personnel, and has different marketing strategies.

Energy and Smart Grid Solutions

Through our PowerSecure subsidiary we serve utilities and commercial, institutional, and industrial customers in the areas of Interactive Distributed Generation, Utility Infrastructure and Energy Efficiency. Each of these PowerSecure subsidiary business units operates in a distinct market with distinct technical disciplines, but share a common or complementary customer base with other PowerSecure subsidiary products and services and which we grow through shared resources and customer relationships. Accordingly, these units are included within our Energy and Smart Grid Solutions segment results.

Energy Services

Through our WaterSecure subsidiary we serve customers in the oil and natural gas production business with water processing and disposal services. WaterSecure, through its equity investment in MM 1995-2, provides water processing and disposal for oil and natural gas producers. Our Southern Flow business has been discontinued and the results of its operations are excluded from our Energy Services segment for all periods presented in the information below as a result of its sale.

Results of Operations

The following discussion regarding segment revenues, gross profit, costs and expenses, and other income and expenses for 2010 compared to 2009, and for 2009 compared to 2008, excludes revenues, gross profit, and costs and expenses of our Southern Flow subsidiary, which we sold and is classified as a discontinued operation in our financial statements.

2010 Compared to 2009

Revenues

Our consolidated revenues are generated entirely by sales and services provided by our PowerSecure subsidiary, which operates our Energy and Smart Grid Solutions segment. We currently provide a variety of Energy and Smart Grid Solutions products and services through three product categories: Interactive Distributed Generation, Utility Infrastructure, and Energy Efficiency. The following table summarizes our Energy and Smart Grid Solutions segment revenues for the periods indicated (dollars in thousands):

	Year Ended December 31,		Year-over-Year Difference	
	2010	2009	\$	%
Energy and SmartGrid Solutions:				
Interactive Distributed Generation	\$ 52,142	\$ 42,889	\$ 9,253	21.6%
Utility Infrastructure	24,275	19,584	4,691	24.0%
Energy Efficiency	21,097	22,953	(1,856)	-8.1%
Total	<u>\$ 97,514</u>	<u>\$ 85,426</u>	<u>\$ 12,088</u>	14.2%

Our consolidated revenues for 2010 increased \$12.1 million, or 14.2%, compared to 2009 due primarily to an increase in sales of our Interactive Distributed Generation and Utility Infrastructure products and services, partially offset by a decrease in sales of our Energy Efficiency products and services.

Our Energy and Smart Grid Solutions segment distributed generation revenues are very heavily affected by the number, size and timing of our Interactive Distributed Generation projects as well as the percentage of completion of in-process projects, and the percentage of turn-key as opposed to recurring revenue projects. Our Interactive Distributed Generation sales have fluctuated significantly in the past and are expected to continue to fluctuate significantly in the future. Our Energy and Smart Grid Solutions segment revenues increased by \$12.1 million, or 14.2%, during 2010 compared to 2009. The increase in those revenues in 2010 over 2009 was primarily attributable to a \$9.3 million, or 21.6%, increase in revenues from our Interactive Distributed Generation products and services and a \$4.7 million, or 24.0%, increase in revenues from our Utility Infrastructure products and services. These increases were partially offset by a \$1.9 million, or 8.1%, decrease in revenues from our Energy Efficiency products and services. The increase in our Interactive Distributed Generation product sales and services reflects gradual improvements in economic conditions and increased business investment spending by large industrial, institutional, and municipal customers. The increase in our Utility Infrastructure product sales and services was due to an increase in the number of utilities that we service, and an increase in those customers' spending levels on transmission and distribution system maintenance and construction. The decrease in our Energy Efficiency sales and services reflects a slower pace of LED-based "reach-in" refrigerated case light sales in 2010 compared to 2009, due to a more cautious pace of investment spending by retail customers in 2010.

The future level of our revenues will depend on the timing and degree of the recovery of the domestic economy, the health of the credit markets and the return to pre-recession levels of customer spending for capital improvements and energy efficiency, as well as our ability to secure new significant purchase orders. The level and timing of our future revenues will also be affected by the amount and proportion of revenues coming from recurring revenue projects in the future, which results in revenue being recognized over a longer period. We are particularly susceptible to changes in economic conditions due to the fact that our product offerings are largely discretionary investment items for our customers, and this can therefore subject them to delay or deferment especially when economic conditions are not positive.

While it appears that economic and credit conditions are beginning to improve, the modest and inconsistent pace of recovery leads us to expect our Energy and Smart Grid Solutions segment revenues will remain soft in early 2011, with gradual improvement in our quarterly revenues as 2011 progresses. We expect this general pattern of modest, gradual improvement in revenues for each of our Distributed Generation, Energy Efficiency, and Utility Infrastructure areas. The absolute pace of our revenue growth will depend on how quickly economic conditions improve and the confidence with which our utility partners and customers believe the economy will demonstrate a consistent recovery.

Gross Profit and Gross Profit Margin

Our segment gross profit represents our revenues less our cost of sales. Our segment gross profit margin represents our gross profit divided by our revenues. The following tables summarizes our Energy and Smart Grid Solutions segment cost of sales along with our segment gross profit and gross profit margin for the periods indicated (dollars in thousands):

	Year Ended December 31,		Year-over-Year Difference	
	2010	2009	\$	%
Energy and Smart Grid Solutions:				
Cost of Sales	\$ 62,220	\$ 54,231	\$ 7,989	14.7%
Gross Profit	\$ 35,294	\$ 31,195	\$ 4,099	13.1%
Gross Profit Margin	36.2%	36.5%		

Cost of sales and services include materials, personnel and related overhead costs incurred to manufacture products and provide services. The 14.7% increase in our consolidated cost of sales and services for 2010, compared to 2009, was driven by the increase in costs associated with the 14.2% increase in sales.

Our Energy and Smart Grid Solutions segment gross profit increased \$4.1 million, or 13.1%, in 2010, compared to 2009. As a percentage of revenue, our Energy and Smart Grid Solutions segment gross profit margin decreased by 0.3 percentage points in 2010 compared to 2009, to 36.2%. The slight decrease in our Energy and Smart Grid Solutions gross profit margin reflects changes in the mix of projects and products completed in 2010 compared to 2009, as well as investments we made in equipment and personnel to support new business awards. In the long-term, however, we expect that gross profit margins for this segment will increase because of greater productivity, operations and manufacturing efficiencies, improvements in technology, and because of a growth in our higher-margin recurring revenue projects.

Our gross profit and gross profit margin have been, and we expect will continue to be, affected by many factors, including the following:

- The absolute level of revenue achieved in any particular period, given that portions of our cost of sales are relatively fixed over the near-term, the most significant of which is personnel and equipment costs;
- Our ability to improve our operating efficiency and benefit from economies of scale;
- Our level of investments in our businesses, particularly for anticipated or new or business awards;
- The mix of higher and lower margin projects, products and services, and the impact of new products and technologies on our pricing and volumes;
- Our ability to manage our materials and labor costs, including any future inflationary pressures;
- The costs to maintain and operate distributed generation systems we own in conjunction with recurring revenue contracts, including the price of fuel, as well as their operating performance;
- The geographic density of our projects;
- The selling price of products and services sold to customers, and the revenues we expect to generate from recurring revenue projects;
- The rate of growth of our new businesses, which tend to incur costs in excess of revenues in their earlier phases and then become profitable and more efficient over time if they are successful; and
- Other factors described below under “—Fluctuations.”

Some of these factors are not within our control, and we cannot provide any assurance that we can continue to improve upon those factors that are within our control, especially given the current economic climate as well as our movement to an expected higher percentage of recurring revenue projects. Moreover, our gross revenues are likely to fluctuate from quarter to quarter and from year to year, as discussed in “—Fluctuations” below. Accordingly, there is no assurance that our future gross profit margins will improve or even remain at historic levels in the future, and will likely decrease if revenues decrease.

Operating Expenses

Our operating expenses include general and administrative expense, selling, marketing and service expense, and depreciation and amortization. The following table sets forth our consolidated operating expenses for the periods indicated (dollars in thousands):

	Year Ended December 31,		Year-over-Year Difference	
	2010	2009	\$	%
Consolidated Operating Expenses:				
General and administrative	\$ 29,339	\$ 24,169	\$ 5,170	21.4%
Selling, marketing and service	5,154	3,927	1,227	31.2%
Depreciation and amortization	2,754	2,144	610	28.5%
Total	<u>\$ 37,247</u>	<u>\$ 30,240</u>	<u>\$ 7,007</u>	23.2%

Costs related to personnel, including wages, stock compensation, bonuses and commissions, are the most significant component of our operating expenses. During 2010, our operating expenses increased due to investments in new product development, engineering, facilities, and personnel, as well as increases in selling expense, compensation expense, and increases in depreciation from capital deployed to support our recurring revenue business. Our operating expense investments were in support of, and driven by, increasing levels of revenue and identified new business opportunities. By contrast, in 2009, as a result of weak economic conditions, we took actions to reduce our operating expenses. These measures in 2009 included staff reductions and compensation measures such as reductions in certain bonus plans and other employee incentives, and other sales and general and administrative spending reductions. In the future, we expect to continue to make investments designed to support and drive our future business growth, subject to the general economic conditions demonstrating sustained improvement and our continuing positive expectations regarding our future growth opportunities. We expect our 2011 quarterly operating expense levels to be similar to our quarterly operating expenses during the second half of 2010. In 2012 and beyond, if economic conditions continue to improve, we expect demand for our business to expand allowing us to grow our business and to invest in future business opportunities.

General and Administrative Expenses. General and administrative expenses include personnel wages, benefits, stock compensation, and bonuses and related overhead costs for the support and administrative functions incurred primarily in our Energy and Smart Grid Solutions segment. The 21.4% increase in our consolidated general and administrative expenses in 2010, as compared to 2009, was due to investment in personnel and other administrative expenses to support our increasing levels of revenue and investments in new business opportunities. The following table provides further detail of our general and administrative expenses by segment (dollars in thousands):

	Year Ended December 31,		Year-over-Year Difference	
	2010	2009	\$	%
Segment G&A Expenses:				
Energy and Smart Grid Solutions:				
Personnel costs	\$ 15,156	\$ 12,487	\$ 2,669	21.4%
Vehicle lease and rental	1,814	1,829	(15)	-0.8%
Insurance	1,069	1,028	41	4.0%
Rent-office and equipment	931	776	155	20.0%
Professional fees and consulting	894	456	438	96.1%
Travel	1,070	716	354	49.4%
Development costs	362	170	192	112.9%
Other	2,689	1,665	1,024	61.5%
Energy Services	-	-	-	n/m
Unallocated Corporate Costs	5,354	5,042	312	6.2%
Total	<u>\$ 29,339</u>	<u>\$ 24,169</u>	<u>\$ 5,170</u>	21.4%

The increase in our Energy and Smart Grid Solutions segment personnel costs during 2010, as compared to 2009, was due to staffing increases to support growth in our Energy and Smart Grid Solutions Segment and investments in new business opportunities. Other general and administrative expenses including insurance, professional and consulting fees, travel and other expenses similarly increased to support our current growth and future growth opportunities. In the near-term, we expect our Energy and Smart Grid Solutions general and administrative expenses to remain relatively consistent from our second half of fiscal 2010 levels as we continue to

support the near-term growth of our business. Over the long-term, we expect our expenses in these areas to further increase at our Energy and Smart Grid Solutions segment as we continue to invest in and support long-term growth.

Unallocated corporate general and administrative expenses include similar personnel costs as described above as well as costs incurred for the benefit of all of our business operations, such as legal, Sarbanes-Oxley, public company reporting, director expenses, accounting costs, and stock compensation expense on our stock options and restricted stock grants which we do not allocate to our operating segments. The increase in unallocated corporate costs during 2010 as compared to 2009 was due to increased personnel costs, incentive compensation costs and public company reporting costs. We expect our unallocated corporate costs in 2011 to remain at approximately the same levels as we incurred during 2010.

Selling, Marketing and Service Expenses. Selling, marketing and service expenses consist of personnel and related overhead costs, including commissions for sales and marketing activities, together with travel, advertising and promotion costs incurred in our Energy and Smart Grid Solutions segment. The 31.2% increase in selling, marketing and service expenses in 2010, as compared to 2009, was due to increases in sales compensation expense driven by the current period increases in revenues as well as increases in advertising, promotion, and travel to stimulate revenue growth and respond to an increasing level of sales opportunities at our Energy and Smart Grid Solutions segment. The following table provides further detail of our segment selling, marketing and service expenses (dollars in thousands):

	Year Ended December 31		Year-over-Year Difference	
	2010	2009	\$	%
Segment Selling, Marketing and Service:				
Energy and Smart Grid Solutions:				
Salaries	\$ 2,330	\$ 1,859	\$ 471	25.3%
Commission	1,312	1,219	93	7.6%
Travel	772	514	258	50.2%
Advertising and promotion	535	307	228	74.3%
Bad debt expense (recovery)	205	28	177	632.1%
Energy Services	-	-	-	n/m
Total	\$ 5,154	\$ 3,927	\$ 1,227	31.2%

In the future, we expect our near-term and long-term Energy and Smart Grid Solutions segment selling, marketing and services expenses to grow in order to reflect, drive and support future growth.

Depreciation and Amortization Expenses. Depreciation and amortization expenses include the depreciation of property, plant and equipment and the amortization of certain intangible assets including capitalized software development costs and other intangible assets. The 28.5% increase in depreciation and amortization expenses in 2010, as compared to 2009, primarily reflects increased depreciation and amortization resulting from capital investments at our Energy and Smart Grid Solutions segment throughout 2010 and late 2009. These capital investments are primarily investments in PowerSecure-owned distributed generation systems for projects deployed under our recurring revenue model.

Other Income and Expenses

Our other income and expenses include management fees and equity income earned by our Energy Services segment as managing trustee of MM 1995-2 relating to the WaterSecure operations, interest income, interest expense and income taxes. The following table sets forth our other income and expenses for the periods indicated, by segment (dollars in thousands):

	Year Ended December 31,		Year-over-Year Difference	
	2010	2009	\$	%
Other Segment Income and (Expenses):				
Energy and Smart Grid Solutions:				
Interest income and other income	\$ -	\$ 3	\$ (3)	-100.0%
Interest expense	(341)	(334)	(7)	-2.1%
Segment total	<u>(341)</u>	<u>(331)</u>	<u>(10)</u>	
Energy Services:				
Equity income	3,182	2,167	1,015	46.8%
Management fees	583	447	136	30.4%
Segment total	<u>3,765</u>	<u>2,614</u>	<u>1,151</u>	
Unallocated Corporate:				
Interest income and other income	99	158	(59)	-37.3%
Interest expense	(278)	(273)	(5)	-1.8%
Income tax benefit (provision)	(526)	(331)	(195)	-58.9%
Segment total	<u>(705)</u>	<u>(446)</u>	<u>(259)</u>	
Total	<u>\$ 2,719</u>	<u>\$ 1,837</u>	<u>\$ 882</u>	

Equity Income. Equity income at our Energy Services segment consists of our minority ownership interest in the earnings of the WaterSecure operations. Our equity income is a direct function of the net income of the WaterSecure operations. During 2010, our equity income increased by \$1.0 million, or 46.8%, over 2009. The performance of the WaterSecure operations, and our related equity income, was favorably affected by increases in oil and natural gas prices and production in 2010 compared to 2009.

Management Fees. Management fees at our Energy Services segment consist entirely of fees we earn as the managing trustee of the WaterSecure operations. These fees, to a large extent, are based on a percentage of the revenues of the WaterSecure operations. Increases in oil and natural gas prices and production in 2010 compared to 2009, positively affected the revenues of the WaterSecure operations in 2010. As a direct result, our Energy Services segment management fees increased in 2010 by 30.4% compared to 2009.

Interest Income and Other Income. Interest income and other income for each segments consists primarily of interest we earn on the interest-bearing portion of our cash and cash equivalent balances. In total, interest income and other income decreased by \$62 during 2010, as compared to 2009. This decrease was attributable to a decline in our interest income resulting from both a decline in our interest-bearing cash and cash equivalent balances as well as declining interest rates earned on our cash and cash equivalent balances in 2010 compared to 2009. Our future interest income will depend on our cash and cash equivalent balances, which will increase and decrease depending upon our profit, capital expenditures, and our working capital needs, and future interest rates.

Interest Expense. Interest expense for each segment consists of interest and finance charges on our credit facilities and capital leases. In total, interest expense increased by \$12 during 2010, as compared to 2009. The increase in our interest expense reflects the increased borrowings under our credit facility during the second half of 2010, partially offset by the reduction in balances outstanding on our capital lease obligation due to regular payments made on our capital leases over the year. We expect our future interest and finance charges to increase over time as a result of anticipated borrowings under our credit facility to fund future working capital needs and recurring revenue projects at our Energy and Smart Grid Solutions segment.

Income Taxes. Historically, our current federal income tax expense has been modest, generally limited to federal alternative minimum tax, because of our consolidated net operating losses in prior years that are used to offset taxable income in current years. Our income tax provision includes the effects of federal alternative minimum tax, changes in our deferred tax assets and liabilities, changes in the valuation allowance for our net deferred tax asset, state income taxes in various state jurisdictions in which we have taxable activities, and expenses associated with uncertain tax positions that we have taken or expense reductions from tax positions as a result of a lapse of the applicable statute of limitations. The increase in our 2010 income tax provision compared to our 2009 income tax provision was due to the effects of increases in state income taxes in 2010 compared to 2009 as well as the favorable effect on our tax provision of bonus depreciation related to significant capital expenditures in 2009.

Noncontrolling Interest. Until April 30, 2010, we owned the controlling, but not the entire, interest in EfficientLights at which time we acquired the noncontrolling member's remaining 33% interest in EfficientLights. Also, on April 1, 2010, we acquired a controlling, but not the entire, interest in IES. The financial results of EfficientLights and IES are consolidated into our financial results, and the noncontrolling members' 33% interest in the income (loss) of EfficientLights (until April 30, 2010) and IES (commencing April 1, 2010) is reflected as an adjustment to net income to derive net income attributable to PowerSecure International, Inc. shareholders in our consolidated statement of operations. The reduction for the noncontrolling interest in the income (loss) of EfficientLights and IES decreased by \$1.7 million in 2010 compared to 2009 as a result of start up and development expenses of IES, which we acquired on April 1, 2010. IES's loss during 2010 was only partially offset by income related to the EfficientLights noncontrolling interest prior to April 30, 2010. After the exercise of our option to acquire the minority interest position in EfficientLights on April 30, 2010, there was no further noncontrolling interest in EfficientLights to reduce net income attributable to PowerSecure International shareholders, although there will continue to be reductions or additions to net income attributable to PowerSecure International shareholders for the noncontrolling members' interest in IES. Accordingly, changes in the aggregate amount of income or losses attributable to our noncontrolling interests are not necessarily comparable from period to period.

2009 Compared to 2008

Revenues

The following table summarizes our Energy and Smart Grid Solutions segment revenues for the periods indicated (dollars in thousands):

	Year Ended December 31,		Year-over-Year Difference	
	2009	2008	\$	%
Energy and SmartGrid Solutions:				
Interactive Distributed Generation	\$ 42,889	\$ 84,369	\$ (41,480)	-49.2%
Utility Infrastructure	19,584	25,361	(5,777)	-22.8%
Energy Efficiency	22,953	6,263	16,690	266.5%
Total	<u>\$ 85,426</u>	<u>\$ 115,993</u>	<u>\$ (30,567)</u>	-26.4%

Our consolidated revenues for 2009 decreased \$30.6 million, or 26.4%, compared to 2008, due primarily to a decrease in our Interactive Distributed Generation and Utility Infrastructure sales and services, partially offset by an increase in our Energy Efficiency product sales and services.

Our Energy and Smart Grid Solutions segment distributed generation revenues are significantly affected by the number, size and timing of our Interactive Distributed Generation projects as well as the percentage of completion of in-process projects, and the percentage of turn-key as opposed to recurring revenue projects. Our Interactive Distributed Generation sales have fluctuated significantly in the past and are expected to continue to fluctuate significantly in the future. Our Energy and Smart Grid Solutions segment revenues decreased by \$30.6 million, or 26.4%, during 2009 compared to 2008. The decrease in our Energy and Smart Grid Solutions segment revenues was due to a 49.2% decrease in revenues from our Interactive Distributed Generation products and services and a 22.8% decrease in revenues from our Utility Infrastructure products and services. These decreases were partially offset by a 266.5% increase in revenues from our Energy Efficiency products and services. The \$41.5 million, or 49.2%, decrease in revenues from our Interactive Distributed Generation product sales and services in 2009 over 2008 was primarily attributable to a \$34.9 million decline in revenues from Publix Supermarkets, our largest customer in 2008, along with the combination of the difficult economic environment, the uncertain regulatory environment, and the difficult capital markets which reduced capital spending by our customers. The decline in revenues from Publix is due to the completion in 2008 of the majority of the Publix distributed generation systems awarded to us. The economic downturn and difficult capital markets also negatively affected the demand for our products and services, as well as our ability to fully replace the reduced revenues from Publix with revenues from projects with other customers. Revenues from our Utility Infrastructure products and services in 2009 were also negatively affected by the economic downturn and difficult capital markets resulting in a \$5.8 million, or 22.8%, decrease in Utility Infrastructure revenues compared to 2008. The increase in revenues from our Energy Efficiency products and services in 2009 compared to 2008 was due to the rapid growth of sales of our EfficientLights LED lighting technology products and services in 2009, primarily driven by sales of our LED-based "reach-in" refrigerated case lights.

Gross Profit and Gross Profit Margins

The following tables summarizes our Energy and Smart Grid Solutions segment cost of sales along with our segment gross profit and gross profit margin for the periods indicated (dollars in thousands):

	Year Ended December 31,		Year-over-Year Difference	
	2009	2008	\$	%
Energy and Smart Grid Solutions:				
Cost of Sales	\$ 54,231	\$ 77,550	\$ (23,319)	-30.1%
Gross Profit	\$ 31,195	\$ 38,443	\$ (7,248)	-18.9%
Gross Profit Margin	36.5%	33.1%		

The 30.1% decrease in our Energy and Smart Grid Solutions segment cost of sales and services in 2009, compared to 2008, was driven by a 26.4% decrease in our sales and services revenue, together with factors leading to the improvement in our gross profit margin. Although our Energy and Smart Grid Solutions segment gross profit, in total dollars, decreased \$7.2 million, or 18.9%, in 2009, compared to 2008, our gross profit margin increased by 3.4 percentage points in 2009 over 2008, to 36.5%. A total of \$10.1 million of our gross profit decrease was driven by the decline in our revenue, partially offset by the positive effects of a \$2.9 million improvement in our gross profit due to the favorable mix of projects in 2009 with higher gross margins than in 2008, as well as due to reductions in costs taken in response to anticipated negative economic conditions. Specific cost reduction measures taken in 2009 include reductions in construction personnel, vehicles, and other operational spending reductions.

Operating Expenses

The following table sets forth our consolidated operating expenses for the periods indicated (dollars in thousands):

	Year Ended December 31,		Year-over-Year Difference	
	2009	2008	\$	%
Consolidated Operating Expenses:				
General and administrative	\$ 24,169	\$ 27,128	\$ (2,959)	-10.9%
Selling, marketing and service	3,927	5,325	(1,398)	-26.3%
Depreciation and amortization	2,144	1,847	297	16.1%
Total	\$ 30,240	\$ 34,300	\$ (4,060)	-11.8%

Costs related to personnel, including wages, stock compensation, bonuses and commissions, are the most significant component of our operating expenses. In anticipation of the recent economic recession and in anticipation of a decline in revenues during a significant portion of 2009, we took measures during late 2008 and in 2009 to reduce our operating expenses. These measures included staff reductions and compensation measures such as reductions in certain bonus plans and other employee incentives, and other sales and general and administrative spending reductions.

General and Administrative Expenses. The 10.9% decrease in our consolidated general and administrative expenses in 2009, as compared to 2008, was due to staff reductions, decreases in incentive compensation expense, and other measures taken primarily in our Energy and Smart Grid Solutions segment to control and reduce our costs. The following table provides further detail of our general and administrative expenses by segment (dollars in thousands):

	Year Ended December 31,		Year-over-Year Difference	
	2009	2008	\$	%
Segment G&A Expenses:				
Energy and Smart Grid Solutions:				
Personnel costs	\$ 12,487	\$ 14,311	\$ (1,824)	-12.7%
Vehicle lease and rental	1,829	2,449	(620)	-25.3%
Insurance	1,028	941	87	9.2%
Rent-office and equipment	776	844	(68)	-8.1%
Professional fees and consulting	456	504	(48)	-9.5%
Travel	716	864	(148)	-17.1%
Development costs	170	118	52	44.1%
Other	1,665	2,082	(417)	-20.0%
Energy Services	-	7	(7)	-100.0%
Unallocated Corporate Costs	5,042	5,008	34	0.7%
Total	<u>\$ 24,169</u>	<u>\$ 27,128</u>	<u>\$ (2,959)</u>	<u>-10.9%</u>

The decrease in our Energy and Smart Grid Solutions segment personnel costs during 2009, as compared to 2008; was due to staff reductions, decreases in incentive compensation expense, and other actions taken to reduce costs in anticipation of a decrease in revenues at our PowerSecure subsidiary. Other general and administrative expenses including vehicle lease and rental, travel and other expenses decreased as a result of our specific cost reduction efforts.

Unallocated corporate general and administrative expenses include similar personnel costs as described above as well as costs incurred for the benefit of all of our business operations, such as legal, Sarbanes-Oxley, public company reporting, director expenses, accounting costs, and stock compensation expense on our stock options and restricted stock grants which we do not allocate to our operating segments. Overall, these costs increased less than 1% during 2009 as compared to 2008 due to an increase in public company costs.

Selling, Marketing and Service Expenses. The overall 26.3% decrease in selling, marketing and service expenses in 2009, as compared to 2008, was due primarily to reductions in sales compensation expense resulting from the decline in revenues at our Energy and Smart Grid Solutions segment in 2009. The following table provides further detail of our segment selling, marketing and service expenses (dollars in thousands):

	Year Ended December 31,		Year-over-Year Difference	
	2009	2008	\$	%
Segment Selling, Marketing and Service:				
Energy and Smart Grid Solutions:				
Salaries	\$ 1,858	\$ 2,140	\$ (282)	-13.2%
Commission	1,219	2,025	(806)	-39.8%
Travel	514	614	(100)	-16.3%
Advertising and promotion	307	323	(16)	-5.0%
Bad debt expense	28	204	(176)	-86.3%
Other	1	19	(18)	-94.7%
Energy Services	-	-	-	n/m
Total	<u>\$ 3,927</u>	<u>\$ 5,325</u>	<u>\$ (1,398)</u>	<u>-26.3%</u>

Depreciation and Amortization Expenses. The \$297, or 16.1%, overall increase in depreciation and amortization expenses in 2009, as compared to 2008, reflects increased depreciation and amortization resulting from capital investments we made at our Energy and Smart Grid Solutions segment throughout 2008 and 2009. These capital investments are primarily investments in PowerSecure-owned distributed generation systems for projects deployed under our recurring revenue model.

Other Income and Expenses

The following table sets forth our other income and expenses for the periods indicated, by segment (dollars in thousands):

	Year Ended December 31,		Year-over-Year Difference	
	2009	2008	\$	%
Other Segment Income and (Expenses):				
Energy and Smart Grid Solutions:				
Interest income and other income	\$ 3	\$ 82	\$ (79)	-96.3%
Interest expense	(334)	(140)	(194)	138.6%
Segment total	<u>(331)</u>	<u>(58)</u>	<u>(273)</u>	
Energy Services:				
Equity income	2,167	3,490	(1,323)	-37.9%
Management fees	447	556	(109)	-19.6%
Interest income and other income	-	-	-	n/m
Segment total	<u>2,614</u>	<u>4,046</u>	<u>(1,432)</u>	
Unallocated Corporate:				
Interest income and other income	158	382	(224)	-58.6%
Interest expense	(273)	(147)	(126)	-85.7%
Income tax benefit (provision)	(331)	(729)	398	54.6%
Segment total	<u>(446)</u>	<u>(494)</u>	<u>48</u>	
Total	<u>\$ 1,837</u>	<u>\$ 3,494</u>	<u>\$ (1,657)</u>	

Equity Income. During 2009, our equity income decreased by \$1.3 million, or 37.9%, compared to 2008. The performance of the WaterSecure operations, and our related equity income, was negatively affected by soft market conditions and prices in the oil and gas sector generally, and in the region in which it operates, during 2009.

Management Fees. Due to the economic downturn and the significant reduction in oil and gas prices during early 2009 compared to 2008, market conditions in the oil and gas sector were substantially weaker in 2009 compared to 2008. These weaker conditions negatively affected the revenues of the WaterSecure operations in 2009. As a direct result, our Energy Services segment management fees decreased in 2009 by \$109, or 19.6%, compared to 2008.

Interest Income and Other Income. In total, interest income and other income decreased by \$303 during 2009, as compared to 2008. This decrease was attributable to a decline in our interest income resulting from declining interest rates earned on our cash and cash equivalent balances in 2009 compared to 2008.

Interest Expense. In total, interest expense increased by \$320 during 2009, as compared to 2008. The increase in our unallocated corporate interest expense reflects the unused revolving credit facility fee and amortization of our finance charges incurred on our credit facility. The increase in our Energy and Smart Grid Solutions segment interest expense reflects interest and amortized finance charges on the \$5.2 million balance on the capital lease obligation which we entered into in December 2008 to finance certain recurring revenue projects.

Income Taxes. The decrease in our 2009 income tax provision compared to 2008 is due primarily to the reduction in net income before taxes in 2009 compared to 2008 partially offset by the effects of an increase in expense associated with certain tax positions that we took in 2009 compared to 2008.

Noncontrolling Interest. The noncontrolling interest amount of \$1.5 million during 2009, shown as a reduction to net income attributable to PowerSecure International, Inc. common stockholders, represents the 33% interest in the income of EfficientLights owned by the noncontrolling member. In 2008, EfficientLights incurred a loss and had accumulated losses in excess of the noncontrolling member's interest in EfficientLights. Under accounting standards that existed in 2008, no losses attributable to the noncontrolling member's interest in EfficientLights were recognized in our financial statements in 2008. During 2009, EfficientLights became profitable and the portion of its net income attributable to the noncontrolling member is reflected as a reduction to net income attributable to PowerSecure International, Inc. common stockholders.

Fluctuations

Our revenues, expenses, margins, net income, cash flow, cash, working capital, debt, balance sheet positions, and other operating results have fluctuated significantly from quarter-to-quarter, period-to-period and year-to-year in the past and are expected to continue to fluctuate significantly in the future due to a variety of factors, many of which are outside of our control. See the discussion of various factors and the related impact of those factors in "How We Evaluate our Business Performance and Opportunities - Uncertainties, Trends and Risks that can cause Fluctuations in our Operating Results" above.

Due to these factors and the other risks discussed in "Item 1A. Risk Factors", quarter-to-quarter, period-to-period or year-to-year comparisons of our results of operations should not be relied on as an indication of our future performance. Quarterly, period or annual comparisons of our operating results are not necessarily meaningful or indicative of future performance.

Liquidity and Capital Resources

Overview

We have historically financed our operations and growth primarily through a combination of cash on hand, cash generated from operations, borrowings under credit facilities, leasing, and proceeds from private and public sales of equity. On a going forward basis, we expect to require capital primarily to finance our:

- operations;
- inventory, accounts receivable, and working capital needs;
- property and equipment expenditures, including capital expenditures related to recurring revenue projects;
- additional equity investments in our WaterSecure operations;
- software purchases or development;
- debt service requirements;
- lease obligations;
- deferred compensation obligations; and
- business and technology acquisitions and other growth transactions.

Working Capital

At December 31, 2010, we had working capital of \$54.5 million, including \$8.2 million in cash and cash equivalents, compared to working capital of \$47.2 million at December 31, 2009, which included \$20.2 million in cash and cash equivalents. Subsequent to December 31, 2010, we received \$16.5 million in gross cash proceeds from the sale of Southern Flow. Changes in the components of our working capital from 2009 to 2010 and from 2008 to 2009 are explained in greater detail below. At December 31, 2010, we had \$20.0 million of additional borrowing capacity from our credit facility, as amended in January 2011, compared to \$50.0 million available at December 31, 2009, due to amendments made to accommodate the sale of our Southern Flow business. The availability of this capacity under our credit facility includes restrictions on the use of proceeds, and is dependent upon our ability to satisfy certain financial and operating covenants including financial ratios and a minimum cash balance, as discussed below.

Cash Flows

The following table summarizes our cash flows for the periods indicated (amounts in thousands):

	Year Ended December 31,		
	2010	2009	2008
Net cash flows provided by (used in) operating activities	\$ (6,638)	\$ (614)	\$ 8,447
Net cash flows used in investing activities	(10,840)	(3,779)	(19,017)
Net cash provided by financing activities	5,511	246	6,176
Net decrease in cash and cash equivalents	<u>\$ (11,967)</u>	<u>\$ (4,147)</u>	<u>\$ (4,394)</u>

Cash Flows Provided by (Used in) Operating Activities

Cash provided by (used in) operating activities consists primarily of net income adjusted for certain non-cash items including depreciation and amortization, stock-based compensation expenses, noncontrolling interest, and equity income. Cash provided by (used in) operating activities also include cash distributions from our unconsolidated affiliate, cash distributions to the EfficientLights noncontrolling member and the effect of changes in working capital and other activities.

Cash used in operating activities of \$6.6 million in 2010 included the effects of the following:

- our income from continuing operations of \$0.8 million;
- non-cash charges of \$2.8 million in depreciation and amortization;
- non-cash stock-based compensation expense of \$2.1 million;
- cash distributions of \$0.9 million to the noncontrolling member of EfficientLights;
- non-cash equity income from our WaterSecure operations of \$3.2 million partially offset by cash distributions from those operations of \$2.7 million;
- non-cash deferred income tax expense of \$0.3 million;
- an increase of \$4.0 million in accounts receivable;
- an increase of \$5.3 million in inventories;
- a decrease of \$0.5 million in other current assets and liabilities;
- an increase of \$3.8 million of accounts payable;
- a decrease of \$8.6 million of accrued expenses;
- an increase of \$0.2 million of unrecognized tax benefits;
- cash payments of \$0.3 million on our restructuring obligations;
- an increase in our deferred compensation obligation of \$0.3 million; and
- cash provided by our discontinued operations of \$2.8 million.

Cash used in operating activities of \$0.6 million in 2009 included the effects of the following:

- our income from continuing operations of \$2.8 million;
- non-cash charges of \$2.1 million in depreciation and amortization;
- non-cash stock-based compensation expense of \$2.2 million;
- cash distributions of \$0.4 million to the noncontrolling member of EfficientLights;
- cash distributions from our WaterSecure operations of \$2.2 million offset by non-cash equity income from those operations of \$2.2 million;
- non-cash deferred income tax expense of \$0.2 million;
- an increase of \$3.1 million in accounts receivable;
- an increase of \$1.6 million in inventories;
- a decrease of \$0.2 million in other current assets and liabilities;
- a decrease of \$1.7 million of accounts payable;
- a decrease of \$2.7 million of accrued expenses;
- an increase of \$0.6 million of unrecognized tax benefits;
- cash payments of \$1.4 million on our restructuring obligations;
- an increase in our deferred compensation obligation of \$0.3 million; and
- cash provided by our discontinued operations of \$1.7 million.

Cash provided by operating activities of \$8.4 million in 2008 included the effects of the following:

- our net income from continuing operations of \$7.6 million;

- non-cash charges of \$1.8 million in depreciation and amortization;
- non-cash stock-based compensation expense of \$2.6 million;
- cash distributions from our WaterSecure operations of \$3.7 million partially offset by non-cash equity income from those operations of \$3.5 million;
- a decrease of \$11.5 million in accounts receivable;
- a decrease of \$1.4 million in inventories;
- a decrease of \$5.5 million of accounts payable;
- a decrease of \$12.0 million of accrued expenses;
- cash payments of \$4.0 million on our restructuring obligations; and
- cash provided by our discontinued operations of \$4.9 million.

Cash Used in Investing Activities

Cash used in investing activities was \$10.8 million, \$3.8 million and \$19.0 million for 2010, 2009 and 2008, respectively. Historically, our principal cash investments have related to the purchase of equipment used in our production facilities, the acquisitions of certain contract rights, the acquisition and installation of equipment related to our recurring revenue sales, and the acquisition of businesses or technologies. During 2010, we used \$4.4 million to acquire a 67% ownership interest in IES, \$2.6 million to purchase and install equipment at our recurring revenue distributed generation sites, \$3.5 million at our PowerSecure subsidiary principally to acquire operational assets, and \$0.3 million was used by our discontinued operations. During 2009, we used \$1.6 million to purchase and install equipment at our recurring revenue distributed generation sites, \$0.8 million to acquire inventory and equipment of Design Power International, Inc., \$1.0 million at our PowerSecure subsidiary principally to acquire operational assets and \$0.4 million was used by our discontinued operations. During 2008, we used \$3.3 million to acquire the land and building constituting our principal executive offices and the principal offices of our PowerSecure subsidiary, \$12.8 million to purchase and install equipment at our recurring revenue distributed generation sites, \$1.5 million at our PowerSecure subsidiary principally to acquire operational assets, \$0.7 million to acquire additional equity interests in our WaterSecure operations, \$0.3 million to purchase or develop software at our PowerSecure subsidiary, and \$0.4 million was used by our discontinued operations.

Cash Provided by Financing Activities

Cash provided by financing activities was \$5.5 million, \$0.2 million and \$6.2 million in 2010, 2009 and 2008, respectively. During 2010, we borrowed \$5.0 million on our credit facility, we received \$1.3 million from the exercise of stock options and we used \$0.8 million to repay our capital lease obligations. During 2009, we received \$0.6 million from the sale and leaseback of certain recurring revenue equipment, we used \$0.7 million to repay our capital lease obligations and we received \$0.4 million from the exercise of stock options and warrants. During 2008, we received \$5.9 million from the sale and leaseback of certain recurring revenue equipment, \$2.6 million proceeds from a term loan used to finance the acquisition of the land and building constituting our principal executive offices and the principal offices of our PowerSecure subsidiary which was repaid during the year, and \$0.3 million proceeds from the exercise of stock options.

Capital Spending

Our capital expenditures during 2010 were approximately \$6.1 million, of which we used \$2.6 million to purchase and install equipment at our recurring revenue distributed generation sites, and \$3.5 million to purchase equipment and other capital items. Our capital expenditures during 2009 were approximately \$2.6 million, of which we used \$1.6 million to purchase and install equipment at our recurring revenue distributed generation sites, and \$1.0 million to purchase equipment and other capital items. Our capital expenditures during 2008 were approximately \$19.9 million, of which we used \$3.3 million to purchase acquire the land and building constituting our principal executive offices and the principal offices of our PowerSecure subsidiary in Wake Forest, North Carolina, \$12.8 million to purchase and install equipment at our recurring revenue distributed generation sites, and \$1.8 million to purchase equipment and other capital items.

We anticipate making capital expenditures of approximately \$10-15 million in 2011, although customer demand for our Interactive Distributed Generation systems under recurring revenue contract arrangements, and economic and financial conditions could cause us to reduce or increase those capital expenditures. The vast majority of our capital spending has to date been and will continue to be used for investments in assets related to our recurring revenue projects as well as equipment to support the growth of our Energy and Smart Grid Solutions segment.

Indebtedness

Line of Credit. We have had a credit facility with Citibank, as administrative agent and lender, and other lenders since entering into a credit agreement in August, 2007. At December 31, 2010, our credit agreement with Citibank, along with SunTrust Bank and BB&T as additional lenders, provided for a \$50.0 million senior, first-priority secured revolving and term credit facility. In January 2011, the credit facility was amended to facilitate the sale of our Southern Flow subsidiary, modify certain financial covenants to accommodate our financial profile after that sale and reflect a change in lenders. The credit facility, as amended, is now a \$25.0 million senior, first-priority secured revolving credit facility with Citibank and BB&T as lenders. The credit facility is guaranteed by all of our active subsidiaries and secured by all of our assets and the assets of our active subsidiaries. The following discussion of our credit facility is based upon the terms of the credit agreement as amended through the date of this report.

The credit facility, as a revolving credit facility, matures and terminates on November 12, 2013. However, we have the option prior to that maturity date to convert a portion of outstanding principal balance into a non-revolving term loan for a two year period expiring November 12, 2015, making quarterly payments based upon a four year fully amortized basis with the remaining outstandings due as a balloon payment on November 12, 2015.

We intend to continue to use the proceeds available under the credit facility to finance our distributed generation recurring revenue projects as well as to finance capital expenditures, working capital, acquisitions, and general corporate purposes. We are required, at all times until April 1, 2012, to maintain cash balances of at least 65% of our outstanding borrowings under the revolving credit facility.

Outstanding balances under the credit facility bear interest, at our discretion, at either the London Interbank Offered Rate for the corresponding deposits of U. S. Dollars plus an applicable margin, which is on a sliding scale ranging from 200 basis points to 325 basis points based upon the our leverage ratio, or at Citibank's alternate base rate plus an applicable margin, on a sliding scale ranging from 25 basis points to 150 basis points based upon our leverage ratio. Our leverage ratio is the ratio of our funded indebtedness as of a given date to our consolidated EBITDA as defined in the credit agreement for the four consecutive quarters ending on such date. Citibank's alternate base rate is equal to the higher of the Federal Funds Rate as published by the Federal Reserve of New York plus 0.50%, and Citibank's prime commercial lending rate.

The credit facility is not subject to any borrowing base computations, but does contain certain financial covenants. Our minimum asset coverage must be in excess of 1.25, where our asset coverage is defined as the summation of 80% of the book value of accounts receivable plus 60% of the book value of inventory plus 50% of the book value of net fixed assets, divided by total funded debt outstanding. In addition, we are required to maintain a minimum consolidated tangible net worth, computed on a quarterly basis, equal to approximately \$62.0 million. Finally, our debt to worth ratio, which is the ratio of our total consolidated indebtedness to our consolidated tangible net worth, cannot exceed 1.5 to 1.0 at the end of any quarter. At December 31, 2010, we were in compliance with these financial covenants. In addition, commencing March 31, 2012, our maximum leverage ratio cannot exceed 3.25 and our minimum fixed charge coverage ratio must be in excess of 1.25, where the fixed charge coverage ratio is defined as the ratio of the aggregate of our trailing 12 month consolidated EBITDA plus our lease or rent expense minus our taxes based on income and payable in cash, divided by the sum of our consolidated interest charges plus our lease or rent expenses plus our scheduled principal payments and dividends, computed over the previous period.

Under the credit facility, our cumulative capital expenditures beginning in 2008 cannot exceed the sum of \$5.0 million plus \$1.25 million per quarter, on a cumulative basis, plus an allowance for our PowerSecure subsidiary recurring revenue projects generated after December 31, 2007. The credit facility contains other representations and warranties and affirmative and negative covenants, including restrictions with respect to liens, indebtedness, loans and investments, material changes in our business, asset sales or leases or transfers of assets, restricted payments such as distributions and dividends, mergers or consolidations and transactions with affiliates.

Upon the sale of any of our assets or the assets of our subsidiaries other than in the ordinary course of business or the public or private sale of any of our equity or debt or the equity or debt of our subsidiaries other than equity issuances where the aggregate net equity proceeds do not exceed \$10.0 million, we are required to use the net proceeds thereof to repay any indebtedness then outstanding under the credit facility, except for certain reinvestment provisions.

Our obligations under the credit facility are secured by guarantees and security agreements by each of our active subsidiaries. The guarantees guaranty all of our obligations under the credit facility, and the security

agreements grant to the lenders a first priority security interest in virtually all of the assets of each of the parties to the credit agreement.

The credit agreement also contains customary events of default, including payment defaults, breach of representations and warranties, covenant defaults, cross-defaults, certain bankruptcy or insolvency events, judgment defaults and certain ERISA-related events.

The maximum balance outstanding on the credit facility during the year ended December 31, 2010 was \$10.0 million. The balance outstanding on the credit facility at December 31, 2010 was \$5.0 million, which is the same balance outstanding at March 10, 2011. At December 31, 2009, there were no balances outstanding under the credit facility. Under the amended provisions of our credit facility, we had \$20.0 million available to borrow under the credit facility at March 10, 2011. However, the availability of this capital under our credit facility includes restrictions on the use of proceeds, and is dependent upon our ability to satisfy certain financial and operating covenants, as described above.

Capital Lease Obligations. We have a capital lease with SunTrust Equipment Finance and Leasing, an affiliate of SunTrust Bank, from the sale and leaseback of distributed generation equipment placed in service at customer locations. We received \$5.9 million from the sale of the equipment in December 2008 which we are repaying under the terms of the lease with monthly principal and interest payments of \$85 over a period of 84 months. At the expiration of the term of the lease in December 2015, we have the option to purchase the equipment for \$1, assuming no default under the lease by us has occurred and is then continuing. The lease is guaranteed by us under an equipment lease guaranty. The lease and the lease guaranty constitute permitted indebtedness under our current credit agreement.

Proceeds of the lease financing were used to finance our distributed generation recurring revenue projects as well as to finance capital expenditures and working capital. We account for the lease financing as a capital lease in our consolidated financial statements in accordance with generally accepted accounting principles.

The lease provides our PowerSecure subsidiary with limited rights, subject to the lessor's approval which will not be unreasonably withheld, to relocate and substitute equipment during its term. The lease contains customary representations and warranties and covenants relating to the use and maintenance of the equipment, indemnification and events of default customary for leases of this nature. The lease also grants to the lessor certain remedies upon a default, including the right to cancel the lease, to accelerate all rent payments for the remainder of the term of the lease, to recover liquidated damages, or to repossess and re-lease, sell or otherwise dispose of the equipment.

Under the lease guaranty, we have unconditionally guaranteed the obligations of our PowerSecure subsidiary under the lease for the benefit of the lessor. Our capital lease obligations at December 31, 2010 and 2009 was \$4.4 million and \$5.2 million, respectively, and consist of our obligations under the equipment lease described above as well as various other miscellaneous lease obligations.

Restructuring Obligations. During 2007, we incurred restructuring charges for severance and associated costs related to certain organizational changes focused on accelerating our growth, and especially the growth of our Energy and Smart Grid Solutions segment. All of our restructuring obligations have been paid at December 31, 2010.

Preferred Stock Redemption. The terms of our Series B preferred stock required us to redeem all shares of our Series B preferred stock that remained outstanding on December 9, 2004 at a redemption price equal to the liquidation preference of \$1,000 per share plus accumulated and unpaid dividends. Our remaining redemption obligation at December 31, 2010, to holders of outstanding shares of Series B preferred stock that have not been redeemed, is \$0.1 million.

Contractual Obligations and Commercial Commitments

We incur various contractual obligations and commercial commitments in our normal course of business. We lease certain office space, operating facilities and equipment under long-term lease agreements; to the extent we borrow under our credit facility, we are obligated to make future payments under that facility; we have a deferred compensation obligation; and in 2009 we entered into a non-compete agreement providing for on-going payments. At December 31, 2010, we also have a liability for unrecognized tax benefits and related interest and penalties totaling \$1.7 million. We do not expect a significant payment related to these obligations within the next year and we are unable to make a reasonably reliable estimate when cash settlement with a taxing authority would occur.

Accordingly, the information in the table below, which is as of December 31, 2010, does not include the liability for unrecognized tax benefits (dollars in thousands):

	Payments Due by Period				
	Total	Less than 1 year	1 - 3 Years	4 - 5 Years	More than 5 Years
<u>Contractual Obligations</u>					
Credit facility (1)	\$ 5,000	\$ -	\$ 5,000	\$ -	\$ -
Capital lease obligations (2)	5,077	1,016	2,031	2,030	-
Operating leases	7,669	1,586	2,824	1,752	1,507
Deferred compensation (3)	2,661	-	-	-	2,661
Non-compete agreement	500	100	200	200	-
Series B preferred stock	104	104	-	-	-
Total	<u>\$ 21,011</u>	<u>\$ 2,806</u>	<u>\$ 10,055</u>	<u>\$ 3,982</u>	<u>\$ 4,168</u>

- (1) Total repayments are based upon borrowings outstanding as of December 31, 2010, not actual or projected borrowings after such date.
- (2) Repayment amounts include interest on the capital lease obligation.
- (3) Total amount represents our expected obligation on the deferred compensation arrangement and does not include the value of the restricted annuity contract, or interest earnings thereon, that we purchased to fund our obligation.

Off-Balance Sheet Arrangements

During 2010, we did not engage in any material off-balance sheet activities or have any relationships or arrangements with unconsolidated entities established for the purpose of facilitating off-balance sheet arrangements or other contractually narrow or limited purposes. Further, we have not guaranteed any obligations of unconsolidated entities nor do we have any commitment or intent to provide additional funding to any such entities.

Liquidity

Based upon our plans and assumptions as of the date of this report, we believe that our capital resources, including our cash and cash equivalents, cash proceeds from the sale of Southern Flow, amounts available under our credit facility, along with funds expected to be generated from our operations, will be sufficient to meet our anticipated cash needs, including for working capital, capital spending and debt service commitments, for at least the next 12 months. However, any projections of future cash needs and cash flows are subject to substantial risks and uncertainties. See "Cautionary Note Regarding Forward-Looking Statements" at the beginning of this report and "Item 1A. Risk Factors." Although we believe that we have sufficient capital to fund our activities for at least the next 12 months, our future cash resources and capital requirements may vary materially from those now planned. Our ability to meet our capital needs in the future will depend on many factors, including the effects of the current economic and financial crisis, the timing of sales, the mix of products, the amount of recurring revenue projects, our ability to meet our financial covenants under our credit facility, unanticipated events over which we have not control increasing our operating costs or reducing our revenues beyond our current expectations, and other factors listed under "—Fluctuations" above. For these reasons, we cannot provide any assurance that our actual cash requirements will not be greater than we currently expect or that these sources of liquidity will be available when needed.

We also continually evaluate opportunities to expand our current, or to develop new, products, services, technology and businesses that could increase our capital needs. In addition, from time to time we consider the acquisition of, or the investment in, complementary businesses, products, services and technology that might affect our liquidity requirements. We may seek to raise any needed or desired additional capital from the proceeds of public or private equity or debt offerings at the parent level or at the subsidiary level or both, from asset or business sales, from traditional credit financings or from other financing sources. In addition, we continually evaluate

opportunities to improve our credit facilities, through increased credit availability, lower debt costs or other more favorable terms. However, our ability to obtain additional capital or replace or improve our credit facilities when needed or desired will depend on many factors, including general economic and market conditions, our operating performance and investor and lender sentiment, and thus cannot be assured. In addition, depending on how it is structured, a financing could require the consent of our current lending group. Even if we are able to raise additional capital, the terms of any financings could be adverse to the interests of our stockholders. For example, the terms of a debt financing could restrict our ability to operate our business or to expand our operations, while the terms of an equity financing, involving the issuance of capital stock or of securities convertible into capital stock, could dilute the percentage ownership interests of our stockholders, and the new capital stock or other new securities could have rights, preferences or privileges senior to those of our current stockholders. We cannot provide any assurance that sufficient additional funds will be available to us when needed or desired or that, if available, such funds can be obtained on terms favorable to us and our stockholders and acceptable to those parties who must consent to the financing. Our inability to obtain sufficient additional capital on a timely basis on favorable terms when needed or desired could have a material adverse effect on our business, financial condition and results of operations.

Critical Accounting Policies

Management's discussion and analysis of our financial condition and results of operations are based on our consolidated financial statements, which have been prepared in accordance with accounting principles generally accepted in the United States of America. The preparation of these financial statements requires management to make estimates, judgments and assumptions that affect the reported amounts of assets and liabilities and disclosure of contingent assets and liabilities at the date of the financial statements and the reported amounts of revenues and expenses during the reporting period. On an on-going basis, we evaluate our estimates, including those related to revenue recognition and percentage of completion, fixed price contracts, product returns, warranty obligations, bad debt, inventories, cancellations costs associated with long term commitments, investments, intangible assets, assets subject to disposal, income taxes, restructuring, service contracts, contingencies and litigation. We base our estimates on historical experience and on various other assumptions that we believe are reasonable under the circumstances, the results of which form the basis for making estimates and judgments about the carrying value of assets and liabilities that are not readily apparent from other sources. Estimates, by their nature, are based on judgment and available information. Therefore, actual results could differ from those estimates and could have a material impact on our consolidated financial statements.

We have identified the accounting principles which we believe are most critical to understanding our reported financial results by considering accounting policies that involve the most complex or subjective decisions or assessments. These accounting policies described below include:

- revenue recognition;
- allowance for doubtful accounts;
- inventories;
- warranty reserve;
- impairment of long-lived assets;
- deferred tax valuation allowance;
- uncertain tax positions;
- costs of exit or disposal activities and similar nonrecurring charges; and
- stock-based compensation.

Further information about our significant accounting policies is included in note 1 of the notes to our consolidated financial statements contained elsewhere in this report.

Revenue Recognition. For our distributed generation turn-key project-based sales and our utility infrastructure turn-key project-based sales, we recognize revenue and profit as work progresses using the percentage-of-completion method, which relies on various estimates. We believe the use of the percentage-of-completion method of accounting for these projects is preferable to the completed contract method because these projects typically occur over several accounting periods and the percentage-of-completion method is a better method to match the revenues and costs to the reporting period in which the construction services are performed. Nearly all of these projects are fixed-price contracts, with the exception of certain contracts which provide for additional

billings based on wire usage to connect distributed generation equipment to customer facilities.

In applying the percentage-of-completion method to our distributed generation turn-key projects, we have identified the key output project phases that are standard components of these projects. We have further identified, based on past experience, an estimate of the value of each of these output phases based on a combination of costs incurred and the value added to the overall construction project. While the order of these phases varies depending on the project, each of these output phases is necessary to complete each project and each phase is an integral part of the turn-key product solution we deliver to our customers. We use these output phases and percentages to measure our progress toward completion of our construction projects. For each reporting period, the status of each project, by phase, is determined by employees who are managers of or are otherwise directly involved with the construction project and is reviewed by our accounting personnel. Utilizing this information, we recognize project revenues (and associated project costs) and gross profit based on the percentage associated with output phases that are complete or in process on each of our projects.

In applying the percentage-of-completion method to our utility infrastructure projects, revenues and gross profit are recognized as work is performed based on the relationship between actual costs incurred and total estimated costs at completion.

In all cases where we utilize the percentage-of-completion, revenues and gross profit are adjusted prospectively for revisions in estimated total contract costs and contract values. Estimated losses, if any, are recorded when identified. While a project is in process, amounts billed to customers in excess of revenues recognized to date are classified as current liabilities. Likewise, amounts recognized as revenue in excess of actual billings to date are recorded as unbilled accounts receivable. In the event adjustments are made to the contract price, including, for example, adjustments for additional wire or other raw material usage, we recognize the associated revenue when the actual costs are incurred and the customer is billed.

Because the percentage-of-completion method of accounting relies upon estimates described above, recognized revenues and profits are subject to revision as a project progresses to completion. Revisions in profit estimates are charged to income in the period in which the facts that give rise to the revision become known. In the event we were required to adjust any particular project's estimated revenues or costs, the effect on the current period earnings may or may not be significant. If, however, conditions arise that requires us to adjust our estimated revenues or costs for a series of similar construction projects, the effect on current period earnings would more likely be significant. In addition, certain contracts provide for cancellation provisions prior to completion of a project. The cancellation provisions generally provide for payment of costs incurred, but may result in an adjustment to profit already recognized in a prior period.

We recognize equipment and product revenue when persuasive evidence of a non-cancelable arrangement exists, delivery has occurred and/or services have been rendered, the price is fixed or determinable, and collectability is reasonably assured. Equipment and product sales are generally made directly to end users of the product, who are responsible for payment for the product.

Service revenue includes regulatory consulting and rate design services, power system engineering services, energy conservation services, and monitoring and maintenance services. Revenues from these services are recognized when the service is performed and the customer has accepted the work.

Additionally, our utility infrastructure business provides services to utilities involving construction, maintenance, and upgrades to their electrical transmission and distribution systems which is not fixed price project-based work. These services are delivered by us under contracts which are generally of two types. In the first type, we are paid a fixed fee based on the number of units of work we complete, an example of which is number of new utility poles we replace. In the second type, we are paid for the time and materials utilized to complete the work, plus a profit margin. In both cases, we recognize revenue as these services are delivered.

Revenues for our recurring revenue distributed generation contracts are recognized over the term of the contract, or when energy savings are realized by the customer at their site. Under these arrangements, we provide utilities and their customers with access to PowerSecure-owned and operated distributed generation systems for standby power and to deliver peak shaving benefits. These contracts can involve multiple parties, with one party paying us for the value of backup power (usually, but not always, a commercial, industrial, or institutional customer), and one party paying us for the value of the electrical capacity provided by the system (either the customer or a utility).

Sales of certain goods or services sometimes involve the provision of multiple elements. Revenues from contracts with multiple element arrangements are recognized as each element is earned based on the relative fair value of each element and when the delivered elements have value to customers on a standalone basis. Amounts allocated to each element are based on its objectively determined fair value, such as the sales price for the product or service when it is sold separately or competitor prices for similar products or services.

Allowance for Doubtful Accounts. We maintain allowances for doubtful accounts for estimated losses resulting from the inability of our customers to make required payments. We assess the customer's ability to pay based on a number of factors, including our past transaction history with the customer and the credit worthiness of the customer. Management regularly analyzes accounts receivable and historical bad debts, customer credit-worthiness, customer concentrations, current economic trends, and changes in our customer payment patterns when we evaluate the adequacy of our allowances for doubtful accounts. We estimate the collectability of our accounts receivable and establish necessary reserves on an account-by-account basis. In addition, we also provide for a general reserve for all accounts receivable. If the financial condition of our customers were to deteriorate in the future, resulting in an impairment of their ability to make payments, additional allowances may be required. In addition, since a large portion of our receivables are due from major customers or from customers for whom the project represents a major capital expenditure, significant adverse changes to the financial condition of these customers may result in significant adjustments to our allowance.

Inventories. Inventories are stated at the lower of cost (determined primarily on a specific identification basis) or market (estimated net realizable value). The vast majority of our inventory is acquired for specific projects; a smaller portion of our inventory is acquired to assemble component parts for use in later assemblies; and a portion of our inventory consists of spare parts and supplies that we maintain to support a full-product range and a wide variety of customer requirements. The portion of our inventory acquired for specific projects tends to be high-dollar value quick turnaround equipment items. The portion of our inventory used to assemble component parts tends to be comprised of electronic parts, which may be subject to obsolescence or quality issues. The portion of our inventory that supports older product lines and other customer requirements may also be slow-moving and subject to potential obsolescence due to product lifecycle and product development plans.

We perform periodic assessments of inventory that includes a review of quantities on hand, component demand requirements, product lifecycle and product development plans, and quality issues. As a result of this assessment, we write-down inventory for estimated losses due to obsolescence, scrap, theft and unmarketability equal to the difference between the cost of the inventory and the estimated market value based on assumptions and estimates concerning future demand, market conditions and similar factors. If actual demand and market conditions are less favorable than those estimated by management, additional inventory write-downs may be required.

Warranty Reserve. We provide a standard warranty for our distributed generation equipment, switchgear equipment, utility infrastructure equipment, and for our Energy Efficiency unit's lighting products, which range generally between one and five years. In addition, we offer extended warranty terms on our distributed generation turn-key and switchgear projects. We reserve for the estimated cost of product warranties when revenue is recognized, and we evaluate our reserve periodically by comparing our warranty repair experience by product. The purchase price for extended warranties or extended warranties included in the contract terms are deferred as a component of our warranty reserve. While we engage in product quality programs and processes, including monitoring and evaluating the quality of our components suppliers, our warranty obligation is affected by actual product failure rates, parts and equipment costs and service labor costs incurred in correcting a product failure. In addition, our operating history in the distributed generation, switchgear, and LED-lighting markets are limited. Should actual product failure rates, parts and equipment costs, or service labor costs differ from our estimates, revisions to the estimated warranty liability would be required. The following table summarizes our warranty reserves for the periods indicated (dollars in thousands):

	Balance at January 1	Reserve Additions	Utilized/ Deductions	Balance at December 31
2008	\$ 421	\$ 326	\$ (50)	\$ 697
2009	697	109	(37)	769
2010	769	380	(62)	1,087

Impairment of Long-Lived Assets. Long-lived assets, such as property and equipment, goodwill and intangible assets, are reviewed for impairment at least annually or whenever events or changes in circumstances

indicate that the carrying amount of an asset may not be recoverable. All of our identifiable intangible assets are amortized using the straight-line method. In assessing the recoverability of goodwill and intangible assets, we use estimates of future cash flows and other factors to determine the fair value of these assets. For intangible assets, our evaluation includes an analysis of estimated future undiscounted net cash flows expected to be generated by the assets over their estimated useful lives. If the estimated future undiscounted net cash flows are insufficient to recover the carrying value of the assets over their estimated useful lives, we will record an impairment charge in the amount by which the carrying value of the assets exceeds their fair value. For goodwill, our impairment evaluation includes a comparison of the carrying value of the reporting unit which carries the goodwill to that reporting unit's fair value. The fair value of each reporting unit is based upon an estimate of the net present value of future cash flows, as well as other valuation techniques. If the reporting unit's estimated fair value exceeds the reporting unit's carrying value, no impairment of goodwill exists. If the fair value of the reporting unit does not exceed its carrying value, then further analysis is required to determine the amount of goodwill impairment, if any. We completed our most recent annual testing of the impairment of goodwill as of October 1, 2010. As a result of the test, we concluded that no impairment of goodwill existed as of October 1, 2010.

In the event future cash flows are adversely affected by events or circumstances, such as by significant changes in current technologies or significant changes in market conditions in the distributed generation, utility or energy efficiency industries, then future valuations of our goodwill and other intangible assets may result in future impairment charges, and those charges may be significant.

Deferred Tax Valuation Allowance. In assessing the need for a valuation allowance, we consider all positive and negative evidence, including scheduled reversals of deferred tax liabilities, projected future taxable income, tax planning strategies, and recent financial performance. We currently record a valuation allowance for a significant portion of our deferred tax assets, with the exception of a portion of our deferred tax asset for federal and state net operating loss carryforwards which we expect to utilize in the reasonably foreseeable future. In the event we were to determine that we would be able to realize deferred tax assets in the future in excess of our net recorded amount, an adjustment to the valuation allowance would increase the income in the period such determination was made. Likewise, in the future, should we have a net deferred tax asset and determine that we would not be able to realize all or part of that asset, an adjustment to the valuation allowance would be charged to income in the period that such determination was made. Once we utilize our net operating loss carryforwards, we would expect our provision for income tax expense in future periods to reflect an effective tax rate that will be significantly higher than in prior periods.

Uncertain Tax Positions. The process of filing federal and state income tax returns requires us, in consultation with our tax advisors, to make judgments regarding how we will apply intricate and often ambiguous laws, regulations, administrative rulings and court precedents. From time to time we undergo audits by federal, state, and local taxing authorities, and these judgments may be questioned or disallowed in total or in part. As a result, when determining the accounting entries necessary to accurately reflect income taxes currently payable and/or refundable, we must make assumptions regarding the likelihood of success in defending our judgments in the event of audits.

We have recorded a liability for our estimate of taxes, penalties and interest associated with uncertain tax positions. Our estimate is based on assumptions regarding the likelihood of successfully defending this tax position in an audit. We utilize a two-step approach to recognizing and measuring uncertain tax positions. The first step is to evaluate the tax position for recognition by determining if the weight of available evidence indicates that it is more likely than not that the position will be sustained on audit, including resolution of related appeals or litigation processes, if any. The second step is to measure the tax benefit as the largest amount that is more than 50% likely of being realized upon settlement.

Although we believe we have adequately reserved for our uncertain tax positions, no assurance can be given that the final tax outcome of these matters will not be different. We adjust these reserves in light of changing facts and circumstances, such as the closing of a tax audit or the refinement of an estimate. To the extent that the final tax outcome of these matters is different than the amounts recorded, such differences will impact the provision for income taxes in the period in which such determination is made. The provision for income taxes includes the impact of reserve provisions and changes to reserves that are considered appropriate, as well as the related net interest.

The application of tax laws and regulations is subject to legal and factual interpretation, judgment and uncertainty. Tax laws and regulations themselves are subject to change as a result of changes in fiscal policy, changes in legislation, the evolution of regulations and court rulings. Therefore, the actual liability for U.S. or

foreign taxes may be materially different from our estimates, which could result in the need to record additional tax liabilities or potentially reverse previously recorded tax liabilities.

Costs of Exit or Disposal Activities and Similar Nonrecurring Charges. We record a liability for costs associated with exit or disposal activities equal to the fair value of the liability when the liability is incurred. Such costs associated with a discontinued operation are reported in results of discontinued operations. Costs of an exit or disposal activity that do not involve a discontinued operation are included in income from continuing operations before income taxes in our consolidated statement of operations.

Share-Based Compensation. We measure compensation cost for all stock-based awards at the fair value on date of grant and recognize the compensation expense over the service period for awards expected to vest. We measure the fair value of restricted stock awards based on the number of shares granted and the quoted price of our common stock on the date of the grant, and we measure the fair value of stock options using the Black-Scholes valuation model. These fair values are recognized as compensation expense over the service period, net of estimated forfeitures.

Pre-tax share-based compensation expense for our stock options and restricted stock awards recognized during the years ended December 31, 2010, 2009 and 2008 was \$1,942, \$2,123 and \$2,384, respectively, and is included in general and administrative expense in the accompanying consolidated statements of operations.

Stock Option Expense

Net income for the years ended December 31, 2010, 2009 and 2008 includes \$381, \$556 and \$656, respectively, of pre-tax compensation costs related to outstanding stock options. The after-tax compensation cost of outstanding stock options for the years ended December 31, 2010, 2009 and 2008 was \$232, \$339 and \$400, respectively. All of the stock option compensation expense is included in general and administrative expenses in the accompanying consolidated statements of operations.

Restricted Stock Awards

Net income for the years ended December 31, 2010, 2009 and 2008 includes \$1,561, \$1,567 and \$1,728, respectively, of pre-tax compensation costs related to outstanding restricted stock awards granted to directors, certain officers and our employees. All of the restricted stock award compensation expense during the years ended December 31, 2010, 2009 and 2008 is included in general and administrative expenses in the accompanying consolidated statements of operations. In December 2009, our Board of Directors amended certain restricted stock agreements to modify the vesting conditions for 193,500 unvested performance-based restricted shares related to fiscal 2009, 2010 and 2011 in order to reflect new performance goals that are more appropriate for those years under conditions and circumstances of the Company and the economy.

Restricted shares are subject to forfeiture and cannot be sold or otherwise transferred until they vest. If the holder of the restricted shares leaves us before the restricted shares vest, other than due to termination by us without cause, then any unvested restricted shares will be forfeited and returned to us. The restricted shares granted to directors vest in equal amounts over a period of one or three years, depending on the nature of the grant. The restricted shares granted to employees other than officers vest in equal annual amounts over five years. A total of 322,500 unvested restricted shares issued to officers cliff vest in 2012, while the remaining 129,000 unvested performance-based restricted shares issued to officers vest in equal annual amounts in 2011 and 2012, assuming certain performance conditions are achieved. All restricted and unvested shares will automatically vest upon a change in control.

The fair value of employee and director restricted shares along with the cliff vesting restricted shares granted to officers are being amortized on a straight-line basis over the vesting period. The fair value of the performance-based restricted shares is expensed as the achievement of the performance criteria becomes probable and the related service period conditions are met. At December 31, 2010, the balance of unrecognized compensation cost related to unvested restricted shares was \$1,999, which, assuming all future performance criteria will be met, we expect will be recognized over a weighted average period of approximately 1.5 years.

Recent Accounting Pronouncements

Revenue Recognition—Milestone Method—In April 2010, the FASB issued Accounting Standards Update (“ASU”) No. 2010-17 – *Revenue Recognition - Milestone Method (Topic 605): Milestone Method of Revenue Recognition*. This standard provides guidance on defining a milestone and determining when it may be appropriate to apply the milestone method of revenue recognition for certain research and development transactions. Under this new standard, a company can recognize as revenue consideration that is contingent upon achievement of a milestone in the period in which it is achieved, only if the milestone meets all criteria to be considered substantive. This standard will be effective for us on a prospective basis beginning January 1, 2011. We have evaluated the potential impact of this standard and expect it will have no significant impact on our financial position or results of operations.

Improving Disclosures about Fair Value Measurements—In January 2010, the FASB issued ASU No. 2010-06 – *Fair Value Measurements and Disclosures (Topic 820): Improving Disclosures about Fair Value Measurements*. This standard amends the disclosure guidance with respect to fair value measurements for both interim and annual reporting periods. Specifically, this standard requires new disclosures for significant transfers of assets or liabilities between Level 1 and Level 2 in the fair value hierarchy; separate disclosures for purchases, sales, issuance and settlements of Level 3 fair value items on a gross, rather than net basis; and more robust disclosure of the valuation techniques and inputs used to measure Level 2 and Level 3 assets and liabilities. Except for the detailed disclosures of changes in Level 3 items, which will be effective for us as of January 1, 2011, the remaining new disclosure requirements were effective for us as of January 1, 2010. The adoption of the new guidance on January 1, 2010 had no effect on our financial position or results of operations or on our financial statement disclosures.

Multiple Deliverable Revenue Arrangements—In October 2009, the FASB issued ASU No. 2009-13 – *Multiple Deliverable Revenue Arrangements – A Consensus of the FASB Emerging Issues Task Force: (Topic 605) Revenue Recognition*. ASU No. 2009-13 provides application guidance on whether multiple deliverables exist, how the deliverables should be separated and how the consideration should be allocated to one or more units of accounting. This update establishes a selling price hierarchy for determining the selling price of a deliverable. The selling price used for each deliverable will be based on vendor-specific objective evidence, if available, third-party evidence if vendor-specific objective evidence is not available, or estimated selling price if neither vendor-specific or third-party evidence is available. We will be required to apply the new guidance prospectively for revenue arrangements entered into or materially modified after January 1, 2011; however, early application is permitted. We have evaluated the potential impact of this standard and expect it will have no significant impact on our financial position or results of operations.

Item 7A. Quantitative and Qualitative Disclosures About Market Risk

We are exposed to certain market risks arising from transactions we enter into in the ordinary course of business. These market risks are primarily due to changes in interest rates and commodity prices, which may adversely affect our financial condition, results of operations and cash flow.

Interest Rate Risk. Our exposure to market risk resulting from changes in interest rates relates primarily to income from our investments in short-term interest-bearing marketable securities, which is dependent upon the interest rate of the securities held, and to interest expenses attributable to our credit facility, which is based on floating interest rates as described in "Item 7. Management's Discussion and Analysis of Financial Condition and Results of Operations" of this report. Our lease with SunTrust is at a fixed interest rate and thus not impacted by changes in interest rates.

At December 31, 2010, our cash and cash equivalent balance was approximately \$8.2 million and we had an outstanding balance on our credit facility of \$5.0 million. Subsequent to December 31, 2010, we received approximately \$16.5 million in gross cash proceeds from the sale of Southern Flow. Our cash equivalents are invested in a combination of bank deposits, money market or U.S. government mutual funds, short-term time deposits, and government agency and corporate obligations, or similar kinds of instruments, the income of which generally increases or decreases in proportion to increases or decreases, respectively, in interest rates. We do not believe that changes in interest rates have had a material impact on us in the past or are likely to have a material impact on us in the foreseeable future. For example, a change of 1% (100 basis points) in the interest rate on either our investments or any future reasonably likely borrowings would not have a material impact on our financial condition, results of operations or cash flow. While we believe we have our cash and cash equivalents invested in relatively risk-free investments, the current capital market crisis make it difficult to accurately assess the risk of each of our holdings. This risk includes, but is not limited to, bank deposits in excess of FDIC insurance limits.

Commodity Price Risk. From time to time we are subject to market risk from fluctuating commodity prices in certain raw materials we use in our products and diesel fuel we use to power our generators. To date, in our Energy and Smart Grid Solutions segment, we have managed this risk by using alternative raw materials acceptable to our customers or we have been able to pass these cost increases to our customers. While we do not believe that changes in commodity prices have had a material impact on us in the past, commodity price fluctuations could have a material impact on us in the future, depending on the magnitude and timing of such fluctuations. The impact of these fluctuations could result in an increase in our operating costs and expenses and reduction in our gross margins and income due to increases in the price and costs of engines, generators, copper, aluminum, electrical components, labor, electricity, diesel fuel, gasoline, oil and natural gas. In our Energy Services segment, we have on-going commodity price risk primarily related to the price of oil and natural gas. Movements in prices of these commodities can materially impact our results in this segment.

Foreign Exchange Risk. Since substantially all of our revenues, expenses and capital spending are transacted in U.S. dollars, we face minimal exposure to adverse movements in foreign currency exchange rates. However, as our international operations expand in the future as we expect, then our exposure to foreign currency risks will increase, which could affect our business and our results of operations. In addition, because our EfficientLights business purchases component parts manufactured in China, then to the extent the U.S. Dollar exchange rate with the Chinese Yuan changes significantly, our business and results of operations could be materially impacted.

We do not use derivative financial instruments to manage or hedge our exposure to interest rate changes, foreign currency exchange risks or other market risks, or for trading or other speculative purposes.

Item 8. Financial Statements and Supplementary Data

The information required by this item is set forth commencing on pages F-1 and G-1 of this report.

Item 9. Changes in and Disagreements with Accountants on Accounting and Financial Disclosure

None.

Item 9A. Controls and Procedures

Evaluation of Disclosure Controls and Procedures

Our management, with the participation of our Chief Executive Officer and our Chief Financial Officer, evaluated the effectiveness of our disclosure controls and procedures, as defined in Rules 13a-15(e) and 15d-15(e) under the Exchange Act, as of December 31, 2010, the end of the period covered by this report. Based upon this evaluation, our Chief Executive Officer and our Chief Financial Officer concluded that, as of December 31, 2010, our disclosure controls and procedures were designed at a reasonable assurance level and were effective at a reasonable assurance level to provide reasonable assurance that information we are required to disclose in reports that we file or submit under the Exchange Act is recorded, processed, summarized and reported within the time periods specified in the SEC's rules and forms, and that such information is accumulated and communicated to management, including our Chief Executive Officer and our Chief Financial Officer, as appropriate to allow timely decisions regarding required disclosure.

Changes in Internal Control Over Financial Reporting

We regularly review our system of internal control over financial reporting and make changes to our processes and systems to improve controls and increase efficiency, while ensuring that we maintain an effective internal control environment. Changes may include such activities as implementing new, more efficient systems, consolidating activities and migrating processes.

There were no changes in our internal control over financial reporting, as defined in Rules 13a-15(f) and 15d-15(f) under the Exchange Act, that occurred during the quarter ended December 31, 2010 that have materially affected, or are reasonably likely to materially affect, our internal control over financial reporting.

Management's Report on Internal Control Over Financial Reporting

Our management is responsible for establishing and maintaining adequate internal control over financial reporting, as defined in Rules 13a-15(f) and 15d-15(f) under the Exchange Act. Management conducted an evaluation of the effectiveness of our internal control over financial reporting as of December 31, 2010, based on the framework in *Internal Control--Integrated Framework* issued by the Committee of Sponsoring Organizations of the Treadway Commission. Based on this evaluation, management concluded that our internal control over financial reporting was effective as of December 31, 2010. Management reviewed the results of its assessment with our Audit Committee. The effectiveness of our internal control over financial reporting as of December 31, 2010 has been audited by Hein & Associates LLP, an independent registered public accounting firm, as stated in its report which is included below in this item.

Limitations in Control Systems

Our controls and procedures were designed at a reasonable assurance level. In designing and evaluating our controls and procedures, management recognizes that, because of inherent limitations, any system of controls and procedures, no matter how well designed and operated, can provide only reasonable, not absolute, assurance of achieving the desired objectives of the control system. In addition, the design of a control system must reflect the fact that there are resource constraints, and management must apply its judgment in evaluating the benefits of possible controls relative to their costs. Further, no evaluation of controls and procedures can provide absolute assurance that all errors, control issues and instances of fraud will be prevented or detected. Controls can also be circumvented by the individual acts of some persons, by collusion of two or more people, or by management override of the controls. The design of any system of controls and procedures is also based in part on certain assumptions regarding the likelihood of future events, and there can be no assurance that any design will succeed in achieving its stated goals under all potential future conditions.

REPORT OF INDEPENDENT REGISTERED PUBLIC ACCOUNTING FIRM

To the Board of Directors and Stockholders
PowerSecure International, Inc.

We have audited PowerSecure International, Inc.'s (the "Company's") internal control over financial reporting as of December 31, 2010, based on criteria established in *Internal Control—Integrated Framework* issued by the Committee of Sponsoring Organizations of the Treadway Commission. The Company's management is responsible for maintaining effective internal control over financial reporting and for its assessment of the effectiveness of internal control over financial reporting included in the accompanying *Management's Report on Internal Control Over Financial Reporting*. Our responsibility is to express an opinion the company's internal control over financial reporting based on our audit.

We conducted our audit in accordance with the standards of the Public Company Accounting Oversight Board (United States). Those standards require that we plan and perform the audit to obtain reasonable assurance about whether effective internal control over financial reporting was maintained in all material respects. Our audit included obtaining an understanding of internal control over financial reporting, assessing the risk that a material weakness exists, and testing and evaluating the design and operating effectiveness of internal control based on the assessed risk. Our audit also included performing such other procedures as we considered necessary in the circumstances. We believe that our audit provides a reasonable basis for our opinion.

A company's internal control over financial reporting is a process designed to provide reasonable assurance regarding the reliability of financial reporting and the preparation of financial statements for external purposes in accordance with generally accepted accounting principles. A company's internal control over financial reporting includes those policies and procedures that (a) pertain to the maintenance of records that, in reasonable detail, accurately and fairly reflect the transactions and dispositions of the assets of the company; (b) provide reasonable assurance that transactions are recorded as necessary to permit preparation of financial statements in accordance with generally accepted accounting principles, and that receipts and expenditures of the company are being made only in accordance with authorizations of management and directors of the company; and (c) provide reasonable assurance regarding prevention or timely detection of unauthorized acquisition, use, or disposition of the company's assets that could have a material effect on the financial statements.

Because of its inherent limitations, internal control over financial reporting may not prevent or detect misstatements. Also, projections of any evaluation of effectiveness to future periods are subject to the risk that controls may become inadequate because of changes in conditions, or that the degree of compliance with the policies or procedures may deteriorate.

In our opinion, PowerSecure International, Inc. maintained, in all material respects, effective internal control over financial reporting as of December 31, 2010, based on the criteria established in *Internal Control—Integrated Framework* issued by the Committee of Sponsoring Organizations of the Treadway Commission.

We have also audited, in accordance with the standards of the Public Company Oversight Board (United States), the consolidated financial statements of PowerSecure International, Inc. and our report dated March 10, 2011 expressed an unqualified opinion.

/s/ HEIN & ASSOCIATES LLP

Denver, Colorado
March 10, 2011

Item 9B. Other Information

None.

PART III

Item 10. Directors, Executive Officers and Corporate Governance

The information required by this item concerning our executive officers is set forth under the heading "Executive Officers of the Registrant" in Item 1 of Part I of this report.

The remainder of the information required by this item is incorporated herein by reference to the information appearing in our definitive Proxy Statement for our 2011 Annual Meeting of Stockholders, which we will file with the SEC not later than 120 days after the end of our fiscal year ended December 31, 2010.

Item 11. Executive Compensation

The information required by this item is incorporated herein by reference to the information appearing in our definitive Proxy Statement for our 2011 Annual Meeting of Stockholders, which we will file with the SEC not later than 120 days after the end of our fiscal year ended December 31, 2010.

Item 12. Security Ownership of Certain Beneficial Owners and Management and Related Stockholder Matters

The information required by this item is incorporated herein by reference to the information appearing in our definitive Proxy Statement for our 2011 Annual Meeting of Stockholders, which we will file with the SEC not later than 120 days after the end of our fiscal year ended December 31, 2010.

Item 13. Certain Relationships and Related Transactions, and Director Independence

The information required by this item is incorporated herein by reference to the information appearing in our definitive Proxy Statement for our 2011 Annual Meeting of Stockholders, which we will file with the SEC not later than 120 days after the end of our fiscal year ended December 31, 2010.

Item 14. Principal Accounting Fees and Services

The information required by this item is incorporated herein by reference to the information appearing in our definitive Proxy Statement for our 2011 Annual Meeting of Stockholders, which we will file with the SEC not later than 120 days after the end of our fiscal year ended December 31, 2010.

PART IV

Item 15. Exhibits, Financial Statement Schedules

(a) We have filed the following documents as part of this Annual Report on Form 10-K:

1. *Financial Statements*

The following consolidated financial statements of PowerSecure International, Inc. are included commencing on page F-1 of this report:

Report of Independent Registered Public Accounting Firm
Consolidated Balance Sheets as of December 31, 2010 and 2009
Consolidated Statements of Operations for the Years Ended December 31, 2010, 2009 and 2008
Consolidated Statements of Stockholders' Equity for the Years Ended December 31, 2010, 2009 and 2008
Consolidated Statements of Cash Flows for the Years Ended December 31, 2010, 2009 and 2008
Notes to Consolidated Financial Statements

The following consolidated financial statements of Marcum Midstream 1995-2 Business Trust are included commencing on page G-1 of this report:

Report of Independent Registered Public Accounting Firm
Consolidated Balance Sheets as of December 31, 2010 and 2009
Consolidated Statements of Income for the Years Ended December 31, 2010, 2009 and 2008
Consolidated Statements of Shareholders' Equity for the Years Ended December 31, 2010, 2009 and 2008
Consolidated Statements of Cash Flows for the Years Ended December 31, 2010, 2009 and 2008
Notes to Consolidated Financial Statements

2. *Financial Statement Schedules*

The following financial statement schedule is filed as a part of this report:

Schedule II - Valuation and Qualifying Accounts

All other financial statement schedules have been omitted because they are not applicable or required or because the required information is presented in our consolidated financial statements and notes thereto.

3. *Exhibits*

The exhibits required by this item are listed on the Exhibit Index immediately following the signature page of this report.

(b) **Item 601 Exhibits**

The exhibits required by this item are listed on the accompanying Exhibit Index immediately following the signature page of this report.

(c) **Financial Statement Schedules**

The financial statement schedules required by this item are listed under Item 15(a)(2) of this report, above.

POWERSECURE INTERNATIONAL, INC. AND SUBSIDIARIES
INDEX TO CONSOLIDATED FINANCIAL STATEMENTS

	<u>Page</u>
Report of Independent Registered Public Accounting Firm	F-2
Consolidated Balance Sheets as of December 31, 2010 and 2009	F-3
Consolidated Statements of Operations for the Years Ended December 31, 2010, 2009 and 2008	F-5
Consolidated Statements of Stockholders' Equity for the Years Ended December 31, 2010, 2009 and 2008	F-6
Consolidated Statements of Cash Flows for the Years Ended December 31, 2010, 2009 and 2008	F-7
Notes to Consolidated Financial Statements	F-8

REPORT OF INDEPENDENT REGISTERED PUBLIC ACCOUNTING FIRM

Board of Directors and Stockholders
PowerSecure International, Inc.

We have audited the accompanying consolidated balance sheets of PowerSecure International, Inc. and subsidiaries (the "Company") as of December 31, 2010 and 2009, and the related consolidated statements of operations, stockholders' equity, and cash flows for each of the three years in the period ended December 31, 2010. Our audits also included the financial statement schedule of PowerSecure International, Inc. listed in Item 15. These financial statements and financial statement schedule are the responsibility of the Company's management. Our responsibility is to express an opinion on these financial statements based on our audits.

We conducted our audits in accordance with the standards of the Public Company Accounting Oversight Board (United States). Those standards require that we plan and perform the audits to obtain reasonable assurance about whether the financial statements are free of material misstatement. An audit includes examining, on a test basis, evidence supporting the amounts and disclosures in the financial statements. An audit also includes assessing the accounting principles used and significant estimates made by management, as well as evaluating the overall financial statement presentation. We believe that our audits provide a reasonable basis for our opinion.

In our opinion, the consolidated financial statements referred to above present fairly, in all material respects, the financial position of PowerSecure International, Inc. and subsidiaries as of December 31, 2010 and 2009, and the results of their operations and their cash flows for each of the three years in the period ended December 31, 2010, in conformity with U.S. generally accepted accounting principles. Also, in our opinion, the related financial statement schedule, when considered in relation to the basic consolidated financial statements taken as a whole, presents fairly in all material respects the information set forth therein.

We also have audited, in accordance with the standards of the Public Company Accounting Oversight Board (United States), PowerSecure International, Inc.'s and subsidiaries' internal control over financial reporting as of December 31, 2010, based on criteria established in *Internal Control—Integrated Framework* issued by the Committee of Sponsoring Organizations of the Treadway Commission, and our report dated March 10, 2011 expressed an unqualified opinion on the effectiveness of PowerSecure International, Inc.'s internal control over financial reporting.

HEIN & ASSOCIATES LLP

Denver, Colorado
March 10, 2011

POWERSECURE INTERNATIONAL, INC. AND SUBSIDIARIES
CONSOLIDATED BALANCE SHEETS
(in thousands, except share data)

Assets	December 31,	
	2010	2009
Current Assets:		
Cash and cash equivalents	\$ 8,202	\$ 20,169
Trade receivables, net of allowance for doubtful accounts of \$415 and \$299, respectively	29,290	28,332
Assets of discontinued operations held for sale	12,183	-
Inventories	25,011	21,632
Current deferred income taxes	1,731	1,691
Prepaid expenses and other current assets	933	1,300
Total current assets	77,350	73,124
Property, plant and equipment:		
Equipment	24,946	22,252
Furniture and fixtures	280	671
Land, building and improvements	5,720	4,802
Total property, plant and equipment, at cost	30,946	27,725
Less accumulated depreciation and amortization	5,899	5,413
Property, plant and equipment, net	25,047	22,312
Other assets:		
Goodwill	7,970	7,256
Deferred income taxes, net of current portion	1,244	1,022
Restricted annuity contract	2,306	2,220
Intangible rights and capitalized software costs, net of accumulated amortization of \$2,463 and \$1,890, respectively	1,942	1,320
Investment in unconsolidated affiliate	4,346	3,974
Other assets	324	249
Total other assets	18,132	16,041
Total Assets	\$ 120,529	\$ 111,477

See accompanying notes to consolidated financial statements.

POWERSECURE INTERNATIONAL, INC. AND SUBSIDIARIES
CONSOLIDATED BALANCE SHEETS
(in thousands, except share data)

Liabilities and Stockholders' Equity	December 31,	
	2010	2009
Current liabilities:		
Accounts payable	\$ 8,438	\$ 4,116
Accrued and other liabilities	10,986	20,379
Liabilities of discontinued operations held for sale	1,411	-
Restructuring charges payable	-	325
Current income taxes payable	251	-
Current unrecognized tax benefit	954	327
Current portion of capital lease obligations	796	756
Total current liabilities	22,836	25,903
Long-term liabilities:		
Revolving line of credit	5,000	-
Capital lease obligations, net of current portion	3,647	4,445
Unrecognized tax benefit, net of current portion	749	1,169
Deferred compensation	1,053	721
Total long-term liabilities	10,449	6,335
Commitments and contingencies (Notes 9 and 10)	-	-
Stockholders' Equity:		
PowerSecure International stockholders' equity:		
Preferred stock - undesignated, \$.01 par value; 2,000,000 shares authorized; none issued and outstanding	-	-
Preferred stock - Series C, \$.01 par value; 500,000 shares authorized; none issued and outstanding	-	-
Common stock, \$.01 par value; 25,000,000 shares authorized; 18,701,614 and 17,241,650 shares issued and outstanding, respectively	187	172
Additional paid-in-capital	114,791	110,911
Accumulated deficit	(29,489)	(32,951)
Total PowerSecure International, Inc. stockholders' equity	85,489	78,132
Noncontrolling interest	1,755	1,107
Total stockholders' equity	87,244	79,239
Total Liabilities and Stockholders' Equity	\$ 120,529	\$ 111,477

See accompanying notes to consolidated financial statements.

POWERSECURE INTERNATIONAL, INC. AND SUBSIDIARIES
CONSOLIDATED STATEMENTS OF OPERATIONS
(in thousands, except per share data)

	Year Ended December 31,		
	2010	2009	2008
Revenues	\$ 97,514	\$ 85,426	\$ 115,993
Cost of sales	62,220	54,231	77,550
Gross profit	<u>35,294</u>	<u>31,195</u>	<u>38,443</u>
Operating expenses:			
General and administrative	29,339	24,169	27,128
Selling, marketing and service	5,154	3,927	5,325
Depreciation and amortization	<u>2,754</u>	<u>2,144</u>	<u>1,847</u>
Total operating expenses	<u>37,247</u>	<u>30,240</u>	<u>34,300</u>
Operating income (loss)	(1,953)	955	4,143
Other income and (expenses):			
Equity income from unconsolidated affiliate	3,182	2,167	3,490
Management fees	583	447	556
Interest income and other income	99	161	464
Interest expense	<u>(619)</u>	<u>(607)</u>	<u>(287)</u>
Income before income taxes	1,292	3,123	8,366
Income tax provision	<u>(526)</u>	<u>(331)</u>	<u>(729)</u>
Income from continuing operations	<u>766</u>	<u>2,792</u>	<u>7,637</u>
Discontinued operations (Note 5):			
Income from operations, net of tax	2,543	1,513	3,063
Gain (loss) on disposal, net of tax	<u>-</u>	<u>-</u>	<u>(42)</u>
Income from discontinued operations, net of tax	<u>2,543</u>	<u>1,513</u>	<u>3,021</u>
Net income	3,309	4,305	10,658
Less: Net (income) loss attributable to noncontrolling interest	<u>153</u>	<u>(1,512)</u>	<u>-</u>
Net income attributable to PowerSecure International, Inc.	<u>\$ 3,462</u>	<u>\$ 2,793</u>	<u>\$ 10,658</u>
Basic earnings per share attributable to PowerSecure International, Inc. common stockholders:			
Income from continuing operations	\$ 0.05	\$ 0.07	\$ 0.45
Income from discontinued operations	<u>0.14</u>	<u>0.09</u>	<u>0.18</u>
Net income attributable to PowerSecure International, Inc. common stockholders	<u>\$ 0.19</u>	<u>\$ 0.16</u>	<u>\$ 0.63</u>
Diluted earnings per share attributable to PowerSecure International, Inc. common stockholders:			
Income from continuing operations	\$ 0.05	\$ 0.07	\$ 0.44
Income from discontinued operations	<u>0.14</u>	<u>0.09</u>	<u>0.18</u>
Net income attributable to PowerSecure International, Inc. common stockholders	<u>\$ 0.19</u>	<u>\$ 0.16</u>	<u>\$ 0.62</u>
Amounts attributable to PowerSecure International, Inc. common stockholders:			
Income from continuing operations, net of tax	\$ 919	\$ 1,280	\$ 7,637
Income from discontinued operations, net of tax	<u>2,543</u>	<u>1,513</u>	<u>3,021</u>
Net income	<u>\$ 3,462</u>	<u>\$ 2,793</u>	<u>\$ 10,658</u>

See accompanying notes to consolidated financial statements.

POWERSECURE INTERNATIONAL, INC. AND SUBSIDIARIES

CONSOLIDATED STATEMENTS OF STOCKHOLDERS' EQUITY

YEARS ENDED DECEMBER 31, 2010, 2009 AND 2008

(in thousands)

	Common Stock		Additional Paid-In Capital	Accumulated Deficit	Non- Controlling Interest	Total
	Shares	Value				
Balance at January 1, 2008	16,861	\$ 169	\$ 105,473	\$ (46,402)	\$ -	\$ 59,240
Net income				10,658		10,658
Stock option compensation			657			657
Issuance and amortization of restricted stock awards	42	-	1,492			1,492
Stock option exercises, including tax benefit of \$263	<u>169</u>	<u>2</u>	<u>762</u>			<u>764</u>
Balance at December 31, 2008	17,072	171	108,384	(35,744)	-	72,811
Net income				2,793		2,793
Noncontrolling interest:						
Share of income					1,512	1,512
Cash distributions					(405)	(405)
Stock option compensation			555			555
Issuance and amortization of restricted stock awards	15	-	1,473			1,473
Stock warrant and option exercises, including tax benefit of \$48	<u>155</u>	<u>1</u>	<u>499</u>			<u>500</u>
Balance at December 31, 2009	17,242	172	110,911	(32,951)	1,107	79,239
Net income				3,462		3,462
Noncontrolling interest:						
Capital contribution					2,188	2,188
Acquisition of noncontrolling interest	1,025	10	492		(510)	(8)
Share of income (loss)					(153)	(153)
Cash distributions					(877)	(877)
Stock option compensation			381			381
Issuance and amortization of restricted stock awards	-	-	1,378			1,378
Stock option exercises, including tax benefit of \$177	<u>435</u>	<u>5</u>	<u>1,629</u>			<u>1,634</u>
Balance at December 31, 2010	<u>18,702</u>	<u>\$ 187</u>	<u>\$ 114,791</u>	<u>\$ (29,489)</u>	<u>\$ 1,755</u>	<u>\$ 87,244</u>

See accompanying notes to consolidated financial statements.

POWERSECURE INTERNATIONAL, INC. AND SUBSIDIARIES

CONSOLIDATED STATEMENTS OF CASH FLOWS

(in thousands)

	Year Ended December 31,		
	2010	2009	2008
Cash flows from operating activities:			
Net income	\$ 3,309	\$ 4,305	\$ 10,658
Adjustments to reconcile net income to net cash provided by (used in) operating activities:			
Income from discontinued operations	(2,543)	(1,513)	(3,021)
Depreciation and amortization	2,754	2,144	1,847
Stock compensation expense	2,119	2,171	2,647
Distributions to noncontrolling shareholder	(877)	(405)	-
Deferred income taxes	(262)	206	(390)
Loss on disposal of miscellaneous assets	41	27	209
Equity in income of unconsolidated affiliate	(3,182)	(2,167)	(3,490)
Distributions from unconsolidated affiliate	2,737	2,224	3,678
Changes in operating assets and liabilities, net of effect of acquisitions:			
Trade receivables, net	(4,037)	(3,116)	11,538
Inventories	(5,280)	(1,592)	1,361
Other current assets and liabilities	468	198	(30)
Other noncurrent assets	(62)	89	(180)
Accounts payable	3,840	(1,701)	(5,505)
Restructuring charges	(325)	(1,379)	(4,027)
Accrued and other liabilities	(8,631)	(2,715)	(12,063)
Unrecognized tax benefits	207	627	110
Deferred compensation obligation	332	333	333
Restricted annuity contract	(86)	(87)	(132)
Net cash provided by (used in) continuing operations	(9,478)	(2,351)	3,543
Net cash provided by discontinued operations	2,840	1,737	4,904
Net cash provided by (used in) operating activities	<u>(6,638)</u>	<u>(614)</u>	<u>8,447</u>
Cash flows from investing activities:			
Acquisitions	(4,413)	(800)	-
Purchases of property, plant and equipment	(5,499)	(2,042)	(17,615)
Additions to intangible rights and software development	(633)	(551)	(281)
Proceeds from sale of property, plant and equipment	13	11	6
Investment in unconsolidated affiliate	-	-	(710)
Discontinued operations investing activities	(308)	(397)	(417)
Net cash used in investing activities	<u>(10,840)</u>	<u>(3,779)</u>	<u>(19,017)</u>
Cash flows from financing activities:			
Borrowings (payments) on revolving line of credit	5,000	-	-
Proceeds from sale leaseback transactions	-	605	5,912
Payments on capital lease obligations	(756)	(716)	(2)
Proceeds from term loan	-	-	2,584
Principal payments on term loan	-	-	(2,584)
Proceeds from stock option and warrant exercises, net of shares tendered	1,267	357	266
Net cash provided by financing activities	<u>5,511</u>	<u>246</u>	<u>6,176</u>
NET DECREASE IN CASH AND CASH EQUIVALENTS	(11,967)	(4,147)	(4,394)
CASH AND CASH EQUIVALENTS AT BEGINNING OF YEAR	<u>20,169</u>	<u>24,316</u>	<u>28,710</u>
CASH AND CASH EQUIVALENTS AT END OF YEAR	<u>\$ 8,202</u>	<u>\$ 20,169</u>	<u>\$ 24,316</u>

See accompanying notes to consolidated financial statements.

POWERSECURE INTERNATIONAL, INC. AND SUBSIDIARIES

NOTES TO CONSOLIDATED FINANCIAL STATEMENTS FOR THE YEARS ENDED DECEMBER 31, 2010, 2009 AND 2008 (in thousands, except per share data)

1. Description of Business and Basis of Presentation

Description of Business

PowerSecure International, Inc., headquartered in Wake Forest, North Carolina, is a leading provider of Energy and Smart Grid Solutions to electric utilities, their commercial, institutional and industrial customers, and of Energy Services to oil and natural gas producers.

Our core business is our Energy and Smart Grid Solutions segment, operated through our largest wholly-owned subsidiary PowerSecure, Inc., which we refer to as "our PowerSecure subsidiary". This segment includes our three core strategic business areas: Interactive Distributed Generation[®], Utility Infrastructure and Energy Efficiency. These three areas are focused on providing utilities and their commercial, institutional and industrial customers with products and services to help them generate, deliver, and utilize electricity more efficiently and are intended to deliver strong returns on investment. They share common or complementary utility relationships and customer types, common sales and overhead resources, and facilities. However, each business area in this segment possesses distinct technical disciplines and specific capabilities that are designed to provide a competitive advantage in the marketplace for its specific products and services, including personnel, technology, engineering, and intellectual capital. This segment operates primarily out of our Wake Forest, North Carolina headquarters office, and its operations also include several satellite offices and manufacturing facilities, the largest of which are in Raleigh, North Carolina, Randleman, North Carolina, McDonough, Georgia, and Anderson, South Carolina. The locations of our sales organization for this segment are generally in close proximity to the utilities and commercial, industrial, and institutional customers they serve.

Until recently, our Energy Services segment operated through our two other principal operating subsidiaries, Southern Flow Companies, Inc., which we refer to as "Southern Flow", and WaterSecure Holdings, Inc., which we refer to as "WaterSecure". WaterSecure holds an investment of 40% of the equity interests in an unconsolidated business, Marcum Midstream 1995-2 Business Trust, which we refer to as "MM 1995-2" or as our "WaterSecure operations". Our WaterSecure operations provide water processing, recycling, and disposal services for oil and natural gas producers in northeastern Colorado utilizing environmentally responsible technologies and processes. Our Southern Flow business, which was sold in 2011 pursuant to a purchase agreement executed in December 2010, provides oil and natural gas measurement services to customers involved in oil and natural gas production, transportation, and processing, with a focus on the natural gas market. Due to its sale, Southern Flow's operations are now reflected as discontinued operations in the accompanying consolidated financial statements. See Note 5 for more information regarding the sale of Southern Flow.

See Note 14 for more information concerning our reportable segments.

Basis of Presentation

Organization – The accompanying consolidated financial statements include the accounts of PowerSecure International, Inc. and its subsidiaries, primarily, PowerSecure, Inc. (“our PowerSecure subsidiary”) (and its majority-owned and wholly-owned subsidiaries, UtilityEngineering, Inc., PowerServices, Inc., EnergyLite, Inc., EfficientLights, LLC, Innovative Electronic Solutions Lighting, LLC (“IES”), Reid’s Trailer, Inc. and PowerPackages, LLC), Southern Flow Companies, Inc. (“Southern Flow”), WaterSecure Holdings, Inc. (“WaterSecure”), and Marcum Gas Metering, Inc. (fka Metretek International, Inc. and Metretek, Incorporated) (“Metretek Florida”), collectively referred to as the “Company” or “we” or “us” or “our”.

The consolidated financial statements have been prepared in conformity with accounting principles generally accepted in the United States of America. The consolidated financial statements presented reflect entries necessary for the fair presentation of the Consolidated Statements of Operations for the years ended December 31, 2010, 2009 and 2008, Consolidated Balance Sheets as of December 31, 2010 and 2009 and Consolidated Statements of Cash Flows for the years ended December 31, 2010, 2009 and 2008. All entries required for the fair presentation of the financial statements are of a normal recurring nature.

Principles of Consolidation – The consolidated financial statements include the accounts of PowerSecure International, Inc. and its subsidiaries after elimination of intercompany accounts and transactions. We use the equity method to account for our investment in unconsolidated affiliate.

Noncontrolling Interests – The noncontrolling ownership interests in the income or losses of our majority-owned subsidiaries is included in our consolidated statements of operations as a reduction or addition to net income to derive income attributable to PowerSecure International stockholders. Similarly, the noncontrolling ownership interest in the undistributed equity of our majority-owned subsidiaries is shown as a separate component of stockholders’ equity in our consolidated balance sheet.

Until April 30, 2010, our PowerSecure subsidiary held a 67% controlling ownership interest in EfficientLights which is consolidated in our financial statements. On April 30, 2010, we acquired the remaining 33% noncontrolling ownership interest in EfficientLights, at which time EfficientLights became a wholly-owned subsidiary of our PowerSecure subsidiary. Also, on April 1, 2010, our PowerSecure subsidiary acquired a 67% controlling ownership interest in IES (see Note 4). Accordingly, our noncontrolling interest consists of results of EfficientLights through April 30, 2010 and the results of IES commencing April 1, 2010. As a result, period-to-period comparisons of the aggregate amount of noncontrolling interests are not necessarily comparable.

The following is a reconciliation of the amounts attributable to the noncontrolling interest for the years ended December 31, 2010, 2009 and 2008:

	Noncontrolling Interest		
	EfficientLights	IES	Total
Balance, January 1, 2008	\$ -	\$ -	\$ -
Income (loss)	-	-	-
Distributions	-	-	-
Balance, December 31, 2008	-	-	-
Income (loss)	1,512	-	1,512
Distributions	(405)	-	(405)
Balance, December 31, 2009	1,107	-	1,107
Capital Contributions	-	2,188	2,188
Income (loss)	280	(433)	(153)
Distributions	(877)	-	(877)
Acquisition of noncontrolling interest	(510)	-	(510)
Balance, December 31, 2010	\$ -	\$ 1,755	\$ 1,755

Use of Estimates – The preparation of our consolidated financial statements in conformity with accounting principles generally accepted in the United States of America requires that our management make estimates and assumptions that affect the reported amounts of assets and liabilities and disclosure of contingent assets and liabilities at the date of the financial statements and the reported amounts of revenues and expenses during the reporting period. Actual results could differ from those estimates. Significant estimates include percentage-of-completion estimates for revenue and cost of sales recognition, incentive compensation and commissions, allowance for doubtful accounts receivable, inventory valuation reserves, warranty reserves and our deferred tax valuation allowance.

Reclassifications – During the fourth quarter of 2010, our board of directors approved a plan to sell our Southern Flow business (see Note 5). The operations of Southern Flow have been reclassified to discontinued operations for all periods presented in the accompanying consolidated financial statements. In addition, certain 2009 and 2008 amounts have been reclassified to conform to current year presentation. Such reclassifications had no effect on net income or stockholders' equity.

2. Summary of Significant Accounting Policies and Recent Accounting Standards

Revenue Recognition – For our distributed generation turn-key project-based sales and our utility infrastructure projects, we recognize revenue and profit as work progresses using the percentage-of-completion method, which relies on various estimates. We believe the use of the percentage-of-completion method of accounting for our distributed generation and utility infrastructure projects is preferable to the completed contract method because our typical projects occurs over several accounting periods and the percentage-of-completion method is a better method to match the revenues and costs to the reporting period in which the construction services are performed. Nearly all of our distributed generation and utility infrastructure projects are fixed-price contracts.

In applying the percentage-of-completion method to our distributed generation turn-key projects, we have identified the key output project phases that are standard components of these projects. We have further identified, based on past experience, an estimate of the value of each of these

output phases based on a combination of costs incurred and the value added to the overall construction project. While the order of these phases varies depending on the project, each of these output phases is necessary to complete each project and each phase is an integral part of the turnkey product solution we deliver to our customers. We use these output phases and percentages to measure our progress toward completion of our construction projects. For each reporting period, the status of each project, by phase, is determined by employees who are managers of or are otherwise directly involved with the construction project and is reviewed by our accounting personnel. Utilizing this information, we recognize project revenues (and associated project costs) and gross profit based on the percentage associated with output phases that are complete or in process on each of our projects.

In applying the percentage-of-completion method to our utility infrastructure projects, revenues and gross profit are recognized as work is performed based on the relationship between actual costs incurred and total estimated costs at completion.

In all cases where we utilize the percentage-of-completion, revenues and gross profit are adjusted prospectively for revisions in estimated total contract costs and contract values. Estimated losses, if any, are recorded when identified. While a project is in process, amounts billed to customers in excess of revenues recognized to date are classified as current liabilities. Likewise, amounts recognized as revenue in excess of actual billings to date are recorded as unbilled accounts receivable. In the event adjustments are made to the contract price, including, for example, adjustments for additional wire or other raw materials, we recognize the associated revenue when the actual costs are incurred and the customer is billed.

Because the percentage-of-completion method of accounting relies upon estimates described above, recognized revenues and profits are subject to revision as a project progresses to completion. Revisions in profit estimates are charged to income in the period in which the facts that give rise to the revision become known. In the event we were required to adjust any particular project's estimated revenues or costs, the effect on the current period earnings may or may not be significant. If, however, conditions arise that requires us to adjust our estimated revenues or costs for a series of similar construction projects, the effect on current period earnings would more likely be significant. In addition, certain contracts provide for cancellation provisions prior to completion of a project. The cancellation provisions generally provide for payment of costs incurred, but may result in an adjustment to profit already recognized in a prior period.

We recognize equipment and product revenue when persuasive evidence of a non-cancelable arrangement exists, delivery has occurred and/or services have been rendered, the price is fixed or determinable, and collectability is reasonably assured. Equipment and product sales are generally made directly to end users of the product, who are responsible for payment for the product.

Service revenue includes regulatory consulting and rate design services, power system engineering services, energy conservation services, and monitoring and maintenance services. Revenues from these services are recognized when the service is performed and the customer has accepted the work.

Additionally, our utility infrastructure business provides services to utilities involving construction, maintenance, and upgrades to their electrical transmission and distribution systems which is not fixed price project-based work. These services are delivered by us under contracts

which are generally of two types. In the first type, we are paid a fixed fee based on the number of units of work we complete, an example of which is number of new utility poles we replace. In the second type, we are paid for the time and materials utilized to complete the work, plus a profit margin. In both cases, we recognize revenue as these services are delivered.

Revenues for our recurring revenue distributed generation projects are recognized over the term of the contract or when energy savings are realized by the customer at its site. Under these arrangements, we provide utilities and their customers with access to PowerSecure-owned and operated distributed generation systems for standby power and to deliver peak shaving benefits. These contracts can involve multiple parties, with one party paying us for the value of backup power (usually, but not always, a commercial, industrial, or institutional customer), and one party paying us for the value of the electrical capacity provided by the system (either the customer or a utility).

Sales of certain goods or services sometimes involve the provision of multiple elements. Revenues from contracts with multiple element arrangements are recognized as each element is earned based on the relative fair value of each element, provided the delivered elements have value to customers on a standalone basis. Amounts allocated to each element are based on its objectively determined fair value, such as the sales price for the product or service when it is sold separately or competitor prices for similar products or services.

Cash and Cash Equivalents – Cash and all highly liquid investments with a maturity of three months or less from the date of purchase, including money market mutual funds, short-term time deposits, and government agency and corporate obligations, are classified as cash and cash equivalents. Supplemental statement of cash flows information is as follows:

	<u>2010</u>	<u>2009</u>	<u>2008</u>
Cash paid during the year for:			
Interest-continuing operations	\$ 461	\$ 474	\$ 171
Income taxes-continuing operations	281	169	432
Income taxes-discontinued operations	62	169	59
Supplemental schedule of non-cash investing and financing activities:			
Capital lease obligations incurred for the purchase of equipment	-	-	5,912
Equipment transferred to inventory	-	-	288

Accounts Receivable – Our customers include a wide variety of mid-sized and large businesses, utilities and institutions. We perform ongoing credit evaluations of our customers' financial condition and generally do not require collateral. We continuously monitor collections and payments from our customers and regularly adjust credit limits of customers based upon payment history and a customer's current credit worthiness, as judged by us. We maintain a provision for estimated credit losses.

Concentration of Credit Risk – We are subject to concentrations of credit risk from our cash and cash equivalents and accounts receivable. From time to time, we have derived a material portion of our revenues from one or more significant customers. We limit our exposure to credit risk associated with cash and cash equivalents by placing our cash and cash equivalents with multiple

domestic financial institutions. Nevertheless, our cash in bank deposit accounts at these financial institutions frequently exceeds federally insured limits. We further limit our exposure to credit risk associated with these cash accounts by adherence to our investment policy. We have not experienced any losses in such accounts.

To date, nearly all our revenues have been derived from sales to customers within the United States.

Inventories – Inventories are stated at the lower of cost (determined primarily on a specific-identification basis) or market. Inventories at December 31, 2010 and 2009 are summarized as follows:

	<u>2010</u>	<u>2009</u>
Raw materials, equipment and supplies	\$ 16,088	\$ 14,321
Work in process	7,161	5,959
Finished goods and merchandise	3,554	3,129
Valuation reserve	<u>(1,792)</u>	<u>(1,777)</u>
Total	<u>\$ 25,011</u>	<u>\$ 21,632</u>

Raw materials, equipment and supplies consist primarily of equipment with long lead-times purchased for anticipated customer orders. Work in progress consists primarily of equipment and parts allocated to specific distributed generation turn-key projects and utility infrastructure projects accounted for on the percentage-of-completion basis. Finished goods and merchandise consists primarily of LED-based lighting products stocked to meet customer order and delivery requirements.

Property, Plant and Equipment – Property, plant and equipment are stated at cost and are generally depreciated using the straight-line method over their estimated useful lives, which depending on asset class ranges from 3 to 30 years. Depreciation expense on property, plant and equipment was \$2,091, \$1,598, and \$1,161 for the years ended December 31, 2010, 2009 and 2008, respectively. Property, plant and equipment includes items under capital lease with a net book value of \$5,419 and \$5,719 at December 31, 2010 and 2009, respectively.

Goodwill and Other Intangible Assets – We amortize the cost of intangible assets that do not have an indefinite life over their estimated useful lives. We do not amortize goodwill and intangible assets with indefinite lives. Amortization expense on intangible assets was \$590, \$471, and \$619 for the years ended December 31, 2010, 2009 and 2008, respectively. We perform reviews of goodwill and intangible assets with indefinite lives for impairment annually, as of October 1, or more frequently if impairment indicators arise. Based on the results of our annual reviews, we have concluded that there has been no impairment of goodwill or intangible assets during the three years ended December 31, 2010. The following is a summary of changes in the balance of our goodwill for the year ended December 31, 2010:

	<u>2010</u>
Goodwill, beginning of year	\$ 7,256
Addition due to the aquisition of IES (Note 4)	5,945
Goodwill included in assets of discontinued operations held for sale (Note 5)	<u>(5,231)</u>
Goodwill, end of year	<u>\$ 7,970</u>

We capitalize software development costs integral to our products once technological feasibility of the products and software has been determined. Purchased software and software development costs are amortized over five years, using the straight-line method. Unamortized software and software development costs at December 31, 2010 and 2009 are \$543 and \$407, respectively. Patents and license agreements are amortized using the straight-line method over the lesser of their estimated economic lives or their legal term of existence, currently 3 to 5 years. Unamortized patent and license costs at December 31, 2010 and 2009 are \$974 and \$463, respectively.

During 2006, our PowerSecure subsidiary purchased contract and intellectual property rights to provide services to federal customers of an investor-owned utility. The contract rights are being amortized over their expected contract terms. The intellectual property rights are being amortized over ten years, using the straight-line method. Unamortized contract and intellectual property rights at December 31, 2010 and 2009 are \$425 and \$500, respectively.

Debt Issuance Costs – Debt issuance costs are amortized over the term of the corresponding debt instrument using the straight-line method, which approximates the effective interest method. Amortization and write-off of debt issuance costs was \$141, \$148 and \$103 for the years ended December 31, 2010, 2009 and 2008, respectively, and is included in interest expense in our consolidated statement of operations.

Debt issuance costs are included in other current and non-current assets, and consisted of the following as of December 31, 2010 and 2009:

	<u>2010</u>	<u>2009</u>
Debt issuance costs, beginning of year	\$ 299	\$ 433
Addition of debt issuance costs	156	14
Amortization of debt issuance costs	<u>(141)</u>	<u>(148)</u>
Debt issuance costs, end of year	<u>\$ 314</u>	<u>\$ 299</u>

Accrued and Other Liabilities – Accrued and other liabilities at December 31, 2010 and 2009 are summarized as follows:

	<u>2010</u>	<u>2009</u>
Accrued project costs	\$ 3,746	\$ 8,844
Payroll, employee benefits and related liabilities	3,024	4,441
Sales, property and franchise taxes payable	187	361
Advance billings on projects in progress	1,842	4,913
Preferred stock redemption obligation	104	104
Deferred revenue	545	512
Warranty reserve	1,087	769
Other	<u>451</u>	<u>435</u>
Total	<u>\$ 10,986</u>	<u>\$ 20,379</u>

Warranty Reserve – We provide a standard warranty for our distributed generation equipment, switchgear equipment, utility infrastructure equipment, and our Energy Efficiency unit's lighting products, which range generally between one and five years. In addition, we offer extended warranty terms on our distributed generation turn-key and switchgear projects. We reserve for the estimated cost of product warranties when revenue is recognized, and we evaluate our reserve periodically by comparing our warranty repair experience by product. The purchase price for extended warranties or extended warranties included in the contract terms are deferred as a component of our warranty reserve. The warranty reserve included in accrued and other liabilities is set forth below.

	<u>Year Ended December 31,</u>		
	<u>2010</u>	<u>2009</u>	<u>2008</u>
Warranty provision at the beginning of the year	\$ 769	\$ 697	\$ 421
Accruals for warranties issued during the year	380	109	326
Warranty settlements during the year	(62)	(37)	(30)
Changes in liability for pre-existing warranties during the year	<u>-</u>	<u>-</u>	<u>(20)</u>
Warranty provision at the end of the year	<u>\$ 1,087</u>	<u>\$ 769</u>	<u>\$ 697</u>

Share-Based Compensation – We measure compensation cost for all stock-based awards at the fair value on date of grant and recognize the compensation expense over the service period for awards expected to vest, net of estimated forfeitures. We measure the fair value of restricted stock awards based on the number of shares granted and the quoted price of our common stock on the date of the grant, and we measure the fair value of stock options using the Black-Scholes valuation model.

Pre-tax share-based compensation expense for our stock options and restricted stock awards recognized during the years ended December 31, 2010, 2009 and 2008 was \$1,942, \$2,123 and \$2,384, respectively, and is included in general and administrative expense in the accompanying consolidated statements of operations.

Impairment or Disposal of Long-Lived Assets – We evaluate our long-lived assets whenever significant events or changes in circumstances occur that indicate that the carrying amount of an asset may be impaired. Recoverability of these assets is determined by comparing the forecasted

undiscounted future net cash flows from the operations to which the assets relate, based on management's best estimates using appropriate assumptions and projections at the time, to the carrying amount of the assets. If the carrying value is determined not to be recoverable from future operating cash flows, the asset is deemed impaired and an impairment loss is recognized equal to the amount by which the carrying amount exceeds the estimated fair value of the asset or assets. We did not record any impairment charges during the three years ended December 31, 2010.

Income Taxes – We recognize deferred income tax assets and liabilities for the estimated future tax consequences attributable to temporary differences between the financial statement carrying amounts of existing assets and liabilities and their respective tax basis. We have net operating loss carryforwards available in certain jurisdictions to reduce future taxable income. Future tax benefits for net operating loss carryforwards are recognized to the extent that realization of these benefits is considered more likely than not. To the extent that available evidence raises doubt about the realization of a deferred income tax asset, a valuation allowance is established.

We recognize a liability and income tax expense, including potential penalties and interest, for uncertain income tax positions taken or expected to be taken. The liability is adjusted for positions taken when the applicable statute of limitations expires or when the uncertainty of a particular position is resolved.

Subsequent Events – Subsequent events are events or transactions that occur after the balance sheet date but before the financial statements are issued or are available to be issued and are classified as either “recognized subsequent events” or “non-recognized subsequent events.” We recognize and include in our financial statements the effects of subsequent events that provide additional evidence about conditions that existed at the balance sheet date. We disclose non-recognized subsequent events that provide evidence about conditions that arise after the balance sheet date but are not yet reflected in our financial statements when such disclosure is required to prevent the financial statements from being misleading.

Recent Accounting Standards

Revenue Recognition—Milestone Method – In April 2010, the FASB issued Accounting Standards Update (“ASU”) No. 2010-17 – *Revenue Recognition - Milestone Method (Topic 605): Milestone Method of Revenue Recognition*. This standard provides guidance on defining a milestone and determining when it may be appropriate to apply the milestone method of revenue recognition for certain research and development transactions. Under this new standard, a company can recognize as revenue consideration that is contingent upon achievement of a milestone in the period in which it is achieved, only if the milestone meets all criteria to be considered substantive. This standard will be effective for us on a prospective basis beginning January 1, 2011. We have evaluated the potential impact of this standard and expect it will have no significant impact on our financial position or results of operations.

Improving Disclosures about Fair Value Measurements – In January 2010, the FASB issued ASU No. 2010-06 – *Fair Value Measurements and Disclosures (Topic 820): Improving Disclosures about Fair Value Measurements*. This standard amends the disclosure guidance with respect to fair value measurements for both interim and annual reporting periods. Specifically, this standard requires new disclosures for significant transfers of assets or liabilities between Level 1 and Level 2 in the fair value hierarchy; separate disclosures for purchases, sales, issuance and settlements of Level 3 fair value items on a gross, rather than net basis; and more robust

disclosure of the valuation techniques and inputs used to measure Level 2 and Level 3 assets and liabilities. Except for the detailed disclosures of changes in Level 3 items, which will be effective for us as of January 1, 2011, the remaining new disclosure requirements were effective for us as of January 1, 2010. The adoption of the new guidance on January 1, 2010 had no effect on our financial position or results of operations or on our financial statement disclosures.

Multiple Deliverable Revenue Arrangements – In October 2009, the FASB issued ASU No. 2009-13 - *Multiple Deliverable Revenue Arrangements – A Consensus of the FASB Emerging Issues Task Force: (Topic 605) Revenue Recognition*. ASU No. 2009-13 provides application guidance on whether multiple deliverables exist, how the deliverables should be separated and how the consideration should be allocated to one or more units of accounting. This update establishes a selling price hierarchy for determining the selling price of a deliverable. The selling price used for each deliverable will be based on vendor-specific objective evidence, if available, third-party evidence if vendor-specific objective evidence is not available, or estimated selling price if neither vendor-specific or third-party evidence is available. We will be required to apply the new guidance prospectively for revenue arrangements entered into or materially modified after January 1, 2011. We have evaluated the potential impact of this standard and expect it will have no significant impact on our financial position or results of operations.

3. Earnings per Share

Basic earnings per share is computed by dividing net income attributable to PowerSecure International, Inc. common stockholders by the weighted average number of common shares outstanding during the period. Diluted earnings per share attributable to PowerSecure International, Inc. common stockholders is computed using the weighted average number of common shares outstanding and, when dilutive, potential common shares from stock options and warrants using the treasury stock method. Diluted earnings per share excludes the impact of potential common shares related to stock options and warrants in periods in which we report a loss from continuing operations or in which the option or warrant exercise price is greater than the average market price of our common stock during the period because the effect would be antidilutive.

The following table sets forth the calculation of basic and diluted earnings (loss) per share attributable to PowerSecure International, Inc. common stockholders:

	Year Ended December 31,		
	2010	2009	2008
Income from continuing operations	\$ 919	\$ 1,280	\$ 7,637
Income from discontinued operations	<u>2,543</u>	<u>1,513</u>	<u>3,021</u>
Net income	<u>\$ 3,462</u>	<u>\$ 2,793</u>	<u>\$ 10,658</u>
Basic weighted-average common shares outstanding in period	18,133	17,177	16,978
Add dilutive effects of stock options and warrants	<u>470</u>	<u>166</u>	<u>306</u>
Diluted weighted-average common shares outstanding in period	<u>18,603</u>	<u>17,343</u>	<u>17,284</u>
Basic earnings per common share:			
Income from continuing operations	\$ 0.05	\$ 0.07	\$ 0.45
Income from discontinued operations	<u>0.14</u>	<u>0.09</u>	<u>0.18</u>
Basic earnings per common share	<u>\$ 0.19</u>	<u>\$ 0.16</u>	<u>\$ 0.63</u>
Diluted earnings per common share:			
Income from continuing operations	\$ 0.05	\$ 0.07	\$ 0.44
Income from discontinued operations	<u>0.14</u>	<u>0.09</u>	<u>0.18</u>
Diluted earnings per common share	<u>\$ 0.19</u>	<u>\$ 0.16</u>	<u>\$ 0.62</u>

4. Acquisitions

Acquisition of IES – On April 1, 2010, we launched an expansion of our LED lighting business through the formation and acquisition of a 67% controlling interest in IES, which acquired substantially all of the assets and business of a leading LED lighting development company, Innovative Electronic Solutions, LLC, in order to accelerate the expansion of new LED lighting products and to capitalize on the growing marketplace for LED lighting. The new business has and will continue to design and manufacture new LED-based lighting products ("light emitting diode" based products) for commercial, industrial, and retail customers. The business will include turn-key product development, design and manufacturing of solid state LED-based lights and their components, including power drivers, light engines, and thermal management solutions.

IES commenced its business and operations by acquiring, on April 1, 2010, substantially all of the assets and business of Innovative Electronic Solutions, LLC, a North Carolina limited liability company. Since 2002, the business acquired by IES has engineered innovative lighting products for many of the largest and fastest growing LED lighting companies in the marketplace. Among these products is a leading LED street light for utilities. In addition, IES has acquired expertise and market leading technology in the areas of LED power drivers, light engines, and thermal management solutions. This expertise and technology is expected to enable IES to design and manufacture high quality LED lighting products with strong competitive advantages driven by lighting designs that maximize the energy efficiency savings for given light outputs. IES' manufacturing operations are located in the Raleigh, North Carolina area.

Our PowerSecure subsidiary owns 67% of the membership interests in, and controls the management of, IES. Our PowerSecure subsidiary contributed approximately \$4.4 million to IES to fund the capitalization of IES and the acquisition by IES of substantially all of the assets and business of the seller as well as the assumption by IES of the seller's current liabilities. In connection with its sale and contribution of substantially all of its asset and business to IES, the seller received the remaining 33% membership interests in IES. The purchase price was allocated to assets and liabilities acquired as follows:

Accounts receivable	\$ 349
Inventory	282
Equipment	427
Deposits	14
Intangible rights	596
Goodwill	5,945
Accounts payable	(977)
Accrued and other liabilities	(35)
Non-controlling interest	(2,188)
Net assets acquired	<u>\$ 4,413</u>

The operations of IES are included within our Energy and Smart Grid Solutions operating segment commencing from the date of acquisition. Pro forma results of operations for the years ended December 31, 2009 and 2008 have not been included herein as the effects of the acquisition were not material to our results of operations.

Both our PowerSecure subsidiary and the seller are subject to various buy-sell rights and obligations with respect to their equity interests in IES, including various call, put and drag-along rights and obligations. Commencing in 2012, our PowerSecure subsidiary has the right to purchase the minority interest in IES held by the seller and thus increase its ownership of IES to 100%, through the issuance and delivery of shares of our common stock in an amount based on a formula derived from the value of our stock using our E.P.S multiple (or if we do not have positive net income, then our revenue multiple) applied to IES's minority interest, subject to a minimum value of \$10 million.

Acquisition of Noncontrolling Interest in EfficientLights – On April 30, 2010, our PowerSecure subsidiary, which previously owned two-thirds of the equity interests in EfficientLights, exercised its option and acquired the remaining one-third minority interest in EfficientLights in exchange for 1,025,641 shares of our common stock. The minority interest in EfficientLights was previously owned by the founder, who is also the President of EfficientLights, and five other key employees of EfficientLights. EfficientLights markets and sells LED-based lights that enhance the quality of light while reducing energy and maintenance costs for refrigerated cases and storage coolers in grocery, drug, and convenience stores, and is in the process of developing other LED-based lighting products, including additional in-store retail lighting, LED-based parking lot lights, street lights and security lights. As a result of the exercise of our option to purchase the remaining one-third minority interest, EfficientLights has become a wholly-owned subsidiary of our PowerSecure subsidiary and there is no reduction in our net income for net income attributable to the noncontrolling interest in EfficientLights after April 30, 2010.

PowerPackages Acquisition – In May 2009, our PowerSecure subsidiary established a new business unit, PowerPackages, LLC, to provide our utility partners with an efficient, dependable continuous power source for their customers. The business unit was purchased to broaden our PowerSecure subsidiary’s interactive distributed generation system capabilities by incorporating medium speed engine technology as the system’s power source. To facilitate the new business unit, our PowerSecure subsidiary purchased, for cash, certain inventory and equipment of Design Power International, Inc. The fair value of the assets acquired was \$800, which also represented the purchase price of the assets. The following provides additional information regarding the fair value of the assets acquired:

Inventory	\$	408
Equipment		392
Total assets		<u>\$ 800</u>

The operations of PowerPackages, LLC have been included within our Energy and Smart Grid Solutions operating segment from the date of acquisition. Pro forma results of operations for the year ended December 31, 2008 have not been included herein as the effects of the acquisition were not material to our results of operations.

5. Discontinued Operations

On December 30, 2010, we entered into a purchase and sale agreement for the sale of Southern Flow which was part of our Energy Services segment. The sale closed on January 14, 2011, with an effective date of January 1, 2011. Pursuant to the terms of the purchase and sale agreement, Zedi, Inc., a Canadian corporation, through its wholly-owned subsidiary, purchased 100% of the stock of Southern Flow. Upon closing in January 2011, we received cash proceeds of \$16,515, consisting of a base purchase price of \$15,550, and \$965 for additional Southern Flow working capital conveyed in the transaction. The sale of Southern Flow will be reflected in our 2011 consolidated statement of operations as a gain on disposal of discontinued operations.

In December 2007, our board of directors approved a plan to sell substantially all of the assets of Metrotek Florida, which operated our automated data collection and telemetry segment. On March 14, 2008, Metrotek Florida entered into an Asset Purchase Agreement with Mercury Instruments LLC (“Mercury”). Under the purchase agreement, Metrotek Florida sold substantially all of its assets and business to Mercury for a total purchase price of \$2,250. The sale closed on March 31, 2008. Upon closing of the sale, we recorded an additional loss on disposition in the amount of \$42 during the year ended December 31, 2008 to reflect changes in assets and liabilities sold from December 31, 2007 to the date of closing.

The sale of both Southern Flow and Metrotek Florida were made pursuant to our review of our strategic alternatives for our non-core businesses. The operations of Southern Flow and Metrotek Florida have been included in our consolidated statements of operations as discontinued operations for all periods presented. Results of discontinued operations for the years ended December 31, were as follows:

	<u>2010</u>	<u>2009</u>	<u>2008</u>
Total revenues	\$ 19,380	\$ 17,113	\$ 20,732
Operating expenses	<u>16,771</u>	<u>14,978</u>	<u>17,577</u>
Income before income taxes	2,609	2,135	3,155
Income tax provision	<u>(66)</u>	<u>(622)</u>	<u>(92)</u>
Income from operations	2,543	1,513	3,063
Gain (loss) on disposal	-	-	(42)
Income tax benefit on disposal	<u>-</u>	<u>-</u>	<u>-</u>
Income from discontinued operations	<u>\$ 2,543</u>	<u>\$ 1,513</u>	<u>\$ 3,021</u>

The following assets and liabilities have been segregated and included in Assets of discontinued operations held for sale and Liabilities of discontinued operations held for sale, as appropriate, in the consolidated balance sheet as of December 31, 2010, and represent the assets and liabilities of Southern Flow that were sold in January 2011:

	<u>December 31,</u> <u>2010</u>
Cash and cash equivalents	\$ 250
Trade receivables, net of allowance for doubtful accounts	3,427
Inventories	2,182
Prepaid expenses and other current assets	169
Property, Plant and equipment, net	922
Goodwill	5,231
Other assets	2
Assets of discontinued operations held for sale	<u>\$ 12,183</u>
Accounts payable	519
Accrued and other liabilities	871
Current income taxes payable	19
Capital lease obligations	2
Liabilities of discontinued operations held for sale	<u>\$ 1,411</u>

6. Investment in Unconsolidated Affiliate

Through WaterSecure, we currently own 40.45% of the equity interests in Marcum Midstream 1995-2 Business Trust ("MM 95-2"). MM 95-2 owns and operates several water processing, recycling, and disposal facilities serving oil and natural gas producers in northeastern Colorado. The balance of our equity investment MM 95-2 includes approximately \$648 and \$748 of unamortized purchase premiums we paid on our acquired interests at December 31, 2010 and 2009, respectively. The premiums are being amortized over a period of 14 years, which represents the estimated weighted average useful life of the underlying assets acquired. Amortization expense on the premiums was \$73, \$74, and \$67 for the years ended December 31, 2010, 2009, and 2008, respectively. The following table sets forth summarized financial information for MM 95-2 at December 31, 2010 and 2009 and for the years ended December 31, 2010, 2009 and 2008:

	December 31,	
	2010	2009
Total current assets	\$ 3,753	\$ 2,942
Property, plant and equipment, net	11,616	8,879
Total other assets	<u>4</u>	<u>6</u>
Total assets	<u>\$ 15,373</u>	<u>\$ 11,827</u>
Total current liabilities	\$ 2,462	\$ 1,433
Long-term note payable	4,100	2,749
Total shareholders' equity	<u>8,811</u>	<u>7,645</u>
Total liabilities and shareholders' equity	<u>\$ 15,373</u>	<u>\$ 11,827</u>

	Year Ended December 31,		
	2010	2009	2008
Total revenues	\$ 18,331	\$ 12,969	\$ 17,906
Total costs and expenses	<u>10,464</u>	<u>7,610</u>	<u>8,652</u>
Net income	<u>\$ 7,867</u>	<u>\$ 5,359</u>	<u>\$ 9,254</u>

7. Deferred Compensation Plan

In his employment agreement (see Note 10), Sidney Hinton, our President and Chief Executive Officer, has a deferred compensation arrangement that provides for payments by us to him, upon retirement, in monthly amounts ranging from \$15 per month, if he commences receiving payments at age 53, to \$20 per month, if he commences receiving payments at age 58, and thereafter such payments will continue for Mr. Hinton's life. The deferred compensation payments under the plan vest on the earlier of August 15, 2012 or upon a change in control. We funded our obligation under the deferred compensation plan in 2007 through the purchase of a fixed deferred annuity contract through John Hancock Annuities. The deferred annuity contract provides for a guaranteed minimum interest rate on the annuity sufficient to meet our obligations under the deferred compensation plan. If the deferred compensation fails to vest, then the annuity reverts to us. We are subject to income tax on the earnings of the annuity. For fair value measurement purposes, we classify the annuity as a Level 3 investment, which refers to securities not traded in an active market and for which no significant observable market inputs are available. The fair value of the annuity at December 31, 2010 and 2009 is \$2,306 and \$2,220, respectively, and is included in the in the accompanying consolidated balance sheet under other assets. The increases in the fair value of the annuity for the years ended December 31, 2010 was \$86, \$87, and \$132, respectively, and consists primarily of the guaranteed minimum interest earned on the annuity for the year. We are accruing our obligation under the deferred compensation agreement over a period of eight years. The liability for the deferred compensation obligation at December 31, 2010 and 2009 is \$1,053 and \$721, respectively, and is included in the accompanying consolidated balance sheet under deferred compensation obligation. The accompanying consolidated statements of operations includes general and administrative expense in the amount of \$332, \$333 and \$329 for the years ended December 31, 2010, 2009 and 2008, respectively, associated with the deferred compensation plan.

8. Debt

Line of Credit – We have had a credit facility with Citibank, N.A. (“Citibank”), as administrative agent and lender, and other lenders since entering into a credit agreement in August 2007. At December 31, 2010, our credit agreement with Citibank along with SunTrust Bank and Branch Banking and Trust Company (“BB&T”) as additional lenders, provided for a \$50.0 million senior, first-priority secured revolving and term credit facility. In January 2011, the credit facility was amended to facilitate the sale of Southern Flow (see Note 5), modify certain financial covenants to accommodate our financial profile after that sale and reflect a change in lenders. The credit facility, as amended, is now a \$25.0 million senior, first-priority secured revolving credit facility with Citibank and BB&T as lenders. The credit facility is guaranteed by all of our active subsidiaries and secured by all of our assets and the assets of our active subsidiaries.

As amended, the credit facility, as a revolving credit facility, matures and terminates on November 12, 2013. However, we have the option prior to that maturity date to convert a portion of outstanding principal balance into a non-revolving term loan for a two year period expiring November 12, 2015, making quarterly payments based upon a four year fully amortized basis, with the remaining outstandings due as a balloon payment on November 12, 2015.

We intend to continue to use the proceeds available under the credit facility to finance our PowerSecure subsidiary’s recurring revenue projects as well as to finance capital expenditures, working capital, acquisitions, and general corporate purposes. Under the terms of the amended credit facility, we are required, at all times until April 1, 2012, to maintain cash balances of at least 65% of our outstanding borrowings under the revolving credit facility.

Outstanding balances under the credit facility bear interest, at our discretion, at either the London Interbank Offered Rate for the corresponding deposits of U. S. Dollars plus an applicable margin, which is on a sliding scale ranging from 200 basis points to 325 basis points based upon the our leverage ratio, or at Citibank’s alternate base rate plus an applicable margin, on a sliding scale ranging from 25 basis points to 150 basis points based upon our leverage ratio. Our leverage ratio is the ratio of our funded indebtedness as of a given date to our consolidated EBITDA as defined in the credit agreement for the four consecutive quarters ending on such date. Citibank’s alternate base rate is equal to the higher of the Federal Funds Rate as published by the Federal Reserve of New York plus 0.50%, and Citibank’s prime commercial lending rate.

The credit facility is not subject to any borrowing base computations, but does contain certain financial covenants. Our minimum asset coverage must be in excess of 1.25, where our asset coverage is defined as the summation of 80% of the book value of accounts receivable plus 60% of the book value of inventory plus 50% of the book value of net fixed assets, divided by total funded debt outstanding. In addition, we are required to maintain a minimum consolidated tangible net worth, computed on a quarterly basis, equal to approximately \$62.0 million. Finally, our debt to worth ratio, which is the ratio of our total consolidated indebtedness to our consolidated tangible net worth, cannot exceed 1.5 to 1.0 at the end of any quarter. At December 31, 2010, we were in compliance with our financial covenant requirements. In addition, commencing March 31, 2012, our maximum leverage ratio cannot exceed 3.25 and our minimum fixed charge coverage ratio must be in excess of 1.25, where the fixed charge coverage ratio is defined as the ratio of the aggregate of our trailing 12 month consolidated EBITDA plus our lease or rent expense minus our taxes based on income and payable in cash, divided by the sum of our consolidated interest charges plus our lease or rent expenses plus our scheduled principal payments and dividends, computed over the previous period.

Under the credit facility, our cumulative capital expenditures beginning in 2008 cannot exceed the sum of \$5.0 million plus \$1.25 million per quarter, on a cumulative basis, plus an allowance for our PowerSecure subsidiary recurring revenue projects generated after December 31, 2007. The credit facility contains other representations and warranties and affirmative and negative covenants, including restrictions with respect to liens, indebtedness, loans and investments, material changes in our business, asset sales or leases or transfers of assets, restricted payments such as distributions and dividends, mergers or consolidations and transactions with affiliates.

Upon the sale of any of our assets or the assets of our subsidiaries other than in the ordinary course of business, or the public or private sale of any equity or debt other than equity issuances where the aggregate proceeds do not exceed \$10.0 million, we are required to use the net proceeds thereof to repay any indebtedness then outstanding under the credit facility, except for certain reinvestment provisions.

Our obligations under the credit facility are secured by guarantees and security agreements by each of our active subsidiaries, including but not limited to our PowerSecure subsidiary and WaterSecure. The guarantees guaranty all of our obligations under the credit facility, and the security agreements grant to the lenders a first priority security interest in virtually all of the assets of each of the parties to the credit agreement.

The credit agreement also contains customary events of default, including payment defaults, breach of representations and warranties, covenant defaults, cross-defaults, certain bankruptcy or insolvency events, judgment defaults and certain ERISA-related events.

The maximum balance outstanding on the credit facility during the year ended December 31, 2010 was \$10.0 million. The balance outstanding on the credit facility at December 31, 2010 was \$5.0 million, which is the same balance outstanding at March 10, 2011. At December 31, 2009, there were no balances outstanding under the credit facility. Under the amended provisions of our credit facility, we currently have \$20.0 million available to borrow under the credit facility. However, the availability of this capital under our credit facility includes restrictions on the use of proceeds, and is dependent upon our ability to satisfy certain financial and operating covenants, as described above.

Term Credit Facility – In January 2008, we entered into a \$2.6 million term credit agreement with Citibank, for the purpose of financing a portion of the purchase price of our Wake Forest, North Carolina principal executive offices and the offices of our PowerSecure subsidiary. This term credit facility contained virtually the same terms, and was secured by the same collateral, including security interest and guarantees, as our revolving credit facility, but did not reduce our available borrowings under the revolving credit facility. In November 2008, we used approximately \$2.5 million of cash on hand to repay the outstanding balance of, and to terminate, the term credit agreement.

9. Capital Lease Obligations

We have a capital lease with SunTrust Equipment Finance and Leasing, an affiliate of SunTrust Bank, from the sale and leaseback of distributed generation equipment placed in service at customer locations. We received \$5.9 million from the sale of the equipment in December 2008 which we are repaying under the terms of the lease with monthly principal and interest payments of \$85 over a period of 84 months. At the expiration of the term of the lease in December 2015,

we have the option to purchase the equipment for \$1, assuming no default under the lease by us has occurred and is then continuing. The lease is guaranteed by us under an equipment lease guaranty. The lease and the lease guaranty constitute permitted indebtedness under our current credit agreement.

The proceeds of the lease financing were used to finance our PowerSecure subsidiary's recurring revenue projects. We account for the lease financing as a capital lease in our consolidated financial statements in accordance with generally accepted accounting principles.

The lease provides our PowerSecure subsidiary with limited rights, subject to the lessor's approval which will not be unreasonably withheld, to relocate and substitute equipment during its term. The lease contains representations and warranties and covenants relating to the use and maintenance of the equipment, indemnification and events of default customary for leases of this nature. The lease also grants to the lessor certain remedies upon a default, including the right to cancel the lease, to accelerate all rent payments for the remainder of the term of the lease, to recover liquidated damages, or to repossess and re-lease, sell or otherwise dispose of the equipment.

Under the lease guaranty, we have unconditionally guaranteed the obligations of our PowerSecure subsidiary under the lease for the benefit of the lessor. The balance of our capital lease obligations shown in the consolidated balance sheet at December 31, 2010 and 2009 consist primarily of our obligations under the equipment lease described above.

The scheduled annual payments on our capital lease obligations are as follows:

<u>Year Ending December 31:</u>	<u>Scheduled Payments</u>
2011	\$ 1,016
2012	1,016
2013	1,015
2014	1,015
2015	<u>1,015</u>
Total minimum lease payments	5,077
Less: Interest included in the lease payments	<u>634</u>
Present value of minimum lease payments	<u>\$ 4,443</u>

10. Commitments and Contingencies

Other Matters – From time to time, we hire employees that are subject to restrictive covenants, such as non-competition agreements with their former employers. We comply, and require our employees to comply, with the terms of all known restrictive covenants. However, we have in the past and may in the future receive claims and demands by some former employers alleging actual or potential violations of these restrictive covenants. While we do not believe any pending claims have merit, we cannot provide any assurance of the outcome of these claims.

From time to time, in the ordinary course of business we encounter performance issues with component parts that affect the performance of our distributed generation systems, switchgear

systems, utility infrastructure products, engines, generators, alternators, breakers, fuel systems, LED and other lighting products, electrical circuit boards, power drivers, and other complex electrical products. While we strive to utilize high quality component parts from reputable suppliers, and to back-up their quality and performance with manufacturers' warranties, even the best parts and components have performance issues from time to time, and these performance issues create significant financial and operating risks to our business, operations and financial results. Because we regularly develop new products and technical designs, we often incorporate component parts into these new products in configurations, for uses, and in environments, for which limited experience exists and that exposes us to performance risks which may not be covered by warranties. As we strive to bring solutions to customers with unique capabilities that provide performance and cost advantages, from time-to-time we use new suppliers and new products for applications where track record of performance does not exist, or is difficult to ascertain. Although we believe our suppliers' warranties cover many of these performance issues, from time to time we face disputes with our suppliers with respect to those performance issues and their warranty obligations. Additionally, the outcome of any warranty claims is inherently difficult to predict due to the uncertainty of technical solutions, cost, customer requirements, and the uncertainty inherent in litigation and disputes generally, and thus there is no assurance we will not be adversely affected by these, or other performance issues with key parts and components. Moreover, from time to time performance issues are not covered by manufacturer's warranties, certain suppliers may not be financially able to fulfill their warranty obligations, and customers may also claim damages as a result of those performance issues. Also, the mere existence of performance issues, even if finally resolved with our suppliers and customers, can have an adverse effect on our reputation for quality, which could adversely affect our business.

We estimate that from time to time we have performance issues related to component parts which have a cost basis of approximately 5-20% of our estimated annual revenues, although not necessarily limited to this amount, which are installed in equipment we own and have sold to various customers across our business lines, and additional performance issues could arise in the future. In addition, the failure or inadequate performance of these components pose potential material and adverse effects on our business, operations, reputation and financial results, including reduced revenues for projects in process or future projects, reduced revenues for recurring revenue contracts which are dependent on the performance of the affected equipment, additional expenses and capital cost to repair or replace the affected equipment, inventory write-offs for defective components held in inventory, asset write-offs for company-owned systems which have been deployed, the cancellation or deferral of contracts by our customers, or claims made by our customers for damages as a result of performance issues.

Through March 10, 2011, we have experienced performance issues with two types of component parts, in particular, which we are working to resolve: 1) an instance of a supplier of a substantial distributed generation system component that has indicated it's warranty does not cover performance issues related to a component from another supplier which is in many of the distributed generation systems deployed for our customers, and 2) generators from a certain supplier which have had performance issues in a distributed generation system we own, and for which we have a performance-based recurring revenue contract that is dependent on the system's positive operating performance. In both of these instances, we are actively working to assess and correct the performance issues, and when possible, we have sought the assistance of the suppliers in resolving these issues.

Given that we are in the process of assessing and addressing these performance issues, the uncertainty regarding the assistance we may or may not receive from our suppliers, our track

record of repairing many of these types of issues as well as the inherent uncertainty in addressing technical issues specifically and disputes generally, at present we are unable to estimate the potential negative impacts from these particular items, if any, in addition to other component part performance issues discussed above. In addition, at this time we have not recorded any adjustment to our warranty reserve for these particular performance issues, other than an immaterial amount for certain minor repairs, as the estimated cost, if any, of fulfilling our warranty obligations for these performance issues within a possible range of outcomes is not determinable as of this date.

From time to time, we are involved in other disputes, claims, proceedings and legal actions arising in the ordinary course of business. We intend to vigorously defend all claims against us. Although the ultimate outcome of these proceedings cannot be accurately predicted due to the inherent uncertainty of litigation, in the opinion of management, based upon current information, no other currently pending or overtly threatened proceeding is expected to have a material adverse effect on our business, financial condition or results of operations.

Operating Leases – We lease business facilities, equipment and vehicles under operating lease agreements which specify minimum rentals. Substantially all these leases have renewal provisions. Rental expense associated with our continuing operations for the years ended December 31, 2010, 2009 and 2008 totaled \$2,852, \$1,496 and \$2,026, respectively. Future minimum rental payments under noncancelable operating leases having an initial or remaining term of more than one year are as follows:

<u>Year Ending December 31:</u>	<u>Scheduled Payments</u>
2011	\$ 1,586
2012	1,481
2013	1,343
2014	1,121
2015 and thereafter	<u>2,138</u>
Total minimum rental payments	<u>\$ 7,669</u>

Employee Benefit Plan – We have a defined contribution savings and investment plan (the “401(k) Plan”) under Section 401(k) of the Internal Revenue Code. All employees age 18 or older are eligible to participate in the 401(k) Plan. The 401(k) Plan provides for discretionary contributions by employees of up to 80% of their eligible compensation. In 2008, we made discretionary matching contributions of 50% of participant contributions, subject to a maximum of 6% of each participant’s eligible compensation. In January 2009, we amended the 401(k) Plan to temporarily eliminate discretionary contributions to highly compensated participants and to reduce discretionary contributions to all other participants. In December 2009, we amended the 401(k) Plan to reinstate matching contributions at the previous levels to all participants commencing January 1, 2010. Our 401(k) Plan expense associated with our continuing operations for the years ended December 31, 2010, 2009 and 2008 was \$372, \$91 and \$323, respectively.

Employment Agreements – We have employment and non-competition agreements with Sidney Hinton, our President and Chief Executive Officer (the “Hinton Employment Agreement”) and with Christopher Hutter, our Executive Vice President and Chief Financial Officer (the “Hutter

Employment Agreement”). As amended, these employment agreements provide for base salary, bonus payments under our executive incentive compensation plan, grants of restricted shares of our common stock (see Note 13), severance benefits depending on the circumstances of the employee termination, and disability insurance policies. In addition, the Hinton Employment Agreement also provides for a \$5.0 million life insurance policy and deferred compensation payments that we have funded through an annuity that become payable upon his retirement (see Note 7). The Hinton Employment Agreement expires December 31, 2015 and the Hutter Employment Agreement expires December 10, 2012, each with automatic successive one-year renewal periods unless either we or the officer gives notice of termination.

We also have employment agreements with certain other executive officers and with other key employees which provide for base salary, restricted stock grants, incentive compensation, “change-in-control” provisions, non-competition provisions, severance arrangements, and other normal employment terms and conditions.

Related Party Distributorship and Non-Compete Agreement – In August 2009, we entered into a distributorship and non-compete arrangement with Apex Controls, Inc. (“Apex”) and its principal, Jonathan Hinton (“J. Hinton”), a former officer of our PowerSecure subsidiary and the son of Sidney Hinton, our President and Chief Executive Officer. We entered into this arrangement in order to enhance our ability to accelerate sales of our EfficientLights product line and to restrict Apex and J. Hinton from competing with us through October 1, 2015. Under this arrangement, we appointed Apex as our independent, non-exclusive distributor, primarily to sell and distribute our EfficientLights LED lighting solutions for refrigerated cases. Under this arrangement, we have the right of first refusal to purchase Apex upon the proposed sale of 50% or more of the assets or equity of Apex, on the same basis as the proposed purchaser.

In consideration for services and the covenants and obligations of Apex and J. Hinton under the arrangement, our PowerSecure subsidiary will pay Apex a commission, on an as-collected basis, for sales of our PowerSecure subsidiary’s products and services generated by Apex. In addition, our PowerSecure subsidiary paid J. Hinton \$200 upon entering into the arrangement and agreed to make additional payments of \$200 in January 2010 and \$100 annually from 2011 through 2015. During the years ended December 31, 2010 and 2009, we recognized expense of \$148 and \$49, respectively, related to the arrangement.

The distributorship and non-compete arrangement will continue until October 1, 2015, although it may be terminated earlier upon a breach or default or upon other adverse events related to Apex. Our payment obligations continue and could accelerate upon a sale of our PowerSecure subsidiary, and terminate upon the death of J. Hinton. The arrangement was approved by the Audit Committee of our Board of Directors.

11. Income Taxes

We record a deferred tax liability or asset (net of a valuation allowance) in our financial statements by applying the provisions of applicable laws to measure the deferred tax consequences of temporary differences that will result in net taxable or deductible amounts in future years as a result of events recognized in the financial statements in the current or preceding years.

The income tax benefit (provision) included in the accompanying consolidated statements of operations represents changes in our net deferred tax assets, federal alternative minimum tax and

state income taxes in various state jurisdictions in which we have taxable activities. The following table summarizes our income tax benefit (provision) for the years ended December 31:

	<u>2010</u>	<u>2009</u>	<u>2008</u>
Current:			
Federal	\$ 218	\$ (13)	\$ (160)
State	(296)	(548)	(919)
Total current	<u>(78)</u>	<u>(561)</u>	<u>(1,079)</u>
Deferred:			
Federal	(544)	(144)	305
State	96	374	45
Total deferred	<u>(448)</u>	<u>230</u>	<u>350</u>
Total benefit (provision)	<u>\$ (526)</u>	<u>\$ (331)</u>	<u>\$ (729)</u>

Total income tax expense applicable to our continuing operations differs from the amount computed by applying the statutory federal income tax rate to income from continuing operations before income tax expense. The following table reconciles such differences for the years ended December 31:

	<u>2010</u>	<u>2009</u>	<u>2008</u>
Federal taxes at statutory rate	34.0%	34.0%	34.0%
State taxes, net of federal benefit	13.0%	5.7%	7.7%
Permanent items	18.5%	-8.9%	1.8%
Alternative minimum tax	0.0%	3.8%	1.8%
Tax benefit for NOL, net of valuation allowance	-16.4%	-27.9%	-39.4%
True ups and other adjustments	<u>-8.4%</u>	<u>3.9%</u>	<u>2.8%</u>
Effective income tax rate for continuing operations	<u>40.7%</u>	<u>10.6%</u>	<u>8.7%</u>

The components of our federal and state deferred tax assets and liabilities at December 31, 2010 and 2009 are shown below:

	<u>2010</u>	<u>2009</u>
Deferred tax assets:		
Net operating loss carryforwards	\$ 9,340	\$ 10,164
Tax credit carryforwards	56	274
Allowance for bad debts	150	103
Restructuring charges	-	122
Equity compensation	1,609	1,288
Other	<u>2,074</u>	<u>1,615</u>
Gross deferred tax assets	<u>13,229</u>	<u>13,566</u>
Deferred tax liabilities:		
Differences between book and tax basis of property and equipment and intangible assets	4,280	5,172
Investment in MM 1995-2	390	244
Other	<u>874</u>	<u>631</u>
Gross deferred tax liabilities	<u>5,544</u>	<u>6,047</u>
Net deferred tax asset	7,685	7,519
Valuation allowance and other	<u>(4,710)</u>	<u>(4,806)</u>
Deferred tax assets, net	<u>\$ 2,975</u>	<u>\$ 2,713</u>

We believe that based on all available evidence along with the anticipated generation of taxable income in 2011 and beyond, it is more likely than not that some portion of the net deferred tax assets that existed at December 31, 2010 and 2009 will be realized. Accordingly, during the year ended December 31, 2010, we released \$96 of our valuation allowance based on our current expectations regarding future taxable income. None of our valuation allowance was released during the year ended December 31, 2009. The deferred tax asset for net operating loss carryforwards at December 31, 2010 and 2009 does not include \$115 and \$22, respectively, that relates to the tax effect of stock options for which the benefit will not be recognized in stockholders' equity until the period that the amounts decrease taxes payable. The related \$340 and \$64 tax deduction at December 31, 2010 and 2009 are included in the unused net operating loss below.

At December 31, 2010, we had unused federal net operating losses to carry forward against future years' taxable income of \$25,813 and various state carryforwards that expire in various amounts from 2011 to 2027.

We or our subsidiaries file income tax returns in the U.S. federal jurisdiction and in various state jurisdictions. The process of filing income tax returns requires us, in consultation with our tax advisors, to make judgments regarding how we will apply intricate and often ambiguous laws, regulations, administrative rulings and court precedents. If and when the tax returns are audited by taxing authorities, these judgments may be questioned or disallowed in total or in part. As a result, when determining the accounting entries necessary to accurately reflect income taxes currently payable and/or refundable, we must make assumptions regarding the likelihood of success in defending our judgments in the event of audits.

We allocate a portion of our corporate expenses to our subsidiaries in the state income tax returns that they are required to file. The allocation of corporate expenses, and the amounts of such allocations, to our subsidiaries for state income tax purposes is an interpretation of state income tax regulations that we believe are proper and appropriate, however, these allocations may be challenged by state taxing authorities and may be disallowed, in whole or in part, upon audit by

such taxing authorities. Accordingly, we have recorded a liability for our estimate of taxes, penalties and interest associated with this uncertain tax position. Our estimate is based on assumptions regarding the likelihood of successfully defending this tax position in an audit. We believe the allocation of a portion of our corporate expenses to our subsidiaries is our only material uncertain tax position at December 31, 2010 and 2009.

With few exceptions, we are no longer subject to U.S. federal, state and local income tax examinations by tax authorities for years prior to 2007. The following is a reconciliation of the beginning and ending amounts of unrecognized state income tax benefits:

	Unrecognized Tax Benefit
Balance at January 1, 2008	\$ 758
Current year increase (decrease) as a result of tax positions taken during the year	195
Reductions as a result of a lapse of the applicable statute of limitations	<u>(84)</u>
Balance at December 31, 2008	869
Current year increase (decrease) as a result of tax positions taken during the year	668
Reductions as a result of a lapse of the applicable statute of limitations	<u>(41)</u>
Balance at December 31, 2009	1,496
Current year increase (decrease) as a result of tax positions taken during the year	331
Reductions as a result of a lapse of the applicable statute of limitations	<u>(124)</u>
Balance at December 31, 2010	<u>\$ 1,703</u>

We believe nearly all of our unrecognized tax benefits would, if recognized, affect our effective tax rate.

We recognize interest and penalties related to our tax contingencies as income tax expense. The total amount of interest and penalties recognized in the accompanying consolidated statement of operations for the years ended December 31, 2010, 2009 and 2008 is \$195, \$239 and \$77, respectively. The total amount of interest and penalties recognized in the accompanying consolidated balance sheet at December 31, 2010 and 2009 is \$642 and \$510, respectively. We expect that the unrecognized tax benefit associated with our corporate expense allocation will decrease slightly in 2011 although we are not able, at this time, to reasonably estimate the range of the possible change.

12. Capital Stock

Stockholder Rights Plan – On December 12, 1991, our board of directors adopted a Stockholder Rights Plan, which was amended and restated on October 25, 2001 in order to extend, renew and modify its terms (as amended and restated, the “Rights Plan”), to protect stockholder interests against takeover strategies that may not provide maximum shareholder value. Pursuant to the Rights Plan, a dividend of one preferred stock purchase right (“Right”) was issued with respect to each share of our common stock outstanding on December 9, 1991, and attaches to each share of common stock we issued thereafter. No separate certificates representing the Rights have been issued. Each Right entitles the holder to purchase one one-hundredth of a share of our Series C Preferred Stock at an exercise price of \$15.00 per share under certain circumstances. This portion of a Series C preferred share provides the holder with approximately the same dividend, voting and liquidation rights as one share of common stock. If any person or group (referred to as an “Acquiring Person”) becomes the beneficial owner of, or announces a tender offer that would result in the Acquiring Person becoming the beneficial owner of, 15% or more of our common stock (subject to certain exceptions), then each Right, other than Rights held by the Acquiring Person which become void, will become exercisable for our common stock, or of the Acquiring Person in the case where the Acquiring Person acquires us, having a then current market value of twice the exercise price of the Right. At the option of the board of directors, the Rights may be redeemed for \$0.01 per Right or exchanged for shares of our common stock at the exchange rate of one share per Right, in each case subject to adjustment. Until a Right is exercised, the holder thereof, as such, has no rights as a stockholder. The Rights will expire on November 30, 2011, unless such date is extended prior thereto by the board of directors.

Stock Warrants – In May 2004, we completed a private placement to institutional and accredited investors of 3,510,548 shares of our common stock and warrants to purchase 1,053,164 shares of our common stock (the “2004 Private Placement”), raising gross proceeds of \$10,883. The warrants issued in the 2004 Private Placement had an exercise price of \$3.41 per share of common stock and were set to expire in May 2009. At December 31, 2008, 91,001 warrants remained outstanding. These outstanding warrants were exercised in April 2009 resulting in proceeds of \$307 to us and the issuance of 91,001 shares of our common stock during the year ended December 31, 2009.

13. Share-Based Compensation

We recognize compensation expense for all share-based awards made to employees and directors based on estimated fair values on the date of grant.

Stock Plans – Historically, we have granted stock options and restricted stock awards to employees and directors under various stock plans. We currently maintain two stock plans.

Under our 1998 Stock Incentive Plan, as amended (the “1998 Stock Plan”), we granted incentive stock options, non-qualified stock options, stock appreciation rights, restricted stock, performance awards and other stock-based awards to our officers, directors, employees, consultants and advisors for shares of our common stock. Stock options granted under the 1998 Stock Plan contained exercise prices not less than the fair market value of our common stock on the date of grant, and had a term of 10 years from the date of grant. Nonqualified stock option grants to our directors under the 1998 Stock Plan generally vested over periods up to two years. Qualified stock option grants to our employees under the 1998 Stock Plan generally vested over periods up to five years. The 1998 Stock Plan expired on June 12, 2008, and no additional awards may be

made under the 1998 Stock Plan, although awards granted prior to such date will remain outstanding and subject to the terms and conditions of those awards.

In March 2008, our board of directors adopted the PowerSecure International, Inc. 2008 Stock Incentive Plan (the "2008 Stock Plan"), which was approved by our stockholders at the Annual Meeting of Stockholders held on June 9, 2008. The 2008 Stock Plan authorizes our board of directors to grant incentive stock options, non-qualified stock options, stock appreciation rights, restricted stock, performance awards and other stock-based awards to our officers, directors, employees, consultants and advisors for up to an aggregate of 600,000 shares of our common stock. Stock options granted under the 2008 Stock Plan must contain exercise prices not less than the fair market value of our common stock on the date of grant, and must contain a term not in excess of 10 years from the date of grant. The 2008 Stock Plan replaced our 1998 Stock Plan.

Stock Options – Net income for the years ended December 31, 2010, 2009 and 2008 includes \$381, \$556 and \$656, respectively, of pre-tax compensation costs related to outstanding stock options. The after-tax compensation cost of outstanding stock options for the years ended December 31, 2010, 2009 and 2008 was \$232, \$339 and \$400, respectively. All of the stock option compensation expense is included in general and administrative expenses in the accompanying consolidated statements of operations.

A summary of option activity for the year ended December 31, 2010 is as follows:

	<u>Shares</u>	<u>Weighted Average Exercise Price</u>	<u>Weighted Average Remaining Contractual Term (years)</u>	<u>Aggregate Intrinsic Value</u>
Balance, December 31, 2009	1,627	\$ 5.18		
Granted-Directors	-	-		
Granted-Employees	81	9.51		
Exercised	(435)	3.35		
Expired	(5)	17.38		
Forfeited	(21)	9.28		
Balance, December 31, 2010	<u>1,247</u>	<u>\$ 5.98</u>	<u>4.92</u>	<u>\$ 1.80</u>
Exercisable, December 31, 2010	<u>997</u>	<u>\$ 5.75</u>	<u>4.07</u>	<u>\$ 2.03</u>

A summary of option activity for the year ended December 31, 2009 is as follows:

	<u>Shares</u>	<u>Weighted Average Exercise Price</u>	<u>Weighted Average Remaining Contractual Term (years)</u>	<u>Aggregate Intrinsic Value</u>
Balance, December 31, 2008	1,708	\$ 5.21		
Granted-Directors	-	-		
Granted-Employees	43	6.41		
Exercised	(64)	2.22		
Expired	(6)	6.88		
Forfeited	(54)	10.62		
Balance, December 31, 2009	<u>1,627</u>	<u>\$ 5.18</u>	<u>4.87</u>	<u>\$ 2.03</u>
Exercisable, December 31, 2009	<u>1,334</u>	<u>\$ 4.85</u>	<u>4.15</u>	<u>\$ 2.36</u>

A summary of option activity for the year ended December 31, 2008 is as follows:

	<u>Shares</u>	<u>Weighted Average Exercise Price</u>	<u>Weighted Average Remaining Contractual Term (years)</u>	<u>Aggregate Intrinsic Value</u>
Balance, December 31, 2007	1,728	\$ 5.34		
Granted-Directors	-	-		
Granted-Employees	232	4.31		
Exercised	(169)	2.68		
Canceled	-	-		
Forfeited	(83)	10.85		
Balance, December 31, 2008	<u>1,708</u>	<u>\$ 5.21</u>	<u>5.71</u>	<u>\$ (1.92)</u>
Exercisable, December 31, 2008	<u>1,306</u>	<u>\$ 4.49</u>	<u>4.80</u>	<u>\$ (1.20)</u>

No options were granted to our directors during the three years ended December 31, 2010. The weighted average grant date fair value of the options granted to employees during the years ended December 31, 2010, 2009 and 2008 was \$4.28, \$3.30 and \$2.55, respectively. The fair value was measured using the Black-Scholes valuation model with the following assumptions for the years ended December 31:

	<u>2010</u>	<u>2009</u>	<u>2008</u>
Expected stock price volatility	49.6%	57.4%	65.0%
Risk Free interest rate	2.00%	2.39%	1.84%
Annual dividends	\$ -	\$ -	\$ -
Expected life - employees	5 years	5 years	5 years
Expected life - directors	na	na	na

The fair value of the stock option grants are amortized over their respective service periods using the straight-line method and assuming a forfeiture rate of 5%.

At December 31, 2010 and 2009, there was \$731 and \$820, respectively, of total unrecognized compensation costs related to stock options. These costs at December 31, 2010 are expected to be recognized over a weighted average period of 1.78 years.

The total intrinsic value of stock options exercised during the years ended December 31, 2010, 2009 and 2008 was \$2,765, \$213 and \$1,023, respectively. Cash received from stock option exercises for the years ended December 31, 2010, 2009 and 2008 was \$1,457, \$141 and \$501, respectively. The tax benefit realized on the 2010, 2009 and 2008 stock option exercises was \$177, \$48 and \$263, respectively. The total grant date fair value of stock options vested during the years ended December 31, 2010, 2009 and 2008 was \$532, \$604 and \$820, respectively.

Restricted Stock Awards – Net income for the years ended December 31, 2010, 2009 and 2008 includes \$1,561, \$1,567 and \$1,728, respectively, of pre-tax compensation costs related to outstanding restricted stock awards granted to directors, certain officers and our employees. All of the restricted stock award compensation expense during the years ended December 31, 2010, 2009 and 2008 is included in general and administrative expenses in the accompanying consolidated statements of operations. In December 2009, our Board of Directors, upon the recommendation of the Compensation Committee, amended certain restricted stock agreements to modify the vesting conditions for 193,500 unvested performance-based restricted shares related to fiscal 2009, 2010 and 2011 in order to reflect new performance goals that it deemed to be more appropriate for those years under the changed conditions and circumstances of the Company and the economy. The 193,500 amended performance-based restricted shares are reflected as cancelled and granted in the following table during the year ended December 31, 2009. A summary of unvested restricted stock award activity for the three years ended December 31, 2010 is as follows:

	Unvested Restricted Shares	Weighted Average Grant Date Fair Value
Balance, January 1, 2008	641	\$ 12.48
Granted-Directors	34	6.98
Granted-Officers	-	-
Granted-Employees	28	7.45
Vested	(75)	11.62
Forfeited	-	-
	<hr/>	
Balance, December 31, 2008	628	\$ 12.06
Granted-Directors	43	4.65
Granted-Officers	194	7.97
Granted-Employees	-	-
Vested	(104)	9.96
Forfeited	(6)	8.50
Cancelled	(194)	12.49
	<hr/>	
Balance, December 31, 2009	561	\$ 10.36
Granted-Directors	21	9.56
Granted-Officers	-	-
Granted-Employees	-	-
Vested	(104)	7.25
Forfeited	-	-
	<hr/>	
Balance, December 31, 2010	<u>478</u>	<u>\$ 11.00</u>

Restricted shares are subject to forfeiture and cannot be sold or otherwise transferred until they vest. If the holder of the restricted shares leaves us before the restricted shares vest, other than due to termination by us without cause, then any unvested restricted shares will be forfeited and returned to us. The restricted shares granted to directors vest in equal amounts over a period of one or three years, depending on the nature of the grant. The restricted shares granted to employees other than officers vest in equal annual amounts over five years. A total of 322,500 unvested restricted shares issued to officers cliff vest in 2012, while the remaining 129,000 unvested performance-based restricted shares issued to officers vest in equal annual amounts in 2011 and 2012, assuming certain performance conditions are achieved. All restricted and unvested shares will automatically vest upon a change in control.

The fair value of employee and director restricted shares along with the cliff vesting restricted shares granted to officers are being amortized on a straight-line basis over the vesting period. The fair value of the performance-based restricted shares is expensed as the achievement of the performance criteria becomes probable and the related service period conditions are met. At December 31, 2010, the balance of unrecognized compensation cost related to unvested restricted shares was \$1,999, which, assuming all future performance criteria will be met, we expect will be recognized over a weighted average period of approximately 1.5 years.

14. Segment and Related Information

Our operating segments represent components of our business for which discrete financial information is available and is reviewed regularly by the chief operating decision-maker, or decision-making group, to evaluate performance and make operating decisions. We conduct our operations through two operating segments: Energy and Smart Grid Solutions, and Energy Services. Our reportable segments are strategic business units that offer different products and services and serve different customer bases. They are managed separately because each business requires different technology and marketing strategies. Our Southern Flow business, which previously operated in our Energy Services segment, was sold in January 2011 pursuant to the execution of a purchase agreement in December 2010. Accordingly, the Southern Flow business has been discontinued and the results of its operations are excluded from our Energy Services segment for all periods presented in the information below.

Energy and Smart Grid Solutions – Through our PowerSecure subsidiary we serve utilities and commercial, institutional, and industrial customers in the areas of Interactive Distributed Generation®, Utility Infrastructure and Energy Efficiency. Each of these PowerSecure subsidiary business units operates in a distinct market with distinct technical disciplines, but shares a common customer base, sales force, and administrative infrastructure with other PowerSecure subsidiary products and services and which we grow through shared resources and customer relationships. Accordingly, these units are included within our Energy and Smart Grid Solutions segment results; and

Energy Services – Through our WaterSecure subsidiary we serve customers in the oil and natural gas production business with water processing and disposal services. WaterSecure, through its equity investment in MM 1995-2, provides water processing and disposal for oil and natural gas producers. The operations of our Southern Flow subsidiary, which previously was included in this segment, were sold in January 2011 pursuant to the execution of a purchase agreement in December 2010. Accordingly, the Southern Flow business has been discontinued and the results of its operations are excluded from our Energy Services segment for all periods presented in the information below.

The accounting policies of the reportable segments are the same as those described in Note 1 of the Notes to Consolidated Financial Statements. We evaluate the performance of our operating segments based on income (loss) before income taxes. There are no intersegment sales.

Summarized financial information concerning our reportable segments is shown in the following table. Unallocated corporate cost amounts include corporate overhead, other income and interest expense which, for purposes of evaluating the operations of our segments, are not allocated to our segment activities. Total asset amounts exclude intercompany receivable balances eliminated in consolidation.

Year Ended December 31, 2010

	Energy and Smartgrid Solutions	Energy Services	Unallocated Corporate Costs	Total
Revenues	\$ 97,514	\$ -	\$ -	\$ 97,514
Cost of sales	62,220	-	-	62,220
Gross profit	35,294	-	-	35,294
Operating expenses:				
General and administrative	23,984	-	5,355	29,339
Selling, marketing and service	5,154	-	-	5,154
Depreciation and amortization	2,675	73	6	2,754
Total operating expenses	31,813	73	5,361	37,247
Operating income (loss)	3,481	(73)	(5,361)	(1,953)
Other income and (expenses):				
Equity income	-	3,182	-	3,182
Management fees	-	583	-	583
Interest income and other income	-	-	99	99
Interest expense	(341)	-	(278)	(619)
Income (loss) before income taxes	\$ 3,140	\$ 3,692	\$ (5,540)	\$ 1,292
Total capital expenditures	\$ 6,131	\$ -	\$ 1	\$ 6,132
Total investment in unconsolidated affiliate	\$ -	\$ 4,346	\$ -	\$ 4,346
Total assets	\$ 93,553	\$ 4,497	\$ 22,479	\$ 120,529

Year Ended December 31, 2009

	Energy and Smartgrid Solutions	Energy Services	Unallocated Corporate Costs	Total
Revenues	\$ 85,426	\$ -	\$ -	\$ 85,426
Cost of sales	54,231	-	-	54,231
Gross profit	31,195	-	-	31,195
Operating expenses:				
General and administrative	19,127	-	5,042	24,169
Selling, marketing and service	3,927	-	-	3,927
Depreciation and amortization	2,065	74	5	2,144
Total operating expenses	25,119	74	5,047	30,240
Operating income (loss)	6,076	(74)	(5,047)	955
Other income and (expenses):				
Equity income	-	2,167	-	2,167
Management fees	-	447	-	447
Interest income and other income	3	-	158	161
Interest expense	(334)	-	(273)	(607)
Income (loss) before income taxes	\$ 5,745	\$ 2,540	\$ (5,162)	\$ 3,123
Total capital expenditures	\$ 2,591	\$ -	\$ 2	\$ 2,593
Total investment in unconsolidated affiliate	\$ -	\$ 3,974	\$ -	\$ 3,974
Total assets	\$ 78,818	\$ 16,749	\$ 15,910	\$ 111,477

	Year Ended December 31, 2008			Total
	Energy and Smartgrid Solutions	Energy Services	Unallocated Corporate Costs	
Revenues	\$ 115,993	\$ -	\$ -	\$ 115,993
Cost of sales	77,550	-	-	77,550
Gross profit	<u>38,443</u>	<u>-</u>	<u>-</u>	<u>38,443</u>
Operating expenses:				
General and administrative	22,113	7	5,008	27,128
Selling, marketing and service	5,325	-	-	5,325
Depreciation and amortization	<u>1,774</u>	<u>67</u>	<u>6</u>	<u>1,847</u>
Total operating expenses	<u>29,212</u>	<u>74</u>	<u>5,014</u>	<u>34,300</u>
Operating income (loss)	9,231	(74)	(5,014)	4,143
Other income and (expenses):				
Equity income	-	3,490	-	3,490
Management fees	-	556	-	556
Interest income and other income	82	-	382	464
Interest expense	<u>(140)</u>	<u>-</u>	<u>(147)</u>	<u>(287)</u>
Income (loss) before income taxes	<u>\$ 9,173</u>	<u>\$ 3,972</u>	<u>\$ (4,779)</u>	<u>\$ 8,366</u>
Total capital expenditures	<u>\$ 17,896</u>	<u>\$ 710</u>	<u>\$ -</u>	<u>\$ 18,606</u>

To date, nearly all our revenues have been derived from sales to customers within the United States.

15. Unaudited Quarterly Consolidated Financial Data

The following table illustrates selected unaudited consolidated quarterly statement of operations data for the years ended December 31, 2010 and 2009. In our opinion, this unaudited information has been prepared on substantially the same basis as the consolidated financial statements appearing elsewhere in this Annual Report on Form 10-K and includes all adjustments (consisting of normal recurring adjustments) necessary to present fairly the unaudited consolidated quarterly data. The unaudited consolidated quarterly data should be read together with the audited consolidated financial statements and notes thereto appearing elsewhere in this Annual Report on Form 10-K. The results for any quarter are not necessarily indicative of results for any future period.

	Quarter in 2010			
	First	Second	Third	Fourth
Total revenues	\$ 20,460	\$ 29,733	\$ 26,316	\$ 21,005
Operating income (loss)	17	388	(958)	(1,400)
Other income (expense), net	43	26	(17)	11
Equity income	1,030	807	598	747
Income taxes	(205)	(228)	(42)	(51)
Income (loss) from continuing operations	885	993	(419)	(693)
Discontinued operations:				
Income from operations	519	291	777	956
Net income	1,404	1,284	358	263
Less: Income attributable to noncontrolling interest	(187)	40	132	168
Income attributable to PowerSecure International	\$ 1,217	\$ 1,324	\$ 490	\$ 431
Basic earnings per common share:				
Income (loss) from continuing operations	\$ 0.04	\$ 0.06	\$ (0.01)	\$ (0.03)
Income from discontinued operations	0.03	0.01	0.04	0.05
Basic earnings per common share	<u>\$ 0.07</u>	<u>\$ 0.07</u>	<u>\$ 0.03</u>	<u>\$ 0.02</u>
Diluted earnings per common share:				
Income (loss) from continuing operations	\$ 0.04	\$ 0.06	\$ (0.01)	\$ (0.03)
Income from discontinued operations	0.03	0.01	0.04	0.05
Diluted earnings per common share	<u>\$ 0.07</u>	<u>\$ 0.07</u>	<u>\$ 0.03</u>	<u>\$ 0.02</u>
	Quarter in 2009			
	First	Second	Third	Fourth
Total revenues	\$ 15,215	\$ 20,671	\$ 23,579	\$ 25,961
Operating income (loss)	(2,058)	16	1,753	1,244
Other income (expense), net	(17)	(8)	(2)	28
Equity income	477	401	429	860
Income taxes	-	(2)	(407)	78
Income (loss) from continuing operations	(1,598)	407	1,773	2,210
Discontinued operations:				
Income (loss) from operations	496	610	430	(23)
Net income (loss)	(1,102)	1,017	2,203	2,187
Less: Income attributable to noncontrolling interest	(34)	(331)	(549)	(598)
Income (loss) attributable to PowerSecure International	\$ (1,136)	\$ 686	\$ 1,654	\$ 1,589
Basic earnings per common share:				
Income (loss) from continuing operations	\$ (0.10)	\$ -	\$ 0.07	\$ 0.09
Income from discontinued operations	0.03	0.04	0.03	-
Basic earnings per common share	<u>\$ (0.07)</u>	<u>\$ 0.04</u>	<u>\$ 0.10</u>	<u>\$ 0.09</u>
Diluted earnings per common share:				
Income (loss) from continuing operations	\$ (0.10)	\$ -	\$ 0.07	\$ 0.09
Income from discontinued operations	0.03	0.04	0.02	-
Diluted earnings per common share	<u>\$ (0.07)</u>	<u>\$ 0.04</u>	<u>\$ 0.09</u>	<u>\$ 0.09</u>

* * * * *

SCHEDULE II

POWERSECURE INTERNATIONAL, INC.

VALUATION AND QUALIFYING ACCOUNTS
 Years Ended December 31, 2010, 2009 and 2008
 (In thousands)

<u>Description</u>	<u>Balance at Beginning of Period</u>	<u>Additions: Charged to Operating Expenses</u>	<u>Deductions: Write-offs</u>	<u>Balance at End of Period</u>
Allowance for doubtful accounts:				
Year ended December 31, 2010.....	\$ 299	\$ 177	\$ (61) (1)	\$ 415
Year ended December 31, 2009.....	276	53	(30) (1)	299
Year ended December 31, 2008.....	262	216	(202) (1)	276
Inventory reserve:				
Year ended December 31, 2010.....	\$1,777	\$ 269	\$(254)(2)	\$1,792
Year ended December 31, 2009.....	211	1,618	(52)(2)	1,777
Year ended December 31, 2008.....	128	122	(39)(2)	211

(1) Represents amounts written off as uncollectible, less recoveries.

(2) Represents amounts written off against reserve, less recoveries.

SIGNATURES

Pursuant to the requirements of Section 13 or 15(d) of the Securities Exchange Act of 1934, the Registrant has duly caused this Report to be signed on its behalf by the undersigned, thereunto duly authorized.

POWERSECURE INTERNATIONAL, INC.

By: /s/ SIDNEY HINTON

Sidney Hinton
President and Chief Executive Officer

Date: March 10, 2011

POWER OF ATTORNEY

KNOW ALL MEN BY THESE PRESENTS, that each person whose signature appears below hereby constitutes and appoints Sidney Hinton, Christopher T. Hutter and Paul R. Hess, jointly and severally, as his true and lawful attorneys-in-fact, each with the power of substitution, for him and in his name, place and stead, in any and all capacities, to sign any and all amendments to this Report, and to file the same, with exhibits thereto and other documents in connection therewith, with the Securities and Exchange Commission, hereby ratifying and confirming all that each of said attorneys-in-fact and agents, or his substitute or substitutes, may do or cause to be done by virtue hereof.

Pursuant to the requirements of the Securities Exchange Act of 1934, this Report has been signed below by the following persons on behalf of the Registrant and in the capacities and on the dates indicated:

<u>Signature</u>	<u>Title</u>	<u>Date</u>
<u>/s/ SIDNEY HINTON</u> Sidney Hinton	President, Chief Executive Officer and Director <i>(Principal Executive Officer)</i>	March 10, 2011
<u>/s/ CHRISTOPHER T. HUTTER</u> Christopher T. Hutter	Executive Vice President, Chief Financial Officer, Treasurer and Assistant Secretary <i>(Principal Financial Officer)</i>	March 10, 2011
<u>/s/ GARY J. ZUIDERVEEN</u> Gary J. Zuiderveen	Vice President of Financial Reporting, Controller, Principal Accounting Officer, Assistant Treasurer and Secretary <i>(Principal Accounting Officer)</i>	March 10, 2011
<u>/s/ ANTHONY D. PELL</u> Anthony D. Pell	Director	March 10, 2011
<u>/s/ KEVIN P. COLLINS</u> Kevin P. Collins	Director	March 10, 2011
<u>/s/ JOHN A. (ANDY) MILLER</u> John A. (Andy) Miller	Director	March 10, 2011
<u>/s/ THOMAS J. MADDEN III</u> Thomas J. Madden III	Director	March 10, 2011

POWERSECURE INTERNATIONAL, INC.
Form 10-K
For the Year Ended December 31, 2010

EXHIBIT INDEX

<u>Number</u>	<u>Description</u>
(2.1)	Purchase and Sale Agreement, dated as of December 30, 2010, among PowerSecure International, Inc., Southern Flow Companies, Inc., Zedi USA Inc. and Zedi Inc. (Incorporated by reference to Exhibit 2.1 to Registrant's Current Report on Form 8-K, filed January 18, 2011)
(3.1)	Second Restated Certificate of Incorporation of Registrant. (Incorporated by reference to Exhibit 4.1 to Registrant's Registration Statement on Form S-3, Registration No. 333-96369.)
(3.2)	Certificate of Ownership and Merger, as filed with the Secretary of State of the State of Delaware on August 22, 2007, merging PowerSecure International, Inc. into Registrant and amending Registrant's Second Amended and Restated Certificate of Incorporation to change the Registrant's name to PowerSecure International, Inc. (Incorporated by reference to Exhibit 3.1 to Registrant's Current Report on Form 8-K, filed August 22, 2007.)
(3.3)	Amended and Restated By-Laws of Registrant. (Incorporated by reference to Exhibit 3.1 to Registrant's Current Report on Form 8-K, filed April 10, 2009.)
(4.1)	Specimen Common Stock Certificate. (Incorporated by reference to Exhibit 4.1 to Registrant's Registration Statement on Form S-18, Registration No. 33-44558.)
(4.2)	Amended and Restated Rights Agreement, dated as of November 30, 2001, between Registrant and Computershare Investor Services, LLC. (Incorporated by reference to Exhibit 4.1 to Registrant's Registration Statement on Form 8-A/A, Amendment No. 5, filed November 30, 2001.)
(4.3)	Amendment No. 1, dated as of April 22, 2004, to Amended and Restated Rights Agreement between Registrant and ComputerShare Investor Services, LLC. (Incorporated by reference to Exhibit 10.6 to Registrant's Current Report on Form 8-K, filed May 6, 2004).
(4.4)	Amendment No. 2, dated as of March 29, 2006, to Amended and Restated Rights Agreement between Registrant and ComputerShare Investor Services, LLC. (Incorporated by reference to Exhibit 10.3 to Registrant's Current Report on Form 8-K, filed March 30, 2006).
(10.1)	Registrant's 1998 Stock Incentive Plan, amended and restated as of June 12, 2006. (Incorporated by reference to Exhibit 4.3 to Registrant's Registration Statement on Form S-8, Registration No. 333-134938.)*
(10.2)	Form of Incentive Stock Option Agreement under the Registrant's 1998 Stock Incentive Plan, as amended. (Incorporated by reference to Exhibit 10.1 to Registrant's Current Report on Form 8-K, filed August 25, 2004)*
(10.3)	Form of Non-Qualified Stock Option Agreement under the Registrant's 1998 Stock Incentive Plan, as amended. (Incorporated by reference to Exhibit 10.2 to Registrant's Current Report on Form 8-K, filed August 25, 2004)*
(10.4)	Form of Restricted Stock Agreement under the Registrant's 1998 Stock Incentive Plan, as amended. (Incorporated by reference to Exhibit 10.3 to Registrant's Current Report on Form 8-K, filed August 25, 2004)*

- (10.5) Registrant's 2008 Stock Incentive Plan. (Incorporated by reference to Exhibit 10.1 to Registrant's Registration Statement on Form S-8, Registration No. 333-151540.)
- (10.6) Form of Restricted Stock Agreement under the Registrant's 2008 Stock Incentive Plan. (Incorporated by reference to Exhibit 10.2 to Registrant's Current Report on Form 8-K, filed June 13, 2008.)
- (10.7) Form of Incentive Stock Option Agreement for Employees under the PowerSecure International, Inc. 2008 Stock Incentive Plan. (Incorporated by reference to Exhibit 10.3 to Registrant's Current Report on Form 8-K, filed June 13, 2008.)
- (10.8) Form of Non-Qualified Stock Option Agreement under the Registrant's 2008 Stock Incentive Plan. (Incorporated by reference to Exhibit 10.4 to Registrant's Current Report on Form 8-K, filed June 13, 2008.)
- (10.9) Form of Indemnification Agreement between Registrant and its directors and executive officers. (Incorporated by reference to Exhibit 10.1 to Registrant's Current Report on Form 8-K, filed April 10, 2009.)
- (10.10) Prototype - Basic Plan Document for the Metrotek - Southern Flow Savings and Investment Plan. (Incorporated by reference to Exhibit 4.7 to Registrant's Registration Statement on Form S-8, Registration No. 333-42698.)*
- (10.11) Adoption Agreement for the Metrotek - Southern Flow Savings and Investment Plan. (Incorporated by reference to Exhibit 4.8 to Registrant's Registration Statement on Form S-8, Registration No. 333-42698.)*
- (10.12) Second Amended and Restated Employment and Non-Competition Agreement, dated as of December 17, 2009, by and between PowerSecure International, Inc. and Sidney Hinton. (Incorporated by reference to Exhibit 10.1 to Registrant's Current Report on Form 8-K, filed December 21, 2009)*
- (10.13) Restricted Stock Agreement, dated as of August 15, 2007, by and between Registrant and Sidney Hinton. (Incorporated by reference to Exhibit 10.2 to Registrant's Quarterly Report on Form 10-Q for the fiscal quarter ended September 30, 2007)*
- (10.14) Amendment No. 1 to Restricted Stock Agreement, dated as of December 31, 2007, by and between Registrant and Sidney Hinton. (Incorporated by reference to Exhibit 10.1 to Registrant's Current Report on Form 8-K, filed January 7, 2008)*
- (10.15) Amendment No. 2 to Restricted Stock Agreement, dated as of December 17, 2009, by and between Registrant and Sidney Hinton. (Incorporated by reference to Exhibit 10.2 to Registrant's Current Report on Form 8-K, filed December 21, 2009)*
- (10.16) First Amended and Restated Employment and Non-Competition Agreement, dated as of December 31, 2008, by and between PowerSecure International, Inc. and Christopher T. Hutter. (Incorporated by reference to Exhibit 10.2 to Registrant's Current Report on Form 8-K, filed January 7, 2009)*
- (10.17) Restricted Stock Agreement, dated as of December 10, 2007, by and between Registrant and Christopher T. Hutter. (Incorporated by reference to Exhibit 10.2 to Registrant's Current Report on Form 8-K, filed December 12, 2007)*
- (10.18) Amendment No. 1 to Restricted Stock Agreement, dated as of December 17, 2009, by and between Registrant and Christopher T. Hutter. (Incorporated by reference to Exhibit 10.3 to Registrant's Current Report on Form 8-K, filed December 21, 2009)*
- (10.19) First Amended and Restated Employment and Non-Competition Agreement, dated as of December 31, 2008, by and between PowerSecure International, Inc. and Gary J.

- Zuiderveen. (Incorporated by reference to Exhibit 10.3 to Registrant's Current Report on Form 8-K, filed January 7, 2009)*
- (10.20) Restricted Stock Agreement, dated as of December 10, 2007, to Employment and Non-Competition Agreement by and between Registrant and Gary J. Zuiderveen. (Incorporated by reference to Exhibit 10.4 to Registrant's Current Report on Form 8-K, filed December 12, 2007)*
- (10.21) Amendment No. 1 to Restricted Stock Agreement, dated as of December 17, 2009, by and between Registrant and Gary J. Zuiderveen. (Incorporated by reference to Exhibit 10.4 to Registrant's Current Report on Form 8-K, filed December 21, 2009)*
- (10.22) PowerSecure International, Inc. 2010 Executive Incentive Compensation Plan (Incorporated by reference to Exhibit 10.1 to Registrant's Current Report on Form 8-K, filed April 19, 2010)*
- (10.23) Summary Sheet of Compensation of Non-Employee Directors. (Filed herewith.)*
- (10.24) Credit Agreement, dated as of August 23, 2007, among Registrant, the financial institutions from time to time parties thereto as lenders, and Citibank, N.A., as administrative agent. (Incorporated by reference to Exhibit 10.25 to Registrant's Annual Report on Form 10-K for the year ended December 31, 2009.)
- (10.25) First Amendment to Credit Agreement, dated as of January 17, 2008, among Registrant, the financial institutions from time to time parties thereto as lenders, and Citibank, N.A., as administrative agent. (Incorporated by reference to Exhibit 10.6 to Registrant's Current Report on Form 8-K, filed January 23, 2008.)
- (10.26) Second Amendment to Credit Agreement, dated as of May 5, 2008, among Registrant, the financial institutions from time to time parties thereto as lenders, and Citibank, N.A., as administrative agent. (Incorporated by reference to Exhibit 10.8 to Registrant's Quarterly Report on Form 10-Q for the fiscal quarter ended March 31, 2008.)
- (10.27) Third Amendment to Credit Agreement, dated as of November 13, 2008, among PowerSecure International, Inc., as borrower, Citibank, N.A., as administrative agent and lender, and SunTrust Bank and Branch Banking and Trust Company, as lenders. (Incorporated by reference to Exhibit 10.2 to Registrant's Current Report on Form 8-K, filed August 24, 2007.)
- (10.28) Fourth Amendment to Credit Agreement, dated as of November 9, 2010, among PowerSecure International, Inc., as borrower, Citibank, N.A., as administrative agent and lender, and SunTrust Bank and Branch Banking and Trust Company, as lenders. (Incorporated by reference to Exhibit 10.7 to Registrant's Current Report on Form 8-K, filed November 16, 2010.)
- (10.29) Fifth Amendment to Credit Agreement, dated as of January 14, 2011, among PowerSecure International, Inc., as borrower, Citibank, N.A., as administrative agent and lender, and Branch Banking and Trust Company, as lender. (Incorporated by reference to Exhibit 10.8 to Registrant's Current Report on Form 8-K/A, Amendment No. 1, filed March 4, 2011.)
- (10.30) Form of Security Agreement, dated as of August 23, 2007, by each of Registrant and its active subsidiaries in favor of Citibank, N.A., as administrative agent, as secured party. (Incorporated by reference to Exhibit 10.2 to Registrant's Current Report on Form 8-K filed August 24, 2007.)
- (10.31) Form of First Amendment to Security Agreement, dated as of January 17, 2008, by each of Registrant and its active subsidiaries in favor of Citibank, N.A., as

- administrative agent, as secured party. (Incorporated by reference to Exhibit 10.4 to Registrant's Current Report on Form 8-K filed January 23, 2008.)
- (10.32) Form of Guaranty, dated as of August 23, 2007, by each active subsidiary of Registrant in favor of Citibank, N.A., as administrative agent. (Incorporated by reference to Exhibit 10.3 to Registrant's Current Report on Form 8-K filed August 24, 2007.)
- (10.33) Term Credit Agreement, dated as of January 17, 2008, among Registrant, the financial institutions from time to time parties thereto as lenders, and Citibank, N.A., as administrative agent. (Incorporated by reference to Exhibit 10.32 to Registrant's Annual Report on Form 10-K for the year ended December 31, 2009.)
- (10.34) First Amendment to Term Credit Agreement, dated as of May 5, 2008, among Registrant, the financial institutions from time to time parties thereto as lenders, and Citibank, N.A., as administrative agent. (Incorporated by reference to Exhibit 10.9 to Registrant's Quarterly Report on Form 10-Q for the fiscal quarter ended March 31, 2008.)
- (10.35) Form of Equipment Lease Agreement, dated as of December 22, 2008, between SunTrust Equipment Finance & Leasing Corp., as lessor, and PowerSecure, Inc., as lessee. (Incorporated by reference to Exhibit 10.1 to Registrant's Current Report on Form 8-K filed December 30, 2008.)
- (10.36) Form of Equipment Lease Guaranty, dated as of December 22, 2008, by Registrant in favor of SunTrust Equipment Finance & Leasing Corp. (Incorporated by reference to Exhibit 10.2 to Registrant's Current Report on Form 8-K filed December 30, 2008.)
- (10.37) Master Lease Agreement, dated as of November 25, 2009, between BB&T Equipment Finance Corporation, as lessor, and PowerSecure, Inc., as lessee. (Incorporated by reference to Exhibit 10.1 to Registrant's Current Report on Form 8-K filed December 2, 2009.)
- (10.38) Master Lease Guaranty, dated as of November 25, 2009, by Registrant in favor of BB&T Equipment Finance Corporation. (Incorporated by reference to Exhibit 10.2 to Registrant's Current Report on Form 8-K filed December 2, 2009.)
- (10.39) Equipment Schedule Series A No. 1, dated as of November 27, 2009, between BB&T Equipment Finance Corporation, as lessor, and PowerSecure, Inc., as lessee. (Incorporated by reference to Exhibit 10.3 to Registrant's Current Report on Form 8-K filed December 2, 2009.)
- (10.40) Rider No. 1 to Equipment Schedule Series A No. 1, dated as of November 27, 2009, between BB&T Equipment Finance Corporation, as lessor, and PowerSecure, Inc., as lessee. (Incorporated by reference to Exhibit 10.4 to Registrant's Current Report on Form 8-K filed December 2, 2009.)
- (10.41) Rider No. 2 to Equipment Schedule Series A No. 1, dated as of November 27, 2009, between BB&T Equipment Finance Corporation, as lessor, and PowerSecure, Inc., as lessee. (Incorporated by reference to Exhibit 10.5 to Registrant's Current Report on Form 8-K filed December 2, 2009.)
- (10.42) PowerSecure, Inc. Key Employee Long-Term Retention Plan. (Incorporated by reference to Exhibit 10.2 to Registrant's Quarterly Report on Form 10-Q for the fiscal quarter ended June 30, 2006.)*
- (14.1) Registrant's Code of Ethics for Principal Executive Officer and Senior Financial Officers. (Incorporated by reference to Exhibit 14.1 to Registrant's Annual Report on Form 10-K for the year ended December 31, 2003.)

- (14.2) Registrant's Code of Business Conduct and Ethics. (Incorporated by reference to Exhibit 14.2 to Registrant's Annual Report on Form 10-K for the year ended December 31, 2003.)
- (21.1) List of Subsidiaries of Registrant (Filed herewith.)
- (23.1) Consent of Hein & Associates LLP, Independent Registered Public Accounting Firm (Filed herewith.)
- (31.1) Certification of Chief Executive Officer pursuant to Rule 13a-14(a) or 15d-14(a) under the Securities Exchange Act of 1934, as amended, as adopted pursuant to Section 302 of the Sarbanes-Oxley Act of 2002 (Filed herewith.)
- (31.2) Certification of Chief Financial Officer pursuant to Rule 13a-14(a) or 15d-14(a) under the Securities Exchange Act of 1934, as amended, as adopted pursuant to Section 302 of the Sarbanes-Oxley Act of 2002 (Filed herewith.)
- (32.1) Certification of Chief Executive Officer pursuant to 18 U.S.C. Section 1350 and Rule 13a-14(b) or 15d-14(b) under the Securities Exchange Act of 1934, as amended, as adopted pursuant to Section 906 of the Sarbanes-Oxley Act of 2002 (Filed herewith.)
- (32.2) Certification of Chief Financial Officer pursuant to 18 U.S.C. Section 1350 and Rule 13a-14(b) or 15d-14(b) under the Securities Exchange Act of 1934, as amended, as adopted pursuant to Section 906 of the Sarbanes-Oxley Act of 2002 (Filed herewith.)

* Indicates management contract or compensation plan or arrangement.

PERFORMANCE GRAPH

The following graph compares the cumulative total stockholder return for the five year period ended December 31, 2010 on our common stock with the NASDAQ Composite Index (the "NASDAQ Index") and with a peer group of companies discussed below (the "Peer Group"). The measurement dates are the last trading day of each of our fiscal years in the five year period. The graph assumes that \$100.00 was invested on December 30, 2005 in our common stock, the NASDAQ Index and the Peer Group, and that any dividends were reinvested. With respect to companies in the Peer Group, the returns of each company have been weighted to reflect relative stock market capitalization at the beginning of each year. The stock price performance shown on the following graph is historical and not necessarily indicative of future stock price performance.

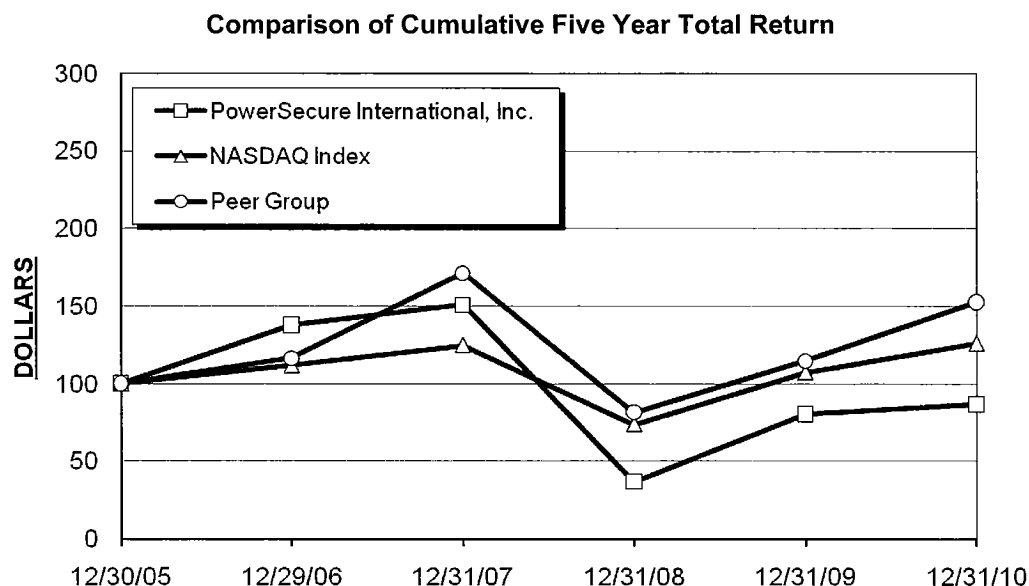

The Distributed Energy Stock Index (the "DESI") was created in 2005 by the Distributed Energy Financial Group, LLC in 2005 to provide an index consisting of companies in the alternative energy and technology industry, including PowerSecure. However, because the DESI was discontinued in December 2008, for purposes of this report we have created the Peer Group, which consists of the companies last included in the DESI, in order to provide comparative performance of those companies during the requisite five year period.

The Peer Group consists of the following companies that currently comprise the companies included in the DESI: Active Power, Inc., American Superconductor Corporation, The Andersons, Inc., Ballard Power Systems Inc., Beacon Power Corporation, C&D Technologies, Inc., Cameron International Corporation, Capstone Turbine Corporation, Comverge, Inc., Cummins Inc., Echelon Corporation, Electro Energy Inc., Emerson Electric Co., Energy Conversion Devices, Inc., Enernoc, Inc., Environmental Power Corporation, Evergreen Solar, Inc., Fuel Systems Solutions, Inc., Fuel Tech, Inc., Fuelcell Energy, Inc., Hydrogenics Corporation, Ingersoll-Rand Company Limited, International Rectifier Corporation, Itron, Inc., Magnetek, Inc., Maxwell Technologies, Inc., Mechanical Technology, Incorporated, O2Micro International Limited, Ormat Technologies, Inc., Pacific Ethanol, Inc., Plug Power Inc., Power-One, Inc., PowerSecure International, Inc., Quantum Fuel Systems Technologies Worldwide, Inc., SatCon Technology Corporation, SunPower Corporation, Suntech Power Holdings Co., Ltd., UQM Technologies, Inc. and Zoltek Companies, Inc.

	12/30/05	12/29/06	12/31/07	12/31/08	12/31/09	12/31/10
PowerSecure International, Inc.	\$100.00	\$137.65	\$150.84	\$ 36.76	\$ 80.56	\$ 86.93
Nasdaq Index	\$100.00	\$ 11.74	\$124.67	\$ 73.77	\$107.12	\$114.67
Peer Group	\$100.00	\$116.27	\$171.21	\$ 81.59	\$114.67	\$152.72

