



08001558

3/31

82- SUBMISSIONS FACING SHEET

**Follow-Up
Materials**

MICROFICHE CONTROL LABEL

[Empty box for Microfiche Control Label]

REGISTRANT'S NAME

Galting

*CURRENT ADDRESS

[Empty lines for Current Address]

**FORMER NAME

[Empty line for Former Name]

**NEW ADDRESS

[Empty lines for New Address]

PROCESSED

APR 02 2008

**THOMSON
FINANCIAL**

FILE NO. 82-

34843

FISCAL YEAR

12/31/07

* Complete for initial submissions only ** Please note name and address changes

INDICATE FORM TYPE TO BE USED FOR WORKLOAD ENTRY:

12G3-2B (INITIAL FILING)

AR/S (ANNUAL REPORT)

12G32BR (REINSTATEMENT)

SUPPL (OTHER)

DEF 14A (PROXY)

OICF/BY:

lee
3/31/08

DATE:

PALFINGER

AR-2007

10 models
3,900 employees

The Building Blocks of Success

Annual Report 2007

12-31-07 082-34843
AM/S RECEIVED
2008 MAR 31 P 1:23
FICE OF INTERNATIONAL
CORPORATE FINANCE



The sum of all parts

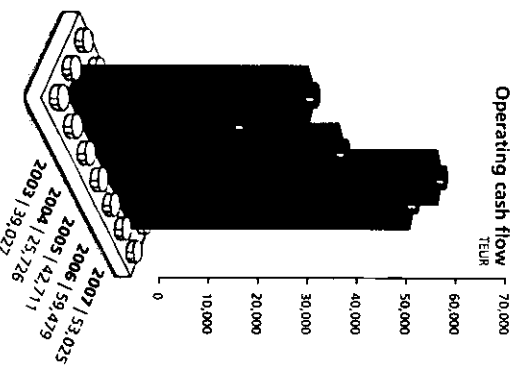
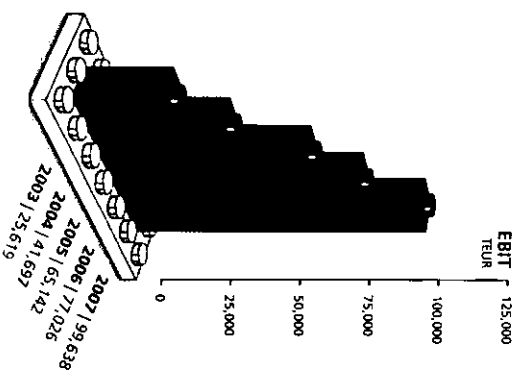

TEUR

2007

2006

2005

2004

2003

Income statement

Revenue	695,623	585,205	520,048	403,739	334,111
EBITDA	115,276	92,126	77,530	53,871	37,526
EBITDA margin	16.6%	15.7%	14.9%	13.3%	11.2%
EBIT	99,638	77,026	65,142	41,697	25,619
EBIT margin	14.3%	13.2%	12.5%	10.3%	7.7%
Profit before tax	102,392	75,583	63,926	41,168	23,880
Consolidated net profit for the year	73,978	56,603	48,143	27,391	15,192

Balance sheet

Total assets	528,314	409,366	348,591	309,286	265,505
Non-current operating assets	238,366	153,522	145,508	119,885	113,129
Net working capital (as of the reporting date)	134,700	98,637	88,241	68,870	56,821
Capital employed (as of the reporting date)	373,066	252,159	233,749	188,755	169,950
Equity	295,056	241,964	197,999	159,960	136,610
Equity ratio	55.8%	59.1%	56.8%	51.7%	51.5%
Net debt	78,694	10,195	35,750	26,877	32,372
Gearing	26.7%	4.2%	18.1%	16.8%	23.7%

Cash flow and investment

Cash flows from operating activities	53,025	59,479	42,711	25,726	39,027
Free cash flow	(23,246)	43,734	9,427	12,942	27,601
Investment in property, plant, and equipment	61,444	21,351	14,999	12,510	15,457
Depreciation, amortisation, and impairment	15,638	15,100	12,388	12,174	11,907

Payroll

Average annual payroll ¹⁾	3,860	3,443	3,087	2,563	2,293
--------------------------------------	-------	-------	-------	-------	-------

Value creation

ROCE	25.7%	25.7%	25.1%	18.2%	11.8%
ROE	29.1%	27.1%	29.8%	20.2%	12.5%
EVA	54,502	41,979	35,442	18,118	7,446
WACC	8.2%	8.4%	8.3%	8.1%	7.5%

Consolidated Group companies excluding equity shareholdings, as well as excluding apprentices, temporary workers, and workers employed for only very short periods.

Table of Contents

PALFINGER Financial Highlights	IFC
Mission Statement	3
Highlights 2007	4
Strategy	13
Management and Supervisory Boards	16
Foreword by the CEO	18
Consolidated Management Report	
Market Review	22
Economic Background	22
Industry Review	23
Competitive Environment	25
Customers and Suppliers	25
Performance of PALFINGER	29
Business Development in 2007	29
Significant Changes	31
Legal Changes in the Group Structure	33
Information According to Sec. 243a UGB	33
Group Assets, Finances, and Earnings	35
Treasury	41
Risk Report	43
Research, Development, and Innovation	47
Human Resources	51
Investor Relations	54
Corporate Governance	57
Sustainability	59
Marketing	62
Performance of the Business Divisions	65
Performance by Region	65
Performance by Product Group	68
Outlook	73
Consolidated Financial Statements as of 31 December 2007	
Consolidated Balance Sheet	76
Consolidated Income Statement	77
Consolidated Cash Flow Statement	78
Consolidated Statement of Changes in Equity	79
Notes to the Consolidated Financial Statements	80
General	80
Consolidation Principles	81
Accounting and Valuation Principles	89
Notes to the Consolidated Balance Sheet	98
Notes to the Consolidated Income Statement	116
Notes to the Consolidated Cash Flow Statement	121
Segment Reporting	121
Financial Instruments	124
Other Disclosures	130
Declaration of Legal Representatives	134
Auditor's Report	136
Report of the Supervisory Board	138
Definition of Performance Indicators	140
Corporate Locations	141
Imprint	144
PALFINGER Companies	IBC
Financial Calendar 2008	cover flap

PALFINGER Financial Highlights

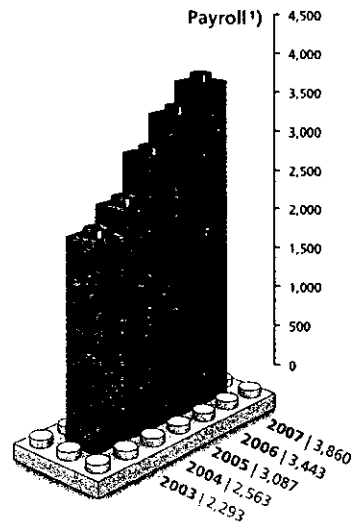
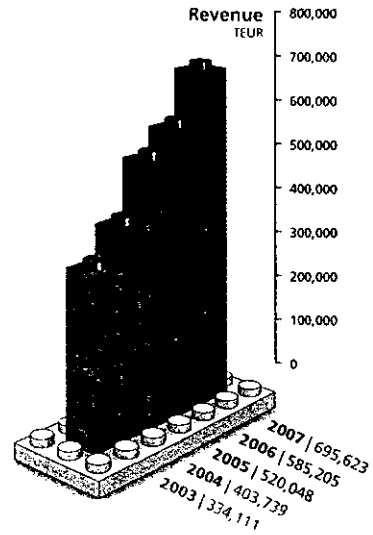

The three building blocks of success

PALFINGER stands for innovative hydraulic lifting, loading, and handling solutions at each interface of the transport chain. With our market know-how, technological skills, and the commitment of our staff we enable our customers all over the world to be more successful.

Innovation is the result of our passion for the permanent improvement of product, process, and organisation. It ensures PALFINGER's market leadership and allows it to access new business fields that broaden the base of the business.

Internationalisation ensures that our customers in all five continents receive products that conform to market standards and provides our Company with maximum independence from regional economic fluctuations while simultaneously opening up new areas of potential growth, and optimising production and logistics costs.

Diversification ensures our independence from sector-specific fluctuations, generates additional potential for growth and cross-selling, and guarantees our sales partners an optimised product portfolio.



Highlights 2007

The building blocks that made a great year

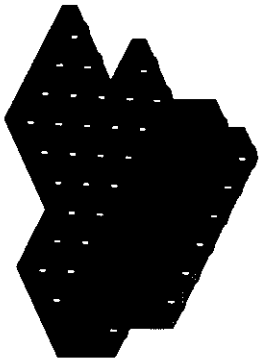
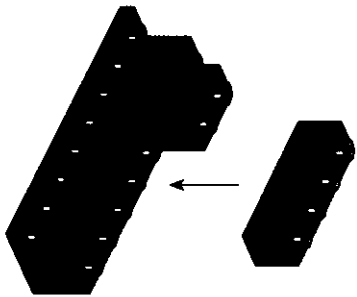

24 January 2007

At its annual investors' meeting held in Kitzbühel, Austria, PALFINGER presented the preliminary results for the financial year 2006. In comparison with the previous year revenues increased by 12.5 percent, and earnings went up by 18.2 percent. 2006 was the second record year in a row.

2 March 2007

In Cherven Brjag, Bulgaria, a new production bay was opened in the presence of Bulgaria's Prime Minister Sergey Stanishev, doubling the capacities of this site.

28 March 2007

The Annual General Meeting resolved to distribute a dividend in the amount of EUR 0.55 per share for the 2006 financial year (EUR 2.20 prior to the stock split). Moreover, the Annual General Meeting approved a 4-for-1 stock split of PALFINGER shares as well as the necessary doubling of the issued share capital from capital reserves.

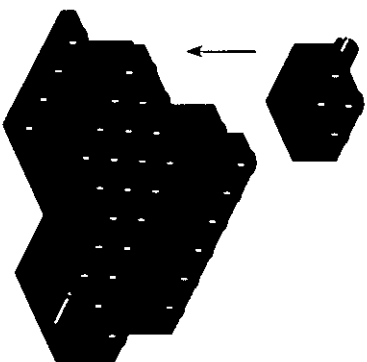

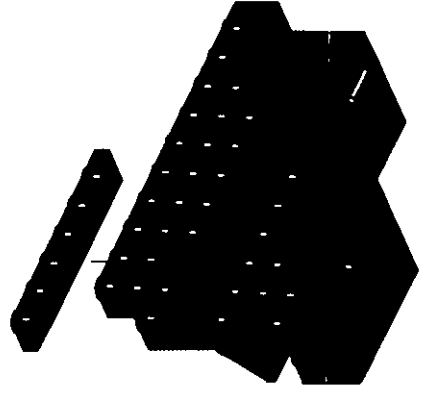
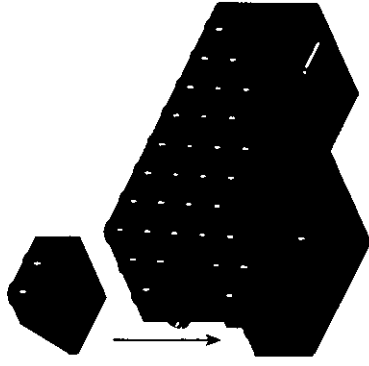
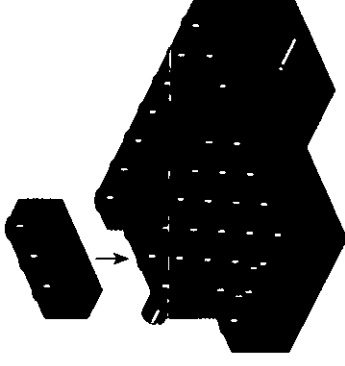

23 April 2007

At the BAUMA trade fair for construction machinery, construction equipment, and construction vehicles held in Munich, Germany, PALFINGER presented its new BISON TA series as well as other new production models. PALFINGER's products were met with great interest by visitors who were able to see them in action.

8 May 2007

The Group's record-breaking growth continued, revenues and earnings once again increased in the first quarter 2007.

25 May 2007

2007 represented a year of celebration, marking the 75th anniversary of the Company's establishment, which was celebrated at a huge gala event where 1,500 guests from all over the world joined in congratulations.

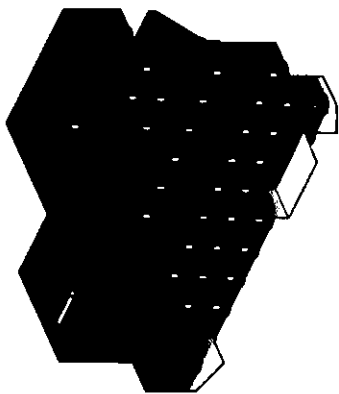

29 June 2007

The 4-for-1 stock split of the PALFINGER shares was implemented as of 29 June 2007, increasing the number of shares from 9,283,750 to 37,135,000. At the same time the price of PALFINGER shares was adjusted to a fourth of the most recently quoted price. Following the split, each shareholder held four shares for each share previously held.

8 August 2007

The results of the first half of the 2007 financial year showed the continued growth of the PALFINGER Group. The first six months were the best in the history of the Company, allowing PALFINGER to further expand its market position.

The Management Board adopted the strategic planning of the PALFINGER Group up to 2011, acting on the assumption of continuing strong growth.

12 September 2007

At the Austrian production site in Lengau the new hexagonal tube production plant was inaugurated. This was a key investment in the ongoing capacity expansion process and also set new standards in terms of quality and process security.

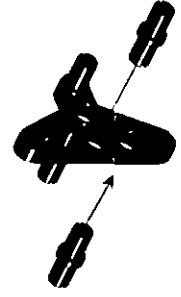
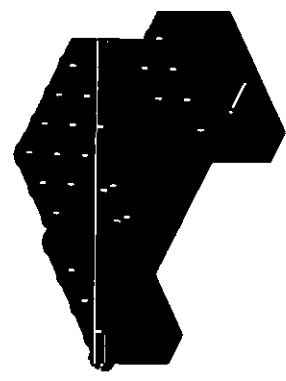
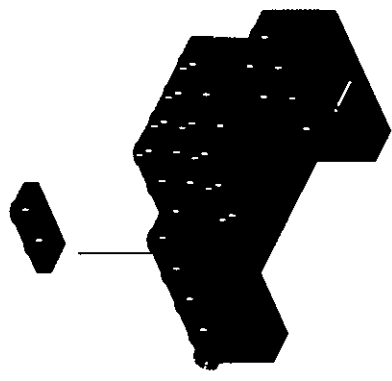
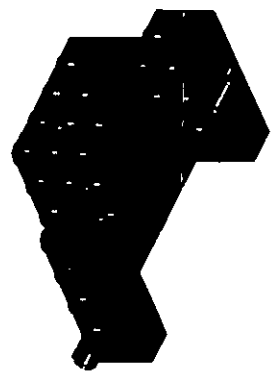

14 September 2007

PALFINGER entered into an agreement on the collective establishment of a distribution joint venture with one of the leading automobile trading companies active in India, Western Auto L.L.C. Dubai, thus laying the foundation for the expected growth in the years to come in this interesting market.

17 September 2007

The Supervisory Board approved changes in the composition of the Management Board. It was decided that, after six successful years with PALFINGER, Eduard Schreiner was to leave the Company after expiry of his contract at the beginning of 2008 and that Wolfgang Anzengruber was to be in charge of the Group's finances, delegating the responsibility for production to the new Management Board member Martin Zehnder.

Furthermore the Supervisory Board approved an extension of the investment programme for the years 2008 to 2010 in order to take into account the continuously growing global market demand.

19 September 2007

PALFINGER took over completely the Croatian supplier PIR metal d.o.o., in which the Company had held a 20 percent stake since 2001, with the intention of converting PIR into a welding and processing plant for structural steel components.

Highlights 2007

24

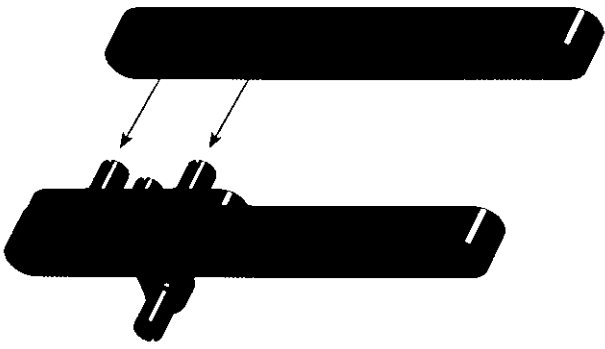

25

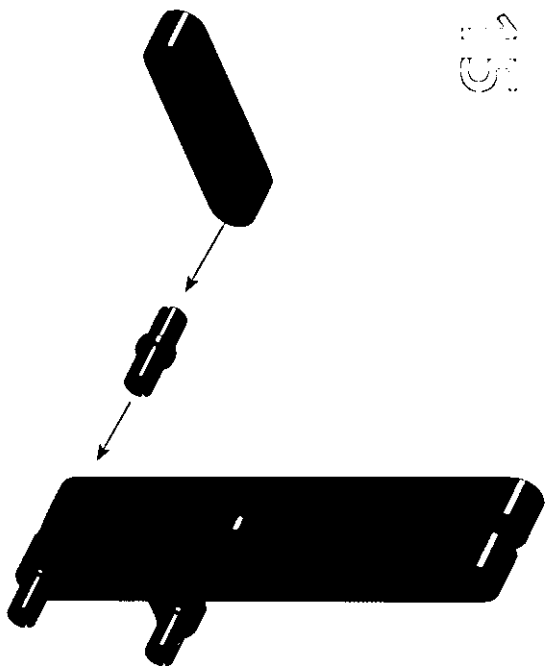

26

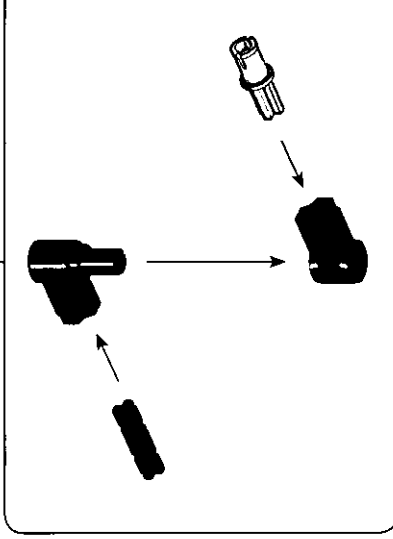

27

24 October 2007

At the international exhibition of building technology SAIE in Bologna, Italy, PALFINGER presented its new *High Performance* crane generation, once again redefining state-of-the-art crane technology. The new crane series was to replace some of the previous crane models and also extend the product range.

29 October 2007

PALFINGER signed an agreement to take over the German company MBB LIFTSYSTEMS AG – one of the major players in the global market for tail lifts. MBB was to complete the product portfolio of the TAIL LIFT division and allow the Company to enter new markets with this product. PALFINGER thus became number two in the tail lift market.

8 November 2007

In the third quarter 2007, the Group once again achieved record results, significant increases in revenues and earnings were expected for the entire year 2007.

88
1

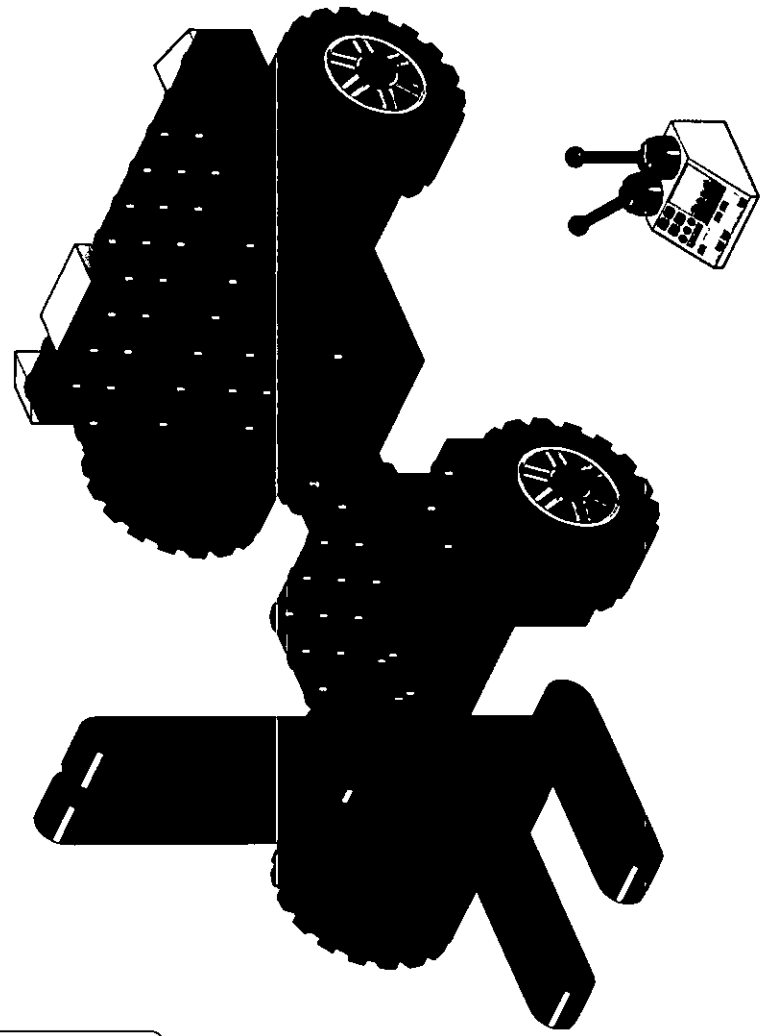
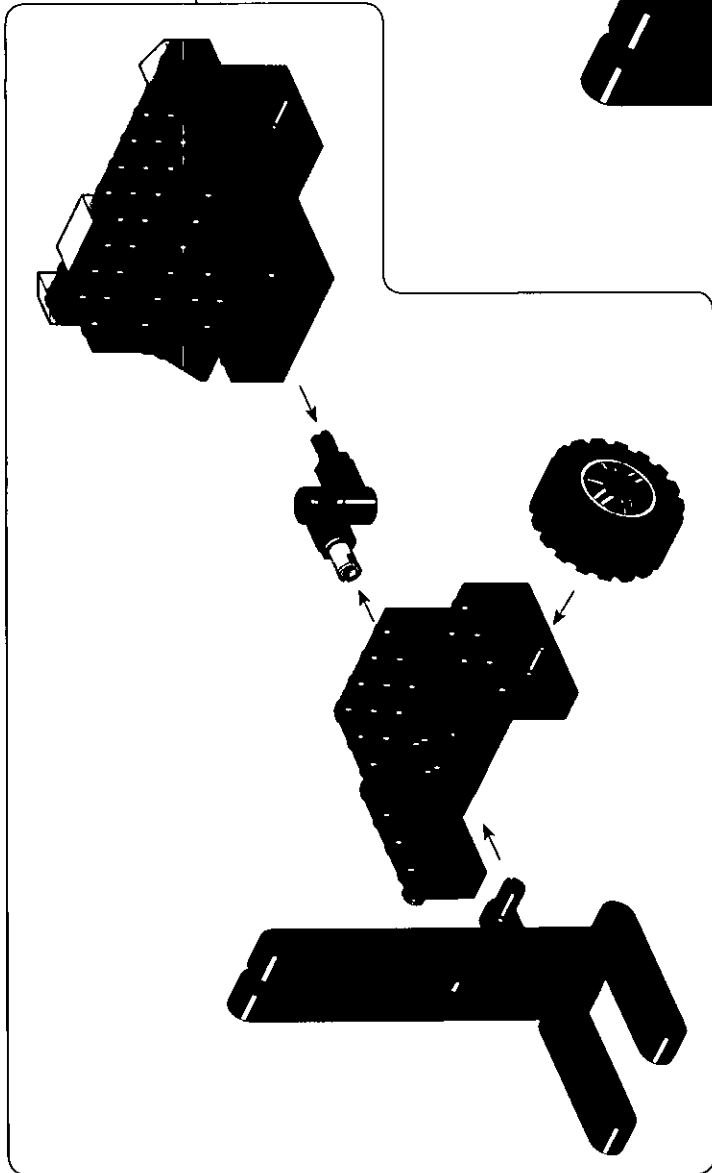

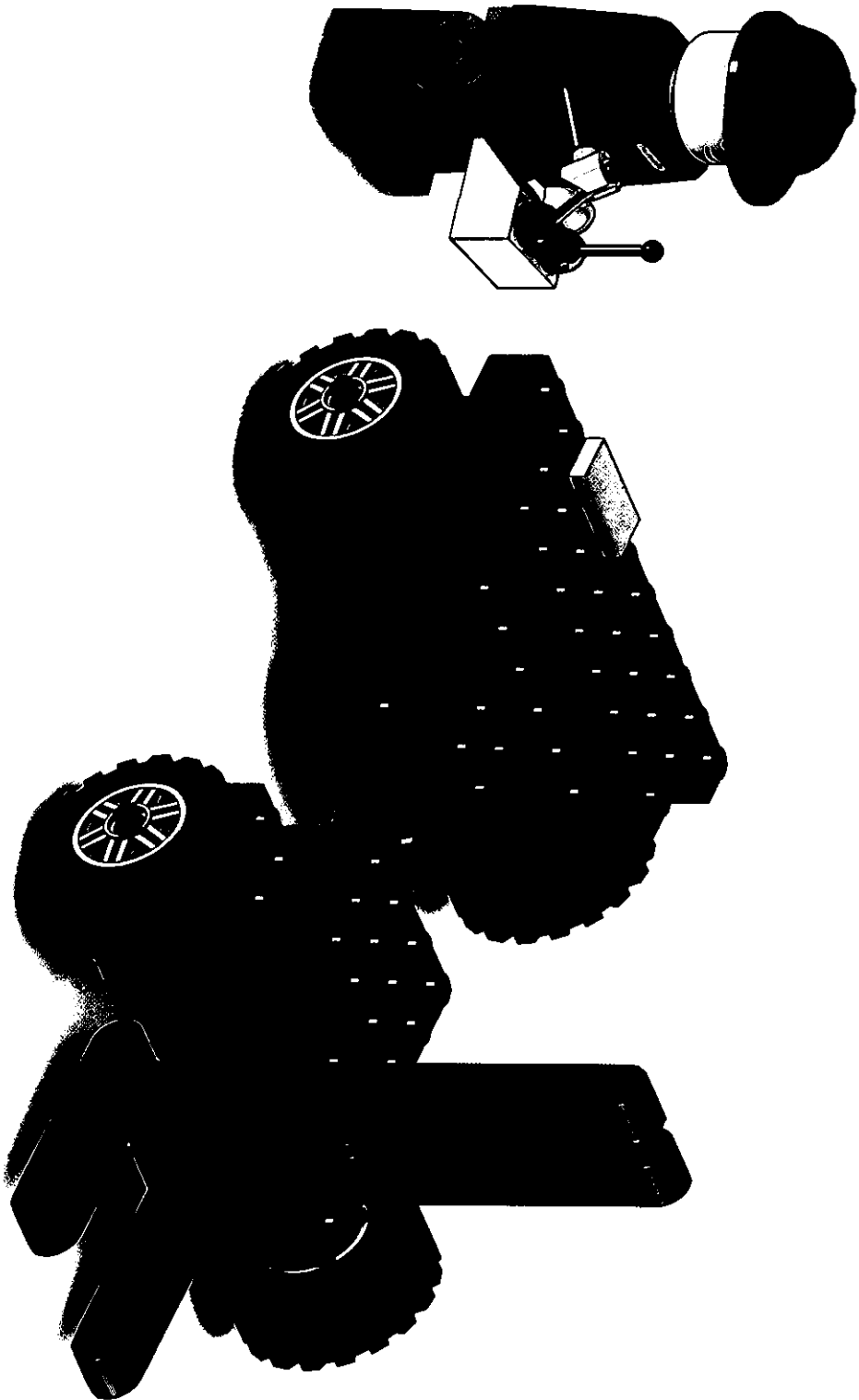

PALFINGER is the global number two in transportable forklifts.

The colourful world of PALFINGER

In 2007 PALFINGER once again achieved record revenues, earnings grew significantly more than expected, and the EBIT margin increased to 14.3 percent. Due to the current investment programme – the largest in the history of the Company – and the acquisition of MBB the gearing ratio went up to 26.7 percent. The equity ratio amounted to 55.8 percent, ROE to 29.1 percent. Return on capital employed remained the same as in the previous year at 25.7 percent.

The PALFINGER Group is headquartered in Bergheim, Salzburg, Austria, and as of 31 December 2007 comprised 30 companies in 17 countries with a total staff of 4,377. The Group operates an optimised global sales and service network with approximately 3,200 outlets and more than 200 independent dealers in more than 127 countries on five continents.

PALFINGER is considered to be the technology leader and number one in the global market for truck-mounted knuckle boom cranes and container handling systems as well as timber and recycling cranes. PALFINGER is the global number two in tail lifts and transportable forklifts. Moreover, the Company is the leading specialist in high-tech railway applications.

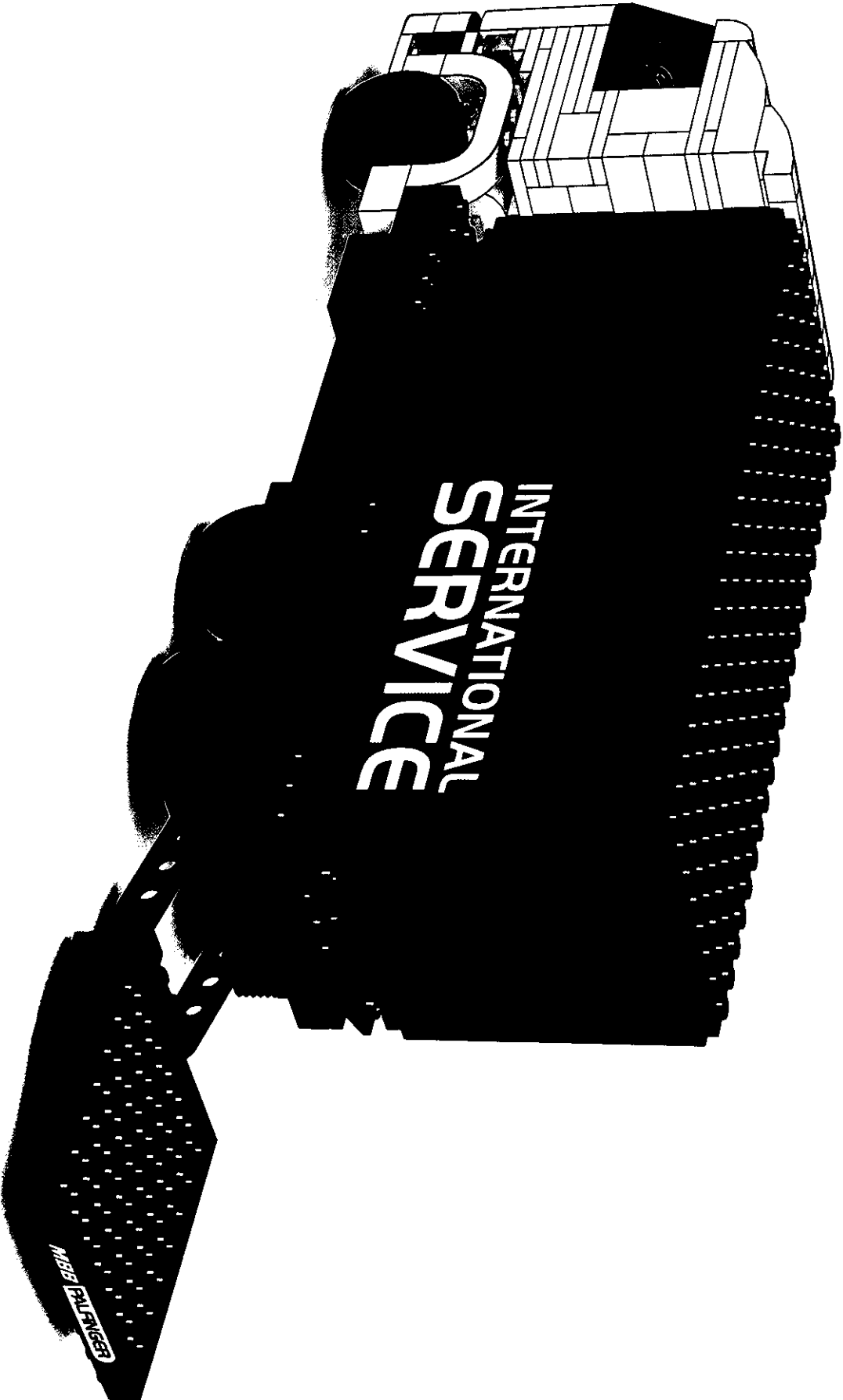

PALFINGER took over the German company MBB LIFTSYSTEMS AG, which made it the global number two in the tail lift market.

Our construction kit still holds great potential for innovation

PALFINGER pursues a strategy of sustainable profitable growth, generated both organically and as a result of acquisitions. By focusing on the three pillars of innovation, internationalisation, and diversification it becomes possible to implement this strategy in a targeted manner. Our employees and their skills and commitment are regarded as the core success factor of the Group. Whenever a strategic decision is taken, PALFINGER takes into account the impact on its staff.

PALFINGER defines innovation not only in terms of the development of new parts and products but also the permanent improvement of processes and organisation. Continuous research is carried out – also in cooperation with universities and other research centres – to develop and/or use new materials and technologies. The introduction of the new *High Performance* crane generation in 2007 was the fruit of the endeavours of preceding years.

In 2004 PALFINGER adopted a new structure. The Global PALFINGER Structure is a matrix, broken down into areas and product divisions with common production processes, thereby ensuring maximum proximity to customers. This structure has since been continuously expanded and adopted to meet changing requirements.

Under the Rapid Process Programme (RAP), which was started in 2001, production processes have been constantly optimised. RAP is aimed at reducing order to delivery times through changing workflow processes. This close scrutiny of the Company's process efficiency has since led to continuous adjustments. The investment programme currently underway is another platform where adjustments are made in the course of the Company's capacity expansion. Programmes such as E², which since starting in 2006 has dealt with special projects with a cost savings potential by increasing efficiency and effectiveness, or World Class Manufacturing – a programme structuring production flows at the individual workplaces – were also created with the objective of being able to respond quickly and efficiently to the needs of the market.

In 2007 PALFINGER focused on further improving the quality of products and processes. The Quality Offensive provides for measures which make it possible to observe delivery times despite strong demand and shortfalls in supplies. Thanks to numerous investments in new manufacturing technologies at the production sites, PALFINGER has created the prerequisites for continuing to meet high standards of quality.

PALFINGER's internationalisation concept follows the motto "Think global, act local".

Internationalisation not only opens up new areas of potential growth for PALFINGER but also reduces dependence on regional economic fluctuations to a minimum, while also optimising production and logistics costs. This includes procurement and assembly of products at the local level and the opening up of new markets. The first step towards achieving this goal was taken as early as 1989, when a trading company was incorporated in Canada, and has been extended to numerous other countries ever since. This process has turned PALFINGER from a family-run business based in Upper Austria into a veritable global player. In the 2007 financial year, PALFINGER stepped up its efforts to lean more heavily on local procurement and assembly, in particular in the US and in Asia. By taking over the Croatian supplier PIR the value creation in this market was enhanced, also allowing the PALFINGER Group to recruit well-trained, skilled staff and obtain access to the Croatian labour market.

Furthermore, the Group managed to broaden the basis in the still emerging Asian market, which is going to become even more interesting for the Group in the years to come. The acquisition of MBB ultimately opened the gates to the tail lift market for PALFINGER even in those countries where the Company has not yet been present with this product.

Diversification ensures PALFINGER's independence from sector-specific fluctuations and guarantees the Company's sales partners an optimised product portfolio. It is specifically applied in areas in which the Group already has a presence. Thus it becomes possible to use cross-selling opportunities existing within the Group. With its numerous product models MBB is going to round out the product portfolio in the TAIL LIFT division from 2008 onwards, thus allowing the Group to produce more closely according to customer specifications.

Diversification optimises the Company's product portfolio for the benefit of PALFINGER's customers and that of PALFINGER.

PALFINGER assumes that the market environment will continue to be strong in the years to come and, on this basis, reckons with continued profitable growth until 2011 at a similar pace as in previous years. The means to achieve that goal are securing as well establishing and/or expanding product divisions and areas of strategic importance. Especially Eastern Europe, Russia, and Asia are those regions where the Company sees good market opportunities which must be seized. The mainstay activities for this purpose will be further capacity increases as well as future projects which were defined and promoted in the reporting year's strategy process.

Just as in the past, the existing product portfolio will be expanded in the years ahead. The medium-term goal for all product groups is a positive earnings contribution as well as a ranking among the top three market players. On the basis of the European market PALFINGER achieved in 2007 the turnaround in its PALIFT division, whose container handling systems have been the leading products in the market for some years. The BISON aerial work platforms division also reached profitability. With the acquisition of MBB the tail lift area too is going to become more profitable and rank among the global top two players. All these successes show how persistently PALFINGER goes about the achievement of its goals.

Growth and value creation are determined by the indicators revenue increase, EBIT margin, and ROCE. In 2007 revenue rose again by 18.9 percent to EUR 695.6 million, the EBIT margin increased by 1.1 percentage points to 14.3 percent. ROCE remained at the previous year's level at 25.7 percent.

Given the excellent business results achieved in previous years and the expected unbroken strong demand PALFINGER is confident that to a great extent it will be able to finance growth from its own resources.

Growth and value creation are promoted both in terms of products and the market

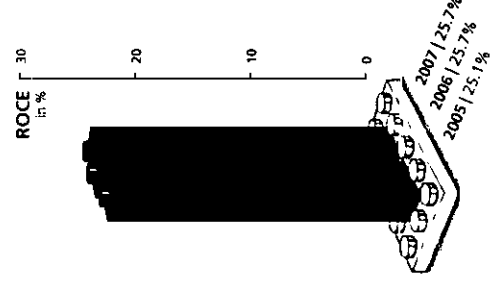

Management and Supervisory Boards/Management Board

The engineers of our success



Wolfgang Anzengruber
CEO

Wolfgang Anzengruber (51), CEO – Chief Executive Officer
Mr. Anzengruber began his career with the Simmering-Graz-Pauker Group. In 1990 he joined ABB, where he most recently was a member of the management team of ABB Austria. In 1999 he joined the management team of Salzburg Stadtwerke, and from 2000 served as Senior Executive Vice President Sales of Salzburg AG. Mr. Anzengruber has been Chief Executive Officer of PALFINGER AG since September 2003. Up to 2007 the enhancement of the value-added process fell under his responsibilities. He then delegated responsibility for production to the new COO and instead has taken over responsibility for the Group's finances. Moreover, Mr. Anzengruber is in charge of legal affairs, IT, personnel, procurement, communications, and investor relations.



Eduard Schreiner
CFO

Eduard Schreiner (42), CFO – Chief Financial Officer (up to 31 December 2007)
Mr. Schreiner worked at BDO (now Deloitte) until 1993. He then joined OMV AG, where he was appointed Managing Director of OMV Tschechien GmbH in 1998. Mr. Schreiner was appointed Chief Financial Officer of PALFINGER in March 2002.



Wolfgang Pilz
CMO

Wolfgang Pilz (48), CMO – Chief Marketing Officer
Mr. Pilz has over 22 years of experience in the crane business at PALFINGER. He was appointed Marketing & Sales Manager of the truck cranes division in 1997. Since 2003 he has been Chief Marketing Officer for the core business areas of truck-mounted cranes and container handling systems.



Herbert Ortner
CMO

Herbert Ortner (39), CMO – Chief Marketing Officer
Mr. Ortner was global Business Unit Manager for industrial hoses at the public listed Semperit Group until 2001. He then joined PALFINGER, where he developed the spare parts, equipment, and service business before being appointed Chief Marketing Officer in 2003. The focus of his activities includes railway applications, tail lifts, transportable forklifts, and aerial work platforms, as well as the further expansion of the service business.



Martin Zehnder
COO

Martin Zehnder (40), COO – Chief Operating Officer (since 1 January 2008)
Mr. Zehnder started his career at Alstom Schienenfahrzeuge AG in 1984. From 2000 to 2005 he was Managing Director of Development and Production for Keystone Europe in France. In 2005 Martin Zehnder became Global Manufacturing Manager in charge of all manufacturing facilities of the PALFINGER Group and since January 2008 has been responsible for global production as the Company's Chief Operating Officer.

Alexander Exner (60), Chairman of the Supervisory Board

Mr. Exner is a management consultant and founding member of the Neuwaldegg consultancy group. His relationship with PALFINGER goes back over 25 years. Mr. Exner was CEO of Palfinger Holding AG in the 1990s. After the establishment of PALFINGER AG, he became Deputy Chairman of the Supervisory Board and has been the Chairman of the Supervisory Board since the end of 2003.



Alexander Exner
Chairman of the Supervisory Board

Hubert Palfinger (65), Deputy Chairman of the Supervisory Board

Mr. Palfinger began with the industrial production of truck-mounted cranes in 1964 at the age of 22, after taking over his father's business. The majority shareholder of the Group headed the Company for 33 years and was Chairman of the Supervisory Board from 1997 to 2003.



Hubert Palfinger
Deputy Chairman of the Supervisory Board

Hubert Palfinger jun.
Kurt Stiassny
Peter R. Scharler
Alexander Doujak

Delegated by the Works Council:
Johann Mair
Gerhard Gruber
Alois Weiss

Foreword by the CEO

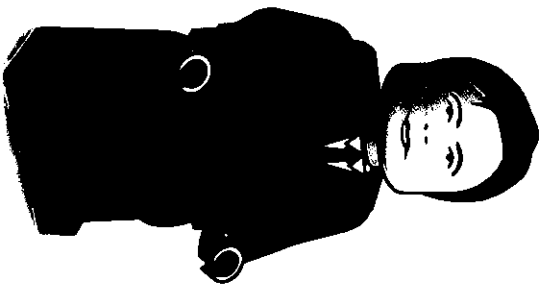

Dear shareholders,

The 2007 financial year has been highly gratifying for the PALFINGER Group. Not only did we celebrate the Company's 75th anniversary but once again we saw strong growth rates, thus laying a sound foundation for the future. On the one hand, market growth was a continuing trend throughout the year, while on the other we managed to utilise potentials and expand our international market position even further, thus creating a foundation for the years to come.

This Annual Report documents the outstanding evolution of our results. The Group's revenue rose by approximately 19 percent, and earnings significantly more than expected by 30 percent. What is particularly satisfying in this regard is that in 2007 we managed to achieve the turnaround also in the HYDRAULIC SYSTEMS segment with product divisions that are in part still very small. The persistent efforts taken in previous years have thus clearly paid off, creating a sound foundation for the next steps towards expanding our business.

A big challenge the Company faced was the implementation of the investment programme, commenced in 2006, with the objective of helping us cope better with market growth. Expanding capacities with production in full swing was a complex task which we were able to handle not least thanks to the enormous commitment and flexibility of our staff.

At the same time we were called upon to ensure an adequate supply of resources. We continued to see shortfalls in raw materials, while prices rose, sometimes quite sharply. In order to be able to maintain and/or improve the high quality of PALFINGER products even in such an environment, we initiated our Quality Offensive, which has become an integral component at all plants of PALFINGER and our suppliers.

Furthermore, with the launch of new product lines we succeeded in retaining our position of technology leadership in 2007 as well. We take particular pride in the new *High Performance* crane series, reflecting our research and development work carried out in previous years.

There is no doubt that the strongest asset we have is our personnel, which is why we have expanded programmes for the promotion and motivation of our staff and also created fresh initiatives to attract new employees.

At this point I would like to acknowledge the dedication of the Supervisory Board and the staff representatives and thank them for their cooperation and contribution towards the Company's successful development. On behalf of the entire Management Board I would like to extend my warm thanks to all our staff for their high level of commitment and considerable efforts, as well as to our shareholders and stakeholders for putting their trust in PALFINGER.



Wolfgang Anzengruber

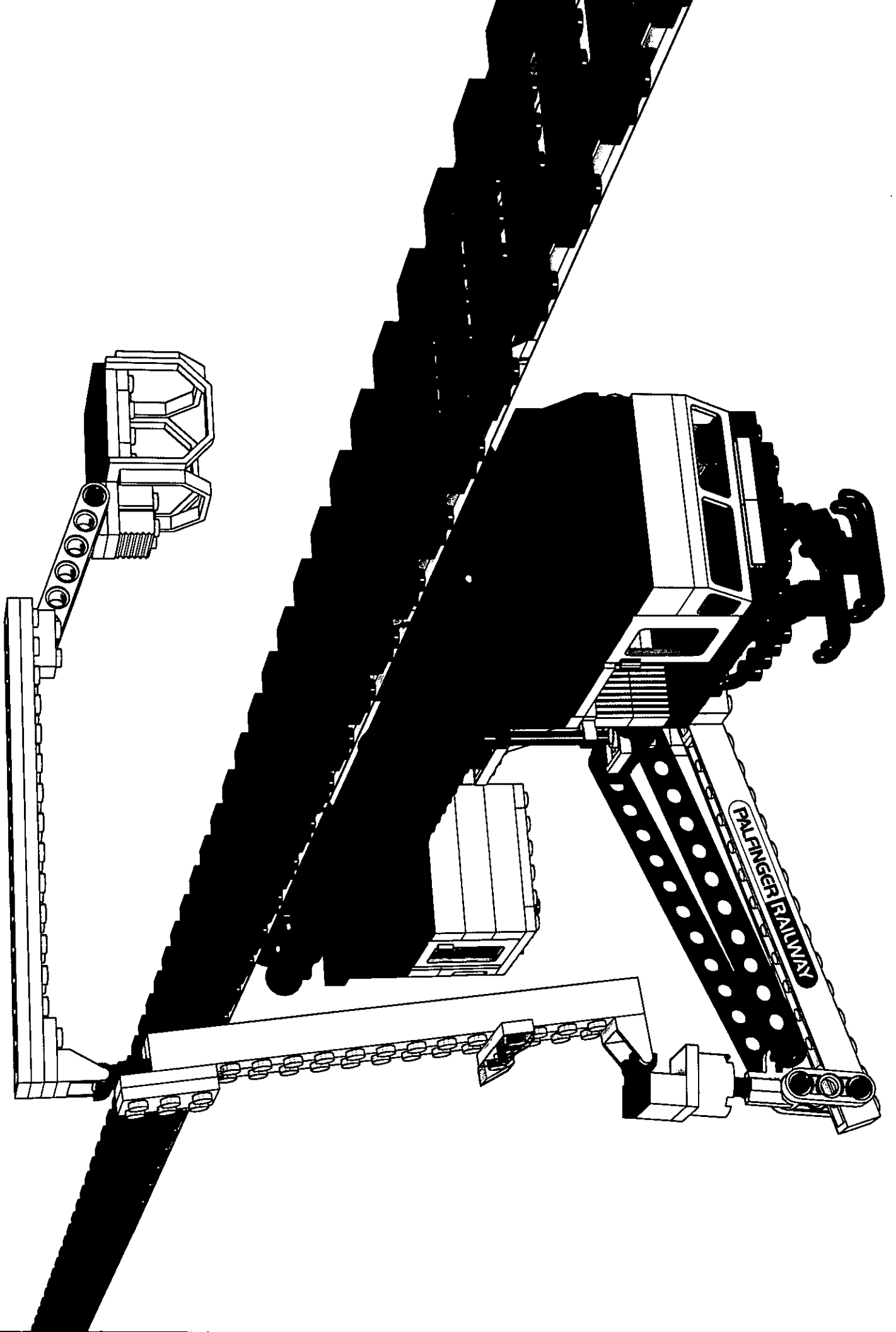

Consolidated Management Report

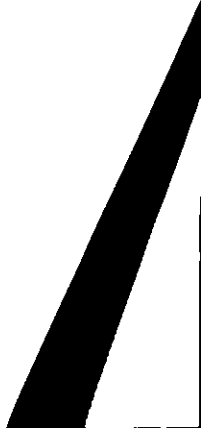

The world we play in

Economic Background

The global economy was highly dynamic in 2007, growing by around 4.9 percent. The period under review was marked by the continued depreciation of the US dollar, rising crude oil prices, and, starting from the third quarter, the US real estate crisis and turbulence in the financial markets linked to US subprime mortgages. Despite all this, economic growth was only slightly below the original estimates, which was mainly due to the strong performance of the emerging markets. Nevertheless, this development caused the International Monetary Fund (IMF) to change its annual growth forecast for 2008 to 4.1 percent in January 2008.

In spite of turbulence during the second half of the year, the eurozone continued to be robust, with the impact of the credit market crisis remaining limited. The economic growth rate for the entire year 2007 amounted to 2.6 percent, which is slightly lower than the figure of 2.8 percent in the previous year. However, as the framework conditions have deteriorated, the prospects for 2008 have become clouded.

The countries in Central and Eastern Europe continued to be characterised by strong growth and a rapid expansion of the financial sector due to the emergence of new groups of customers. As economic growth remained strong at 5.5 percent in 2007 it is likely that the current investment cycle has reached its peak in most of these countries. Economic forecasts for 2008 predict a rate of around 4.6 percent.

Economic development in Asia remained marked by high growth rates in China and India. China again reported double-digit growth rates of 11.4 percent. In order to prevent an overheating, the People's Bank of China raised interest rates on debt and the minimum reserve requirements of the banks, but the boom continued. With an inflation rate of more than 6 percent no marked easing is in sight.

The economic situation in the US was surprisingly robust in 2007, even though the construction and transport industries suffered from the consequences of the real estate crisis. Growth only lost significant momentum in the fourth quarter due to the correction in the housing market, rising energy prices, and the more restrictive lending policy. In 2007 the gross domestic product rose by 2.2 percent as compared to 2.9 percent in the previous year.

Latin America also reported positive economic development. The Brazilian economy grew by 4.7 percent in 2007, the most important impetus being domestic demand. In the following year, the country's economic performance is expected to slow down slightly given the difficult situation of the global economy.

The US dollar depreciated considerably against the euro. At the end of the period under review the exchange rate was 1.47 as compared to 1.32 at the beginning of 2007. The Chinese yuan appreciated against the US dollar, but

Starting from the third quarter, the 2007 financial year was affected by developments in the US. However, PALFINGER's future markets continued to show strong growth.

depreciated against the euro to EUR 10.75 of late. Although the Canadian dollar was temporarily strong, its exchange rate to the euro was 1.45 at the end of the year. The Brazilian real rose to EUR 2.61.

The existing trends in the markets for raw materials were reinforced in 2007, prices rose significantly. The low level of inventories and the increasing demand, inter alia from the emerging economies in China and India, led to new record highs in oil prices. As of the end of the period under review the Brent crude oil price had increased to USD 95.72 per barrel. Should the expected correction not take place in 2008 impacts on the economic cycle are to be expected, in particular in the eurozone.

Industry Review

PALFINGER's products address various industries whose performance is also reflected in the business development of the Group's individual product divisions. The industrial sectors with the strongest influence on the sales potential of PALFINGER's products are construction and transport. In addition, PALFINGER products are primarily used in the recycling industry, agriculture and forestry, commerce, and by local authorities.

Construction Industry

After 2006 being a very strong year for the construction industry, the individual regions in Europe developed differently in 2007. In Western Europe growth halved as compared to the previous year, coming down to around 1.7 percent, and EUROCONSTRUCT expects a further decline to around 1 percent for 2008. This downturn was caused by the turbulence in the international financial markets, which led to a higher level of caution regarding investments, the strong euro, high interest rates, and the general drop in demand. A clear reduction in investments in construction was witnessed in particular in Spain, Ireland, and Great Britain, caused by the flagging real estate markets and the resulting excess capacities.

In contrast, dynamics were on the rise in Central and Eastern Europe, turning the CEE countries into the driving force for the construction industry. In 2007 a growth rate of 7.6 percent was achieved, a further increase is expected for 2008. The most outstanding growth rate, a double-digit figure, was achieved in Poland. While residential construction is on the decline, civil engineering is more and more becoming the main impetus of growth, in particular in Eastern European countries, as a consequence of the subsidies granted by the European Union.

In the US the construction industry showed divergent developments. While according to the US Census Bureau residential construction suffered negative growth running into double figures, the other sectors of the construction industry continued to report double-digit growth, which was, however, not sufficient to prevent a shrinkage of the entire construction industry. After an expansion of construction volumes by a total of 23 percent in 2004 and 2005, largely due to the residential building sector, the trend reversal was first noticed in 2006 when a growth rate of only 5.3 percent was achieved. In 2007 the crisis in the field of residential construction became an important issue for the overall economy in the US.

The two most important sectors, construction and transport showed only slight growth rates in Western Europe, while developments in Eastern Europe and Asia were highly dynamic.

Market Review

In Asia, in particular in China, India, Indonesia, the Philippines, Thailand, and Vietnam, construction industry growth rates remained high. The solid economic growth gave rise to a comprehensive infrastructure expansion, in particular in China and India.

Transport and Haulage

Road transport, which along with the increase in economic growth also shows an upward tendency, accounts for the highest share in overall freight transport in Europe. While this share continues to grow, attempts to reduce the negative consequences of truck traffic are being made. In 2006 the European Union introduced a new emissions standard for all commercial vehicles registered after 1 October 2006.

This entailed a sharp increase in the number of new registrations in the months prior to the introduction of the standard followed by a short-term significant decline. According to the European Automobile Manufacturers' Association (ACEA), the number of newly registered trucks over 3.5 tonnes in the EU-15 countries rose only by around 1 percent in 2007 as compared to the previous year. In contrast, a clear increase could be witnessed in the new member states of the European Union, where the number of new registrations of trucks over 3.5 tonnes rose by around 39 percent and of heavy-duty trucks over 16 tonnes by more than 47 percent as compared to the previous year. What stands out are the higher-than-average growth rates of 55 and 69 percent, respectively, that were reported in Poland.

With around 100,000 new registrations of trucks over 3.5 tonnes per year Germany is the biggest market for trucks in Europe, followed by France, Great Britain, and Spain with around 50,000 registrations each. France and Great Britain reported a decline in 2007 while Germany and Spain recorded a rise of 6 and 10 percent, respectively, in new truck registrations as compared to 2006.

In the US following a downward movement in the transport industry in 2006, an upswing was recorded in 2007. The Freight Transportation Services Index rose by slightly more than 1 percent, however still remaining lower than in 2005.

China and India have been investing heavily in the expansion of the transport sector for years, which can hardly keep up with the enormous economic growth. In the years to come not only further expansion but also the management of infrastructure will be of increasing relevance.

Competitive Environment

The main product distributed by PALFINGER is the truck-mounted knuckle boom crane, which accounts for 60 percent of the total revenue generated by the Group. With a market share of around 35 percent PALFINGER is the global leader in truck-mounted knuckle boom cranes, followed by HIAB, a division of the Cargotec Group, and the unlisted Italian crane producer Fassi. Most of the other competitors are either significantly smaller than PALFINGER or offer these products only outside their core business areas and/or with comparatively low contributions to revenues.

The American market is also dominated by the above European suppliers so that the consequences of the weak US dollar do not put PALFINGER at a disadvantage as compared to its competitors in the market.

The market for truck-mounted cranes has grown continuously in recent years and the upward trend is expected to continue. This makes it possible for the manufacturers to achieve growth without having to gain additional market shares, which prevents the crowding out of competition.

PALFINGER distinguishes itself from its competitors not only due to the size of the Group and its cost structure but primarily also due to its know-how about technology and materials and its global dealer and service network, which renders any direct comparison impossible. New suppliers would not be able to compete, either in terms of costs or service quality, with the optimised workflows and a mature network, which makes it significantly harder for new competitors to enter the market.

Customers and Suppliers

Customer and Dealer Network

PALFINGER products are sold in 127 countries all over the world. The global distribution and service network with more than 200 independent dealers and more than 3,200 service centres is a major contribution to the quality approach and therefore also to the success of the Group.

In 2007 this network became denser, in particular in the US. With the acquisition of MBB towards the end of the year, the number of PALFINGER outlets once again rose by around 400.

PALFINGER organises annual supplier conferences with the aim of promoting the cross-border exchange of experience and information. International conferences for dealers from all over the world in Austria, and area dealer conferences at locations within the respective PALFINGER areas are organised in turn. In 2007 the distribution partners from the Europe sales area exchanged information and opinions at Fuschl am See, Austria, while those from the North America sales area met at Niagara Falls, Canada, those from the South America sales area in Lima, Peru, and those from the Asia & Pacific sales area in Singapore.

Market Review

At PALFINGER awareness of the wishes of its business partners forms the basis for all decisions regarding target-oriented future activities. Surveys regarding all product divisions were carried out among end customers in the areas Europe and North and South America. The level of satisfaction among all dealers and suppliers was surveyed as well. Numerous potential areas for improvement and specific measures could be derived from the findings of these surveys. At the moment, special catalogues of measures are being developed in cooperation with the dealers on the basis of the results of the end customer surveys and in cooperation with the internal departments on the basis of the results of the dealer and supplier surveys. These measures will then be implemented in the course of several projects in the months to come and feedback will be given to the respondents.

Purchasing

As demand for PALFINGER products remained strong without interruption in 2007, PALFINGER was once again faced with the challenge of ensuring the timely supply of sufficient quantities to the manufacturing and assembly plants. This still proved difficult in the area of raw materials, in particular steel plates. PALFINGER was confronted with a further increase in prices in this sector, with prices stabilising at a very high level only towards the end of the year.

In the course of its capacity expansion efforts, PALFINGER was forced to eliminate bottlenecks in its own production capacities, which were caused by a temporary decline in flexibility, by availing itself of external capacities.

The comprehensive initiatives aimed at an increase in delivery capacities of subcontractors showed positive effects in the period under review. Measures were taken to select and train suitable additional suppliers on the one hand. On the other, comprehensive support was given to the existing strategic suppliers, assisting them in expanding their capacities, in particular in connection with the new *High Performance* crane series to be introduced.

At a suppliers' meeting hosted by PALFINGER in 2007 the strategy of PALFINGER was discussed with around 170 representatives of suppliers in order to include them more in further developments. The internal Global Cost Initiative of PALFINGER was expanded to include selected suppliers. In this context, PALFINGER has been analysing the processes used by the suppliers in order to support them in achieving production optimisation.

Quality Offensive

The entire year 2007 was characterised by the Quality Offensive, which was launched in the second quarter 2006. The declared aim was to optimise the existing quality assurance processes and to develop new systems to increase the quality of production and procurement processes. The campaign is to ensure that PALFINGER, while expanding its capacities, still meets its high quality standards and that customer satisfaction is guaranteed.

In 2007 one of the main focuses of the Quality Offensive was the cylinder production. In this field, measures to improve processes and to further increase component cleanliness were implemented both at the PALFINGER plant in Tenevo and at the respective suppliers.

PALFINGER also designated quality assurance staff who supported the implementation of PALFINGER's quality standards. Further improvements of quality are to be achieved in the medium term by a consistent acceptance process from suppliers with audits and production part approval.

Quality assurance agreements are a vital element of the cooperation with suppliers of PALFINGER. At the moment such agreements have been entered into with around 130 suppliers. In 2007 existing agreements were updated to provide for shorter order to deliver times, and new suppliers joined the programme. With these agreements, PALFINGER strives for increased process reliability and consequently also a sustainable reduction in quality-related costs.

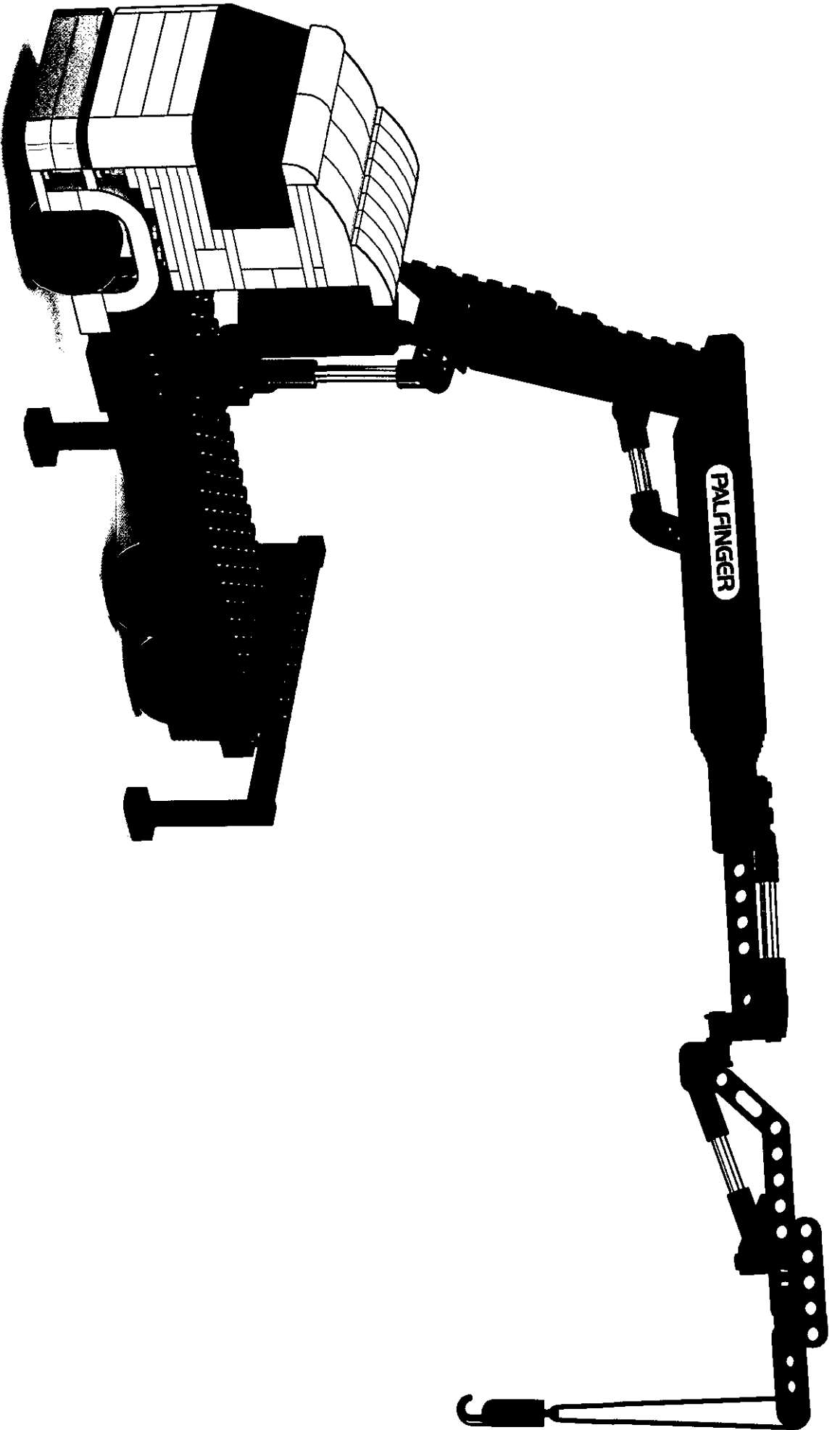

PALFINGER is the technology and innovation leader and the number one in the global market for knuckle boom cranes.

If building blocks are fitted together smoothly, even the most ambitious goals can be reached

Business Development in 2007

PALFINGER successfully continued to pursue its profitable growth strategy during the 2007 financial year. As in recent years, the Group reported an additional significant surge both in revenues and earnings. This development was supported by the positive economic environment, in particular in Europe. The continued strong demand for all systems, in particular in the cranes segment, which resulted in a high order intake, emphasised PALFINGER's potential for growth in the market for lifting, loading, and handling solutions and led to new record levels of orders in hand.

Revenue rose to EUR 695.6 million, which is 18.9 percent above the figure of EUR 585.2 million for the same period of the previous year. EBIT increased by 29.4 percent to EUR 99.6 million, up from EUR 77.0 million in 2006. The EBIT margin amounted to 14.3 percent as compared to 13.2 percent in the previous year, reaching the highest level ever achieved in the history of the Company. ROCE was 25.7 percent, highlighting the profitability of PALFINGER.

The foundation for this sustainable profitable growth was the lucrative crane business of PALFINGER in Europe. The main markets of PALFINGER in Western Europe remained strong and the trend towards higher performance classes and fitting variants, triggered by the increase in fields of applications of PALFINGER technology, continued in 2007. In addition, PALFINGER was extraordinarily successful in capitalising on the developments in its promising markets in Eastern Europe, in particular Russia, as well as Central and South America.

The knuckle boom crane business in North America was affected both by the real estate and financial crises and by the weakness of the US dollar against the euro and also against the Canadian dollar. In this area PALFINGER is strongly promoting new fields of application, in particular for large cranes. In the telescopic crane business in South America, the cooperation with SENNEBOGEN was pushed. EPSILON also succeeded in further pursuing its growth strategy.

True to the motto "We make our customers more successful!" the service area is gaining more and more importance. Service, besides technology and quality, has become a vital factor for a company's differentiation from its competitors. PALFINGER guarantees service availability with the help of local partners included in its intensive service network. With an increase in product population and a service-oriented approach, revenues and earnings in this sector were once again improved.

PALIFT container handling systems reported a considerable rise in productivity, primarily during the second half of the year. In the Asia & Pacific area, primarily in China, investments were made in this promising division. BISON aerial work platforms achieved a turnaround thanks to the initiation of product development measures and the

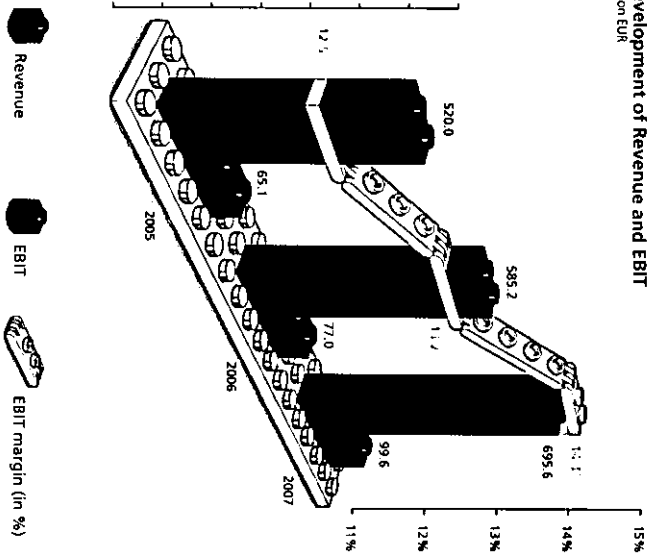

Performance of PALFINGER

Localisation of assembly activities and in 2008 will also profit from the start of serial production of the new product series. The TALL LIFT division was marked by the acquisition of MBB, an important strategic step taken towards the end of 2007. The PALGATE Continental European tail lift will merge into MBB in 2008. In the former tail lift product division, RATCLIFF succeeded in maintaining its market shares in spite of a difficult economic environment. In the CRAYLER product division European and North American markets performed differently. PALFINGER succeeded in increasing market penetration in the European market, primarily in Germany, so that the CRAYLER division contributed to the Group's positive results, whereas the investments in the slumping US market must be seen as investments in the reconstruction of a foundation for the future. The RAILWAY division profited from the outstanding project situation during the year and from newly introduced system solutions.

TEUR	Q1 2007	Q2 2007	Q3 2007	Q4 2007
Revenue	162,396	178,196	164,016	191,015
EBIT	23,969	27,024	22,355	26,290
EBIT margin	14.8%	15.2%	13.6%	13.8%

In spite of the investment programme, which is being implemented in stages, and new human resources development approaches, enormous demand during the period under review resulted in a continued scarcity of capacities and a tight materials supply situation. This led to longer delivery times and delayed the impact of passing on increased raw material prices on the market. In order to cushion against longer delivery times dealers partly started to place advance orders which further increased PALFINGER's order intake during the period under review.

Although measures such as the deployment of additional suppliers started to become effective during the year, bottlenecks in material and component supply still occurred. In this context, PALFINGER not only faced increases in material prices, but also higher contract-awarding costs in order to work to capacity. These increases, amongst other things, were caused by a lack of flexibility in cases of machine failures and delays in putting machines into operation in the course of the expansion measures. The increase in personnel capacities required for capacity expansion posed another growing challenge. Skilled labour was scarce at nearly all European sites and in particular new member states of the European Union, like Bulgaria and Slovenia, were affected by an increase in staff mobility.

In 2006 PALFINGER started the largest investment programme in the history of the Company, which provides for investments in capacity expansion and in the further improvement of efficiency and quality in the total amount of around EUR 80 million by the end of 2008. A subsequent second extension programme for the years 2008 to 2010 was approved in autumn 2007 in order to take into account the continuously growing global market demand and to shorten delivery times drastically in the future. By the end of the year 2007 the first measures were reflected in a capacity increase of 10 to 15 percent as compared to the same period in 2006.

Significant Changes

Sustainable Profitable Growth Strategy Implemented

In August the Management Board adopted the strategic planning activities of the PALFINGER Group for the period up to the year 2011. As PALFINGER assumes that the continuous double-digit growth, facilitated by both organic growth and acquisitions, will be uninterrupted in the years to come, the Company intends to expand its global presence in the non-European areas even more and to continue to consistently make use of the opportunities in the Eastern European markets. Investments in existing staff and the development of additional human resources are central factors of success in implementing this strategy. The capacity expansion measures agreed upon will be accompanied by lean initiatives across all corporate divisions in order to guarantee the highest possible level of efficiency and flexibility.

Organisational Adjustments for the Implementation of the Strategy

In order to be able to meet the increased demands on the basis of the PALFINGER value-creation strategy and handle the increase in capacities in the best possible manner, the Supervisory Board, at its September meeting, resolved to create a separate Management Board function for the production process. Martin Zehnder was appointed to the Management Board as the designated COO. On 1 January 2008 he took over responsibilities for the entire production area from Wolfgang Anzengruber. All responsibilities of the finance department are now entrusted to the Chairman of the Management Board so that an optimal combination of strategy and performance in terms of revenues and earnings is guaranteed.

As practice during recent years has shown, smaller organisational units, with the responsibility for processes being split, were not managed as effectively as necessary. For this reason the production areas EPSILON, TAIL LIFT, and RAILWAY have been listed as "independent units" within the matrix organisation of PALFINGER since January 2008. That means that they are now organised according to the principle of uniform management and, as far as possible, are free to decide to what extent they will use the matrix units of the PALFINGER structure.

Acquisitions Boost the Group's Competitive Position

The 100 percent take-over of MBB LIFTSYSTEMS AG, one of the world's leading suppliers of tail lifts, was concluded in December. The company is based near Bremen, Germany, and has distribution subsidiaries in Great Britain, France, Belgium, the Slovak Republic, and the US. MBB looks back on decades of experience in the development, production, and distribution of tail lifts and offers a comprehensive range of technically mature products that are well established in the market. In the 2007 financial year MBB generated revenues of around EUR 61 million, employing a staff of 260. This was another material building block towards achieving the strategic objective of PALFINGER to become the global number one in the tail lift area.

In September a distribution joint venture agreement was entered into with one of the leading automobile trading companies in India, Western Auto L.L.C. Dubai. PALFINGER will hold an interest of 26 percent in the jointly owned

Performance of PALFINGER

company. This investment served the purpose of creating, at an early point in time, a foundation for successfully positioning PALFINGER in this dynamic growth market.

The complete take-over of the Croatian supplier PIR metal d.o.o., in which PALFINGER used to hold a 20 percent stake, was carried out successfully in September. This acquisition will contribute to further optimising the value-creation chain in the area of production.

Learning as a Factor for Making the Strategy Implementation a Success

PALFINGER takes the aspects of everyday learning and networking of knowledge into account by means of numerous personal contacts and targeted cross-border exchanges of communication. In addition to the area dealer meetings and the service meetings, a suppliers' meeting was organised in Austria in 2007, which was attended by around 170 representatives of international suppliers. The strategies and standards for all stages of the value-creation chain have been concentrated consistently. The Quality Offensive launched in 2006 is still given a great level of attention internationally. The newly structured, bundled resources in the production area, under the direction of the newly appointed Management Board, are to promote the further development of PALFINGER and its partners.

Investments in Capacity, Rationalisation, and Quality

Numerous measures under the ongoing investment programme were implemented and/or completed in 2007. At the Austrian production site in Lengau, the new automated hexagonal tube production plant started operations, which will not only contribute to a further improvement of quality but also increase efficiency and capacities in the production process.

In Cherven Briag, Bulgaria, the enlargement of the factory workshop in order to double production capacities was completed, further measures for the optimisation of the location are still being taken. The production of special cylinders was relocated from Lengau to Tenevo, Bulgaria, where the additional plant expansion for a significant increase in cylinder capacity is in full swing. In Maribor, Slovenia, layout adjustments were performed and the large component centre started operations. The new PIR production site in Delnice, Croatia, will further contribute to the optimisation of the production flow.

At the assembly location for aerial work platforms at Löbau, Germany, the real estate and buildings finally became the Group's property, a new paint shop was built and the factory workshop was expanded.

At Niagara Falls, Canada, crane assembly activities were concentrated and spare parts supply was bundled in the new building, and in Caxias do Sul, Brazil, the course was set to increase output in the years to come. In Shenzhen, China, preparations were made for local manufacturing and assembly of hook loaders to lower production costs.

The continuation of the investment programme will result in a further increase in capacities by the end of 2009 of around 10 to 15 percent as compared to the end of 2007.

Putting building blocks together differently opens up better opportunities

Legal Changes in the Group Structure of PALFINGER

The Annual General Meeting of 28 March 2007 resolved on a 4-for-1 stock split as well as the necessary doubling of the issued share capital from capital reserves to TEUR 37,135.

By means of the Merger Agreement of 14 May 2007, Palfinger Industrieanlagen GmbH was merged into PALFINGER AG as the absorbing company with retroactive effect as of 31 December 2006 for the sake of simplifying internal structures. Palfinger Consult AG was compensated for its 5 percent minority interest in Palfinger Industrieanlagen GmbH by being granted shares of PALFINGER AG of corresponding value.

As per 19 September 2007 the take-over of the remaining 80 percent of the Croatian supplier PiR metal d.o.o. was finalised. The PALFINGER Group had held an interest of 20 percent in PiR metal d.o.o. since 2001. At the time of take-over the steel component manufacturer employed a staff of 95.

In December 2007 the winding up of Regio Cargo Transporttechnik GmbH i.L., Zorneding-Pöding, Germany, was completed and the company was deleted from the Register of Companies.

The 100 percent take-over of MBB LIFTSYSTEMS AG, Ganderkesee, Germany, and its five subsidiaries by Palfinger Europe GmbH was concluded as per 6 December 2007.

Information According to Sec. 243a of the Austrian Business Code (UGB)

Sec. 243a (1) UGB

As of 31 December 2007 the issued share capital of PALFINGER AG was EUR 37.1 million (previous year: EUR 18.6 million), divided into 37,135,000 (previous year: 9,283,750) no-par-value bearer shares. The increase in the number of no-par-value shares was caused by the 4-for-1 stock split performed on 29 June 2007.

Each PALFINGER share entitles its holder to one vote.

As of 31 December 2007 PALFINGER AG held 1,805,000 own shares (previous year: 1,845,644, before split: 461,411).



A 4-for-1 stock split was performed in 2007.

Performance of PALFINGER

Sec. 243a (2) UGB

PALFINGER AG is not aware of any restrictions regarding the voting rights of the PALFINGER shares and their transferability, including restrictions agreed upon between shareholders.

Sec. 243a (3) UGB

As of 31 December 2007 the Palfinger family directly or indirectly held more than 60 percent of the shares in PALFINGER AG.

Around 33 percent of the PALFINGER shares are in free float.

Sec. 243a (4) UGB

There are no PALFINGER shares with special rights of control.

Sec. 243a (5) UGB

Within the PALFINGER Group there are no employee stock option programmes under which the shares in PALFINGER AG are not directly held by employees participating in the stock option programme.

Sec. 243a (6) UGB

The Articles of Association do not contain any provisions on the appointment of the members of the Management Board and the Supervisory Board and on amendments to the Articles of Association that exceed the scope of the respective statutory provisions.

Sec. 243a (7) UGB

As of 31 December 2007 the Management Board of PALFINGER AG was not authorised to issue and repurchase shares of PALFINGER AG beyond the scope of the respective statutory provisions.

Sec. 243a (8) UGB

No agreements that would become effective, be changed or terminated upon a change in management control have been entered into.

Sec. 243a (9) UGB

No agreement on compensation in the event of a public take-over bid has been entered into between PALFINGER AG and the members of its Management Board and Supervisory Board.

Group Assets, Finances, and Earnings

Group Assets

Total assets rose by 29.1 percent as compared to the previous year and amounted to EUR 528.3 million (previous year: EUR 409.4 million) as of 31 December 2007. A substantial factor contributing to this improvement was the initial consolidation of the MBB Group as of 31 December 2007.

The acquisitions of the Croatian company PiR metal d.o.o. and the German MBB Group resulted in an increase in goodwill by EUR 22.5 million. Non-current assets increased by 54.6 percent to EUR 238.9 million (previous year: EUR 154.6 million), which was higher than expected. This increase was primarily due to the investments in capacity expansion, rationalisation, and quality, a process extending over several years, and the additions to property, plant, and equipment resulting from the aforementioned acquisitions.

To a considerable extent the initial consolidation of the MBB Group was responsible for the 28.9 percent plus in non-current liabilities to EUR 66.3 million (previous year: EUR 51.4 million). The financing of the company aircraft by means of a finance lease also contributed to this increase.

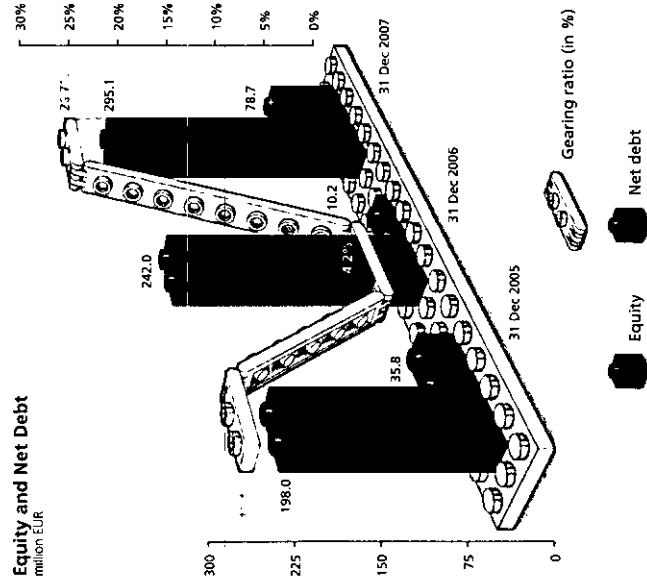

million EUR	31 Dec 2007	31 Dec 2006	31 Dec 2005
Abbreviated consolidated balance sheet			
Non-current assets	238.9	154.6	147.6
Current assets	289.4	254.8	201.0
Total assets	528.3	409.4	348.6
Equity	295.1	242.0	198.0
Non-current liabilities	66.3	51.4	34.5
Current liabilities	167.0	116.0	116.1
Total equity and liabilities	528.3	409.4	348.6

The gearing ratio went up due to the need for increased funds generated by the comprehensive investment programme and the previously mentioned acquisitions, but at 26.7 percent (previous year: 4.2 percent) it is still at a very low level.

Group Finances

The funds reported in the consolidated cash flow statement correspond to the balance sheet item cash and cash equivalents.

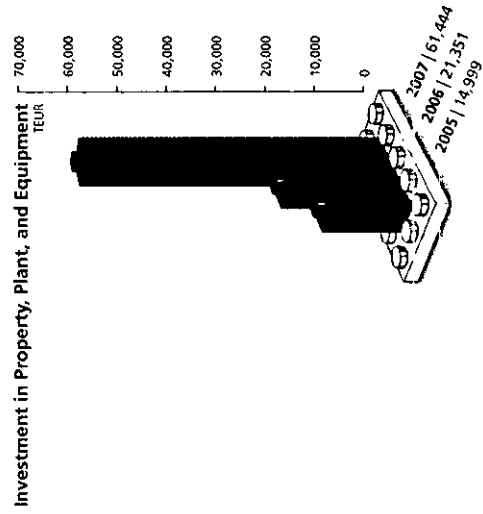

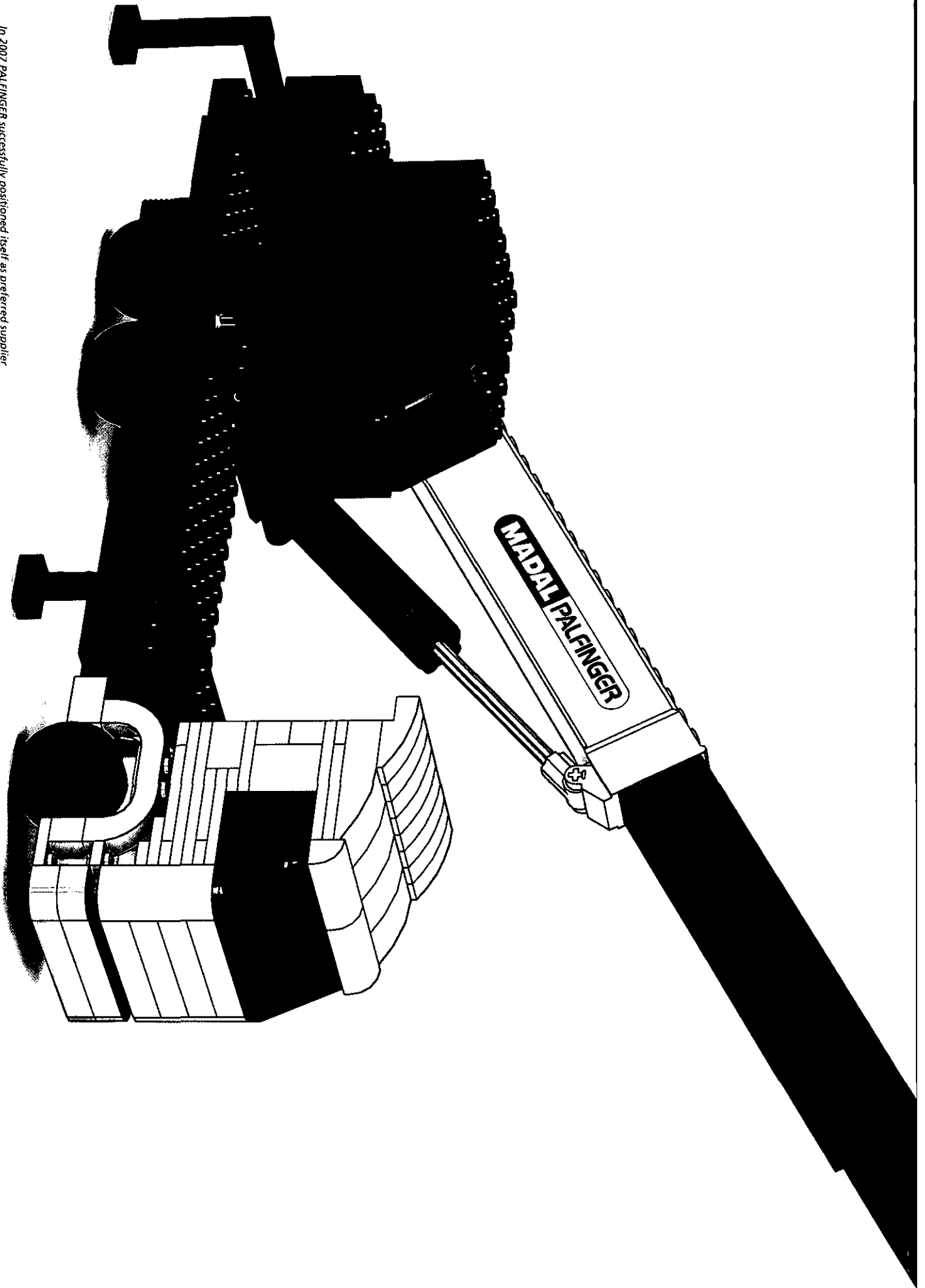

*In 2007 PALFINGER successfully positioned itself as preferred supplier
in the key account area of the South American market.*

In the 2007 financial year the **cash flow from operating activities** amounted to EUR 53.0 million, compared to EUR 59.5 million in the previous year. The decline was mainly due to the increase in working capital as a consequence of the Group's business expansion and to higher income tax payments because of improved earnings.

Cash outflows from investing activities rose by EUR 61.1 million to EUR 80.0 million (previous year: EUR 18.9 million) in the 2007 year under review. This was mainly caused by the cash outflows in the amount of EUR 24.7 million for acquisitions and the increase of EUR 40.0 million in cash payments for investments in property, plant, and equipment. The main investment focuses were the hexagonal tube production plant at the site in Lengau and the enlargement of the factory workshop at the site in Cherven Briag.

PALFINGER's strong expansion, which is reflected in the Company's cash investing activities, was to a large extent financed from operating cash flows. This led to a decrease of EUR 10.6 million in **cash outflows from financing activities** during the 2007 financial year to EUR 1.0 million – with the dividend payment being EUR 3.0 million higher – as compared to the same period of the previous year.

As a consequence of the high investment volume the **free cash flow** decreased by EUR 66.9 million to EUR – 23.2 million (previous year: EUR 43.7 million) during the 2007 financial year.

million EUR	Jan-Dec 2007	Jan-Dec 2006	Jan-Dec 2005
Free cash flow			
Cash flows from operating activities	53.0	59.5	42.7
Cash flows for investing activities	(80.0)	(18.9)	(35.9)
	(27.0)	40.6	6.8
Adjusted interest on borrowings after tax	3.8	3.1	2.6
Free cash flow	(23.2)	43.7	9.4

Group Earnings

In the 2007 financial year **revenue** rose by 18.9 percent to EUR 695.6 million (previous year: EUR 585.2 million). Once again, the knuckle boom crane division was the main contributor both to sales revenues and revenue growth. With a share of 77.8 percent in the Group's revenues (previous year: 76.5 percent) the European Union (EU) remained the most important sales market in the 2007 financial year.

Materials and external services rose to EUR 371.0 million while materials intensity remained almost unchanged at 52.5 percent (previous year: 52.7 percent).

Revenue by Region in %

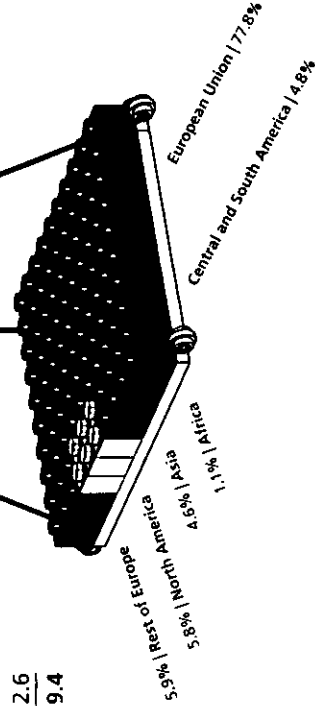

Performance of PALFINGER

The 14.9 percent increase in staff costs resulted from salary increases based on collective bargaining agreements and individual salary increases as well as from an increase in the average number of employees on the Group payroll of 12.1 percent.

EBIT for the 2006 financial year was lower due to an impairment loss for the company building at Berghheim, Salzburg in the amount of EUR 2.0 million. After the business location concept was changed, the impairment loss was adjusted to EUR 1.8 million in the 2007 financial year. This positive effect was, however, opposed by the higher depreciation in connection with the current investment programme.

The improvement of the financial result from EUR – 1.4 million to EUR 2.8 million was mainly due to the increase of 173.3 percent in income from associated companies.

Income tax expense rose by 52.9 percent as compared to the previous year, thus amounting to EUR 24.3 million (previous year: EUR 15.9 million) while the effective tax rate went up to 23.8 percent (previous year: 21.0 percent). The lowering of the tax rate in the course of the corporate tax reform in Germany was reflected in a deferred tax expense of EUR 0.3 million. The positive effects of the reform were more than compensated by the capitalised loss carryforwards.

On the basis of the positive revenues and earnings situation, the Management Board proposes to distribute a dividend in the amount of EUR 0.70 per share (previous year: EUR 0.55, prior to the stock split: EUR 2.20).

million EUR

Abbreviated consolidated income statement	Jan-Dec 2007	Jan-Dec 2006	Jan-Dec 2005
Revenue	695.6	585.2	520.0
EBITDA	115.3	92.1	77.5
EBITDA margin (in percent)	16.6	15.7	14.9
EBIT	99.6	77.0	65.1
EBIT margin (in percent)	14.3	13.2	12.5
Net financial result	2.8	(1.4)	(1.2)
Consolidated net profit for the period	74.0	56.6	48.1
Earnings per share (in EUR) ²⁾	2.09	1.60	1.37
Dividend per share (in EUR) ^{1) 2)}	0.70	0.55	0.45

¹⁾ Proposal of the Management Board to the Supervisory Board for presentation to the Annual General Meeting for resolution.

²⁾ Previous year's figures were converted pursuant to the stock split.

As a consequence of the proportional increase in net operating profit less adjusted taxes (NOPLAT) and the average capital employed, the return on capital employed (ROCE) was 25.7 percent as in the previous year. The 28.7 percent rise of the average capital employed was mainly caused by the comprehensive investment programme and the stepping up of inventories due to the high order intake. NOPLAT was positively impacted by the income from associated companies, which was EUR 3.6 million higher than in the previous year, and by EBIT, which rose by 29.4 percent.

Calculation of ROCE	Jan-Dec 2007	Jan-Dec 2006	Jan-Dec 2005
EBIT	99.6	77.0	65.1
Income from associated companies	5.8	2.1	2.1
Adjusted income tax expense	(25.1)	(16.8)	(14.2)
NOPLAT	80.3	62.3	53.0
Non-current assets	196.8	151.1	134.6
Non-current interest-bearing assets	(0.8)	(1.6)	(1.9)
Non-current operating assets*	195.9	149.5	132.7
Inventories	133.1	106.9	92.5
Receivables and other current assets (excluding securities)	116.0	97.4	91.4
Current tax receivables	3.6	5.1	5.5
Non-current and current provisions	(33.5)	(39.9)	(45.1)
Deferred tax liabilities	(3.0)	(0.1)	(0.5)
Current tax liabilities	(9.1)	(5.6)	(3.1)
Other non-current and current liabilities	(90.4)	(70.3)	(62.2)
Net working capital*	116.7	93.4	78.6
Capital employed*	312.6	243.0	211.3
ROCE (in percent)	25.7	25.7	25.1

*1) average

With the ROCE remaining unchanged, the economic value added (EVA) was increased by 29.8 percent to EUR 54.5 million (previous year: EUR 42.0 million) in the 2007 financial year and resulted from the rise in average capital employed by 28.7 percent. The decline in weighted average cost of capital (WACC) was due to the change in the effective tax rate by 2.8 percentage points.

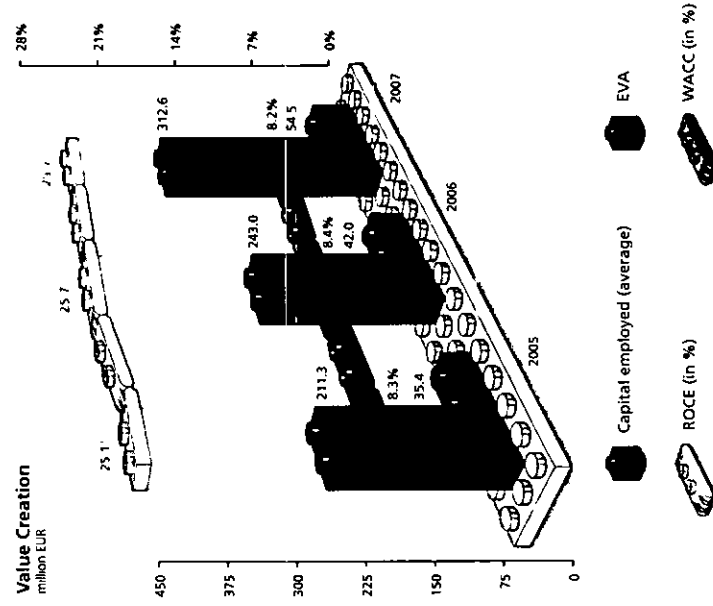

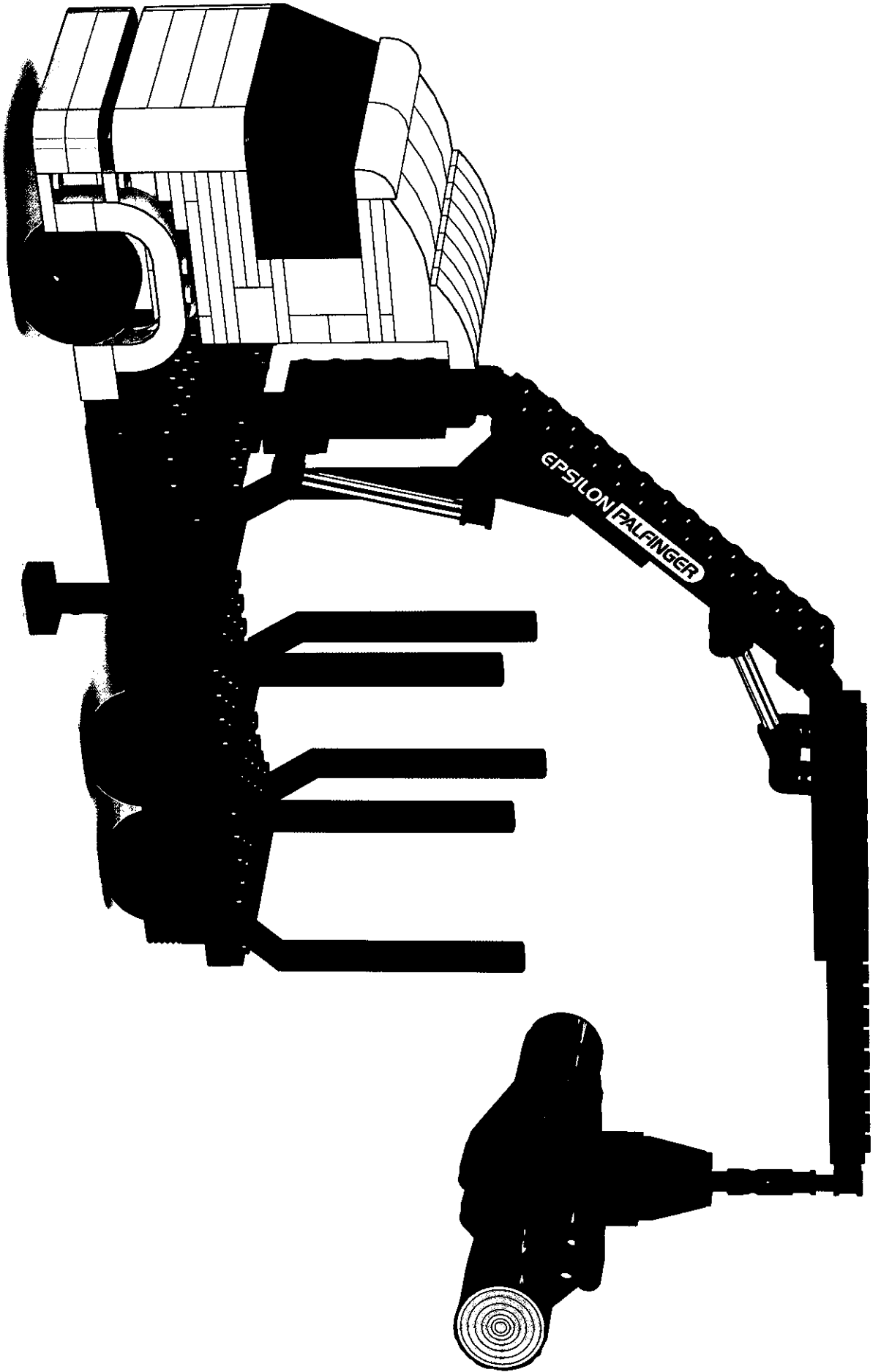

In 2007 PALFINGER gained additional market shares and became the global market leader in timber and recycling cranes.

Putting financial building blocks in the right order

Treasury

Organisation

In order to make the best possible use of central synergy effects and local opportunities, decisions on financial services are made by the Group Treasury in coordination with the local units. The structures and processes regarding the treasury tasks to be performed both within PALFINGER AG and in relations between Group companies are laid down in the Treasury Guidelines.

Treasury responsibilities include cash and liquidity management, the determination of banking policy, financing and/or investments, and financial risk management within the Group.

The objectives include guaranteed liquidity, profitability of banking and financial services bought in from third parties, and limiting financial risks while optimising revenues and costs. All processes are transparent and traceable, and their efficiency is optimised continuously using special treasury software. With this software the data are available for analyses and for data linking once they have been captured. All entries of data are logged automatically so that all changes are traceable at any time to ensure transparency.

The treasury software is used for current cash reporting, the management of financing and the management and valuation of the foreign currency positions, as well as for the reconciliation of intercompany accounts receivable and accounts payable. *This system support increases the efficiency of the reconciliation process. All steps taken are documented, the result is summarised in a report and stored in the computer system.*

Cash and Liquidity Management

The Group-wide liquidity position forms the basis for controlling liquidity within the Group. One of the objectives of cash management is to prevent the simultaneous existence of credit and debit balances in the bank accounts and the consequential loss of interest. In addition, banking terms and conditions are monitored and optimised continuously.

The maturities of the loans are structured according to risk aspects. Care is taken to ensure that multiple simultaneous facility expiries are avoided.

Performance of PALFINGER

The objective of liquidity control is to provide the funds required for the continued implementation of the investment programme and/or for further profitable growth. Liquidity generated from the operating business is ploughed back into the Group's investment programme. Should additional capital be required, short-term loans are raised. Excess liquidity, which may accrue for short periods of time, is invested in the money market, always paying attention to ensure the highest level of financial product security, the best issuer credit rating, and the availability of the funds at any time.

Both financings and investments are subject to ongoing credit ratings and market risk analyses. Short lock-in periods allow for quick reactions to changes in market situations and, if required, to deteriorations of the credit ratings of contract partners.

Foreign Currencies

The year 2007 was characterised by the significant weakness of the US dollar as the "global currency". The US dollar continued the previous year's strong depreciation against the euro in 2007. The US real estate and liquidity crises that started in the middle of the year gave rise to major insecurity among financial market participants and impacted nearly all markets.

PALFINGER constantly assesses the foreign exchange exposure of the Group and of the individual companies by means of simulations, scenarios, and the "value at risk" concept. The value at risk indicates the statistical level of maximum loss to be expected from a risk position assuming a given probability of occurrence within a given timeframe. On the basis of these risk indicators the foreign currency team, which is made up of members from various departments, prepares suggestions that serve the Management Board as a basis for their decision-making regarding the hedging strategy for outstanding foreign currency positions.

In line with the Group's internal principles, PALFINGER only enters into hedging transactions for which mark-to-market valuation and posting is possible. The Group's own valuations of the transactions are checked for plausibility using the relevant tradeable market values at the respective reporting date. The hedges are posted in line with the hedge accounting principle according to standard IAS 39 of the International Financial Reporting Standards.

Like all other treasury tasks, the trade in foreign currencies is subjected to the four eyes' principle. The internal trading confirmations which must be issued are compared to the confirmations from the respective transaction partners by a unit that is independent from the broker. The transactions are also posted by a unit independent from the broker.

Our building plans also take account of risk

Risk Report

Risk Management System

The strategic objectives of PALFINGER and the continuous growth of the Company entail numerous challenges. In addition to the basic components of a risk management set-up, such as standardised Group-wide planning and controlling processes and intercompany standards and reporting systems, PALFINGER increasingly focuses on a Company-wide uniform risk control system. This is supported by the Corporate Risk Management position established at Group level, which reports directly to the Management Board. PALFINGER considers a functioning, systematically organised opportunities and risk management system to be an important contribution to maintaining and expanding competitive advantages.

The aim is to use a systematic approach to identify opportunities and risks at an early stage so as to be able to proactively respond to changing framework conditions. The managements of the corporate areas and divisions identify the most important opportunities and risks along the process chain once a year, taking external factors into consideration. On the basis of this analysis the existing measures are documented and further measures for active risk control are developed and implemented. The corporate risk management department also carries out periodic checks in order to make sure that the planned measures are implemented within the deadlines set.

The internal auditing department furthermore monitors adherence to the statutory framework and the Company's internal guidelines. It also examines the general functionality of the risk management system with respect to the early identification of risks that might jeopardise the continued existence of the Company.

Existing Risks

Economic Risks

PALFINGER's strong presence in the markets of the eurozone means that a weakening of economic growth in the European Union would have negative effects on the Company. Although the crisis in the US real estate market has already impacted the Group through the sales figures for its North American subsidiary, it will only gain strategic relevance if the crisis spills over to Europe.

Market Risks

A major factor in the industry is the increasing competitive pressure in all markets. The Group seeks to continuously reduce its dependence through a strategic approach regarding innovation, internationalisation, and diversification.

Performance of PALFINGER

Development Risks

PALFINGER is known in the market for its high level of quality and its progressive developments. In order to be able to maintain this status the Company must strongly focus on research and development. It is particularly vital that PALFINGER succeeds in continuing to meet the requirements of the market in an optimal manner with its products and services. To ensure that a competitive cost situation can also be achieved with newly developed products, all value-creation phases are included in the development process at a very early stage.

Procurement Risks

PALFINGER is exposed to price fluctuations in the market for raw materials. Late deliveries, failure to deliver, or quality deficiencies may also lead to disruptions of production that would negatively affect PALFINGER's earnings. In order to actively control the delivery situation, PALFINGER has implemented special supplier selection procedures using monitoring processes and supplier management systems.

Manufacturing and Assembly Risks

The most important stages of the value-creation chain of PALFINGER are the manufacturing and assembly of products. These processes give rise to a series of risks with potentially negative impacts on the Group's earnings. These risks are limited by measures such as systematic training programmes for employees, constant refinement of production processes, or a service and maintenance concept for all facilities and systems.

PALFINGER has implemented a lean production system to increase process efficiency, quality, and flexibility. If this system is not complied with or developed according to plan, this could also have a negative influence on PALFINGER's earnings position.

We have taken out adequate insurance cover for energy supply failure, technical failure, fire, explosions, and other possible disruptions.

Quality Risks

PALFINGER has implemented an ISO 9001 certified quality management system. Standardised processes are in operation throughout the Group, which allow for a common approach to avoiding and/or identifying and rectifying failures. In spite of this efficient and systematic quality management approach within PALFINGER it is impossible to fully exclude the risk of product liability. Although we have insurance cover to meet such costs, the related damage to PALFINGER's image would be considerable.

Human Resources Risks

PALFINGER is aware that its employees are one of the most important factors of its success. Special planning and ongoing staff reviews ensure the necessary succession of management and skilled labour. In particular at the PALFINGER sites in Eastern Europe, special emphasis also has to be given to the development of highly qualified skilled labour in order to be able to meet the growth targets of the periods ahead.

Foreign Currency Risks

PALFINGER engages in worldwide operations, which exposes the Company's earnings to currency fluctuations. This is particularly true for revenue generated in North America and Brazil. Currency risks are evaluated continuously as part of a central currency management system, and hedged using adequate financial instruments, or mitigated by boosting local value creation.

Credit Risks

PALFINGER has implemented precautionary measures that limit the probability of losses on doubtful receivables. Defining processes in cooperation with partners to ensure an efficient and effective process is of importance to PALFINGER. The nature of cooperation is challenged on a regular basis and potential for improvements identified.

IT Risks

The operational and strategic management of PALFINGER relies on complex information technology (IT). Highly qualified internal and external experts maintain and optimise the IT system across the entire Group. PALFINGER also has in place a range of technical security and protective measures to minimise the risks of unauthorised access to data, the misuse of data, and data loss.

Portfolio Risk

PALFINGER pursues a strategy of diversification with the long-term goal of reducing its dependence on the market for truck-mounted knuckle boom cranes. The majority of other product groups are still generating modest profits. If the growing competitive pressure in the market for cranes were to lead to a significant decline in margins, PALFINGER would come under considerable pressure in maintaining overall profitability.

Overall Assessment

There are currently no discernable individual risks that might jeopardise the continued existence of the Company.

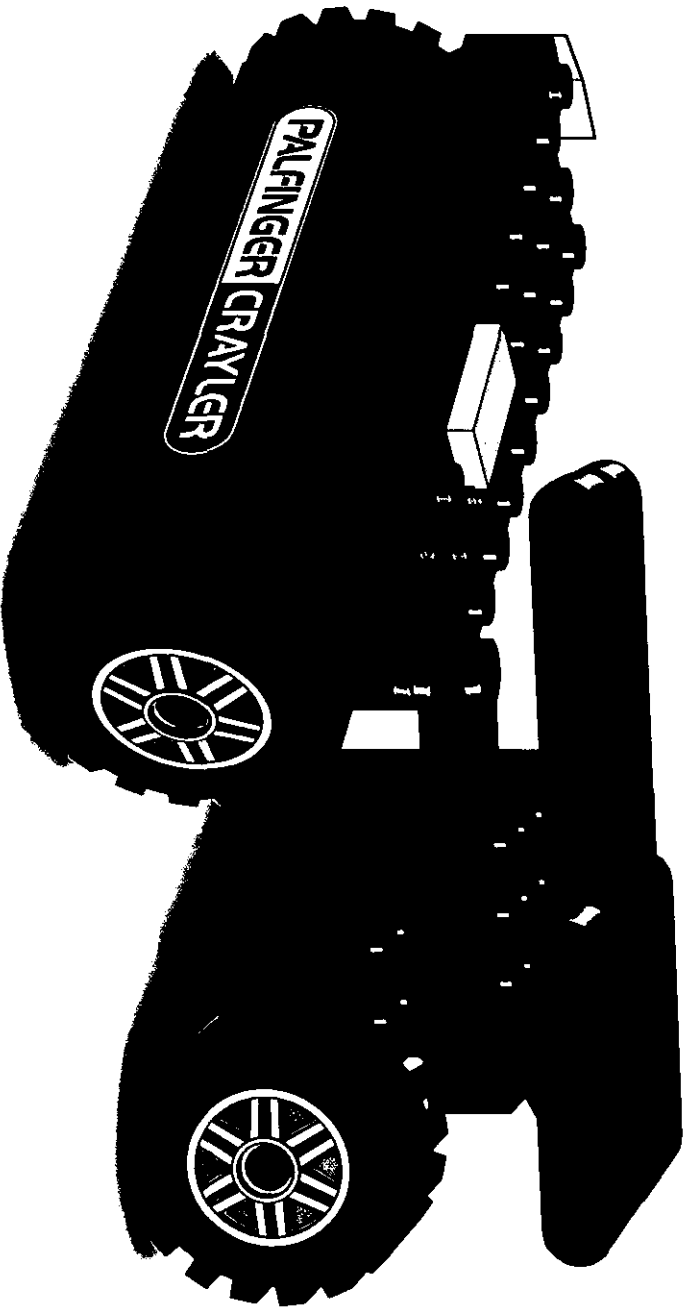

*At the Group's research and development centre in Kötendorf also
CRAYLER transportable forklifts will be further developed in the future.*

We will leave no brick unturned in order to be successful tomorrow and beyond

Research, Development, and Innovation

In the course of the currently implemented measures to increase capacity, an evaluation and/or reorientation of all sites was performed. This strategic site optimisation process led to the identification of the Austrian business location in Köstendorf as the Group's future research and development centre.

The plant in Köstendorf, Austria, was developed into research and development centre for truck-mounted knuckle boom cranes, CRAYLER, RAILWAY, and hydraulic

As of the end of 2007 the following product divisions and centres of excellence were located at the R&D centre Köstendorf:

- Truck-mounted knuckle boom cranes
- CRAYLER transportable forklifts
- RAILWAY system solutions
- Centre of excellence for hydraulics

The trial and endurance testing department and the centre of excellence for electronics will follow in 2008, the R&D departments of the other product divisions will remain at their present international locations.

Focus of Activities in 2007 *Patents and Ideas*

An internal patent database was installed in order to provide all engineers and developers with easy and efficient access to all valid patents of PALFINGER and its competitors. This database is to serve as a basis for determining the state of the technology on the one hand and as a source of ideas for new solution approaches on the other. As of 31 December 2007, PALFINGER AG held 48 active patents across all product divisions.

Performance of PALFINGER

Ergonomics and Functional Design

The majority of design innovations are aimed at increasing functionality and implementing the latest ergonomic findings in the area of the human-machine interface.

Process Innovations in the Value-Creation Area

A new fully automated hexagonal tube assembly line for processing high-strength fine-grained structural steel started up at the production site in Lengau in September 2007. This new assembly line will not only make increases in production capacities possible but also guarantee even higher product quality and process security. This will enable PALFINGER to further expand its technology leadership. At the Maribor plant, a large components centre started operations in which structural steel elements with a component size of up to 10 metres are manufactured. This large components centre will be further expanded in 2008.

R&D Investments

In 2007 PALFINGER invested EUR 13.7 million in research and product development, which corresponds to 2.0 percent of its total revenue. This sum does not include investments in buildings and infrastructure for the R&D site Kötendorf.

Product Development

Truck-mounted knuckle boom cranes

In 2007 the emphasis was on the market presentation and market launch of the first models of the new *High Performance* crane generation. The ratio between the lifting moment and the cranes' dead weight was further optimised in this crane series due to the increased use of high-tension steel. This also led to an enhancement of the lifting moment by up to 10 percent as compared to comparable predecessor models. Another bonus is that the Power Link Plus knuckle boom, which is tiltable upwards by 15 degrees, is also available in the 10-metric tonne category of the *High Performance* series.

With its new maintenance-free extension system PALFINGER contributes significantly to service friendliness and environmental protection. Intensive testing led to the development of sliding blocks made from a special synthetic material that have self-lubricating qualities. In addition, the control panels were reengineered and now meet the latest functional and ergonomic requirements. The approximately 80 models of the *High Performance* crane series will be introduced to the market progressively over the next three years.

EPSILON

The development and market launch of the unique Triple Z crane geometry was a milestone in 9-metric tonne to 16.5-metric tonne recycling cranes. The innovative telescopic main boom allows for an enormous hook height in all Triple Z crane models for the optimal handling of bulky loads and the loading of containers, as well as for a very short parking length. The parking options of the crane were adjusted to the changed structural design of the new trucks that comply with the Euro 4 or Euro 5 emission standards.

In order to make the work of crane operators in continuous forestry and recycling operations as agreeable as possible, a mechanical and an X-large comfort cabin were added to the existing crane cabin portfolio.

PALIFT

The R&D focus in 2007 was on the completion and market launch of the New Power Range models, designed for lifting extremely heavy loads. With the new PAK 13H skip loader it was furthermore possible to set new standards in container security and anti-tipping devices.

The new development of a bolt-on supporting frame made the assembly of the hook loader to the truck's underframe much easier. Another step towards increased modularity is the development of an adjustable underrun protection device that can be used with all commonly used truck models without any modification.

TAIL LIFT – PALGATE

The acquisition of MBB permitted the implementation of a significant expansion of the PALFINGER tail lift portfolio. In the future, all R&D activities regarding traditional tail lifts for markets in Continental and Central Europe and North America will be performed centrally at the MBB site in Ganderkesee, Germany. For the RATCLIFF division, an additional R&D centre of excellence will be implemented, primarily for column lifts and passenger lifts.

TAIL LIFT – RATCLIFF

The passenger lift portfolio for the market in Great Britain was expanded by adding two additional C-Thru-Lift models and the new generation of underfloor lifts with increased payload.

In the traditional tail lift segment, development concentrated on retractable tail lifts of the Level Ride type, focusing on making the installation on the vehicle's chassis as simple as possible. With the new Tukaway, an ultra light tuckaway tail lift, an optimal platform has been designed especially for 7.5-tonne vehicles with box bodies.

Performance of PALFINGER

BISON

The market introduction of the new TA series was a milestone in the 3.5-tonne category. The economical combination of aluminium and compound fibre materials made it possible to implement the desired increase in outreach at the same dead weight of the aerial work platform. The innovative design of the platform and in particular of the safety cage highlights the synergies of functionality and design. In the area of the control system and electronics the modular concept was implemented step by step, using basic modules from the field of truck-mounted knuckle boom crane control.

CRAWLER

In the area of the 4-way and scissor-type forklifts three new models were added to the portfolio. Thanks to a new mast design, the installation length of the forklifts could be reduced further, bringing the centre of gravity even closer to the vehicle. In North America PALFINGER started to build up local R&D resources in order to be able to meet the North American market requirements and cater to the needs of the final customers in an even more target group oriented manner.

R&D Cooperation Ventures in 2007

Another lead user project was started with the Institute for Entrepreneurship and Innovation at the Vienna University of Economics and Business Administration with the aim of developing an innovative problem-solving and/or idea-finding approach. The focus of the project is on finding new design solutions for transportable truck-mounted forklifts.

In the fields of material and processing technologies, specific projects with research institutes at and outside of universities were carried out.

Our most important players

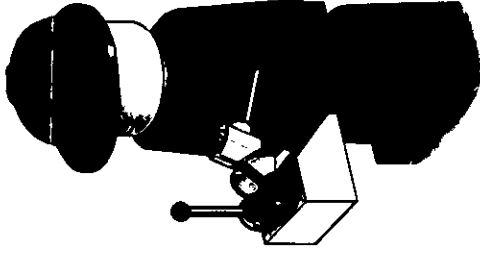

Human Resources

The increase in production – due to the gratifying development of order intake – continued to pose a challenge for all employees during the 2007 reporting year. The PALFINGER Group has been using modern working time regulations based on flexitime and bandwidths as well as performance and profit-related remuneration systems for many years. These regulations, which are constantly expanded and improved, are highly appreciated by the Company's staff.

The recruitment of skilled labour at the production locations has been a factor of special importance. In 2007 PALFINGER initiated additional employee retention programmes to guarantee the availability of human resources over the longer term.

Since 2004 the methods and principles of Lean Management have been applied at nearly all manufacturing and assembly plants. These include PALFINGER's Rapid Process philosophy as well as World Class Manufacturing and are based on the standardisation and visualisation of processes and on One-Piece flow production. The employees undergo intensive training in these methods to enhance value creation. To implement the methods, they work in teams that are largely self-controlled. The opportunity to take responsibility for structuring and improving important components of their work has been received very positively by PALFINGER's employees and reflected in their stronger commitment.

World Class Manufacturing

Strategic levers:

- Process efficiency
- Flexibility
- Quality
- Human resources development

Objectives:

- Customer orientation: aiming to achieve the best possible advantage for customers
- Value creation: preventing waste
- Standardisation: reducing the complexity of products and processes

Performance of PALFINGER

the most important success factor of a company is employees. This is why PALFINGER promotes education and further training as well as health and motivation.

Internally-targeted roadshows are hosted regularly at various locations in order to foster bonding within the Group and in order to inform staff members about strategies and the progress of individual projects. Regular management team meetings ensure efficient flows of information and decision-making processes.

Twice a year a brief staff survey is performed at all Austrian and international PALFINGER locations. In most cases, questions are answered via the Internet. The results form part of the internal performance indicators and are intensively discussed with the employees and in management meetings. This makes it possible to identify developments within the Group at an early stage and to formulate reactions.

PALFINGER's internal PALfit health programme was further expanded in 2007. The programme, which comprises broad preventive medical checkups, sports and fitness options, physiotherapy, and informational lectures, was introduced at the German sites in Airring and Löbau and the French business locations over the past year. At the EPSILON site, a pilot project in cooperation with the local health insurance company Salzburger Gebietskrankenkasse was started in the course of which the employees can develop their own suggestions for improvement. Following large-scale reconstructions at the plants in Maribor, Červen Brjag, and Tenovo, analyses of the status quo are being carried out. PALfit will then be introduced gradually, depending on priorities and needs. All measures to improve staff health aim at including all employees and raising their awareness that they are personally responsible for leading a healthy life.

The education and further training of its employees is of great importance to PALFINGER. This is especially vital in times of constantly evolving markets and rapid technological change. The annual appraisal interviews are the basis for individual development plans. In 2007, 350 Austrian staff members attended a total of 1,511 training days. Approximately a quarter of the courses were offered within the framework of the PALFINGER College, the Company's own internal training and development programme. At the international locations, teaching and training skilled labour, in particular with a view to World Class Manufacturing, was a dominant issue.

In order to prevent a shortage of highly qualified managers within the PALFINGER Group, the demand necessitated by the strategy of the Company is evaluated in annual management conferences as well as at other reporting levels, so that succession planning and the promotion of talented staff embrace the entire organisation. Two internal management development programmes are being carried out for this target group with participants from various areas of the PALFINGER Group. The aim is to bring about a greater number of foreign assignments for our managers.

The increasing internationalisation is also reflected in the number of employees posted abroad: In 2007 up to 38 employees from Austria were assigned to international locations, making an important contribution to knowledge transfer as well as cultural networking within PALFINGER.

The comprehensive implementation of the new human resources information platform, PALFINGER PeopleNet, was started in the period under review. Real-time operations will be taken up at the Austrian sites in the second quarter 2008 and additional international sites will be included starting from the third quarter. With this system, the skills and experience of the employees can be presented in a transparent manner and further developed, resulting in a win-win situation for all.

As of the end of the year 2007, PALFINGER employed 4,377 staff members (excluding temporary workers and apprentices) in the 26 fully consolidated Group companies. 65 apprentices received training during the reporting year. On the annual average 3,860 staff members (excluding apprentices) were employed; in addition 311 temporary workers were hired during capacity bottlenecks.

The heart of a company and therefore the most important success factor are always its employees. For this reason PALFINGER regards the development and motivation of the staff as an important investment in the future. The Group's objective for the coming years is to jointly optimise the Company and its processes. This will lead to the continued improvement of the Company's ability to create value and will make PALFINGER even more attractive.

Employees by Region
as of 31 December 2007

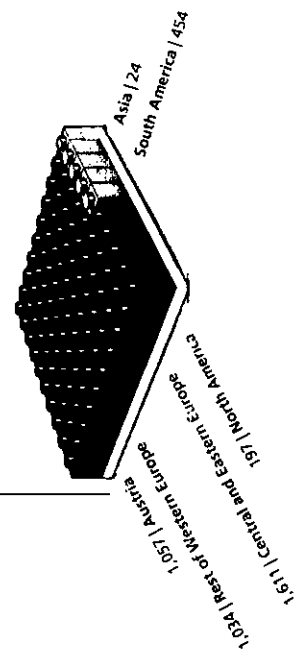

Performance of PALFINGER

Investor Relations

International Stock Markets

In 2007 stock exchanges saw exceedingly wide price fluctuations, with the majority of them in a year-over-year comparison managing to show a narrowly positive performance of the respective share index.

After a first correction at the end of February, initiated by the Shanghai Stock Exchange, the subsequent months saw a highly gratifying development. Fuelled by positive business results as well as numerous take-overs and mergers, between the end of May and mid-June many stock market indices achieved new absolute records or at least their highest levels in several years. The second half was dominated by the impact of the US subprime mortgage financial crisis. As a result, financial institutions suffered heavy losses, and the willingness of private and institutional investors to take risks sharply declined. The development of share prices was also dampened by fears regarding economic trends and inflationary concerns, triggered by high oil, raw materials, and food prices. Central banks contributed towards a stabilisation of the markets by providing extra liquidity and by taking adequate interest rate measures. Contrary to what many analysts expected for autumn 2007, the ECB did not raise interest rates, and the US Federal Reserve repeatedly lowered the federal funds rate after the summer.

Vienna Stock Exchange

In the first half year the Austrian stock market was spurred by favourable economic and corporate figures as well as by business take-overs. On 9 July 2007, the Austrian Traded Index ATX closed at an all-time high of 4,981.87 points, only to slump afterwards in line with international trends. Real estate stocks were hit especially hard by this slide. These stocks are not included in the ATX index but still have a strong presence on the Vienna Stock Exchange, and thus their decline – evidenced by the fact that the LATX, the Austrian benchmark index for the real estate sector, at times dropped by 40 points as compared to its high for the year – was to blame for the gloomy sentiment on the stock exchange.

The effects of the subprime crisis continue to impact the share price performance on the Austrian stock market. After the marked declines witnessed in the third quarter, both the fourth quarter 2007 and the first four weeks of 2008 were characterised by volatile price movements.

However, a total of more than 10 billion euros in fresh inflowing capital was raised by initial public offerings (IPOs) and capital increases, which made it possible roughly to maintain the exceedingly high level of 2006. Seven companies were admitted to trading on the Vienna Stock Exchange. The overall market capitalisation in 2007 jumped to more than EUR 157 billion. The ATX ultimately closed with a plus of 1.1 percent, corresponding to a narrowly positive price performance.

the PALFINGER share was also affected by the global trend but still reached an annual performance gain of 10 percent in 2007.

The PALFINGER Share

The PALFINGER share is listed in the Prime Market on the Vienna Stock Exchange and in the VIX – the index of shares with a growth and value-orientation. Since 2005 the PALFINGER share has also been a constituent of the Austrian VÖNIX sustainability index. In Germany, it is traded over the counter in Frankfurt, Stuttgart, Berlin, Munich, and Düsseldorf. Since March 2005, there has been an ADR Level 1 listing in New York.

As of 29 June 2007, a 4-for-1 stock split of the PALFINGER shares was implemented increasing the number of shares from 9,283,750 to 37,135,000. At the same time the price of PALFINGER shares was adjusted to a fourth of the most recently quoted price.

In 2007 the price of the PALFINGER share developed in line with the Austrian stock market and/or international stock exchanges. The first half 2007 saw steep price increases, leading to an all-time high of EUR 42.84 (after the stock split) on 1 June 2007. The second half was characterised by volatile price movements, forcing the Company to forfeit the lion's share of its price increase. At a price of EUR 25.62 as of the end of the period under review, the PALFINGER share price for the full year showed a gain of 10 percent.

The Management Board of PALFINGER AG held numerous roadshows in Europe and North America in 2007. Moreover, PALFINGER was represented at investor fairs such as the GEWINN trade fair in Vienna, Invest in Stuttgart, and at stock exchange days held in Germany, for example in Munich and Nuremberg.

In 2007 PALFINGER AG once again received numerous awards for its investor-relations work and for the Annual Report 2006.

Dividend

Subject to the approval of the Annual General Meeting, the Management Board proposes to distribute a dividend in the amount of EUR 0.70 per share. The own shares held by PALFINGER AG do not qualify for dividend distributions. Relating to the average price of the PALFINGER share in 2007 (EUR 32.82) the distribution corresponds to a dividend yield of 2.1 percent, relating to the price as of the end of the period under review to a dividend yield of 2.7 percent.

Ownership Structure

As of 31 December 2007, 62 percent of PALFINGER AG was either directly or indirectly owned by the Palfinger family. PALFINGER AG held around 5 percent of the shares from the share repurchase scheme, which had ended in 2003. The remaining 33 percent of the shares were in free float. According to information available to PALFINGER AG about three quarters of the free float are held by primarily European institutional investors.

Shareholder Structure
in %

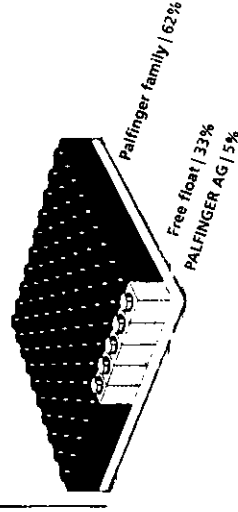

Performance of PALFINGER

Shareholder Information

ISIN	AT0000758305
Number of shares issued	37,135,000
Own shares	1,805,000
Shares in circulation	35,330,000
Listing on the Vienna Stock Exchange	Prime Market
OTC listings	New York, Frankfurt, Stuttgart, Berlin, Munich, Düsseldorf
Ticker symbols	Reuters: PALF.VIE, Bloomberg: PALF.AG, Vienna Stock Exchange: PAL

	2007	2006*
Low	EUR 22.95	EUR 15.00
High	EUR 42.84	EUR 23.56
Average price	EUR 32.82	EUR 18.83
Price as of 31 December	EUR 25.62	EUR 23.25
Earnings per share	EUR 2.09	EUR 1.60
Operating cash flow per share	EUR 1.50	EUR 1.60
Proposed dividend per share	EUR 0.70	EUR 0.55
Dividend yield relating to the average share price	2.13%	2.92%
Market capitalisation as of 31 December (excl. own shares)	EUR 905.15m	EUR 820.48m

* Previous year's figures were converted pursuant to the stock split.

Share Price Development 2007

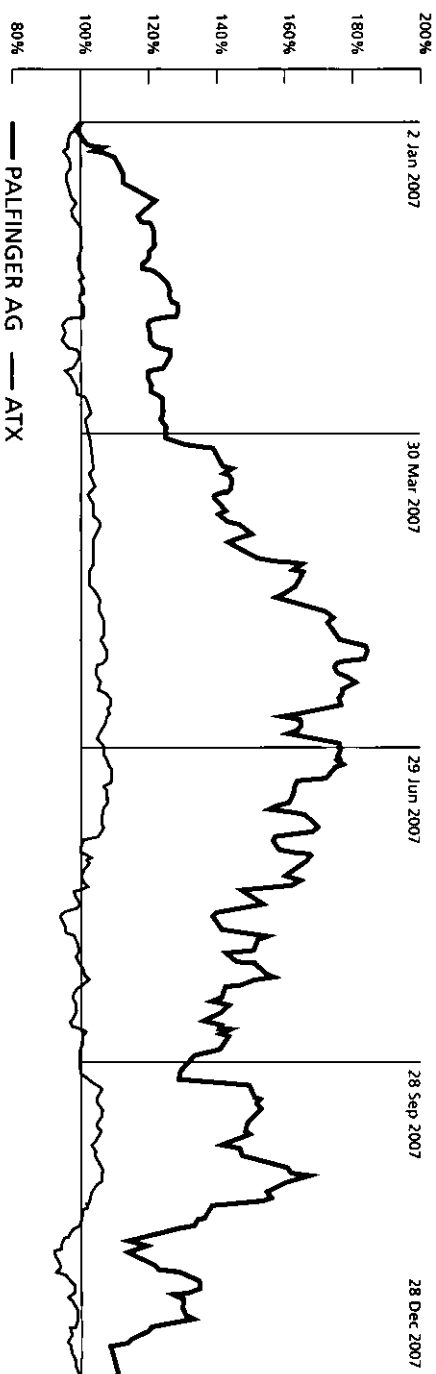

Research Reports

- Bank Austria Creditanstalt
- Berenberg Bank
- Deutsche Bank
- Erste Bank
- Merrill Lynch
- Raiffeisen Centrobank
- UBS

Investor Relations

Phone +43 662 4684-0, Fax +43 662 4684-2280, www.palfinger.com
 Wolfgang Anzengruber, Chief Executive Officer, ext. 2218,
 w.anzengruber@palfinger.com
 Hannes Roither, Company Spokesperson, ext. 2260,
 h.roither@palfinger.com

Corporate Governance

In the 2003 financial year, PALFINGER committed to the standards of the Austrian Corporate Governance Code (www.corporate-governance.at) and has since then complied with nearly all rules of the Code. The Company played a significant part in bringing about the Austrian Corporate Governance Code and will continue to actively contribute to the further development of corporate governance.

PALFINGER is one of the few companies in Austria that has not only committed to observing the Corporate Governance Code but also has its compliance evaluated. The evaluation result produced by an external auditor confirms that corporate governance is genuinely put into practice at PALFINGER. The way that the Management Board and the Supervisory Board work together is considered exemplary and serves to promote both the transparency of the Company and the controlling functions. Since the 2004 financial year the evaluation has been conducted once a year in the form of a questionnaire published by the Austrian Working Group for Corporate Governance. The questionnaire is completed and audited annually and then made available to all interested parties on the Company's homepage (www.palfinger.com).

PALFINGER satisfies the requirements of the binding L-rules (Legal Requirement) and adheres to all C-rules (Comply or Explain) of the Austrian Corporate Governance Code (in its revised version of 2007) with the following exceptions:

Rule No. 53 (Independent Members of the Supervisory Board)

PALFINGER does not fully comply with Rule No. 53. No criteria for independence have been established. Rather, PALFINGER AG publishes personal and qualification profiles of the members of the Supervisory Board and circumstances that might limit their independence on its homepage. On the basis of this information any shareholder as well as the public at large can gain insight into the qualifications of the members of the Supervisory Board and assess their suitability for their tenure.

Other than the Palfinger family, no member of the Supervisory Board has either a direct or an indirect shareholding of more than 1 percent in PALFINGER AG.

The performance of the Supervisory Board members has made a significant contribution to the success of PALFINGER AG in recent years. The well-balanced composition of the Supervisory Board, the diligent selection of the individual members according to their professional and personal characteristics, as well as their knowledge of the Company and of the entire sector, have been of the greatest importance in this respect.

Performance of PALFINGER

Rule No. 39 (Supervisory Board Committees)

The requirements of Rule No. 39 are satisfied in principle. The sole exception, as noted in the comments regarding Rule No. 53, is the third paragraph ("sufficient number of independent members in the committees").

Rule No. 51 (Remuneration Scheme for Members of the Supervisory Board)

It is not possible to establish a remuneration scheme since neither the Annual General Meeting nor the Company's Articles of Association have provided for a fixed remuneration of the members of the Supervisory Board.

Members of the Supervisory Board	First appointment	End of term of office
Alexander Exner	21 June 1995	AGM 2009
Hubert Palfinger	1989	AGM 2009
Hubert Palfinger jun.	13 April 2005	AGM 2010
Kurt Stiassny	14 November 1996	AGM 2012
Peter Scharler	14 April 2004	AGM 2012
Alexander Doujak	5 April 2006	AGM 2011
Johann Mair*	24 May 2005	*
Alois Weiss*	13 February 2006	*
Gerhard Gruber*	15 May 2006	*

* delegated by the Works Council

The basic building blocks for future success are in place today

Sustainability

In 2007 PALFINGER mapped out its strategy for sustainable development. The essential ecological and social issues were defined clearly and performance indicators were allocated to each issue. Key projects for environmentally sound production, safety and health of the employees, and regional responsibility mark the Company's path towards a responsible future.

After having invested maximally in the strategic definition of ecological and social issues during the reporting year, another sustainability report will be published in 2008 to document the development steps of the PALFINGER Group.

Central Ecological and Social Issues at PALFINGER *Regional Development*

In addition to their commitment to the business location Austria, the PALFINGER sites should give a positive impetus to the regions in which they are embedded. The surroundings benefit from local supplier relations, employment, tax contributions, and a gain in know-how. Starting from 2008 a regional development programme will be started in Bulgaria, which will further improve the motivation and identification of PALFINGER staff.

Equal Opportunities

At PALFINGER all staff members are given fair opportunities – irrespective of their age, their gender, their cultural background, or possible disabilities.

Education and Further Training

Developing the know-how of the staff is of utmost priority to PALFINGER. At the moment, special support is given to the locations in Eastern Europe and South America in the form of intensive training programmes.

Performance of PALFINGER

Health and Safety of the Employees

The well-being of the people who work with PALFINGER is of special concern to the shareholder representatives and the Management. The PALfit programme for improving the health of all employees has been carried out in Austria for several years. This programme will now be gradually expanded to include all international sites of the Company. Starting from 2008, a comparison of all PALFINGER locations as regards health and safety aspects will be made so that deficiencies, if any, can be remedied at an early stage.

Product Safety

PALFINGER products transport enormous masses – and in doing so have huge responsibility for the safety of all people involved. The aim of developing and applying safety functions is to make PALFINGER products the safest products in the market.

Durable Low-maintenance Products

PALFINGER products are designed for long useful lives. Innovation enables the products' smooth application at a low level of maintenance effort. This guarantees customer satisfaction and keeps warranty costs low.

Products for Sustainable Development

With its products and special solutions PALFINGER supports public transport, the recycling industry, and the generation of renewable resources – all of which are key areas for sustainable development and therefore also for markets with a promising future.

Ecological Product Design

PALFINGER products have the lowest possible dead weight compared to their lifting capacity and therefore leave a small ecological footprint. Special environmental indicators improve the Company's ecological performance.

Environmentally Sound Production

PALFINGER locations meet the highest requirements when it comes to environmentally friendly production. In 2008 a newly initiated project will compare the ecological performance of the individual locations and, if necessary, further improve it. Savings in this area will also have a positive economic impact.

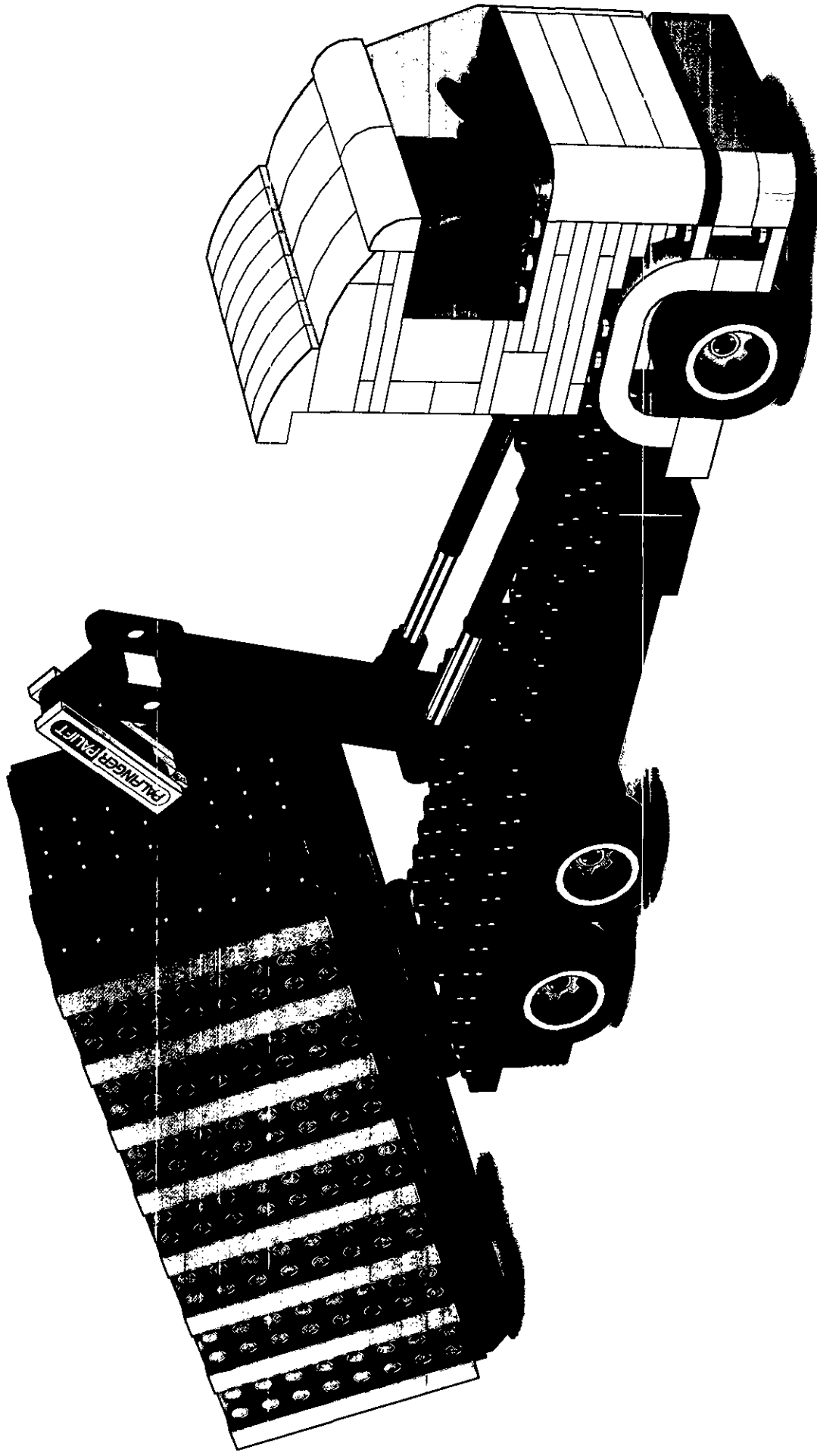

In 2007 PALINGER achieved the turnaround in its PALIFT division.

Performance of PALFINGER

How we will carry on building the PALFINGER brand

Marketing

SAIE 2007: Launch of the High Performance Crane Series

The kick-off for PALFINGER's new generation of cranes took place on 24 October 2007 at the SAIE in Bologna, Italy. The Company presented the first models of its innovative *High Performance* crane series at the leading Italian trade fair under the heading "We've made the best even better". Sales partners from all over the world came to the fair to witness the launch of this trend-setting product range first hand and to attend the subsequent gala event.

PALFINGER's product display at the SAIE fair – incidentally held in the home country of several of the Company's competitors – was accompanied by a wide range of marketing activities. Sales partners were, among other things, provided with marketing tools in a kit to be used for the product launch and target-group specific marketing. This package offers numerous marketing tools for both direct and indirect communications.

Introduction of the BISON TA Series at the BAUMA 2007

The new BISON TA series is regarded as a quantum leap in the development of aerial work platforms in the 3.5-tonne range. New standards were set with regard to design, functionality, comfort, and safety. PALFINGER's products were met with great interest by the visitors to the BAUMA – one of the world's largest trade fairs for the construction industry, held in Munich, Germany. This product launch was supported by marketing initiatives and dealer-support programmes.

75 years of PALFINGER: Anniversary Event Held in the Salzburg Arena

The 75th anniversary of PALFINGER was commemorated at a huge gala event held in the Salzburg Arena on 25 May 2007 where 1,500 guests from all over the world joined in congratulations. The international audience included sales partners, customers, suppliers, staff, as well as celebrities from the world of sports, politics, the economy, and society. The most prominent guests certainly were Alfred Gusenbauer, Federal Chancellor of Austria, Gabi Burgstaller, Provincial Governor of Salzburg, as well as Heinz Schaden, Mayor of Salzburg.

Corporate Identity/Corporate Design

The public image of a business must also be constantly modernised. In a huge corporate-design project substantial characteristics that are instantly recognisable, such as logos, product icons, and the layout of brochures, were carefully revised and/or updated.

New Image Video

Innovation is not just a mere slogan at PALFINGER and not something restricted to the Company's products. The concept of innovation was also fully integrated in the making of the new image video of PALFINGER. At its premiere at the 75th anniversary gala the video amazed the audience and got a standing ovation.

PALFINGER Workwear

In 2007 the introduction of uniform corporate workwear in all Austrian plants was successfully concluded and the relevant orders from international sales partners were filled as well. This uniform apparel in PALFINGER's design makes a visible contribution towards corporate identity.

Plant Visit PALtour

The new plant visit scheme aims at making a visit to one of PALFINGER's plants a great experience. The tours are to be given in an exciting and illustrative manner, meeting the needs of the respective interest groups.

Sports Sponsoring

Continuity pays off. The athletes Heinz Ollesch (heavyweight athletics), Egon Allgäuer and Jochen Hahn (both truck racing), who have been sponsored by PALFINGER for a long time, once again managed to impress their audiences with exceptional performances in their fields. In 2007 PALFINGER's sporting community welcomed Holger Brauwers, winner of the European Truck Trial Championship, as well as the Linz Black Wings – one of the best ice hockey teams in the Austrian league.

Social Sponsoring

PALFINGER caused quite a sensation when, at its 75th anniversary gala, a golden PK 74002 crane was auctioned off for charitable purposes. Kuhn-Ladetechnik GmbH, the Austrian general importer of PALFINGER, proved to be very generous in paying EUR 137,000 for this special model and giving the entire amount to the charity Huntington Hilfe Salzburg. Huntington's Chorea is a rare hereditary, degenerative disease that causes specific nerve cells in the brain to deteriorate. Signs and symptoms of the disorder typically develop between the ages of 30 and 45, and given the severe progression of the disease, an individual with Huntington's Chorea is expected to live only 15 years after the disease has been diagnosed.

The sports car excursion in aid of the Salzburg Children's Cancer Fund was the fourth event of this series and was once again heavily sponsored by PALFINGER. The car race has become one of the top charity events taking place in the province of Salzburg. The Fund was not only supported in organising the event but also received a donation of EUR 20,000.

The 2007 AMREF Marathon for the first time saw participation of more than 3,000 runners, and in wonderful weather thousands of spectators lined the streets to cheer and applaud the athletes. Since its foundation in Austria in 1992, PALFINGER has been supporting the work of the African Medical and Research Foundation (AMREF). The running event is designed to promote the objectives of AMREF and raise the population's awareness of the Foundation's concerns.

The proceeds from the 2007 PALFINGER Christmas raffles amounting to EUR 10,000 were donated to the Special Olympics. In January 2008, the 3rd National Winter Games took place in Innsbruck in Austria, with the event being supported by PALFINGER through making available cranes and aerial work platforms.

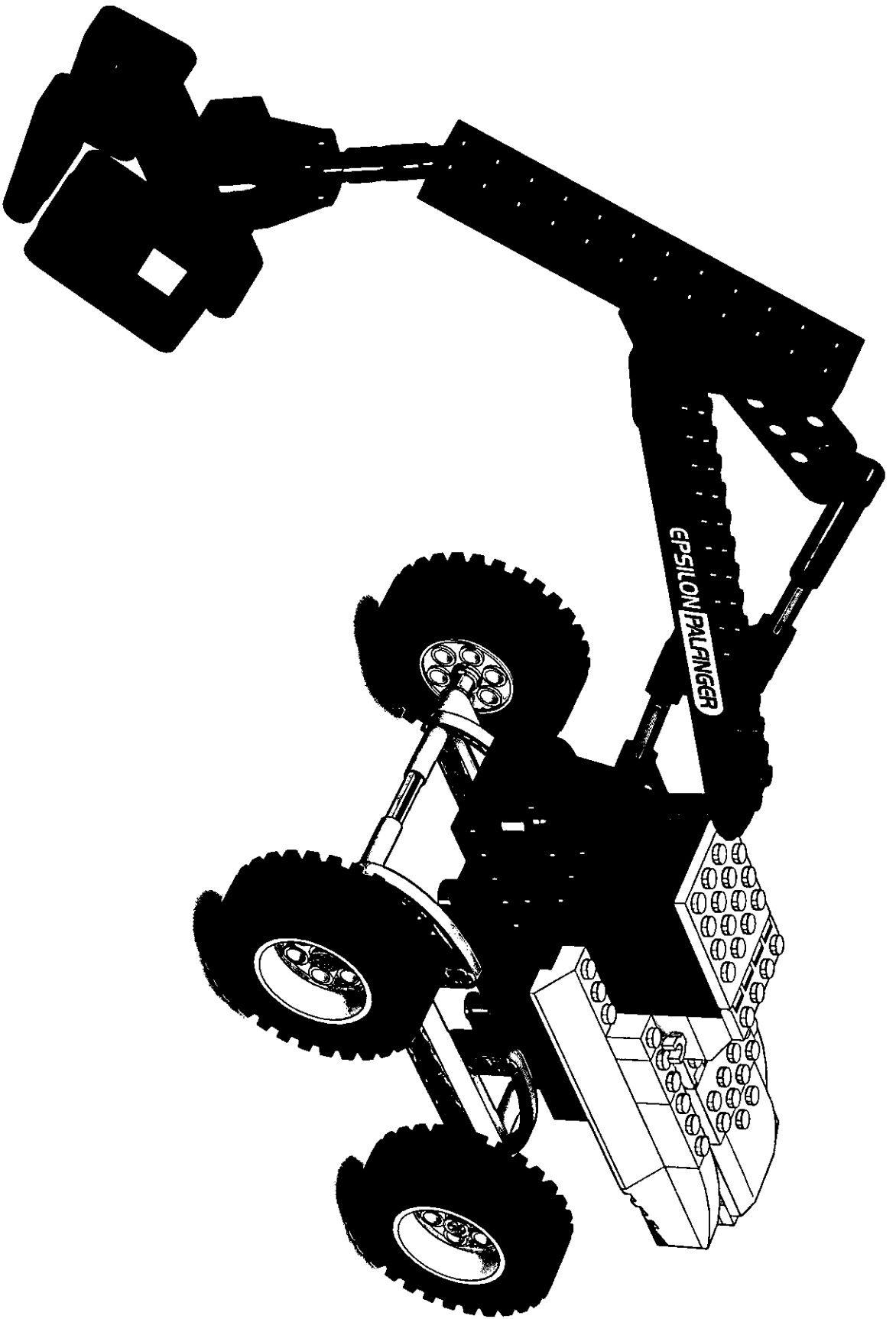

Higher-than-expected growth rates for EPSILON products were recorded in Russia, Australia, New Zealand, and South Africa.

Building blocks of success for each part of the world and for each product group

Performance by Region

Primary segmentation	Revenue TEUR	Revenue in %	EBIT TEUR	EBIT in %
EUROPE and REST of the WORLD	621,836	89.4%	97,793	98.1%
NORTH and SOUTH AMERICA	73,787	10.6%	1,845	1.9%

EUROPE and the REST of the WORLD

Europe remained the main contributor to the continuous growth in revenues and earnings in 2007. The ongoing positive economic development, infrastructure investments in Eastern Europe, and further market penetration by PALFINGER products supported PALFINGER's performance. Markets in Germany, Spain, France, and Scandinavia remained strong. The large attendance at the BAUMA fair in Munich in April 2007, which attracted record visitor numbers, was proof of the good state of the economy.

During the period under review very high growth rates were recorded particularly in Russia, as well as in Australia, New Zealand, and South Africa. The positive development in these countries was due in particular to the truck-mounted knuckle boom cranes and EPSILON products. In Great Britain CRAYLER sales increased despite the stagnating trend in the cranes area, and the TAIL LIFT area stabilised after the temporary market turbulence in 2006.

Revenue in the segment EUROPE and the REST of the WORLD rose by 21.5 percent, from EUR 511.9 million to EUR 621.8 million, while EBIT increased by 32.5 percent, from EUR 73.7 million to EUR 97.8 million. The EBIT margin improved to 15.7 percent as compared to 14.4 percent in the previous year.

Performance of the Business Divisions

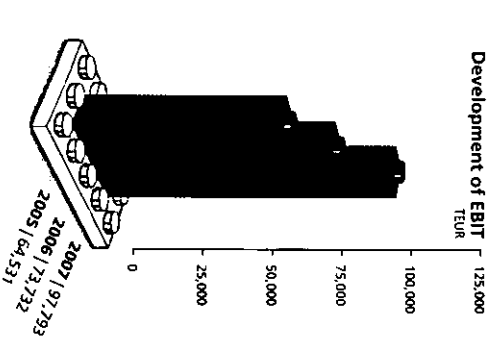
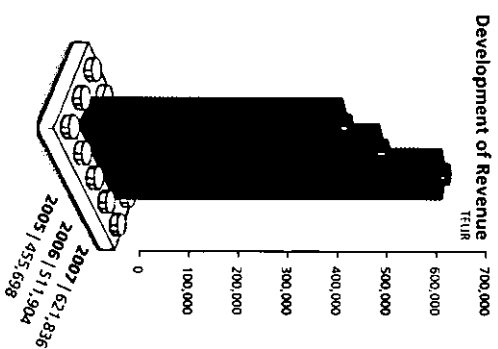

Share in the consolidated net profit for the year	in % of		2007		2006	
	Group		TEUR		TEUR	
External sales						
Depreciation, amortisation, and impairment		89.4%	621,836	511,904	13,043	13,043
EBIT		86.1%	13,463	13,043	73,732	73,732
Liabilities		98.1%	97,793	97,793	116,994	116,994
Assets		74.7%	174,338	174,338	347,645	347,645
Investment in property, plant, and equipment, and intangible assets		86.5%	457,081	457,081	19,885	19,885
EBIT margin		90.4%	77,313	77,313	15.7%	14.4%

	TEUR			
	Q1 2007	Q2 2007	Q3 2007	Q4 2007
Revenue	146,140	156,142	145,159	174,395
EBIT	23,878	26,003	21,168	26,744
EBIT margin	16.3%	16.7%	14.6%	15.3%

As the positive market development continued it was not possible to shorten delivery periods significantly in spite of measures initiated in the supplier, manufacturing, and assembly fields. The dealers manage to increasingly mitigate the end customers from the problem of delivery periods by means of consistent order management. While PALFINGER continues to adjust its own production capacities to the requirements, initiatives to increase the delivery capacities of the subcontractors while guaranteeing a high level of quality are underway. In terms of human resources the changed framework conditions created by the accession of Bulgaria and Romania to the European Union are reflected in the increased mobility of the staff there. This problem is taken into account by means of innovative human resource development approaches. The sustainable availability of qualified personnel at the right time and place is the central factor of success for the development of PALFINGER.

In the Asia & Pacific area the local market strategy pursued is advancing, with the current focus being on expanding the dealer and service network. Having established a distribution joint venture in India, the next steps are now taken in China and in other Southeast-Asian countries. During the first quarter 2007 the first hook loaders left the assembly plant in Shenzhen, China, but the 2007 output was still at a low level. The market experience gained in the course of the local supplier development was included in the value-creation strategy and prompted PALFINGER's decision to build up its own manufacturing capacities for components in Shenzhen.

NORTH and SOUTH AMERICA

In North America assembly capacities were stepped up in 2007. Crane assembly in Canada underwent layout changes and was expanded considerably. In the CRAYLER area, PALFINGER had started to build up local assembly units in the US in 2006, a process which was completed during the year under review. The continued weak exchange rate of the US dollar underlined the strategic significance of efforts to increase localisation in purchasing and assembly. In 2007 the US dollar also depreciated against the Canadian dollar, posing new challenges for the North American market. PALFINGER is making intensive efforts to exploit the potential for developing new areas of application for knuckle boom cranes such as, for instance, oil fields where at the moment the less versatile telescopic cranes are still used.

In the cranes area, PALFINGER succeeded in further increasing its order intake in Canada and even more so in Mexico. However, the bigger US American market suffered a significant decline as a consequence of the turbulence in the real estate market. In the CRAYLER business, the market decline made the planned intensification of the market strategy difficult.

In South America the output achieved on the basis of the projects initiated in 2006 at all stages of the value-creation chain was increased. Another focus of attention was the stabilisation of the process chain. In the key account area, PALFINGER succeeded in positioning itself as a preferred supplier in 2007. The cooperation with SENNEBOGEN in the telescopic crane area was well received by the market but is impaired by the long delivery periods for central construction components. Following the organisational and conceptual optimisation of the value-creation structure, a capacity enhancement and rationalisation investment programme was also launched in Brazil during the fourth quarter 2007.

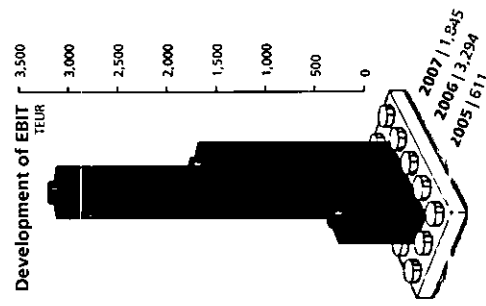
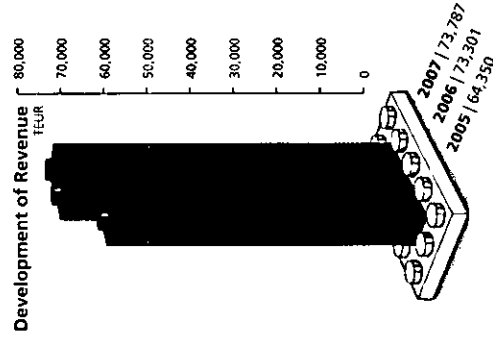

Share in the consolidated net profit for the year	in % of Group		2006	
	2007	2006	TEUR	TEUR
External sales	10.6%	73,787	73,301	73,301
Depreciation, amortisation, and impairment	13.9%	2,175	2,057	2,057
EBIT	1.9%	1,845	3,294	3,294
Liabilities	25.3%	58,920	50,408	50,408
Assets	13.5%	71,233	61,721	61,721
Investment in property, plant, and equipment, and intangible assets	9.6%	8,208	2,664	2,664
EBIT margin	2.5%		4.4%	

Performance of the Business Divisions

TEUR	Q1 2007	Q2 2007	Q3 2007	Q4 2007
Revenue	16,256	22,054	18,857	16,620
EBIT	91	1,021	1,187	(454)
EBIT margin	0.6%	4.6%	6.3%	(2.7%)

Revenue in the NORTH and SOUTH AMERICA segment rose slightly from EUR 73.3 million to EUR 73.8 million, while EBIT came to EUR 1.8 million, up from EUR 3.3 million, thus reflecting the currently difficult situation in the US market.

Performance by Product Group

Secondary segmentation	Revenue	Revenue	EBIT	EBIT
	TEUR	in %	TEUR	in %
CRANES	510,140	73.3%	99,721	100.1%
HYDRAULIC SYSTEMS and SERVICES	185,483	26.7%	(83)	(0.1%)

CRANES

The CRANES segment was characterised by excellent market development, in particular in Europe, which is reflected in the uninterrupted rise in order volume. Due to this growth, it was not possible for PALFINGER to shorten delivery times significantly in the course of 2007 as compared to the beginning of the year despite the fact that both capacity and productivity increased.

The definite trend towards higher performance classes and higher quality fittings when replacement investments occur continued in the area of knuckle boom cranes. Due to temporary process inefficiencies in the course of the expansion of capacities, this development was only partly reflected in an improvement of the EBIT margin.

In October the new *High Performance* crane series had its world premiere on the occasion of the SAIE trade show in Bologna. This series is a result of the crane development efforts of recent years and will contribute to the reduction of life-cycle costs. PALFINGER expects that the presentation of the new series to the market will be an additional boost of the dynamics of the positive performance in Europe and South America. It is planned to replace all of the 80 former PALFINGER crane models with the new crane generation within the next three years.

In the area of telescopic cranes for the South American market, the first PALFINGER SENNEBOGEN products were delivered and received a very promising market response. In the second half 2007 the emphasis was on additional cost-optimisation programmes and on a sustainable improvement of output figures.

e demand for cranes – the main product

PALFINGER – continued to be strong.

2007 PALFINGER implemented measures

shorten delivery times and introduced the

w High Performance crane series.

The EPSILON division also benefited from the favourable market conditions. PALFINGER succeeded in gaining additional market shares and became the global market leader in timber and recycling cranes during the period under review. Order intake in the traditional on-road area was increased above average, in particular in Austria, Germany, France, and Russia. The off-road business, which PALFINGER had added to its product range in the second half 2006, achieved its first sales successes during the reporting year. The strong demand and the tight materials supply situation also led to longer delivery times in the EPSILON division, a development which PALFINGER counteracted with an intensive expansion of assembly capacities in the course of 2007.

Share in the consolidated net profit for the year	in % of Group		2007		2006					
			TEUR	TEUR	TEUR	TEUR				
External sales	73.3%		510,140		413,180					
EBIT	100.1%		99,721		84,384					
Assets	59.7%		315,146		243,473					
Investment in property, plant, and equipment, and intangible assets	53.3%		45,587		16,972					
EBIT margin			19.5%		20.4%					
			Q1 2007		Q2 2007		Q3 2007		Q4 2007	
Revenues			117,941	130,526	119,777	141,896				
EBIT			24,213	26,206	22,325	26,977				
EBIT margin			20.5%	20.1%	18.6%	19.0%				

Revenue of the CRANES segment rose by 23.5 percent in 2007, from EUR 413.2 million to EUR 510.1 million. EBIT increased by 18.2 percent, from EUR 84.4 million to EUR 99.7 million.

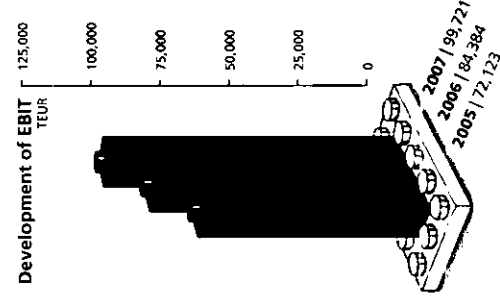
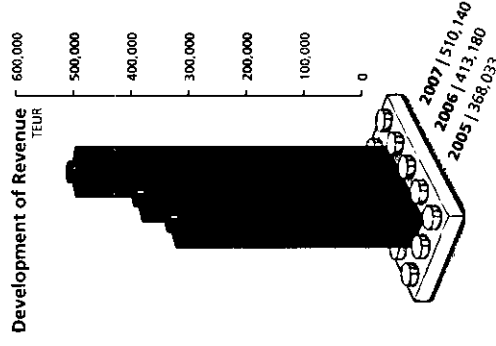

Performance of the Business Divisions

HYDRAULIC SYSTEMS and SERVICES

In the HYDRAULIC SYSTEMS and SERVICES segment revenue rose from EUR 172.0 million to EUR 185.5 million, corresponding to an increase of 7.8 percent. EBIT of EUR – 0.1 million, up from EUR – 7.4 million in 2006, was the best annual result ever achieved in this segment so far and shows that the consistent market strategy and the implementation of measures to increase profitability in the individual divisions have been successful.

	in % of			
	Group			
Share in the consolidated net profit for the year	2007	2006	2007	2006
	TEUR			
External sales	26.7%	185,483	172,025	
EBIT	(0.1%)	(83)	(7,358)	
Assets	40.3%	213,168	165,893	
Investment in property, plant, and equipment, and intangible assets	46.7%	39,934	5,577	
EBIT margin		(0.1%)		(4.2%)
	TEUR			
	Q1 2007	Q2 2007	Q3 2007	Q4 2007
Revenue	44,455	47,670	44,239	49,119
EBIT	(244)	818	30	(687)
EBIT margin	(0.5%)	1.7%	0.1%	(1.4%)

The PALFT division managed to stabilise processes and to consistently increase output and quality in 2007. The further optimisation of costs was advanced by the Intensification of the local purchasing organisation and by new supplier development programmes. Measures aimed at increasing efficiency at all stages of the value-creation chain proved successful from the second quarter 2007 onwards. Turnaround was achieved in the third quarter on the basis of the European market. After having established local assembly services in China, the development of a local supplier network and component production facilities of PALFINGER have been advanced since the third quarter 2007 in order to be able to efficiently utilise the potential of the Asian market.

The development of TAIL LIFT products in the first quarters of 2007 proved to be difficult but the acquisition of MBB in the fourth quarter gave them new potential for success. After a difficult year for RATCLIFF in 2006 the division reported an increase in order intake due to annual framework agreements in the first quarter 2007. This development did not continue in the second and third quarters, the reward for the consistent product and market development came only in the fourth quarter.

The PALGATE Continental European tail lift will be merged into MBB tail lifts, a process which is scheduled to be completed by the second quarter 2008. Assembly services will be phased out gradually in Austria, and the human resources released will be redeployed for capacity expansion in the crane area at the production site in Lengau. The headquarters of MBB in Germany are to become a centre of excellence for Continental European tail lifts in the future.

The RAILWAY business was influenced by the positive performance of the European railway market. In the 2007 financial year, existing orders were filled successfully and new projects were initiated. This led to a significant increase in revenue as well as a gratifying EBIT development.

In 2007 the order intake in the CRAYLER product area in Europe was satisfactory, mainly because of the strong market position in Germany. The development was similarly positive in Great Britain. In North America, however, efforts were hampered by the decline of the market caused by the US real estate crisis. The relocation of assembly facilities was completed in the first half of 2007 and was one of the factors why earnings stayed at the same level. Measures to step up local purchasing and on-site adjustments to development activities are also expected to have a positive impact on the results in the future.

In the BISON division the current investment programme was completed. Materials supply was stabilised and assembly was optimised due to the concentration of assembly services at the location in Löbau and due to process improvements. These measures led to a significant increase in output figures and a significant improvement of earnings, which made it possible to achieve turnaround. Starting from the second quarter 2007, BISON also reported a positive order intake, partly thanks to the favourable economic environment in Germany. In 2008 the electronic control system will be completed and the planned serial production of the new TA series will start. This will enable the exploitation of additional efficiency-increasing potential at all stages of the value-creation chain, which will further contribute to a positive result.

The SERVICES segment was marked by the constant expansion of PALFINGER's dealer and service network. The product-oriented services organisation has already been implemented in Europe and more training capacities have been introduced. In North and South America the further expansion of the service network for the entire region was continued and an exchange of experience intensified. After the acquisition of MBB, PALFINGER now has around 400 additional service centres in North America.

Individualised service features support dealers and customers on site. The new *High Performance* crane series will make the serviceability of the products even easier. In addition, projects at the interface to the truck trailer industry, the development of analysis tools in the electronics area, guaranteed spare parts supply, and targeted staff training reflected the intensive service approach at PALFINGER. Revenue and earnings in this area were further improved in 2007.

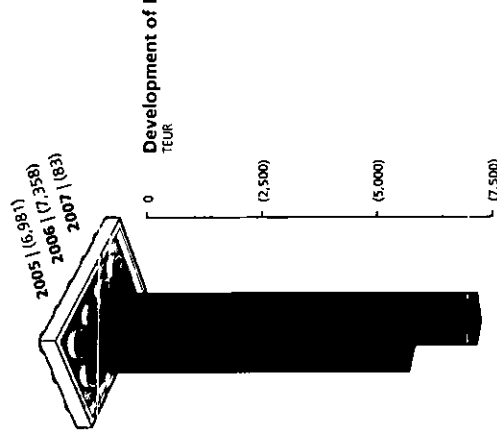
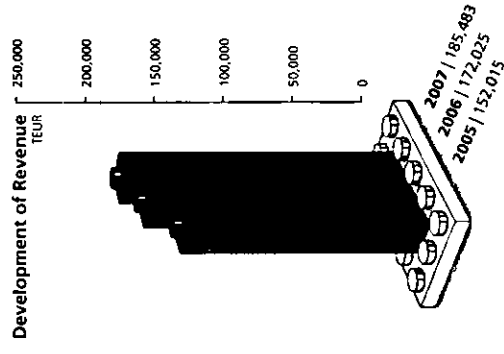

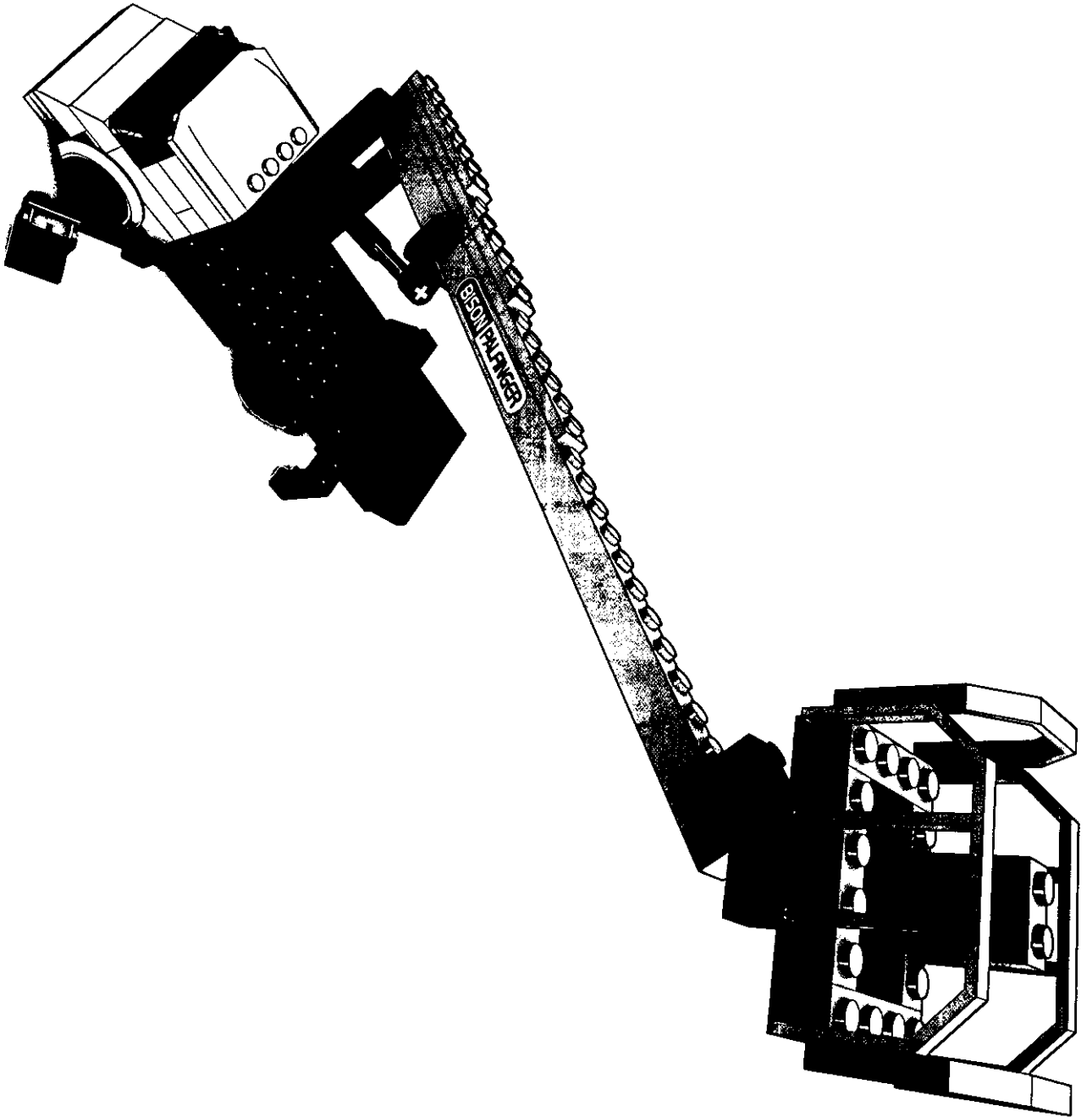

The new BISON TA series sets new standards in terms of design, functionality, comfort, and safety in the aerial work platform segment up to 3,5 tonnes.

What we will build on in the future

With the take-over of the German company MBB LIFTSYSTEMS AG, one of the world's leading suppliers of tail lifts, in the fourth quarter 2007, PALFINGER took another important step towards the fulfilment of its internationalisation and diversification strategy. MBB is going to be part of the TAIL LIFT division, thus giving greater weight to HYDRAULIC SYSTEMS. As a result of this take-over Group revenue will rise by narrowly 10 percent.

Business development in the 2008 financial year will furthermore, to a large extent, be characterised by the implementation of the investment programme currently underway, aiming at raising capacities while at the same time maintaining and enhancing quality. It will facilitate a further increase in output by the end of 2008. The second investment programme – adopted in the third quarter 2007 – will entail a further expansion of production facilities by 2010. At the same time increasing cost efficiency will be pushed in all areas and the lean initiatives expanded to all corporate divisions.

Moreover, PALFINGER will on the one hand have to secure the availability of the required resources, including a stable materials supply. In this context the Company expects further price increases, in particular of raw materials. On the other hand, the availability of skilled labour at the production facilities continues to be a big challenge for the necessary increase in output. In this connection PALFINGER will embark on special employee retention programmes in order to secure existing capacities over the long term, while at the same time attracting new employees.

For the years to come PALFINGER proceeds from the assumption of a continued strong market environment, with partially weaker markets being compensated by the growing markets in Eastern Europe. This is the basis on which, from 2008 onwards, the Company will be placing its strategic focus increasingly on future projects for expanding its areas and product divisions.

Management expects that a positive development of the market in 2008 will support and ensure the profitable growth strategy.

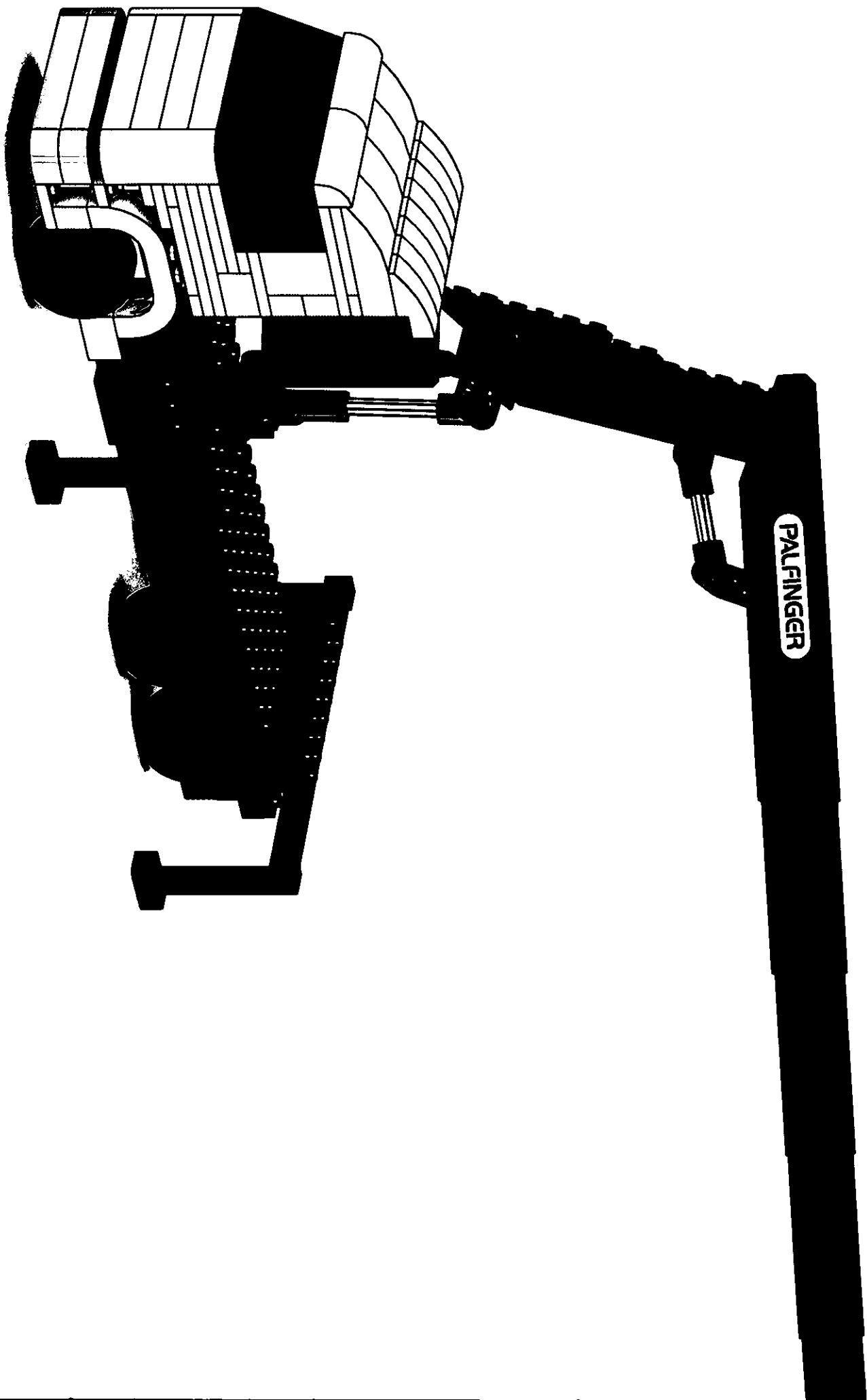

PALFINGER

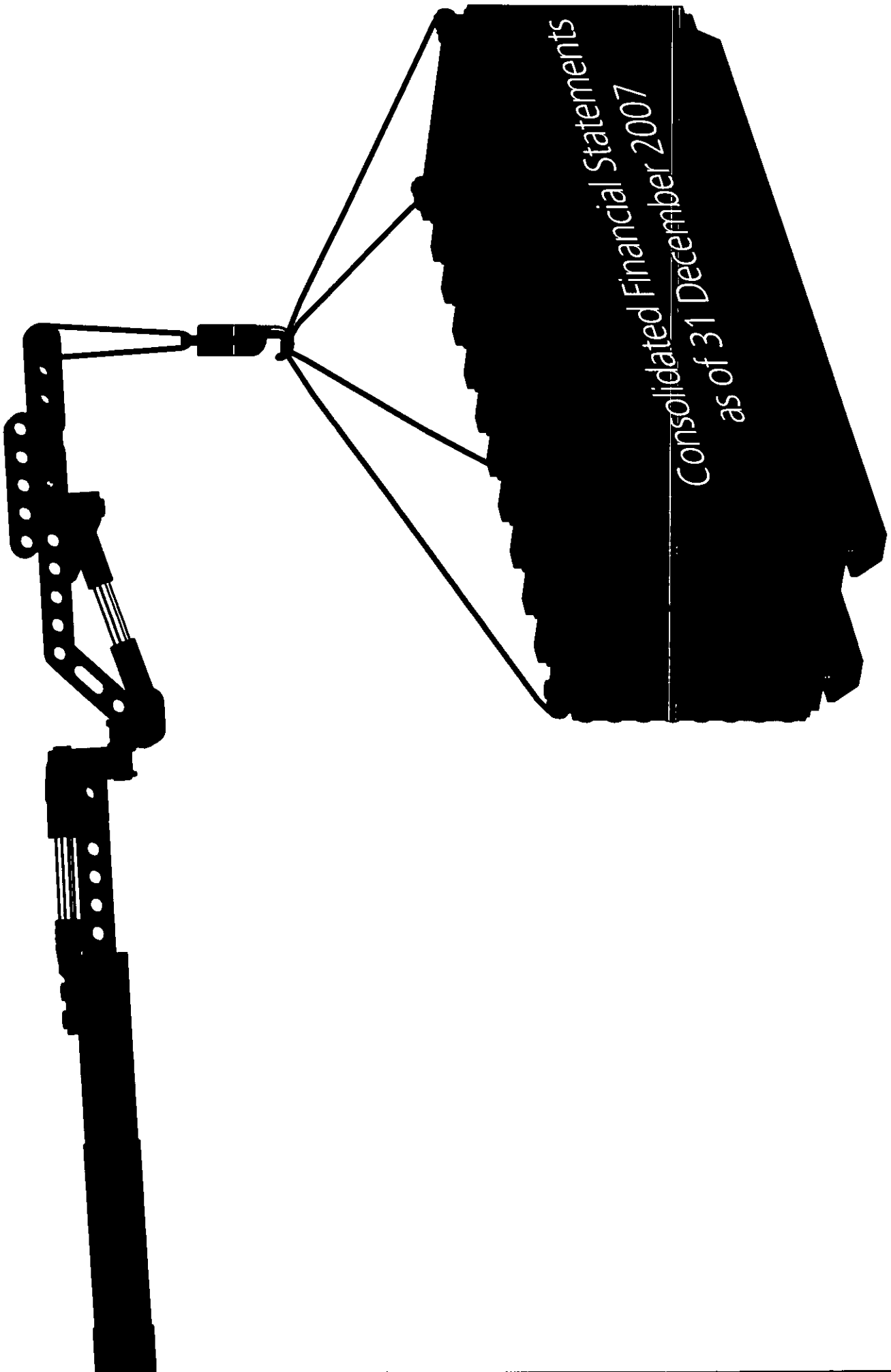

Consolidated Financial Statements
as of 31 December 2007

Consolidated Balance Sheet

TEUR	Note	31 Dec 2007	31 Dec 2006
ASSETS			
Non-current assets			
Intangible assets	1	54,609	31,420
Property, plant, and equipment	2	149,990	98,130
Investments in associated companies	3	11,951	8,054
Deferred tax assets	4	19,663	14,043
Other non-current assets	5	2,732	2,942
		238,945	154,589
Current assets			
Inventories	6	151,894	114,249
Receivables and other current assets	7	133,112	104,004
Current tax receivables		1,121	5,988
Cash and cash equivalents	8	2,559	30,536
		288,686	254,777
Non-current assets held for sale	9	683	0
		289,369	254,777
Total assets		528,314	409,366
EQUITY AND LIABILITIES			
Equity			
Share capital	10	37,135	18,568
Additional paid-in capital	11	35,190	53,757
Retained earnings	12	221,607	171,034
Revaluation reserve	13	(112)	0
Valuation reserves pursuant to IAS 39	14	519	776
Foreign currency translation reserve	15	(4,923)	(6,053)
		289,416	238,082
Minority interests	16	5,640	3,882
		295,056	241,964
Non-current liabilities			
Non-current financial liabilities	17	38,315	31,566
Non-current provisions	18	21,103	15,426
Deferred tax liabilities	4	5,668	259
Other non-current liabilities	19	1,176	4,174
		66,262	51,425
Current liabilities			
Current financial liabilities	20	43,598	15,241
Current provisions	21	14,063	16,402
Current tax liabilities		10,059	8,133
Other current liabilities	22	99,276	76,201
		166,996	115,977
Total equity and liabilities		528,314	409,366

	Note	Jan-Dec 2007	Jan-Dec 2006
TEUR			
Revenue	23	695,623	585,205
Changes in inventories and own work capitalised	24	11,302	15,158
Other operating income	25	11,738	12,643
Materials and external services	26	(371,047)	(316,363)
Staff costs	27	(141,183)	(122,887)
Depreciation, amortisation, and impairment expenses	28	(15,638)	(15,100)
Other operating expenses	29	(91,157)	(81,630)
Earnings before interest and taxes (EBIT)		99,638	77,026
Income from associated companies	30	5,755	2,106
Interest and other financial expenses	31	(3,001)	(3,549)
Net financial result		2,754	(1,443)
Profit before income tax		102,392	75,583
Income tax expense	32	(24,324)	(15,904)
Profit after income tax		78,068	59,679
attributable to			
Minority interests		4,090	3,076
Shareholders of PALFINGER AG (consolidated net profit for the period)		73,978	56,603
EUR			
Earnings per share (undiluted and diluted) ¹⁾	12	2.09	1.60
Dividend per share ²⁾	12	0.70 ¹⁾	0.55

¹⁾ Proposal of the Management Board to the Supervisory Board for presentation to the Annual General Meeting for resolution.

²⁾ Previous year's figures were converted pursuant to the stock split.

Consolidated Cash Flow Statement

	TEUR	
	Jan-Dec 2007	Jan-Dec 2006
Profit before income tax	102,392	75,583
+/- Write-downs and write-ups of non-current assets	13,905	15,100
-/+ Gains/losses on the disposal of non-current assets	149	(57)
-/+ Income from associated companies	(5,755)	(2,106)
+ Expense for stock option programme	57	102
-/+ Other non-cash income/expenses	(808)	(39)
-/+ Increase/decrease in current assets	(47,323)	(23,702)
+/- Increase/decrease in provisions	(13,076)	2,119
+/- Increase/decrease in liabilities	24,080	9,867
Cash generated from operations	73,621	76,867
+ Dividends received from associated companies	1,564	2,043
- Income tax paid	(22,160)	(19,431)
Cash flows from operating activities	53,025	59,479
+ Cash receipts from the sale of intangible assets and property, plant, and equipment	1,655	801
- Cash payments for the acquisition of intangible assets and property, plant, and equipment	(62,308)	(22,549)
- Cash payments for the acquisition of subsidiaries net of cash acquired	(24,674)	(70)
- Funds of wound-up companies	(78)	0
+ Cash receipts from the sale of long-term and short-term securities	5,242	0
-/+ Increase/decrease in other non-current assets	176	2,899
Cash flows for investing activities	(79,987)	(18,919)
- Dividends to shareholders of PALLINGER AG	(19,409)	(15,862)
- Dividends to minority shareholders	(2,275)	(2,800)
+ Sale of treasury stock in the course of the stock option programme	394	239
+/- Increase/decrease in non-current liabilities	1,332	16,184
+/- Increase/decrease in current financial liabilities	19,000	(9,440)
+/- Other changes in equity	3	101
Cash flows for financing activities	(955)	(11,578)
Total cash flows	(27,917)	28,982
Funds		
At 1 January	30,536	1,554
Effects of exchange rate fluctuations	(60)	0
At 31 December	2,559	30,536

Consolidated Statement of Changes in Equity

Equity attributable to the shareholders of PALFINGER AG

TEUR	Share capital	Additional paid-in capital	Retained earnings	Revaluation reserve	Reserves pursuant to IAS 39	Foreign currency translation reserve	Total	Minority interests	Equity
At 1 Jan 2006	18,568	53,757	126,647	0	(1,955)	(4,495)	192,522	5,477	197,999
Total recognised income and expense for the period									
Income and expense directly recognised in equity									
Valuation gains/(losses) from cash flow hedges	0	0	0	0	2,731	0	2,731	0	2,731
Stock options acc. to IFRS 2	0	0	102	0	0	0	102	0	102
Actuarial gains/(losses) acc. to IAS 19	0	0	203	0	0	0	203	0	203
Other changes	0	0	3,102	0	0	(1,558)	1,544	(1,871)	(327)
Profit after income tax	0	0	3,407	0	2,731	(1,558)	4,580	(1,871)	2,709
	0	0	56,603	0	0	0	56,603	3,076	59,679
	0	0	60,010	0	2,731	(1,558)	61,183	1,205	62,388
Transactions with shareholders									
Dividends	0	0	(15,862)	0	0	0	(15,862)	(2,800)	(18,662)
Other changes	0	0	239	0	0	0	239	0	239
At 31 Dec 2006	18,568	53,757	171,034	0	776	(6,053)	238,082	3,882	241,964
At 1 Jan 2007	18,568	53,757	171,034	0	776	(6,053)	238,082	3,882	241,964
Total recognised income and expense for the period									
Income and expense directly recognised in equity									
Valuation gains/(losses) from cash flow hedges	0	0	0	0	(257)	0	(257)	0	(257)
Stock options acc. to IFRS 2	0	0	57	0	0	0	57	0	57
Actuarial gains/(losses) acc. to IAS 19	0	0	(2,183)	0	0	0	(2,183)	0	(2,183)
Other changes	0	0	(2,269)	(112)	0	1,130	(1,251)	0	(1,251)
Profit after income tax	0	0	(4,395)	(112)	(257)	1,130	(3,634)	0	(3,634)
	0	0	73,978	0	0	0	73,978	4,090	78,068
	0	0	69,583	(112)	(257)	1,130	70,344	4,090	74,434
Transactions with shareholders									
Dividends	0	0	(19,409)	0	0	0	(19,409)	(2,275)	(21,684)
Capital increase	18,567	(18,567)	0	0	0	0	0	0	0
Other changes	0	0	399	0	0	0	399	(57)	342
At 31 Dec 2007	37,135	35,190	221,607	(112)	519	(4,923)	289,416	5,640	295,056

Notes to the Consolidated Financial Statements 2007**General**

PALFINGER AG is a public listed company headquartered in 5101 Berghelm, Salzburg, Austria, Franz-Wolfram-Scherer-Strasse 24, whose main business activity is the provision of innovative hydraulic lifting, loading, and handling solutions at each interface of the transport chain.

The consolidated financial statements of PALFINGER AG as of 31 December 2007 were prepared in line with the International Financial Reporting Standards (IFRS) issued by the International Accounting Standards Board (IASB) and the interpretations of the International Financial Reporting Interpretations Committee (IFRIC) to be applied within the European Union (EU). IFRS and IFRIC interpretations whose application is mandatory for financial years starting on or after 1 January 2008 were not applied ahead of time.

As these consolidated financial statements meet the criteria laid down in sec. 245a of the Austrian Business Code (UGB) the Company is not obligated to prepare financial statements according to the provisions of the Code.

These consolidated financial statements were prepared as of the reporting date of the parent company. The financial year corresponds to the calendar year. The financial statements of the individual Austrian and foreign companies included in the consolidated financial statements 2007 were prepared as of the reporting date of the consolidated financial statements.

Uniform accounting and valuation criteria were applied within the Group. The consolidated financial statements were prepared on the assumption that the Company will continue as a going concern. For the sake of a clearer presentation, items were aggregated for the purposes of the consolidated balance sheet, the consolidated income statement, the consolidated cash flow statement, and the consolidated statement on changes in equity. The same items were then listed and explained separately in the notes, following the principle of materiality. When preparing these consolidated financial statements the principle of recognition at amortised cost was applied and revaluations of certain financial instruments were made.

The consolidated balance sheet was structured according to IAS 1, separating current from non-current assets and liabilities. The consolidated income statement was prepared according to the nature of expense method.

For the sake of clarity and comparability, all figures in the consolidated financial statements are, in principle, expressed in thousands of euros ("TEUR"). Minimal arithmetic differences may arise from the application of commercial rounding to individual items and percentages.

The consolidated financial statements 2007 and the individual financial statements for 2007 were published in accordance with statutory requirements and are available from PALFINGER AG on request at any time. The consolidated financial statements of PALFINGER AG as of 31 December 2007 were released for publication on 11 February 2008 by the Group's Management Board.

Consolidation Principles

Scope of Consolidation

PALFINGER AG is the ultimate parent entity that prepares consolidated financial statements. The consolidated financial statements comprise the financial statements of PALFINGER AG and the financial statements of the companies controlled by PALFINGER AG as of 31 December of each year. Control is defined as the power to govern the financial and operating policies of an entity so as to obtain benefits from its activities.

Associated companies were included according to the equity method. An associated company is a company on which PALFINGER AG may exercise significant influence by participating in its financial and operating policy decisions but over which it has no control or joint control.

As of 31 December 2007, the scope of consolidation, including PALFINGER AG as the parent company, comprised 26 fully consolidated companies and four companies consolidated using the equity method, whose names are disclosed in the statement of investments.

Notes to the Consolidated Financial Statements 2007

Company, headquarters

Fully consolidated companies

	Controlling company ¹⁾	Direct interest ²⁾	Indirect interest ³⁾	Curr. ⁴⁾	Equity 31 Dec 2007	Profit for the period Jan-Dec 2007
		percent	percent		Curr. in thousand	Curr. in thousand
Bison Palfinger GmbH, Löbau (DE)	PEU	100.00	99.97	EUR	7,806	(1,225)
EPSILON Kran GmbH, Salzburg (AT)	PEU	65.00	64.98	EUR	14,967	11,610
Financière Palfinger S.A.S., Caussade (FR)	PEU	100.00	99.97	EUR	(5,803)	45
Guima France S.A.S., Caussade (FR)	GP	100.00	99.97	EUR	916	1,140
Guima Palfinger S.A.S., Caussade (FR)	PEU	100.00	99.97	EUR	5,705	653
INTERLIFT Inc., Cerritos (US)						
(Initial consolidation: 31 December 2007)	MBB	100.00	99.97	USD	1,465	-
Madal Palfinger S.A., Caxias do Sul (BR)	PSB	99.00	99.00	BRL	19,908	38
MBB HUBFIX s.r.o., Bratislava (SK)						
(Initial consolidation: 31 December 2007)	MBB	100.00	99.97	SKK	1,613	-
MBB INTER S.A.S., Sillery en Gouffern (FR)						
(Initial consolidation: 31 December 2007)	MBB	100.00	99.97	EUR	(8,254)	-
MBB INTERLIFT N.V., Erembodegem (BE)						
(Initial consolidation: 31 December 2007)	MBB	100.00	99.97	EUR	(124)	-
MBB LIFTSYSTEMS AG, Ganderkesee (DE)						
(Initial consolidation: 31 December 2007)	PEU	100.00	99.97	EUR	3,628	-
MBB LIFTSYSTEMS Ltd., Cobham (UK)						
(Initial consolidation: 31 December 2007)	MBB	100.00	99.97	GBP	(952)	-
Palfinger Asia Pacific Pte. Ltd., Singapore (SG)	PSB	100.00	100.00	SGD	(275)	(369)
Palfinger Europe GmbH, Salzburg (AT)	PSB	99.97	99.97	EUR	111,306	76,040
Palfinger GmbH, Airing (DE)	PEU/PSB	100.00	99.97	EUR	11,187	5,714
Palfinger Gru Idrrauliche s.r.l., Bolzano (IT)	PEU	100.00	99.97	EUR	2,684	1,810
Palfinger Inc., Niagara Falls (CA)	PSB	100.00	100.00	CAD	13,913	170
Palfinger Produktionstechnik Bulgaria EOOD, Cherven Brjag (BG)	PSB	100.00	100.00	BGN	60,986	3,694
Palfinger proizvodnja d.o.o., Maribor (SI)	PSB	100.00	100.00	EUR	11,622	(935)
Palfinger Service- und Beteiligungs-GmbH, Salzburg (AT)	PAG	100.00	100.00	EUR	130,739	62,454
Palfinger (Shenzhen) Co. Ltd., Shenzhen (CN)	PAP	100.00	100.00	CNY	4,416	(2,646)
Palfinger USA Inc., Tiffin (US)	PSB	100.00	100.00	USD	5,049	151
PIR metal d.o.o., Rijeka (HR)						
(Initial consolidation: 31 July 2007)	PSB	100.00	100.00	HRK	4,619	627
Ratcliff Palfinger Ltd., Welwyn Garden City (UK)	PEU	100.00	99.97	GBP	10,490	(1,117)
Tiffin Loader Crane Company, Tiffin (US)	PUSA	100.00	100.00	USD	1,121	(509)

Company, headquarters	Controlling company ¹⁾	Direct interest ²⁾	Indirect Interest ³⁾	Curr. ⁴⁾	Equity 31 Dec 2007	Profit for the period Jan-Dec 2007
Companies consolidated using the equity method						
Palfinger Argentina S.A., Buenos Aires (AR)	PEU	49.00	48.99	ARS	402	229
Palfinger France S.A., Étoile sur Rhône (FR)	PEU	49.00	48.99	EUR	20,138	5,725
Palfinger Southern Africa (Pty) Ltd., Edenvale (ZA)	PEU	33.33	33.32	ZAR	17,686	3,844
STEPA Farmkran Gesellschaft m.b.H., Elisabethen (AT)	PEU	45.00	44.99	EUR	3,303	1,407

¹⁾ Controlling company:

PAG = PALFINGER AG, Salzburg (AT)

PSB = Palfinger Service- und Beteiligungs-GmbH, Salzburg (AT)

PEU = Palfinger Europe GmbH, Salzburg (AT)

PUSA = Palfinger USA Inc., Tiffin (US)

PAP = Palfinger Asia Pacific Pte. Ltd., Singapore (SG)

MBB = MBB LIFTSYSTEMS AG, Ganderkesee (DE)

GP = Guima Palfinger S.A.S., Caussade (FR)

²⁾ from the point of view of the controlling company

³⁾ from the point of view of PALFINGER AG

⁴⁾ Curr. = local currency

Newly Founded Companies

On 14 September 2007 the PALFINGER Group entered into a distribution joint venture agreement with one of the leading automobile trading companies in India, Western Auto L.L.C. Dubai. Western Auto L.L.C. is part of the ETA-Ascon Group. The Dubai-based group currently generates revenues of around USD 4 billion, employing a staff of more than 40,000. The group operates in India in the construction, transport, real estate, and automotive business sectors. Star Palfinger Equipments India Pvt. Ltd. is currently in the start-up phase. The joint venture is to comprise import, marketing, distribution, and service, for the time being, for selected PALFINGER crane models.

Acquisitions

As of 19 September 2007 the take-over of the remaining 80 percent of the Croatian supplier PIR metal d.o.o. was finalised. The PALFINGER Group had held an interest of 20 percent in PIR metal d.o.o. starting with 2001. At the time of take-over the steel component manufacturer employed a staff of 95. PIR will contribute to a further optimisation of the value-creation chain at PALFINGER. In the course of the reorganisation of the plant, PIR metal d.o.o. is to be converted into a welding and processing location.

After the Austrian and German antitrust authorities approved the take-over of the MBB Group, which had been decided upon on 29 October 2007, the transaction was closed on 6 December 2007. The initial consolidation was made as of 31 December 2007 as no material changes were involved in using this date instead of the date of acquisition.

The MBB Group is one of the top-three players in the global market for tail lifts. The German company is headquartered in Ganderkesee near Bremen and maintains distribution subsidiaries in Great Britain, France, Belgium, and the Slovak Republic and another production site in the US.

With decades of experience in the development, production, and distribution of tail lifts, MBB offers a comprehensive range of technically mature products that are well established in the market. In the 2007 financial year, the MBB Group employed a staff of 260.

Within the PALFINGER Group, the MBB Group will be active in the secondary segment HYDRAULIC SYSTEMS and SERVICES as part of the TAIL LIFT division, thus giving stronger weight to this segment.

At the time of acquisition, the carrying amounts were reconciled with the estimated fair values for PIR metal d.o.o., Croatia, and for the MBB Group as follows:

TEUR	Carrying amount acc. to local law	Fair value adjustments	Fair value
Non-current assets			
Intangible assets	404	(335)	69
Property, plant, and equipment	4,204	(388)	3,816
Deferred tax assets	0	1,612	1,612
Other non-current assets	86	0	86
	4,694	889	5,583
Current assets			
Inventories	10,486	0	10,486
Receivables and other current assets	8,271	0	8,271
Current tax receivables	123	0	123
Cash and cash equivalents	845	0	845
	19,725	0	19,725
Non-current liabilities			
Non-current financial liabilities	(2,344)	0	(2,344)
Non-current provisions	(1,920)	(784)	(2,704)
Deferred tax liabilities	(15)	0	(15)
	(4,279)	(784)	(5,063)
Current liabilities			
Current financial liabilities	(9,358)	0	(9,358)
Current provisions	(523)	0	(523)
Current tax liabilities	(117)	0	(117)
Other current liabilities	(7,072)	0	(7,072)
	(17,070)	0	(17,070)
Net assets (100%)	3,070	105	3,175
Net assets acquired (PIR 80% and MBB 100%)	2,819	218	3,037

The purchase prices were allocated on the basis of the estimated fair values as follows:

TEUR	2007
Purchase price	24,780
Direct costs relating to the acquisition	739
Total purchase price	25,519
less net assets acquired	(3,037)
Goodwill	22,482

Notes to the Consolidated Financial Statements 2007

The goodwill accrued in the course of the acquisition basically reflects the value of the expected synergies for value creation in the Knuckle boom crane division due to the fact that staff has been taken over and in the TAIL LIFT division due to the future product developments.

Goodwill was calculated on the basis of the estimated fair values at the time of acquisition. As the fairness opinions are not yet available and the figures have been restated according to IFRS, the fair values and consequently also the goodwill in the consolidated financial statements for 2008 might still change. The implementation process of the IFRS valuation principles applied within the PALFINGER Group has not been fully completed yet.

If the transactions had been made with effect as of 1 January 2007, the consolidated net profit for the period of PALFINGER AG, taking into account the IFRS measurements as known to date, would have been as follows:

TEUR	Jan-Dec 2007 stated	Jan-Dec 2007 pro-forma
Revenue	695,623	757,726
Consolidated net profit for the period	73,978	75,107
Earnings per share in EUR	2.09	2.13

The purchase prices were paid from cash in hand and at bank so that the net cash outflow from the acquisitions was as follows:

TEUR	Jan-Dec 2007
Total purchase price	(25,519)
Cash and cash equivalents	845
Net cash outflow from acquisitions	(24,674)

Mergers

By means of the Merger Agreement of 14 May 2007, Palfinger Industrieanlagen GmbH was merged into PALFINGER AG as the absorbing company with retroactive effect as of 31 December 2006 for the sake of simplifying internal structures. Palfinger Consult AG was compensated for its five-percent minority interest in Palfinger Industrieanlagen GmbH by being granted shares of PALFINGER AG of corresponding value. The merger was registered in the Register of Companies on 25 July 2007.

Liquidations

Regio Cargo Transporttechnik GmbH was wound up with effect as of 10 December 2007.

Consolidation Method

Pursuant to IFRS 3, which is applied in combination with IAS 36 and IAS 38, all business combinations must be accounted for by applying the purchase method. Under this method the consolidation of investments is carried out at the acquisition date by offsetting the purchase price with the net assets of the acquired business measured at fair value. The subsidiaries' identifiable assets, liabilities, and contingent liabilities are recognised at their full fair values, irrespective of the extent of the minority interest. Intangible items must be recognised separately from goodwill if they are either separable from the entity or arise from statutory, contractual, or other legal rights. Any remaining differences on the asset side are capitalised as goodwill. If negative differential amounts arise, the measurements of the identifiable assets, liabilities, and contingent liabilities of the acquired business, and the calculation of the cost of the business combination are reassessed and the differences are then recognised in the income statement.

According to IFRS 3 in combination with IAS 36 the capitalised goodwill is no longer amortised on a straight-line basis. Instead, the goodwill recognised must be tested for impairment annually and whenever circumstances indicate that it might be impaired. If the carrying amount of a cash-generating unit to which goodwill has been allocated exceeds the recoverable amount of the unit, the impairment loss in the amount of the difference is allocated first to reduce the carrying amount of the goodwill allocated to the unit. Any additional impairment loss is then allocated to the other fixed assets of the unit on a pro rata basis.

The initial consolidation of companies included for the first time was performed at the time of acquisition, which was also the point in time when control over the Company's net assets and business activities was obtained. The results of subsidiaries sold or acquired during the year are included in the consolidated income statement effective from the date of acquisition or until the date of sale.

Earnings, assets, and liabilities of associated companies are included in the consolidated financial statements applying the equity method. Investments in associated companies are reported in the balance sheet at cost after adjustment to changes in the Group's share of net assets after acquisition and impairment losses. Losses exceeding the Group's investment in associated companies are not recognised.

If the acquisition costs for the Group's investment are higher than the fair values of the associated company's identifiable assets and liabilities at the acquisition date, the difference is recognised as goodwill. If the acquisition costs for the Group's investment are lower than the fair values of the identifiable assets and liabilities at the acquisition date, the difference is recognised in the income statement in the acquisition period.

For associated companies consolidated using the equity method, the same principles of equity consolidation apply as those that apply to fully consolidated companies.

Intra-group accounts receivable and payable, income and expenses, including inter-company profits and losses are eliminated provided that they are material. Pursuant to IAS 12 deferred tax assets or liabilities are recognised for temporary differences arising from consolidation.

Shares of minority shareholders are reported in the amount of the fair values of the recognised assets and liabilities attributable to the minority interest.

Currency Translation within the Group

The consolidated financial statements are prepared in euros, the functional currency of PALFINGER AG.

Financial statements of Group companies reporting in foreign currencies are translated in accordance with the functional currency concept. The balance sheet items are converted using the middle rate at the balance sheet date. The income statement items of the consolidated foreign companies are converted using average rates for the period. Differences arising from the currency conversion of the pro rata equity are recognised directly in equity. In the event of the deconsolidation of a foreign company, these exchange rate differences are recognised in the income statement.

Exchange rate differences attributable to minority interests are offset against the interests of other shareholders.

Goodwill arising from the acquisition of foreign subsidiaries is allocated to the acquired company and translated at the respective middle rate at the balance sheet date.

The following exchange rates are of particular importance for the consolidated financial statements:

1 euro equals	Exchange rate as of	Exchange rate as of	Average exchange rate	Average exchange rate
	31 Dec 2007	31 Dec 2006	Jan-Dec 2007	Jan-Dec 2006
BGN	1.9572	1.9595	1.9576	1.9581
BRL	2.6081	2.8184	2.6739	2.7464
CAD	1.4451	1.5387	1.4726	1.4236
GBP	0.7374	0.6738	0.6862	0.6825
USD	1.4724	1.3198	1.3750	1.2558

The functional currency of Palfinger proizvodnja d.o.o., Slovenia, was changed from SIT to EUR as of 1 January 2007. The differences from currency translation accrued up to that date, which amounted to TEUR – 570, will be carried forward until the company is deconsolidated.

The effects of exchange rate movements on the calculation of the balance sheet items of the consolidated subsidiaries result in a change in equity of about TEUR 1,130 (previous year: TEUR – 1,558) booked through the balance sheet. This figure is reported under foreign currency translation reserve in the statement of changes in equity.

Accounting and Valuation Principles

Intangible Assets

Purchased intangible assets are capitalised at acquisition cost. Internally generated intangible assets are capitalised at manufacturing cost if the preconditions set out in IAS 38 regarding the capitalisation of internally generated intangible assets are satisfied.

Intangible assets are subject to amortisation over their relevant useful lives. With the exception of goodwill and intangible assets of indeterminable useful lives, amortisation is performed on a straight-line basis over a timeframe between two and ten years. Customer relationships capitalised as part of corporate acquisitions are amortised over a useful life of between five and ten years.

Impairments are recognised in the year in which the event giving rise to the impairment occurs. If the reasons for the impairment cease to exist corresponding write-ups are performed until the level of amortised cost is reached.

If there are no longer reasons for extraordinary write-downs, the relevant write-ups are made.

Goodwill

According to IFRS 3 goodwill is no longer amortised but is instead subject to an impairment test, which is to be carried out annually as well as whenever there are indications that value impairment has occurred.

In order to perform impairment tests, goodwill is allocated to cash-generating units. The essential standard applied for determining whether a unit qualifies as a cash-generating unit is the assessment of its technical and commercial independence in the generation of income. The impairment test of the cash-generating unit is carried out by comparing the amortised carrying amount (including the allocated goodwill) to the higher of either the net realisable value or the value in use. The value in use is calculated as the present value of relevant cash in- and outflows on the basis of the data obtained from the internal medium-term corporate planning.

Notes to the Consolidated Financial Statements 2007

The discount rate is derived from the weighted cost of capital of the Company. If the calculated amount is less than the carrying amount, the impairment loss in the amount of the difference is allocated first to reduce the carrying amount of the goodwill. Any additional impairment loss is then to be allocated to the remaining assets of the cash-generating unit in proportion to their carrying amounts.

According to IFRS 3 goodwill once written down for impairment can no longer be recovered.

Research and Development

Research expenses are reported in the income statement when incurred.

Development expenses made with a view to a significant further development of a product or a process are capitalised if the product or process is feasible both from a technological and commercial point of view, the development is marketable, the expenses can be measured reliably, and the PALFINGER Group has sufficient resources to complete the development project. All other development expenses are entered in the income statement immediately.

Capitalised development expenses of closed projects are reported at cost less accumulated amortisation. As long as a development project is not yet completed, an impairment test of the capitalised amounts accrued is carried out annually or more frequently if circumstances indicate that an impairment loss might have occurred.

In the 2007 financial year no development expenses were capitalised within the PALFINGER Group. The expenses for research and development for the 2007 financial year amounted to around TEUR 13,692 (previous year: TEUR 12,279). This corresponds to 2.0 percent (previous year: 2.1 percent) of the Group's total revenue.

Property, Plant, and Equipment

Property, plant, and equipment are reported at cost, adjusted for straight-line depreciation. Besides direct costs, production costs also contain appropriate proportions of materials and manufacturing overhead costs. General administrative expenses as well as interest on borrowings are not capitalised.

Assets are depreciated as soon as they are put into operation. Depreciation is performed on a straight-line basis over the prospective useful lives of the relevant assets. The anticipated economic or technical useful life is used to determine the expected useful life of property, plant, and equipment.

	Years
Own buildings and investments in third-party buildings	8–50
Plant and Machinery	3–15
Fixtures, fittings, and equipment	3–10

To the extent the nature of the asset concerned is not modified and no additional future benefit arises, maintenance and repair work are booked as current expenses in the year in which they occur. Replacement investments and value-enhancing investments are capitalised and depreciated over either the new or the original useful life. In the case of asset disposals, the difference between the carrying amounts and the net realisable value is booked through the income statement in either other operating income or other operating expenses.

When a decision to sell property, plant, and equipment is made and the conditions set out in IFRS 5 are met, the performance of an impairment test is mandatory. If necessary, the asset is written down to the realisable amount less costs to sell still to be incurred and is then no longer depreciated until the date of sale.

Government Grants

According to IAS 20 government grants for property, plant, and equipment are presented as reductions of the acquisition and/or manufacturing costs.

Leases

In keeping with IAS 17, the allocation of a leased asset to the lessor or lessee is based on the transfer of all material risks and rewards incidental to ownership of the asset.

Assets obtained through finance leases are capitalised at the fair value or lower present value of the minimum lease payments at the acquisition date from the viewpoint of the lessee, and depreciated over their useful lives. The capitalised value of assets corresponds to the present value of the lease payments outstanding at the balance sheet date.

Assets obtained through operating leases are allocated to the lessor. The lessee recognises the lease payments as an expense in equal instalments over the term of the lease.

Notes to the Consolidated Financial Statements 2007**Borrowing Costs**

Under the benchmark treatment pursuant to IAS 23 borrowing costs are recognised in the income statement in the period in which they are incurred.

Investments in Associated Companies

As a rule, associated companies are included in the consolidated financial statements applying the equity method. At first, associated companies are reported in the balance sheet at cost and in the following periods at the amortised pro rata share in net assets. The carrying amounts are increased and/or decreased annually by the pro rata results, distributed dividends, and other changes in equity. An impairment loss is recognised if the recoverable amount is lower than the carrying amount.

Inventories

Inventories are assets held for sale as part of the normal operating business (finished goods), assets that are still in the process of production (work in progress) or that are consumed as part of the manufacturing of products or the rendering of services (materials and production supplies).

Inventories are valued at acquisition or production cost or the lower net realisable value at the balance sheet date. The valuation of materials and production supplies is carried out in accordance with the moving average cost method. Write-downs are made where inventory turnover is too low or it is foreseeable that inventories will not be used.

Receivables

Trade receivables and other current assets are shown at nominal value, if necessary less impairment losses. Foreign currency receivables are valued at foreign currency bid price at the balance sheet date. Write-ups and write-downs resulting from the valuation of foreign currency receivables are booked through the income statement.

Tax receivables and tax liabilities are offset when they relate to the same tax authority and the company has a right to offset the items.

Cash and Cash Equivalents

Current financial assets are composed of cash in hand, cheques, and cash at banks with an initial remaining time to maturity of a maximum of three months and are reported under cash and cash equivalents. They are measured mark to market as of the balance sheet date.

Liabilities and Provisions

Liabilities are shown at the higher of either acquisition cost or the amount repayable. Foreign currency liabilities are valued at the foreign currency offer price at the balance sheet date. Write-ups and write-downs resulting from the valuation of foreign currency liabilities are booked through the income statement.

Provisions for pensions and other post-retirement benefits as well as for severance payments and anniversary bonuses are valued using the projected unit credit method. Under this method anticipated benefits are distributed over the working lifespan of the employees until retirement. Anticipated future salary increases are taken into account. The amounts of the provisions are determined on the basis of an actuarial opinion prepared by an actuary as of the balanced sheet date.

Deferred tax is calculated according to the liability method, using the tax rate expected to apply at the balance sheet date when the temporary differences reverse. Other provisions are formed to reflect the level of uncertain liabilities, recognising the amount associated with the highest level of probability of occurrence.

Recognition of Revenues and Expenses

Revenues arising from the provision of goods and services are realised when all major risks and opportunities arising from the delivered object have been transferred to the buyer. Operating expenses are recognised when the service is rendered or a delivery is received, or at the time the expenses are incurred.

Financial Instruments

Securities and shares in non-consolidated associated companies that are not consolidated according to the equity method as well as other investments are classified as available for sale pursuant to IAS 39. They are measured at fair value provided that a reliable fair value can be determined. Unrealised profits and losses are recognised in equity. In the case of sales, the unrealised profit and/or loss that up to that point had been reported as equity in the balance sheet will be reported in the income statement. In the event of expected permanent impairment, an impairment loss is recorded in the income statement.

To the extent that no value discounts are required, interest-bearing borrowings are reported at nominal value (amortised costs); non-interest bearing borrowings and interest-bearing borrowings with low rates of interest are discounted accordingly.

The fair value option is not used within the PALFINGER Group.

The fair value of financial instruments is the amount for which a financial instrument could be exchanged between knowledgeable, willing, and independent parties in an arm's length transaction. The fair value is frequently

Notes to the Consolidated Financial Statements 2007

identical to the market price, and therefore its calculation is based on market information available at the balance sheet date. The values listed may diverge from values realised later due to varying determinants.

In order to minimise the risk of fluctuations with respect to payments received in the future, expected foreign currency income in US dollars for the following financial year is hedged in the PALFINGER Group by means of forward currency contracts. The special hedge accounting principles as stipulated by IFRS 39 are applied to ensure compensation on an accrual basis for the effects of hedged transactions and the hedging instrument in the income statement. According to IAS 39 the market value of forward contracts arising from the valuation of forward contracts at the balance sheet date after deduction of deferred taxes is reported in equity in the balance sheet as a reserve. The reserve will be reversed to income in line with future proceeds generated in the relevant financial year.

Stock Option Programme

In the 2003 financial year PALFINGER AG implemented a stock option programme in the form of an equity-settled plan for members of the Management Board.

In 2003 and 2004 Management Board members Eduard Schreiner, Herbert Ortner, and Wolfgang Pilz were each granted 12,000 stock options under this plan. With the approval of the Annual General Meeting, the Chairman of the Management Board, Wolfgang Anzengruber, was granted 20,000 stock options in the 2005 financial year. Each stock option may be exercised in exchange for four shares (after the stock split). The Company has currently no other stock option plans in place.

The objective of the programme is to link the amount of remuneration directly to long-term operating performance. Management should align its objectives with those of the shareholders of the Company and have a share in the success of the Company.

In order to be eligible to exercise stock options, a participant in the plan must have been in uninterrupted employment with the Group or company forming part of the PALFINGER Group not only at the time of exercise but also during a period of at least three years preceding the time of exercise. Furthermore, the average EBT ratio (ratio of earnings before taxes to revenues) as reported in the consolidated financial statements of the Group must have been at least five percent for each of the three balance sheet dates preceding the date the option is exercised.

The maximum number of shares available for subscription is equivalent to the number of options issued. If the EBT ratio is less than five percent, no options may be exercised and there is no entitlement to subscription. If the EBT ratio is five percent, the entitled person enjoys the right to exercise 25 percent of his or her stock options at the relevant exercise date. If the EBT ratio exceeds five percent, the number of stock options to be exercised by a person at the relevant exercise date rises in linear progression.

With exercise notice of 2 April 2007, Wolfgang Anzengruber exercised his option and was granted 10,000 shares from PALFINGER AG's holding of own shares at a subscription price of EUR 9.84 (EUR 39.35 prior to the stock split) per share.

With exercise notices of 6 April 2006, Herbert Ortner and Wolfgang Pilz exercised their options and in line with the provisions of the stock option programme were granted 5,160 shares each from PALFINGER AG's holding of own shares at a subscription price of EUR 5.78 (EUR 23.13 prior to the stock split) per share.

The average share price during the 2007 financial year was EUR 32.82 after the stock split (previous year: EUR 18.83 and EUR 75.31 prior to the stock split) per share.

Number of stock options	2007	2006
At 1 Jan	38,000	50,000
Options granted	0	0
Options expired	0	1,680
Options exercised	10,000	10,320
Options lapsed	0	0
At 31 Dec	28,000	38,000

The fair value of the options granted is recognised as staff costs and offset against equity. The fair value is determined at the date the option is granted and expensed over a period during which the employees acquire the unconditional entitlement to the options granted (vesting period). An option-pricing model based on binomial methodology is used to determine the fair value of options, taking into account the terms and conditions on which the options were granted. The amount, which is to be reported as an expense, is adjusted to take into account the effect of anticipated staff turnover in order to reflect the actual number of options that may be exercised in the future.

	Eduard Schreiner	Herbert Ortner	Wolfgang Pilz	Wolfgang Anzengruber
Number of stock options	6,000	6,000	6,000	10,000
Exercise price in EUR after stock split	3.82	5.78	5.78	9.84
Exercise period within 12 weeks after the Annual General Meeting	2008	2009	2009	2010
Price of a Bermudan option in EUR as of the valuation date *)	1.01	7.08	7.08	12.7
Underlying volatility	31.00%	28.00%	28.00%	27.10%
Valuation date	16 Mar 2003	16 Apr 2004	16 Apr 2004	13 Apr 2005
Price in EUR at valuation date after stock split	3.11	6.93	6.93	11.50

*) Valuation model used: binomial options pricing model

Notes to the Consolidated Financial Statements 2007

Non-current Assets Held for Sale and Discontinued Operations

If the requirements laid down in IFRS 5 are met, an impairment test is carried out. If necessary, the assets are written down to the realisable amount less costs to sell and are then no longer depreciated until the date of sale.

Profits or losses from discontinued operations are recognised in the period in which they arise and reported separately in the income statement as discontinued operations. The income statement of the previous period is adjusted accordingly.

Use of Estimates

The preparation of the consolidated financial statements requires the use of estimates and assumptions, which may influence the reported values of assets, liabilities, and financial obligations at the balance sheet date, as well as income and expenses of the financial year. Actual results may differ from these estimates. The true and fair view principle is fully applied in the use of all estimates.

Changes in Accounting and Valuation Methods

The structure of the consolidated financial statements was adjusted in accordance with the requirements of IAS 1. In particular, the accruals for current obligations to employees and for outstanding invoices were reclassified from current provisions to other current liabilities. The comparable data from the previous year were also adapted to this new structure. This change in reporting did not have any effect on earnings and did not change equity in the comparison period. These reclassifications led to the following changes of the Group's balance sheet values as of 31 December 2006:

	TEUR	31 Dec 2006	Adjustment	31 Dec 2006 Adjusted
Non-current assets				
Deferred tax assets		0	14,043	14,043
Other non-current assets		16,985	(14,043)	2,942
Current assets				
Receivables and other current assets		109,992	(5,988)	104,004
Current tax receivables		0	5,988	5,988
Non-current liabilities				
Non-current provisions		15,685	(259)	15,426
Deferred tax liabilities		0	259	259
Current liabilities				
Current provisions		32,532	(16,130)	16,402
Current tax liabilities		0	8,133	8,133
Other current liabilities		68,204	7,997	76,201

The consolidated financial statements of PALFINGER AG as of 31 December 2007 were prepared in line with the International Financial Reporting Standards (IFRS) issued by the International Accounting Standards Board (IASB) and the interpretations of the International Financial Reporting Interpretations Committee (IFRIC) to be applied within the European Union (EU). IFRS and IFRIC interpretations, whose application is mandatory for financial years starting on or after 1 January 2008, were not applied ahead of time.

The following new IFRIC interpretations and IFRS and the following revised IAS, whose application was mandatory for the first time in the financial year 2007, resulted in changes in the consolidated financial statements of PALFINGER AG and/or clarifications of facts relevant for the Group. These changes did not have any material impact on the Group's assets, finances, and earnings during this or previous reporting periods.

IAS 1 Presentation of Financial Statements calls for the disclosure of additional information on the Group's objectives, policies, and processes for managing capital.

IFRS 7 Financial Instruments: Disclosures requires an entity to make additional qualitative and quantitative disclosures regarding risks arising in connection with financial instruments.

IFRIC 7 Applying the Restatement Approach under IAS 29 provides for how an entity should restate its financial statements in the first year it identifies the existence of hyperinflation in the economy of its functional currency, which was not the case during the last reporting period.

IFRIC 8 Scope of IFRS 2 clarifies that IFRS 2 Share-based Payment applies to arrangements where an entity makes share-based payments for apparently nil or inadequate consideration.

IFRIC 9 Reassessment of Embedded Derivatives clarifies certain aspects of the treatment of embedded derivatives under IAS 39. IFRIC 9 provides that the assessment whether or not the embedded derivatives needs to be separated from the host contract only has to be made when the entity first becomes a party to the contract.

According to **IFRIC 10 Interim Financial Reporting and Impairment**, impairment losses recognised in an interim financial statement on goodwill, the carrying amount of an equity instrument, and investments in financial assets carried at cost must not be reversed in subsequent financial statements.

IFRIC interpretations and IFRS that might be of relevance for the PALFINGER Group but whose application is not yet mandatory for these consolidated financial statements were not applied ahead of time. The PALFINGER Group does not expect the first application of these standards and interpretations in the future to have any material impact on the Group's assets, finances, and earnings.

Notes to the Consolidated Financial Statements 2007

In November 2006 the IFRIC issued **IFRIC 11 IFRS 2 – Group and Treasury Share Transactions**. This interpretation addresses how to apply IFRS 2 Share-based Payments to share-based payment arrangements involving an entity's own equity instruments or equity instruments of another entity in the group. The application of IFRIC 11 is compulsory for financial years beginning on or after 1 March 2007.

The following new IFRIC interpretations and IFRS and the following revised IAS that might be of relevance for the PALFINGER Group have been issued but not yet endorsed by the European Commission. For this reason, they are not relevant for these consolidated financial statements.

The revised version of **IAS 1 Presentation of Financial Statements**, which was issued by the IASB in September 2007 and is mandatory for all financial years starting on or after 1 January 2009, is aimed at improving users' ability to analyse and compare the information given in the financial statements.

In March 2007 the IASB issued a revised version of **IAS 23 Borrowing Costs**, which is compulsory for financial years beginning on or after 1 January 2009. According to this standard borrowing costs that are directly attributable to the acquisition, construction, or production of a qualifying asset should be capitalised as part of the cost of the asset. The current option of immediately recognising borrowing costs as an expense will be discontinued.

In November 2006 the IASB issued **IFRS 8 Operating Segments**, which replaces IAS 14 Segment Reporting. Pursuant to IFRS 8 reporting on the financial performance of the segments has to be prepared according to the so-called management approach. Accordingly, the identification of the segments and the disclosures for these segments are based on the information which is used internally by Management in evaluating segment performance and deciding how to allocate resources. The application of the standard is compulsory for financial years beginning on or after 1 January 2009.

In July 2007 the IFRIC issued the interpretation **IFRIC 14 IAS 19 – The Limit on a Defined Benefit Asset, Minimum Funding Requirements and their Interaction**. This interpretation provides guidance on how to assess the limit in IAS 19 Employee Benefits on the amount of the surplus that can be recognised as an asset. It also explains how assets or provisions under performance-oriented benefit plans may be affected when there is a statutory or contractual minimum funding requirement. The interpretation will ensure that entities recognise an asset in relation to a surplus under such plan on a consistent basis. The interpretation is mandatory for financial years beginning on or after 1 January 2008.

Notes to the Consolidated Balance Sheet**(1) Intangible Assets**

The changes in intangible assets were as follows:

TEUR	Goodwill*)	Customer base	Other intangible assets	Prepayments	Total
Acquisition cost					
At 1 Jan 2006	16,286	16,365	9,923	195	42,769
Additions	0	188	767	243	1,198
Disposals	0	0	(68)	(5)	(73)
Reclassifications	0	0	45	12	57
Foreign currency translation	0	188	(23)	0	165
At 31 Dec 2006	16,286	16,741	10,644	445	44,116
At 1 Jan 2007	16,286	16,741	10,644	445	44,116
Change in scope of consolidation	0	0	626	10	636
Additions	22,482	0	1,595	0	24,077
Additional capitalisation	0	3,166	0	0	3,166
Disposals	0	0	(1,523)	(432)	(1,955)
Reclassifications	0	0	173	1	174
Foreign currency translation	(11)	(796)	5	0	(802)
At 31 Dec 2007	38,757	19,111	11,520	24	69,412
Accumulated amortisation and impairment					
At 1 Jan 2006	0	2,448	7,190	0	9,638
Amortisation	0	1,696	1,276	0	2,972
Impairment	0	188	0	0	188
Disposals	0	0	(65)	0	(65)
Foreign currency translation	0	(24)	(13)	0	(37)
At 31 Dec 2006	0	4,308	8,388	0	12,696
At 1 Jan 2007	0	4,308	8,388	0	12,696
Change in scope of consolidation	0	0	566	0	566
Amortisation	0	1,832	1,249	0	3,081
Disposals	0	0	(1,523)	0	(1,523)
Reclassifications	0	0	35	0	35
Foreign currency translation	0	(51)	(1)	0	(52)
At 31 Dec 2007	0	6,089	8,714	0	14,803
Carrying amounts at 31 Dec 2006	16,286	12,433	2,256	445	31,420
Carrying amounts at 31 Dec 2007	38,757	13,022	2,806	24	54,609

*) Any amortisation of goodwill in the amount of TEUR 11,368 accrued up to the first application of IFRS 3 was retrospectively offset against the cost of acquisition. The figures for the previous period under review were adjusted accordingly.

Notes to the Consolidated Financial Statements 2007

Investment in other intangible assets amounted to TEUR 1,595 (previous year: TEUR 767) for concessions, patents, and licences as well as goodwill in the amount of TEUR 22,482 (previous year: TEUR 0).

The Group did not hold any internally generated intangible assets that can be capitalised.

Goodwill

Reported goodwill pertains to the following cash-generating units:

TEUR	31 Dec 2007	31 Dec 2006
CRANES segment		
Knuckle boom crane	1,319	0
HYDRAULIC SYSTEMS and SERVICES segment		
PALIFT	16,286	16,286
TAIL LIFT	21,152	0
Total	38,757	16,286

Customer Base

In the 2007 financial year retrospective customer acquisition costs of Ratcliff Palfinger Ltd., Great Britain, were capitalised in the amount of TEUR 2,742 and customer acquisition costs of Madal Palfinger S.A., Brazil, were capitalised in the amount of TEUR 424.

(2) Property, Plant, and Equipment

Changes in property, plant, and equipment were as follows:

TEUR	Land and buildings	Undeveloped	Plant and machinery	Other plant, fixtures, fittings, and equipment	Prepayments and assets under construction	Total
Acquisition cost						
At 1 Jan 2006	76,880	1,375	56,919	24,660	3,826	163,660
Additions	3,661	0	4,714	2,803	10,173	21,351
Disposals	(2)	0	(2,157)	(4,582)	(238)	(6,979)
Reclassifications	455	39	3,269	(533)	(3,287)	(57)
Foreign currency translation	(379)	(4)	(129)	(94)	(6)	(612)
At 31 Dec 2006	80,615	1,410	62,616	22,254	10,468	177,363

TEUR	Land and buildings	Undeveloped	Plant and machinery	Other plant, fixtures, fittings, and equipment	Prepayments and assets under construction	Total
At 1 Jan 2007	80,615	1,410	62,616	22,254	10,468	177,363
Change in scope of consolidation	920	0	4,667	2,380	16	7,983
Additions	12,139	2,020	15,612	10,673	21,000	61,444
Additional capitalisation	0	0	108	26	0	134
Government grants	(417)	0	(316)	0	0	(733)
Disposals	(1,409)	0	(6,733)	(4,936)	(721)	(13,799)
Reclassifications	4,007	0	9,951	826	(14,958)	(174)
Reclassification to held for sale	(3,499)	0	0	0	0	(3,499)
Foreign currency translation	446	17	77	(14)	14	540
At 31 Dec 2007	92,802	3,447	85,982	31,209	15,819	229,259
Accumulated depreciation and impairment						
At 1 Jan 2006	23,502	0	33,686	16,420	0	73,608
Depreciation	2,146	0	5,219	2,615	0	9,980
Impairment	1,960	0	0	0	0	1,960
Disposals	0	0	(2,153)	(3,910)	0	(6,063)
Reclassifications	0	0	112	(112)	0	0
Foreign currency translation	(108)	0	(70)	(74)	0	(252)
At 31 Dec 2006	27,500	0	36,794	14,939	0	79,233
At 1 Jan 2007	27,500	0	36,794	14,939	0	79,233
Change in scope of consolidation	98	0	2,559	1,548	0	4,205
Depreciation	2,826	0	6,869	2,862	0	12,557
Write-up	(1,755)	0	0	0	0	(1,755)
Additional capitalisation	0	0	116	28	0	144
Disposals	(1,011)	0	(6,548)	(4,739)	0	(12,298)
Reclassifications	(328)	0	30	263	0	(35)
Reclassification to held for sale	(2,886)	0	0	0	0	(2,886)
Foreign currency translation	162	0	(28)	(30)	0	104
At 31 Dec 2007	24,606	0	39,792	14,871	0	79,269
Carrying amounts at 31 Dec 2006	53,115	1,410	25,822	7,315	10,468	98,130
Carrying amounts at 31 Dec 2007	68,196	3,447	46,190	16,338	15,819	149,990

Notes to the Consolidated Financial Statements 2007

The net amounts represent carrying amounts depreciated through use, which are acquisition costs minus accumulated depreciation. The net value of property, plant, and equipment in the amount of TEUR 149,990 (previous year: TEUR 98,130) rose by TEUR 51,860 or 52.8 percent compared with 2006.

In the 2007 financial year, investment in property, plant, and equipment totalled TEUR 61,444 (previous year: TEUR 21,351). Additions resulted from rationalisation and capacity expansion investments made at the production sites as well as from the replacement of the company aircraft.

Land and buildings reflected the real estate values of developed properties amounting to TEUR 8,314 (previous year: TEUR 8,299).

In connection with the implementation of the business location concept in Austria and the planned demolition of some parts of the building, an impairment loss in the amount of TEUR 1,960 was recognised for the company building in Berghheim, Salzburg in the 2006 financial year. Due to changes in the business location concept and the plans to continue to use the company building, a write-up of TEUR 1,755 was recognised in the 2007 financial year.

Prepayments and assets under construction were reported at cost and represented assets which were under construction as of the balance sheet date, totalling TEUR 15,782 (previous year: TEUR 9,734).

(3) Investments in Associated Companies

An associated company is defined as an entity over which the investor has significant influence, i.e. the power to participate in the operating policy decisions, without the entity being an affiliated company. There is a rebuttable presumption that the investor holds 20 to 50 percent of the voting power. Associates are generally accounted for using the equity method.

The names of the companies included in the consolidated financial statements using the equity method are stated in the attached statement of investments.

TEUR	2007	2006
At 1 Jan	8,054	7,921
Additions	0	70
Share in the net profit or loss for the period	5,755	2,106
Dividends	(1,564)	(2,043)
Foreign currency translation	(45)	0
Change in consolidation method	(249)	0
At 31 Dec	11,951	8,054

With the acquisition of the remaining 80 percent in the Croatian PIR metal d.o.o. during the 2007 financial year, full consolidation replaced consolidation using the equity method. In accordance with IFRS 3, a revaluation of net assets was made and, on this basis, the goodwill for this transaction was determined separately.

(4) Deferred Taxes

Deferred tax assets amounted to TEUR 19,663 (previous year: TEUR 14,043). TEUR 5,985 (previous year: TEUR 3,858) of this amount were deferred tax assets recognised on tax-loss carry forwards, and taxes directly recognised in equity amounted to TEUR 1,251 (previous year: TEUR 629).

TEUR	31 Dec 2007	31 Dec 2006
Deferred tax assets		
Non-current assets	5,625	6,569
Current assets	2,866	1,822
Non-current liabilities	5,540	3,485
Current liabilities	3,268	1,515
	17,299	13,391
Deferred tax liabilities		
Non-current assets	(6,958)	(2,348)
Current assets	(749)	(712)
Non-current liabilities	(483)	(130)
Current liabilities	(1,099)	(275)
	(9,289)	(3,465)
Deferred tax assets on loss carry forwards	5,985	3,858
Deferred taxes	13,995	13,784
of which		
deferred tax assets	19,663	14,043
deferred tax liabilities	(5,668)	(259)

Notes to the Consolidated Financial Statements 2007

The following table presents deferred taxes broken down by country:

TEUR	31 Dec 2007	31 Dec 2006
Brazil	1,547	1,479
Bulgaria	104	0
China	50	0
Germany	3,500	2,471
Great Britain	(2,614)	0
France	1,603	1,396
Italy	15	22
Canada	590	79
Croatia	150	0
Austria	7,884	8,083
Slovenia	420	112
USA	746	142
Total	13,995	13,784

(5) Other Non-current Assets

Other non-current assets are broken down as follows:

TEUR	31 Dec 2007	31 Dec 2006
Loans	0	447
Securities	550	620
Reinsurance amounts	2,141	1,805
Deferred expenses	17	43
Miscellaneous other non-current assets	24	27
Total	2,732	2,942

Securities held as non-current assets comprise shares in investment funds and bonds.

Reinsurance amounts concern repurchase rights for life insurance policies which do not meet the criteria for a plan asset in accordance with IAS 19.

(6) Inventories

Inventories comprise the following:

TEUR	31 Dec 2007	31 Dec 2006
Materials and production supplies	59,123	42,035
Work in progress	30,687	20,294
Finished goods and goods for resale	61,769	50,616
Prepayments	315	1,304
Total	151,894	114,249

Materials and production supplies were valued at the moving average cost method. Besides direct materials and production costs, work in progress and finished goods also contain appropriate shares of materials and manufacturing overheads as well as production-related administrative expenses. They were valued at budgeted manufacturing cost.

Allowances for materials and production supplies relate to unusable inventory as well as, in the case of finished goods, to write-downs associated with loss-free valuation at market values.

(7) Receivables and Other Current Assets

Receivables and other current assets are illustrated in the following table:

TEUR	31 Dec 2007	31 Dec 2006
Trade receivables	113,918	89,987
Receivables from associated companies	5,658	2,730
Receivables from derivative financial instruments	917	1,039
Receivables relating to social security and other taxes	7,515	0
Other receivables	3,065	4,366
Deferred expenses	1,957	873
Securities	82	5,009
Total	133,112	104,004

Trade receivables are amounts owed by various customers in Austria and abroad.

Receivables from associated companies in the amount of TEUR 5,658 (previous year: TEUR 2,730) are due for merchandise sold or services performed.

Notes to the Consolidated Financial Statements 2007

Other receivables amounted to TEUR 3,065 (previous year: TEUR 4,366) and consisted mainly of receivables from contractual penalties and the research bonus.

Short-term investments in money market products amounted to TEUR 82 (previous year: TEUR 5,009).

Based on experience, allowances for doubtful debts were made in the amount of TEUR 3,649 (previous year: TEUR 3,742) to take into account insolvency risks. These allowances were the following:

TEUR	Specific bad-debt allowances	Specific bad-debt allowances	Bad-debt allowances calculated on a lump-sum basis	Bad-debt allowances calculated on a lump-sum basis
At 1 Jan	3,264	4,567	478	631
Change in scope of consolidation	264	0	13	0
Allocation	1,913	1,707	160	255
Use	(371)	(538)	0	(49)
Reversal	(1,579)	(1,579)	(137)	(171)
Foreign currency translation	(264)	(893)	8	(188)
At 31 Dec	3,127	3,264	522	478

(8) Cash and Cash Equivalents

Cash in hand and cash at bank are included in the item funds recognised in the consolidated cash flow statement.

TEUR	31 Dec 2007	31 Dec 2006
Cash in hand	860	175
Cash at bank	1,699	30,361
Total	2,559	30,536

(9) Non-current Assets Held for Sale

In the course of the sales process initiated, the property previously held as financial investment was reclassified as non-current assets held for sale.

Following this reclassification an impairment test was carried out in accordance with IFRS 5, and it was determined that there is no need to form an impairment loss. The property will no longer be written down until the actual date of sale.

As of 31 December 2007 the market value amounted to TEUR 683 and was based on a valuation carried out by an independent expert. This valuation was in line with international valuation standards and was based on market prices of similar property. In the 2007 financial year, a write-up to the market value was made in the amount of TEUR 71.

(10) Share Capital

The Company's share capital is divided into 37,135,000 (previous year: 9,283,750) no-par-value shares. In the 2007 financial year, the share capital of PALFINGER AG was increased by EUR 18,567,500 from previously EUR 18,567,500 to EUR 37,135,000 by means of a conversion of the corresponding partial amount of the appropriated capital reserve recorded in the financial statements as of 31 December 2006 pursuant to the provisions of the Austrian Act on Capital Adjustments (Kapitalberichtigungsgesetz). According to the resolution passed at the Annual General Meeting of 28 March 2007 no additional no-par-value bearer shares were issued.

As of 29 June 2007, the four-for-one stock split resolved upon at the Annual General Meeting of 28 March 2007 was implemented, resulting in an increase in no-par-value shares from previously 9,283,750 to 37,135,000.

(11) Additional Paid-in Capital

Capital reserves concern only tied capital reserves from capital increases pursuant to stock corporation law. In the 2007 financial year, capital reserves decreased from TEUR 53,757 to TEUR 35,190 as a result of the capital increase from corporate funds.

(12) Retained Earnings

In addition to own shares deducted, retained earnings comprise actuarial gains and losses in accordance with IAS 19, reserves for stock options pursuant to IFRS 2, the consolidated net profit for the period and accumulated results from previous years.

Treasury Stock

Treasury stock acquired by the Company in the 2002 and 2003 financial years in accordance with the resolution of the Annual General Meeting of 29 October 2002 were deducted from retained earnings. As of 31 December 2007, holdings of treasury stock amounted to 1,805,000 shares (previous year: 461,411 shares).

Notes to the Consolidated Financial Statements 2007

This change results primarily from the transfer of shares associated with the approved stock option programme.

Shares	2007	2006
At 1 Jan	461,411	471,731
Exercise of stock option	(10,000)	(10,320)
Compensation of minority shareholder	(161)	0
4-for-1 stock split as of 29 June 2007	451,250	461,411
	1,805,000	1,805,000
At 31 Dec	1,805,000	461,411

Actuarial Gains and Losses in Accordance with IAS 19

Actuarial gains and losses in accordance with IAS 19 are directly recognised in equity to the full extent in the period in which they are incurred. In the 2007 financial year TEUR – 2,183 were directly recognised in equity (previous year: TEUR 203).

Reserve Pursuant to IFRS 2

The fair value of the options granted within the framework of the stock option programme is recognised as staff costs over the vesting period. The reserve pursuant to IFRS 2 reflects accumulated staff costs up to 31 December 2007. When the stock options are exercised or expire, they will be set off against retained earnings.

The reserve pursuant to IFRS 2 is as follows:

TEUR	2007	2006
At 1 Jan	184	151
Allocation	57	102
Use	(98)	(69)
At 31 Dec	143	184

Consolidated Net Profit for the Period

The Group generated a net profit for the 2007 financial year in the amount of TEUR 73,978 (previous year: TEUR 56,603). This is equivalent to an increase of TEUR 17,375 or 30.7 percent in comparison with the previous year.

Earnings per Share

Pursuant to IAS 33 earnings per share are calculated by dividing the consolidated net profit for the period by the weighted average number of shares outstanding. In the 2007 financial year, the weighted average number of outstanding shares amounted to 35,319,617 shares (previous year: 8,827,442 shares or 35,309,768 shares after the stock split).

On the basis of the consolidated net profit for the period in the amount of TEUR 73,978 (previous year: TEUR 56,603) undiluted earnings per share were EUR 2.09 (previous year: EUR 6.41 or EUR 1.60 after the stock split). Diluted earnings per share were identical with undiluted earnings per share.

Dividend per Share

The dividend distribution from the consolidated net profit for the year proposed by the Annual General Meeting on 26 March 2008 is EUR 0.70 (previous year: EUR 2.20 or EUR 0.55 after the stock split) per share or TEUR 24,731 (previous year: TEUR 19,409).

(13) Revaluation Reserve

If the acquisition of a subsidiary takes place in more than one transaction, each of these transactions will be treated separately as regards the diverging amounts as stipulated in IFRS 3.58. The adjustment of the amounts recognised is, in character, a revaluation and is credited directly to equity under the heading of revaluation reserve. Within the framework of the successive share purchases the amount of TEUR – 112 was directly recognised in equity in the course of the revaluation of PIR metal d.o.o., Croatia.

(14) Valuation Reserves Pursuant to IAS 39

As of 31 December 2007, the reserve pursuant to IAS 39 stood at TEUR 519 (previous year: TEUR 776). In the 2007 financial year, changes in the value of financial instruments that have been taken directly to equity resulted in a decrease of equity by TEUR 257.

Changes in the value of derivative financial instruments taken directly to equity to be used for hedging against future cash flows are set off against the cash flow hedging reserve and reported in the statement of changes in equity under reserves pursuant to IAS 39.

TEUR	2007	2006
At 1 Jan	776	(1,955)
Changes of the fair value taken directly to equity	698	1,035
deferred taxes thereon	(179)	(259)
Realised in the income statement	(1,035)	2,607
deferred taxes thereon	259	(652)
At 31 Dec	519	776

Notes to the Consolidated Financial Statements 2007

(15) Foreign Currency Translation Reserve

This position contains differences from the foreign currency translation resulting in the course of the consolidation of foreign subsidiaries with regard to the closing rates and, in the 2007 financial year, resulted in a change of the foreign currency translation reserve to TEUR – 4,923 (previous year: TEUR – 6,053). This corresponds to a change in the amount of TEUR 1,130.

(16) Minority Interests

This item contains minority interests in the equity of fully consolidated companies and primarily includes shareholders in Palfinger Europe GmbH, EPSILON Kran GmbH, and Madal Palfinger S.A.

In the 2007 financial year, Palfinger Industrieanlagen GmbH was merged into PALFINGER AG. Palfinger Consult AG was compensated for its five-percent minority interest in Palfinger Industrieanlagen GmbH by being granted shares of PALFINGER AG of corresponding value. This compensation was set off against retained earnings.

(17) Non-current Financial Liabilities

Non-current financial liabilities comprise the following:

TEUR	Currency	Maturity	Effective interest rate	31 Dec 2007	31 Dec 2006
Loan					
	EUR ¹⁾	1 July 2013	4.1% p.a.	28,747	21,296
	USD	31 Jan 2016	6.2% p.a.	6,029	5
	CHF ²⁾	31 Mar 2010	5.2% p.a.	0	1,422
	BRL	31 Dec 2009	12.2% p.a.	3,539	8,843
	Total			38,315	31,566

¹⁾ Variable-rate loan (maturity: 30 Sep 2016) redeemed in advance in 2007

²⁾ CHF loan redeemed in advance in 2007

Valuation is performed at amortised cost. Liabilities in foreign currencies were translated at the closing rate or at the hedged rate. In case of hedging, liabilities were adjusted in accordance with IAS 39 by the corresponding change in the value of the hedged risk provided that hedge accounting is applicable.

Deferred interest expenses are contained in other current liabilities.

The effective interest rate is the average interest burden in percent relating to the average carrying amount in the 2007 financial year, after interest and currency hedging have been taken into account. In 2007 this value amounted to 5.2 percent (previous year: 6.2 percent). The fair value of non-current financial liabilities was derived from the market information available on the balance sheet date and corresponds to the carrying amount.

(18) Non-current Provisions

The following table shows non-current provisions.

TEUR	31 Dec 2007	31 Dec 2006
Provisions for severance payments	13,081	10,022
Pension provisions	4,614	2,641
Anniversary bonus provisions	2,885	2,255
Other non-current provisions	523	508
Total	21,103	15,426

Pension Provisions

Some Group companies are committed by the terms of individual contracts with certain employees to provide supplementary retirement pensions payable after their retirement. The amount of these pensions is calculated on the basis of length of service and remuneration at the time of retirement.

TEUR	31 Dec 2007	31 Dec 2006	31 Dec 2005	31 Dec 2004	31 Dec 2003
Defined benefit obligation	4,675	2,641	3,114	2,769	3,282
Plan asset	(61)	0	0	0	0
Pension provisions	4,614	2,641	3,114	2,769	3,282
TEUR	2007	2006	2006	2007	2006
Defined benefit obligation as of 1 Jan	2,641	3,114		2,641	3,114
Change in basis of consolidation	2,691	0		2,691	0
Current service cost	85	106		85	106
Interest cost	117	138		117	138
(Actuarial gains)/losses	(69)	(205)		(69)	(205)
Past service cost	0	(372)		0	(372)
Benefits paid	(790)	(140)		(790)	(140)
Defined benefit obligation as of 31 Dec	4,675	2,641		4,675	2,641
TEUR	2007	2006	2006	2007	2006
Plan asset as of 1 Jan	0	0		0	0
Change in basis of consolidation	61	0		61	0
Plan asset as of 31 Dec	61	0		61	0

Notes to the Consolidated Financial Statements 2007

Pension provisions were valued as of the balance sheet date on the basis of actuarial reports. The following assumptions were made:

- Age of retirement: 65 years (previous year: 65 years)
- Interest rate: 5.0 percent p.a. (previous year: 4.5 percent p.a.)
- Pension increase: 1.5 percent p.a. (previous year: 1.5 percent p.a.)

The calculation of the pension provisions was performed on 31 December 2007 using actuarial principles and taking into account the calculation rules under IAS 19. The obligations are valued using the projected unit credit method. The calculations are based on the earliest possible pensionable age according to the 2004 Pension Reform (Austrian Budget Accompanying Act of 2003 [Budgetbegleitgesetz 2003]), taking into consideration transitional regulations. In the case of women entitled to such benefits, the computed pensionable age has been raised in steps corresponding to the Austrian Federal Constitutional Act concerning different age limits for male and female citizens covered by Social Security (Bundesverfassungsgesetz über unterschiedliche Altersgrenzen von männlichen und weiblichen Sozialversicherten). These bases for calculation were established using Austrian pension tables AVÖ-1999-P (version for salaried employees).

Provision for Severance Payments

Severance payments are one-time settlements required under labour law, payable on termination of employment by the employer or by mutual agreement or on retirement to employees whose employment status commenced before 1 January 2003. They are calculated on the basis of the length of service and the amount of remuneration. The amount of the provisions for severance payments was calculated in accordance with actuarial principles.

TEUR	31 Dec 2007	31 Dec 2006	31 Dec 2005	31 Dec 2004	31 Dec 2003
Defined benefit obligation	13,081	10,022	9,285	7,709	7,399
TEUR					
	2007				2006
Defined benefit obligation as of 1 Jan	10,022				9,285
Change to current liabilities	(79)				0
Current service cost	772				733
Interest cost	443				409
(Actuarial gains)/losses	2,594				(76)
Benefits paid	(671)				(329)
Defined benefit obligation as of 31 Dec	13,081				10,022

Valuation was based on the following parameters:

- Interest rate: 5.0 percent p.a. (previous year: 4.5 percent p.a.)
- Salary increases: 4.5 percent p.a. (previous year: 3.0 percent p.a.)
- Fluctuation discount: 2.0 percent p.a. (previous year: 2.0 percent p.a.)

In the case of employees whose employment commenced after 1 January 2003 this obligation is transferred to a contribution-based system. These payments made to an external pension fund are reported as expenses and amount to 1.53 percent of remuneration.

Anniversary Bonus Provisions

Provisions for anniversary bonuses derived from collective bargaining and/or company agreements were calculated using the same parameters as for the provision for severance payments.

TEUR	31 Dec 2007	31 Dec 2006	31 Dec 2005	31 Dec 2004	31 Dec 2003
Defined benefit obligation	2,885	2,255	2,019	1,589	1,466
TEUR				2007	2006
Defined benefit obligation as of 1 Jan				2,255	2,019
Current service cost				203	184
Interest cost				100	90
(Actuarial gains)/losses				399	(7)
Benefits paid				(72)	(31)
Defined benefit obligation as of 31 Dec				2,885	2,255

Other Non-current Provisions

The changes in other non-current provisions are shown in the following table:

TEUR	2007	2006
At 1 Jan	508	510
Interest cost	15	14
Use	0	(16)
At 31 Dec	523	508

Other non-current provisions primarily concern obligations to employees.

Notes to the Consolidated Financial Statements 2007

(19) Other Non-current Liabilities

Other non-current liabilities are comprised of the following:

	31 Dec 2007	31 Dec 2006
Trade payables	0	3,047
Other liabilities	1,176	1,127
Total	1,176	4,174

Other liabilities relate to severance-type obligations as well as performance-related claims by employees of foreign Group companies.

(20) Current Financial Liabilities

Current financial liabilities are shown in the following table:

	31 Dec 2007	31 Dec 2006
Overdraft facilities		
EUR	16,561	8,364
CHF	0	102
USD	7,121	3,938
CAD	1,585	611
BRL	6,982	2,226
HRK	1,349	0
Export loans	10,000	0
Total	43,598	15,241

(21) Current Provisions

Changes in current provisions are illustrated in the following:

	2007	2006
At 1 Jan	16,402	19,684
Change in scope of consolidation	506	0
Allocation	12,853	10,632
Use	(14,249)	(11,864)
Reversal	(1,737)	(2,016)
Foreign currency translation	288	(34)
At 31 Dec	14,063	16,402

Current provisions cover primarily provisions for staff liabilities that have not yet fallen due of TEUR 1,528 (previous year: TEUR 3,810), guarantee and warranty expenses of TEUR 11,432 (previous year: TEUR 9,844), as well as provisions for imminent losses in outstanding contracts of TEUR 86 (previous year: TEUR 567).

(22) Other Current Liabilities

Other current liabilities are broken down as follows:

	31 Dec 2007	31 Dec 2006
TEUR		
Trade payables	65,036	53,759
Liabilities to associated companies	888	6
Prepaid orders	2,479	2,047
Liabilities on accepted bills of exchange	392	598
Liabilities to employees	17,841	10,736
Liabilities relating to social security and other taxes	8,733	2,672
Other liabilities	3,588	5,892
Deferred income	319	491
Total	99,276	76,201

Liabilities due to associated companies in the amount of TEUR 888 (previous year: TEUR 6) resulted from the provision of goods and services.

Liabilities to employees in the amount of TEUR 17,841 (previous year: TEUR 10,736) include deferrals for unused vacation time, incentive bonuses, and compensatory time off, as well as wage and salary expenditures payable.

Other liabilities totalling TEUR 3,588 (previous year: TEUR 5,892) primarily relate to deferrals for premiums and performance-related bonuses.

Notes to the Consolidated Financial Statements 2007

Notes to the Consolidated Income Statement

(23) Revenue

TEUR	Jan-Dec 2007	Jan-Dec 2006
Domestic sales revenue	57,922	41,814
Export revenue	390,193	313,440
Foreign sales revenue	247,508	229,951
Total	695,623	585,205

(24) Changes in Inventories and Own Work Capitalised

TEUR	Jan-Dec 2007	Jan-Dec 2006
Changes in inventories	11,236	14,983
Own work capitalised	66	175
Total	11,302	15,158

Changes in inventories consist of changes in inventories of finished goods and work in progress compared with 2006.

Besides direct materials and production costs, own work capitalised also contains appropriate shares of materials and manufacturing overheads.

(25) Other Operating Income

TEUR	Jan-Dec 2007	Jan-Dec 2006
Income from the disposal of intangible assets and property, plant, and equipment	166	90
Income from the write-up of intangible assets and property, plant, and equipment	1,755	0
Income from the reversal of provisions	1,737	2,016
Income from the reversal of impairment losses to receivables	1,816	1,750
Exchange rate differences	180	0
Miscellaneous other operating income	6,084	8,787
Total	11,738	12,643

Miscellaneous other operating income of the 2007 financial year primarily contains rental income of TEUR 203 (previous year: TEUR 183), research bonus income of TEUR 1,008 (previous year: TEUR 1,538), income from charges for services of TEUR 1,306 (previous year: TEUR 1,674), insurance income of TEUR 250 (previous year: TEUR 114),

income from the sale of advertising media of TEUR 505 (previous year: TEUR 495), as well as other income in the amount of TEUR 2,445 (previous year: TEUR 2,781).

(26) Materials and External Services

TEUR	Jan-Dec 2007	Jan-Dec 2006
Cost of materials	(347,746)	(298,749)
Cost of external services	(23,301)	(17,614)
Total	(371,047)	(316,363)

Materials intensity (materials expenditure, including cost of sales, expressed as a percentage of revenue and adjusted for changes in inventories) changed by 0.2 percentage points from 52.7 percent to 52.5 percent in 2007.

(27) Staff Costs

TEUR	Jan-Dec 2007	Jan-Dec 2006
Wages and salaries	(107,771)	(94,831)
Expenses for severance payments	(1,210)	(1,372)
Pension expenses	(452)	(191)
Expenses for statutory social security contributions and other pay-related contributions	(25,817)	(21,995)
Other staff benefits	(5,933)	(4,498)
Total	(141,183)	(122,887)

Expenses for severance payments include payments made to external severance pay funds for employees in the amount of TEUR 258 (previous year: TEUR 167).

Staff costs of TEUR 57 (previous year: TEUR 102) were reported in the 2007 financial year relating to the granting of stock options as part of the stock option programme and in accordance with IFRS 2.

The increase in staff costs resulted from individual salary increases and salary increases based on collective bargaining agreements as well as to the increase in the number of employees on the Group payroll.

Notes to the Consolidated Financial Statements 2007

(28) Depreciation, Amortisation, and Impairment Expenses

TEUR	Jan-Dec 2007	Jan-Dec 2006
Depreciation and amortisation	(15,638)	(12,952)
Impairment	0	(2,148)
Total	(15,638)	(15,100)

Changes in depreciation, amortisation, and impairment are discussed in detail in the sections on intangible assets and property, plant, and equipment.

Depreciation and amortisation in the amount of TEUR 15,638 only relate to depreciation of property, plant, and equipment and amortisation of intangible assets. Of the impairment losses allocated in 2006, TEUR 1,960 relate to the company building at the Berghelm, Salzburg site and TEUR 188 to capitalised rights in the MOBILIER cash-generating unit.

(29) Other Operating Expenses

TEUR	Jan-Dec 2007	Jan-Dec 2006
Taxes other than those on income	(2,134)	(2,421)
Losses on the disposal of intangible assets and property, plant, and equipment	(514)	(32)
Guarantees and warranties	(14,907)	(12,683)
Trade fairs, distribution, and marketing	(8,009)	(7,142)
Consultancy services	(7,849)	(7,479)
Rentals and leases	(5,152)	(5,883)
Repairs and maintenance	(7,045)	(7,119)
Travel and communications	(8,399)	(7,563)
Losses on receivables and impairment losses	(1,702)	(1,375)
Insurance	(2,255)	(2,599)
Temporary workers and other third-party services	(12,101)	(9,239)
Outgoing freight costs	(11,952)	(8,493)
Commissions	(787)	(869)
Miscellaneous other operating expenses	(8,351)	(8,733)
Total	(91,157)	(81,630)

Miscellaneous other operating expenses primarily comprise office supplies and computer expendables of TEUR 775 (previous year: TEUR 602), the vehicle fleet of TEUR 2,510 (previous year: TEUR 1,786), expenses for imminent losses of TEUR 60 (previous year: TEUR 413), currency translation differences of TEUR 23 (previous year: TEUR 341),

bank charges of TEUR 300 (previous year: TEUR 461), as well as licences and computer fees of TEUR 1,359 (previous year: TEUR 1,414).

(30) Income from Associated Companies

TEUR	Jan-Dec 2007	Jan-Dec 2006
Palfinger France S.A.	5,079	942
Palfinger Southern Africa (Pty) Ltd.	13	79
PIR metal d.o.o. (up to 31 July 2007)	30	4
STEPA Farmkran GmbH	633	1,081
Total	5,755	2,106

(31) Interest and Other Financial Expenses

TEUR	Jan-Dec 2007	Jan-Dec 2006
Interest income	1,660	729
Income from the disposal of securities	250	72
Interest expense	(3,821)	(3,454)
Interest expense from finance lease	(503)	(105)
Interest component of social capital	(607)	(509)
Impairment of securities	(22)	(16)
Losses on the disposal of securities	(51)	(15)
Exchange rate differences	93	(251)
Total	(3,001)	(3,549)

(32) Income Tax Expense

The rate of corporation tax applicable to the PALFINGER AG parent company remained at 25 percent, which is the same rate as the previous year.

With the passing of the 2005 Tax Reform Act (Steuerreformgesetz 2005) the Austrian lawmaker enabled companies to establish corporate tax groups. Following the calculation of losses incurred by each of the companies in the Group, taxable results of the companies are assigned to the leading corporation of each tax group. To offset passed-on taxable results, a tax rate – based on the stand-alone method – is fixed in the Group company agreements.

Notes to the Consolidated Financial Statements 2007

	TEUR	Jan-Dec 2007	Jan-Dec 2006
Current income tax expense		(25,783)	(19,652)
Deferred taxes		1,459	3,748
Total		(24,324)	(15,904)

An income tax rate of 25 percent was employed for the calculation of tax deferrals for companies based in Austria, and respective local rates were applied for companies located abroad.

Calculation of the Effective Tax Rate

The difference between the book income tax expense (profit before tax multiplied by the national tax rate of 25 percent) and the effective income tax expense in the 2007 financial year, as shown in the consolidated income statement, is calculated as follows:

	TEUR	31 Dec 2007	31 Dec 2006
Profit before income tax		102,392	75,583
Effective tax rate of the Group		25.0%	25.0%
Book income tax expense		25,598	18,896
Tax-reducing factors			
Research and education allowances, investment growth premiums		(279)	(527)
Adjustment to foreign tax rates		(578)	(1,119)
Tax rate changes		(575)	0
Tax-free income from trade investments		(1,439)	(16)
Other tax reduction items		(3,468)	(2,042)
Loss carry forwards from previous years		(795)	0
Share valuations		0	(2,041)
Tax-increasing factors			
Adjustment to foreign tax rates		1,157	0
Tax rate changes		858	0
Non-capitalised loss carry forwards		0	425
Other non-tax-deductible expenses		2,183	1,604
Tax payments not identified with a specific period		1,157	77
Share valuations		505	647
Income tax expense		24,324	15,904

The Group's effective tax rate, in other words, the total income tax expense expressed as a percentage of the profit before income tax, was 23.8 percent (previous year: 21.0 percent).

TEUR	Jan-Dec 2007	Jan-Dec 2006
Profit before income tax	102,392	75,583
Income tax expense	(24,324)	(15,904)
Effective tax rate (percent)	23.8	21.0

Notes to the Consolidated Cash Flow Statement

The presentation of the cash flow statement is based on the indirect method. The item funds corresponds to cash and cash equivalents of the balance sheet.

Income taxes paid in the amount of TEUR 22,160 (previous year: TEUR 19,431) are shown as a separate item under operating activities. Interest received and paid is reported under operating activities. In the year under review, cash flows from dividend payments totalled TEUR 21,684 (previous year: TEUR 18,662).

Segment Reporting

Financials are determined and presented for the primary segments EUROPE and the REST of the WORLD as well as NORTH and SOUTH AMERICA, and for the secondary segments CRANES as well as HYDRAULIC SYSTEMS and SERVICES.

The purchasing, manufacturing, and assembling divisions as well as internal holding and internal Group service activities are allocated to the individual product groups and are hence not reported separately.

Primary Segment: Regions

EUROPE and the REST of the WORLD

In these regions all product groups except for telescopic cranes are marketed.

NORTH and SOUTH AMERICA

Cranes and services are available in North and South America, while PALIFT container handling systems and GRAYLER transportable forklifts are also sold in North America. Telescopic cranes also comprise part of the product portfolio in Brazil.

Notes to the Consolidated Financial Statements 2007

TEUR	EUROPE and REST of the WORLD			NORTH and SOUTH AMERICA			Total	Total
	Jan-Dec 2007	Jan-Dec 2006	Jan-Dec 2007	Jan-Dec 2006	Jan-Dec 2007	Jan-Dec 2006		
External sales	621,836	511,904	73,787	73,301	695,623	585,205		
Intra-group sales	26,858	23,593	0	0	26,858	23,593		
Depreciation, amortisation, and impairment of which impairment	13,463 0	13,043 2,148	2,175 0	2,057 0	15,638 0	15,100 2,148		
Write-ups	1,755	0	0	0	1,755	0		
Earnings before interest and taxes (EBIT)	97,793	73,732	1,845	3,294	99,638	77,026		
Income from associated companies	5,755	2,106	0	0	5,755	2,106		
Segment assets of which investments in associated companies	457,081 11,951	347,645 8,054	71,233 0	61,721 0	528,314 11,951	409,366 8,054		
Segment liabilities	174,338	116,994	58,920	50,408	233,258	167,402		
Investments in intangible assets and property, plant, and equipment	77,313	19,885	8,208	2,664	85,521	22,549		

Secondary Segment: Product Groups**CRANES**

The CRANES segment comprises the following product divisions:

- Knuckle boom cranes
- EPSILON – timber and recycling cranes
- Telescopic cranes

HYDRAULIC SYSTEMS and SERVICES

The HYDRAULIC SYSTEMS and SERVICES segment comprises the following product divisions:

- PALIFT – container handling systems
- TAIL LIFT – tailgates
- BISON – aerial work platforms
- CRAWLER – transportable forklifts
- RAILWAY – railway system solutions
- SERVICES

TEUR	CRANES		HYDRAULIC SYSTEMS/SERVICES		Total	
	Jan-Dec 2007	Jan-Dec 2006	Jan-Dec 2007	Jan-Dec 2006	Jan-Dec 2007	Jan-Dec 2006
External sales	510,140	413,180	185,483	172,025	695,623	585,205
Earnings before interest and taxes (EBIT)	99,721	84,384	(83)	(7,358)	99,638	77,026
Segment assets	315,146	243,473	213,168	165,893	528,314	409,366
Investments in intangible assets and property, plant, and equipment	45,587	16,972	39,934	5,577	85,521	22,549

Transfer Pricing

Transfer pricing between the manufacturing plants, the assembly plants, and distribution companies is carried out at calculated budgeted cost plus interest on capital employed.

Notes to the Consolidated Financial Statements 2007

Financial Instruments

The reconciliation of the carrying amounts for each category under IAS 39 to fair values is shown in the following table:

	at amortised cost				at fair value				No financial instrument	
	Carrying amount 31 Dec 2006	Loans and receivables	At amortised cost	Held-to- maturity	Available- for-sale	Hedging derivatives	At fair value through profit or loss	Held-for- trading		Carrying amount of financial instruments 31 Dec 2006
Non-current assets										
Other non-current assets	2,942	2,091	0	0	619	0	0	0	2,710	2,710
Current assets										
Receivables and other current assets	104,004	91,095	0	0	5,009	1,039	0	0	97,143	97,143
Cash and cash equivalents	30,536	0	30,536	0	0	0	0	0	30,536	30,536
Non-current liabilities										
Other non-current liabilities	31,566	31,566	0	0	0	0	0	0	31,566	31,566
Other non-current liabilities	4,174	0	3,594	0	0	0	0	0	3,594	3,594
Current liabilities										
Current financial liabilities	15,241	15,241	0	0	0	0	0	0	15,241	15,241
Current provisions	16,402	0	0	0	0	464	0	0	464	464
Other current liabilities	76,201	0	71,147	0	0	0	0	0	71,147	71,147

at fair value

at amortised cost

TEUR	Carrying amount 31 Dec 2007	Loans and receivables	At amortised cost	Held-to- maturity	Available- for-sale	Hedging derivatives	At fair value through profit or loss	Held-for- trading	Carrying amount of financial instruments 31 Dec 2006	Fair value of financial instruments 31 Dec 2007	No financial instruments
Non-current assets											
Other non-current assets	2,732	1,950	0	0	550	0	0	0	2,500	2,500	23
Current assets											
Receivables and other current assets	133,112	120,770	0	0	82	917	0	0	121,769	121,769	11,34
Cash and cash equivalents	2,559	0	2,559	0	0	0	0	0	2,559	2,559	(
Non-current liabilities											
Non-current financial liabilities	38,315	38,315	0	0	0	0	0	0	38,315	38,315	(
Other non-current liabilities	1,176	0	660	0	0	0	0	0	660	660	51
Current liabilities											
Current financial liabilities	43,598	43,598	0	0	0	0	0	0	43,598	43,598	(
Current provisions	14,063	0	0	0	0	0	0	8	8	8	14,05
Other current liabilities	99,276	0	57,867	0	0	0	0	0	57,867	57,867	41,40

Notes to the Consolidated Financial Statements 2007

Financial Risks

The main focus of the PALFINGER Group, in accordance with its own Treasury Guidelines, is on minimising financial risks, which are individually enumerated in the following.

1. Liquidity Risk

Liquidity risk is the risk to earnings or capital arising from the inability to meet obligations when they come due.

As the Group currently shows a low level of indebtedness, there is only a limited liquidity risk. The existing liquidity requirements can be covered from available liquid funds and credit limits granted by banks.

TEUR	31 Dec 2006	< 1 year	1-5 years	> 5 years
Financial liabilities	46,807	15,241	29,975	1,591
Other liabilities				
Trade payables	56,806	53,759	3,047	0
Liabilities to associated companies	6	6	0	0
Miscellaneous liabilities	23,563	22,436	1,127	0
Total	127,182	91,442	34,149	1,591
TEUR	31 Dec 2007	< 1 year	1-5 years	> 5 years
Financial liabilities	81,913	43,598	36,101	2,214
Other liabilities				
Trade payables	65,036	65,036	0	0
Liabilities to associated companies	888	888	0	0
Miscellaneous liabilities	34,528	33,352	1,176	0
Total	100,452	99,276	1,176	0
	182,365	142,874	37,277	2,214

2. Credit Risk

Credit risk is the risk of loss due to a contracting party's default in payment or non-payment. The Group is counter-acting this risk by establishing internal limits for contracting parties – determined through solvency analyses – and taking out adequate insurance.

The following is a breakdown of trade receivables overdue and receivables from associated companies:

TEUR	31 Dec 2007	31 Dec 2006
Receivables not yet due	100,934	80,412
Receivables overdue		
Overdue for less than 30 days	13,519	9,810
Overdue for more than 30 days but less than 60 days	3,549	2,205
Overdue for more than 60 days but less than 90 days	1,249	735
Overdue for more than 90 days but less than 120 days	507	416
Overdue for more than 120 days	3,467	2,881
	22,291	16,047
Impairment losses	(3,649)	(3,742)
Total	119,576	92,717

When investing money with banks the Group attaches great importance to top international solvency ratings. Credit risk is limited to the items reported in their balance sheets.

3. Foreign Exchange Risk

Foreign exchange risk is a form of risk that arises from the change in price of one currency against another. The value of a financial instrument may be affected by changes in the currency exchange rate.

The Group's global activities account for payment transactions in different currencies. By relocating the value creation, the Group tries as far as possible to minimise the foreign exchange exposure through natural hedges. The remaining foreign exchange exposure is hedged using adequate hedging instruments. Cash flows from operating activities are hedged by means of foreign exchange forwards (cash flow hedges), finance and investments in foreign currencies also by means of foreign exchange forwards (fair value hedges). The Treasury Guidelines adopted by the Management Board specify that financial transactions may only be concluded on the basis of a relevant hedged item. Speculative transactions (i.e. transactions without an underlying operating item) are prohibited.

The Group's foreign exchange positions and hedges are constantly monitored, analysed with regard to the risk sensitivity of the Group, and subject to stress testing. A devaluation of the US dollar as of 31 December 2007 by 10 percent would have decreased equity (presentation of the cash flow hedge) by another TEUR 1,029.

Notes to the Consolidated Financial Statements 2007

4. Interest Rate Risk

Changing interest rates have an impact on the economic value of financial instruments (in particular in case of fixed interest rates) and the net interest rate (income or expense) resulting from these financial instruments. This impact constitutes the interest rate risk in its two forms – risk of change in value and net interest rate risk.

The risk of change in value results in a depreciation of financial assets or an appreciation of financial liabilities. Changing values have a more pronounced impact on fixed interest rates than on variable interest rates.

The net interest rate risk is manifested in higher interest expenses for financial liabilities or low interest income on financial assets. This risk mainly concerns financial instruments with variable (short-term) interest rates.

Both types of interest rate risk are currently monitored. As the Group currently shows a low level of indebtedness, there are only few risk positions. A change in interest rates by 1 percent has an impact on earnings (in terms of EBIT) in the amount of 0.5 percent. The net interest rate risk is currently not hedged on account of its minor impact on the consolidated net profit for the period. The risk of change in value is taken into account by reporting changes in value by writing up financial liabilities and writing down financial assets.

Hedging**Hedging of Future Cash Flows (Cash Flow Hedge)**

From its revenue generated in North America the Group had a US-dollar position that provided the basis for hedging. Cash flows planned for the future are hedged by means of derivative financial instruments. From the wide range of hedging instruments available, the Group decided on foreign exchange forwards. In such a contract the exchange rate for the conversion of two currencies is determined in advance and is thus a suitable tool for reducing this type of exposure, as the result of the underlying transaction runs in the opposite direction of the result of the forward transaction. Assessment and risk analysis of the outstanding hedges are carried out regularly (mark to market).

	Currency	Nominal amount in contractual currency		Mark-to-market valuation in euro	
		31 Dec 2007	31 Dec 2006	31 Dec 2007	31 Dec 2006
Thousand					
Foreign exchange forwards	USD	17,040	26,040	698	1,040
Swaps	USD	0	2,400	0	(5)
Total				698	1,035

The market value of hedges is reported as a cash flow hedge pursuant to IAS 39. Valuation gains or losses as of the balance sheet date are to be directly recognised in equity. As soon as the underlying transactions are carried out, the accumulated gains/losses are reversed from equity to income.

Hedging of Loans (Fair Value Hedge)

In order to hedge its foreign currency loans – granted by PALFINGER AG to two of its Group companies in the respective functional currency of the company concerned – forward exchange sales were concluded which qualify as fair value hedges. In accordance with IAS 39 valuation gains/losses were recognised in income.

Thousand	Currency	Nominal amount in contractual currency		Mark-to-market valuation in euro	
		31 Dec 2007	31 Dec 2006	31 Dec 2007	31 Dec 2006
Swaps	USD	14,500	14,500	207	(383)
	GBP	715	900	12	(76)
Total				219	(459)

Hedging of Funds (Held-for-Trading)

USD swaps which the Group uses for the hedging of funds and which do not meet the criteria of hedge accounting under IAS 39 with regards to documentation and effectiveness are classified as held-for-trading. Changes in the fair values of these derivative financial instruments are recognised in the income statement.

Thousand	Currency	Nominal amount in contractual currency		Mark-to-market valuation in euro	
		31 Dec 2007	31 Dec 2006	31 Dec 2007	31 Dec 2006
Swaps	USD	500	0	(8)	0
Total				(8)	0

Notes to the Consolidated Financial Statements 2007

Other Disclosures

Disclosures of Business Transactions with Related Parties

All transactions with associated companies and with enterprises controlling associated companies were carried out for the provision of goods and services. The associated companies are listed in the attached statement of investments.

The term Key Management comprises the Supervisory and Management Boards of PALFINGER AG. Other related parties primarily include businesses controlled by Key Management and the Palfinger family. Transactions carried out with Key Management and other related parties result from the delivery of goods and provision of consultancy services.

	Associated companies		Key Management		Other		Other
	31 Dec 2007	31 Dec 2006	31 Dec 2007	31 Dec 2006	31 Dec 2007	31 Dec 2006	
TEUR							
Receivables	5,914	2,730	0	0	494	873	
Liabilities	904	6	0	0	10	0	
Revenue	56,245	40,454	0	0	2,687	3,649	
External services	0	0	5	11	58	282	
Materials	3,615	699	0	0	279	550	

Transaction Disclosures in Accordance with Sec. 48d Para. 4 of the Austrian Stock Exchange Act (Börseg)

In accordance with the Group's Compliance Policy the following transactions were reported to the Austrian Financial Market Authority (FMA) and published on the website of PALFINGER AG without delay:

Palfinger Privatstiftung

- Sale of 7,072 shares (28,288 shares after the stock split) at a price of TEUR 1,202 on 4 June 2007
- Acquisition of 2,288 shares at a price of TEUR 83 on 16 July 2007
- Acquisition of 13,000 shares at a price of TEUR 433 on 20 August 2007
- Acquisition of 6,000 shares at a price of TEUR 198 on 29 August 2007
- Acquisition of 28,243 shares at a price of TEUR 952 on 10 September 2007
- Acquisition of 11,757 shares at a price of TEUR 365 on 12 November 2007
- Acquisition of 1,500 shares at a price of TEUR 40 on 20 November 2007
- Wolfgang Anzengruber, CEO
- Acquisition of 40,000 shares at a price of TEUR 394 (share price in accordance with stock option programme of 13 April 2005) on 12 July 2007
- Herbert Ortner, Management Board member
- Acquisition of 2,500 shares at a price of TEUR 79 on 17 August 2007

- *Wolfgang Pilz, Management Board member*
Acquisition of 2,497 shares at a price of TEUR 80 on 17 August 2007
- *Hubert Palfinger, Deputy Chairman of the Supervisory Board*
Acquisition of 2,000 shares at a price of TEUR 66 on 21 August 2007
- Acquisition of 12,000 shares at a price of TEUR 398 on 10 September 2007
- *Alexander Exner, Supervisory Board member*
Acquisition of 2,000 shares at a price of TEUR 53 on 20 November 2007
- Acquisition of 1,000 shares at a price of TEUR 27 on 23 November 2007
- *Hubert Palfinger jun., Supervisory Board member*
Acquisition of 1,625 shares at a price of TEUR 60 on 17 July 2007
- *Hannes Palfinger*
Acquisition of 2,500 shares at a price of TEUR 94 on 17 July 2007
- Acquisition of 1,500 shares at a price of TEUR 50 on 21 August 2007
- Acquisition of 500 shares at a price of TEUR 16 on 9 November 2007
- Acquisition of 500 shares at a price of TEUR 16 on 13 November 2007
- Acquisition of 700 shares at a price of TEUR 19 on 20 November 2007

Other Liabilities and Risks Contingent Liabilities

TEUR	31 Dec 2007	31 Dec 2006
Liabilities on issuing and transferring bills of exchange	0	0
Suretyships, guarantees	0	0
Other contractual liability	932	2,120
Total	932	2,120

Operating Leases

Liabilities for the use of assets not recognised in the balance sheet will presumably amount to TEUR 2,906 (previous year: TEUR 1,077) for the 2008 financial year and TEUR 7,633 (previous year: TEUR 3,967) for the next five years.

Finance Leases

The carrying amounts of property, plant, and equipment leased under finance leasing agreements amounted to TEUR 10,445 (previous year: TEUR 5,156) as of the balance sheet date. The property, plant, and equipment leased are buildings and a company aircraft. The change in comparison to 2006 is, for the most part, attributable to the replacement of the aircraft. The pertaining lease liabilities are carried under financial liabilities in accordance with their durations.

Notes to the Consolidated Financial Statements 2007

TEUR	Minimum lease payments			Present value	
	31 Dec 2007	31 Dec 2006	31 Dec 2007	31 Dec 2006	
Up to one year	1,174	726	702	610	
Between one and five years	5,438	1,778	3,907	1,476	
More than five years	5,660	1,607	964	1,591	
Total	12,272	4,111	5,573	3,677	
Minus any future finance costs	(6,699)	(434)			
Present value of lease payments	5,573	3,677			

Key Events after the Balance Sheet Date

After the end of the 2007 financial year there have been no material post-reporting events which would require disclosure.

Disclosures Concerning Governing Bodies and Employees

Employees

The average number of employees in the Group (excluding apprentices but including the Management Board) during the financial year was 3,860 (previous year: 3,443). At the balance sheet date there were 4,377 Group employees (previous year: 3,569), including the MBB Group.

Supervisory Board

The following individuals were either appointed, or delegated by the Works Council, to serve on the Supervisory Board:

- Alexander Exner, Chairman ^{1) 2)}
- Hubert Palfinger, Deputy Chairman ²⁾
- Hubert Palfinger jun.
- Kurt Stiassny ¹⁾
- Peter R. Scharler
- Alexander Doujak
- Johann Mair (Works Council) ¹⁾
- Alois Weiss (Works Council)
- Gerhard Gruber (Works Council)

The members of the Supervisory Boards received no remuneration for their services.

¹⁾ Member of the Audit Committee

²⁾ Member of the Nomination and Compensation Committee

Management Board

- Wolfgang Anzengruber, CEO
- Eduard Schreiner (up to 31 December 2007)
- Herbert Ortner
- Wolfgang Pilz
- Martin Zehnder (since 1 January 2008)

Total remuneration of the Management Board (excluding stock options) in the 2007 financial year, including ancillary costs, was TEUR 2,097 (previous year: TEUR 1,413) and is broken down as follows:

TEUR	Jan-Dec 2007		Jan-Dec 2006		Jan-Dec 2007		Jan-Dec 2006		Jan-Dec 2007		Jan-Dec 2006	
	Jan-Dec 2007	Jan-Dec 2006	Jan-Dec 2007	Jan-Dec 2006	Jan-Dec 2007	Jan-Dec 2006	Jan-Dec 2007	Jan-Dec 2006	Jan-Dec 2007	Jan-Dec 2006	Jan-Dec 2007	Jan-Dec 2006
Fixed salary	291	287	186	193	209	204	213	208				
Performance-related remuneration	341	169	287	113	285	122	285	117				
Total	632	456	473	306	494	326	498	325				

Following an exercise notice of 2 April 2007 Wolfgang Anzengruber received 10,000 shares of PALFINGER AG in accordance with the stock option programme.

Additional Information Pursuant to Section 245a of the Austrian Business Code (UGB)

At PALFINGER AG expenses for severance and pension payments for members of the Management Board and other executives amounted to TEUR 137 (previous year: TEUR 168), for the remaining employees TEUR 62 (previous year: TEUR 16).

Declaration of Legal Representatives

The Management Board of PALFINGER AG hereby declares that the consolidated financial statements fairly present the actual position of the Group as concerns assets, finances, and earnings and that the consolidated management report gives a fair view of the Group's performance and current state of affairs. The results for the financial year ended on 31 December 2007 do not necessarily allow conclusions to the development of future results.

When preparing the consolidated financial statements the International Financial Reporting Standards (IFRS) were observed and, where necessary, objective estimates were made. The consolidated management report contains an analysis of the Group's assets, finances, and earnings, a description of the material risks and uncertainties the Company is exposed to, and additional disclosures required by the provisions of the Austrian Business Code (UGB).

With resolution adopted by the Annual General Meeting of PALFINGER AG of 28 March 2007 the Supervisory Board appointed Grant Thornton Wirtschaftsprüfungs- und Steuerberatungs-GmbH, Vienna, auditor for the 2007 financial year of PALFINGER AG. This auditing firm has audited the consolidated financial statements and issued the following auditor's opinion. The consolidated financial statements, the consolidated management report, the auditor's report, and the risk management were discussed in depth with the auditors in both the Audit Committee of the Supervisory Board and in the balance sheet meeting of the Supervisory Board as a whole.

Salzburg, 11 February 2008

Wolfgang Anzenrubber m.p.

Herbert Ortner m.p.

Wolfgang Pilz m.p.

Martin Zehnder m.p.

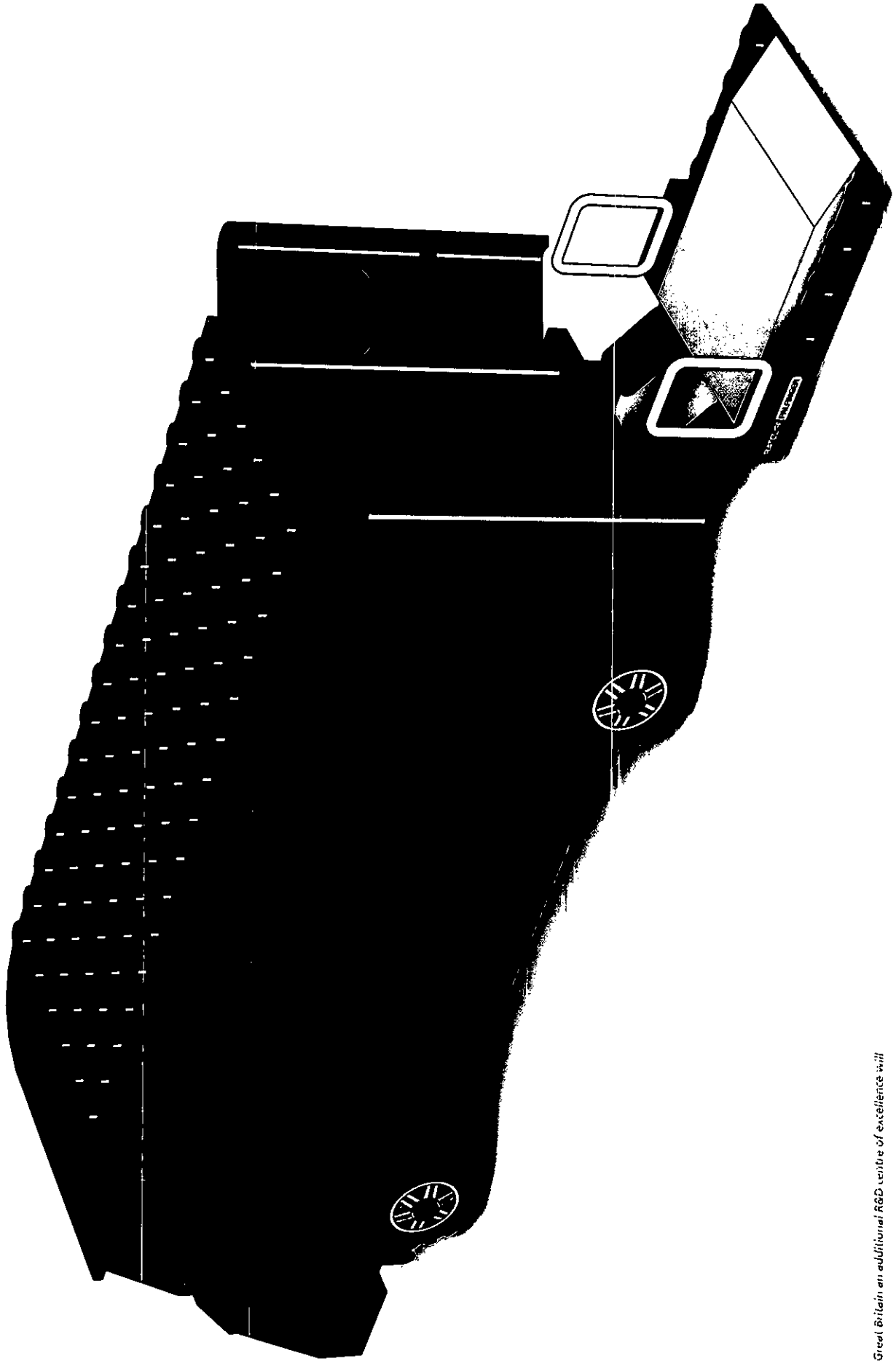

in Great Britain an additional R&D centre of excellence will be implemented for RATCLIFF column and passenger lifts.

Auditor's Report

We have examined the consolidated financial statements of PALFINGER AG, Salzburg, for the financial year from 1 January 2007 to 31 December 2007. This set of consolidated financial statements comprises the consolidated balance sheet as of 31 December 2007, the consolidated income statement, the consolidated cash flow statement, and the consolidated statement of changes in equity for the financial year ending 31 December 2007, as well as a summary of the key valuation and accounting methods applied, and other disclosures contained in the notes.

Responsibility of the Legal Representatives for the Consolidated Financial Statements

The legal representatives of the Company are responsible for the preparation of the consolidated financial statements that convey a fair and true view of the Group's assets, finances, and earnings in accordance with International Financial Reporting Standard (IFRS) as applied in the European Union. The responsibility comprises: the structuring, implementation, and maintenance of an internal controlling system to the extent that this is significant for the compilation of consolidated financial statements and the conveying of a fair and true view of the Group's assets, finances, and earnings, and to the extent that this allows these consolidated financial statements to be free of significant misrepresentations, whether attributable to either intended or unintended errors, the selection of estimates that appear appropriate when considering the overall framework of conditions.

Responsibility of the Auditor

Our responsibility consists in the issuance of an audit opinion, based on our audit, of these consolidated financial statements. We have conducted our audit in accordance with the Austrian legal regulations and the International Standards on Auditing (ISA) issued by the International Auditing and Assurance Standards Board (IAASB) of the International Federation of Accountants (IFAC). These standards require that we plan and perform the audit so as to obtain reasonable assurance that the consolidated financial statements are free of material misstatements.

An audit entails the performance of auditing activities to obtain audit evidence with respect to the amounts and other disclosures in the consolidated financial statements. The selection of auditing activities is at the discretion of the auditor and within the auditor's scope of duty. It takes into account the auditor's assessment of the risk of occurrence of the key misstatements, whether attributable to either intended or unintended errors.

When making these assessments of risk, the auditor takes into account the internal controlling system, to the extent that it is significant for the preparation of consolidated financial statements, and for the conveying of a fair and true view of the Group's assets, finances, and earnings. The auditor does this in order to establish appropriate auditing activities in view of the overall framework of conditions, and not to provide an auditing opinion of the effectiveness of the Group's internal controlling system. The audit also entails the evaluation of the accounting principles applied, and of material estimates made by the legal representatives, as well as an evaluation of the overall adequacy of disclosure on the consolidated financial statements. We are of the opinion that we have obtained sufficient and appropriate auditing evidence that provides our audit with a sufficiently secure basis for issuing an audit assessment.

Audit Opinion

Our audit has led to no reservations. On the basis of information obtained through our audit, the consolidated financial statements are in compliance with legal regulations, and represent a fair and true view of the assets, finances, and earnings of the Group as of 31 December 2007. The results of operations and cash flows of the Group for the business year from 1 January 2007 to 31 December 2007 are in compliance with the International Financial Reporting Standards (IFRS) as applied in the European Union.

Reporting on the Consolidated Management Report

In accordance with Austrian legal regulations, the consolidated management report requires auditing to establish that it harmonises with the consolidated financial statements and does not create a false representation of the Group's position.

In our opinion, the consolidated management report harmonises with the consolidated financial statements.

Vienna, 11 February 2008

Grant Thornton
Wirtschaftsprüfungs- und Steuerberatungs-GmbH

Walter Platzer m.p.
Chartered Accountant, Registered Auditor, Tax Consultant

Report of the Supervisory Board

In the 2007 financial year, the Supervisory Board performed all duties assigned to it by law and by the Company's Articles of Association.

Four Supervisory Board meetings were held, on 26 February 2007, 18 June 2007, 17 September 2007, and 17 December 2007, and attended by the Management Board in the 2007 financial year.

Above and beyond this, the Management Board informed the Supervisory Board regularly, both in writing and verbally, about the course of business and the position of the Company and of the Group companies. The Chairman of the Supervisory Board communicated regularly with the Chairman of the Management Board, also outside the scope of the Supervisory Board meetings, in order to confer with him concerning the Company's strategy, business development, and risk situation.

Besides current developments, the Supervisory Board focused primarily on strategy in the individual divisions, acquisition projects, and on major investment decisions. The Executive Committee and the Nominating Committee and the Remuneration Committee, which are composed of the same members, met at regular intervals during the reporting year. The strategic orientation and further development of the Group were the focus of discussions.

PALFINGER AG's financial statements for the year ended on 31 December 2007 and the management report including the Company's accounting records were audited by Grant Thornton Wirtschaftsprüfungs- und Steuerberatungs-GmbH, Vienna. The audit revealed that the accounting records, the financial statements, and the management report comply with the applicable legal regulations and the provisions of the Articles of Association. The final findings of the audit did not give rise to any objections, allowing an unqualified auditor's opinion to be issued for 2007. This also applies to the consolidated financial statements. The consolidated financial statements prepared in

accordance with IFRS were supplemented by the consolidated management report and additional information in accordance with sec. 245a of the Austrian Business Code (UGB). The Supervisory Board has approved the financial statements for the year ended on 31 December 2007 and the management report for the 2007 financial year, thereby adopting the 2007 financial statements of PALFINGER AG in accordance with sec. 25 para. 2 of the Austrian Companies Act (AktG).

The Supervisory Board has approved the consolidated financial statements of the Company and the consolidated management report prepared in accordance with secs. 244 et seq. of the Austrian Business Code. The Supervisory Board has evaluated and approved the proposal of the Management Board with respect to the distribution of profits for the 2007 financial year.

The Supervisory Board would like to thank and acknowledge the members of the Management Board as well as all staff members of the PALFINGER Group for their outstanding commitment and achievements in the 2007 financial year.

Salzburg, 25 February 2008

Alexander Exner m.p.
Chairman of the Supervisory Board

Definition of Performance Indicators

Capital employed is calculated as

- intangible assets
- plus property, plant, and equipment, shareholdings, net current assets

EVA

- (Economic Value Added) indicates a company's value creation
- Ratio of ROCE
- minus WACC and average capital employed

Free cash flow

- is the net amount of cash available to service internal or external borrowing
- Operating cash flow
- plus interest on debt
- minus tax shield on debt interest payment

Gearing ratio

- is a measure relating to a company's debt
- Ratio of net financial debt and
- equity in percent

NOPLAT

- (Net Operating Profit Less Adjusted Taxes) is composed of
- EBIT
- plus equity earnings
- minus taxes on EBIT

ROCE

- (Return on Capital Employed) shows the rate of return a company generates on capital invested in the enterprise
- Ratio of NOPLAT and
- average capital employed in percent

ROE

- (Return on Equity) is a measure of a company's profitability that presents earnings in relation to equity capital employed
- Ratio of after-tax earnings and
- average equity employed
- minus the dividends paid as a percentage

WACC

- (Weighted Average of Cost of Capital) is a measure of the average cost of capital employed (debt and equity)

Working capital

- is the net surplus of current assets over current liabilities

Austria	PALFINGER AG <ul style="list-style-type: none">· Franz-Wolfram-Scherer-Strasse 24, 5101 Bergheim, Salzburg Palfinger Service- und Beteiligungs-GmbH <ul style="list-style-type: none">· Franz-Wolfram-Scherer-Strasse 24, 5101 Bergheim, Salzburg· Moosmühlstrasse 1, 5203 Köstendorf· Lengau 184, 5211 Friedburg Palfinger Europe GmbH <ul style="list-style-type: none">· Franz-Wolfram-Scherer-Strasse 24, 5101 Bergheim, Salzburg· Moosmühlstrasse 1, 5203 Köstendorf· Lengau 184, 5211 Friedburg
	EPSILON Kran GmbH <ul style="list-style-type: none">· Christophorusstrasse 30, 5061 Elisabethen, Glaserbach STEPA Farmkran Gesellschaft m.b.H. <ul style="list-style-type: none">· Christophorusstrasse 28, 5061 Elisabethen, Glaserbach
Argentina	Palfinger Argentina S.A. <ul style="list-style-type: none">· Av. Corrientes 327, 3° Piso, Buenos Aires
Belgium	MBB INTERLIFT N.V. <ul style="list-style-type: none">· Industrielaan 4, 3e Industriezone, 9320 Erembodegem
Brazil	Madal Palfinger S.A. <ul style="list-style-type: none">· Rua Flavio Francisco Bellini 350, CEP 95098-170, Caxias do Sul
Bulgaria	Palfinger Produktionstechnik Bulgaria EOOD <ul style="list-style-type: none">· 5980 Cherven Brjag· 8672 Tenevo
Canada	Palfinger Inc. <ul style="list-style-type: none">· 7942 Dorchester Road, Niagara Falls, Ontario L2E 6V6

Corporate Locations

China	<p>Palfinger (Shenzhen) Ltd.</p> <ul style="list-style-type: none"> Block 5, Northern Yongfa Technological Park, District B, Chuandong Industrial Park, Dao Yan Chuan Chaoyang Road, Song Gang Street, Bao An District, Shenzhen
Croatia	<p>PIR metal d.o.o.</p> <ul style="list-style-type: none"> Ivana Zavidica 27, 51000 Rijeka Lučicka Cesta 8B, Lučice, 51300 Delnice
Germany	<p>Palfinger GmbH</p> <ul style="list-style-type: none"> Feldkirchener Feld 1, 83404 Ainring <p>Bison Palfinger GmbH</p> <ul style="list-style-type: none"> Äussere Bautzner Strasse 47, 02708 Löbau <p>MBB LIFTSYSTEMS AG</p> <ul style="list-style-type: none"> Fockestrasse 53, 27777 Ganderkesee, Hoykenkamp
France	<p>Financière Palfinger S.A.S.</p> <ul style="list-style-type: none"> 29A, Avenue des Tourondes, 82300 Caussade <p>Guima Palfinger S.A.S.</p> <ul style="list-style-type: none"> 29A, Avenue des Tourondes, 82300 Caussade <p>Guima France S.A.S.</p> <ul style="list-style-type: none"> 29A, Avenue des Tourondes, 82300 Caussade <p>Palfinger France S.A.</p> <ul style="list-style-type: none"> ZA Les Bassaux – BP 73, 26802 Étoile sur Rhône Cedex <p>Palfinger Paris Sud S.C.I.</p> <ul style="list-style-type: none"> ZA Les Bassaux – BP 73, 26802 Étoile sur Rhône Cedex <p>Mesle Equipement S.A.S.</p> <ul style="list-style-type: none"> Za de la Longueraie, 56140 Saint Abraham

	Palfinger Service S.A.S. <ul style="list-style-type: none">· Avenue Condorcet, 91240 Saint Michel
	MBB INTER S.A.S. <ul style="list-style-type: none">· Rue de l'Eglise, 61310 Silly en Gouffern
Great Britain	Ratcliff Palfinger Ltd. <ul style="list-style-type: none">· Bessemer Road, Welwyn Garden City, Herts AL7 1ET
	MBB LIFTSYSTEMS Ltd. <ul style="list-style-type: none">· Trafalgar House, 712 London Road, West Thurrock, Essex RM20 3NE
Italy	Palfinger Gru Idrauliche S.r.l. <ul style="list-style-type: none">· Via Dante Aleghieri 50, 42023 Cadelbosco di Sopra (RE)
Singapore	Palfinger Asia Pacific Pte. Ltd. <ul style="list-style-type: none">· 3 International Business Hub #07-01, Nordic European Center, Singapore 609927
Slovakia	MBB HUBFIX s.r.o. <ul style="list-style-type: none">· Tovarenska 14, 81571 Bratislava
Slovenia	Palfinger proizvodnja d.o.o. <ul style="list-style-type: none">· Jaskova 18, 2001 Maribor
South Africa	Palfinger Southern Africa (Pty) Ltd. <ul style="list-style-type: none">· 1 Nguni Drive, Longmeadow West, 1609 Edenvale
USA	Palfinger USA, Inc. <ul style="list-style-type: none">· 1775 S. Seneca CO. RD. 1, Tiffin, Ohio 44883 Tiffin Loader Crane Company <ul style="list-style-type: none">· 1775 S. Seneca CO. RD. 1, Tiffin, Ohio 44883 INTERLIFT inc. <ul style="list-style-type: none">· 15939 Piuma Avenue, Cerritos, California 90703

Imprint

PALFINGER AG
Franz-Wolfram-Scherer-Strasse 24
5101 Berghheim, Salzburg
Austria

Investor Relations
Hannes Roither
Company Spokesperson
Phone +43 662 4684-2260
Fax +43 662 4684-2280
h.roither@palfinger.com
www.palfinger.com



Daniela Werdecker
Corporate Communications
Phone +43 662 4684-2219
Fax +43 662 4684-2280
d.werdecker@palfinger.com

Consulting
Scholdan & Company

Design
Rahofer Werbeagentur

Pictures
Vienna Paint

Minimal arithmetical differences may arise from the application of commercial rounding to individual items and percentages in the Annual Report.
The English translation of the PALFINGER report is for convenience. Only the German text is binding.

No liability is assumed for any typographical or printing errors.

The products illustrated are not part of the LEGO® range but were created by PALFINGER AG from LEGO elements as special sets for the Group's Annual Report 2007.
We would like to point out that these models are not available for purchase and that the LEGO Group has not marketed or produced these products.

PALFINGER AG

100% | Palfinger Service- und Beteiligungs-GmbH

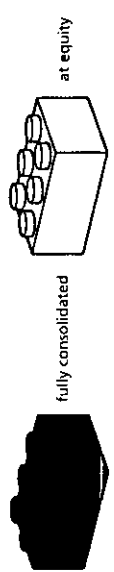
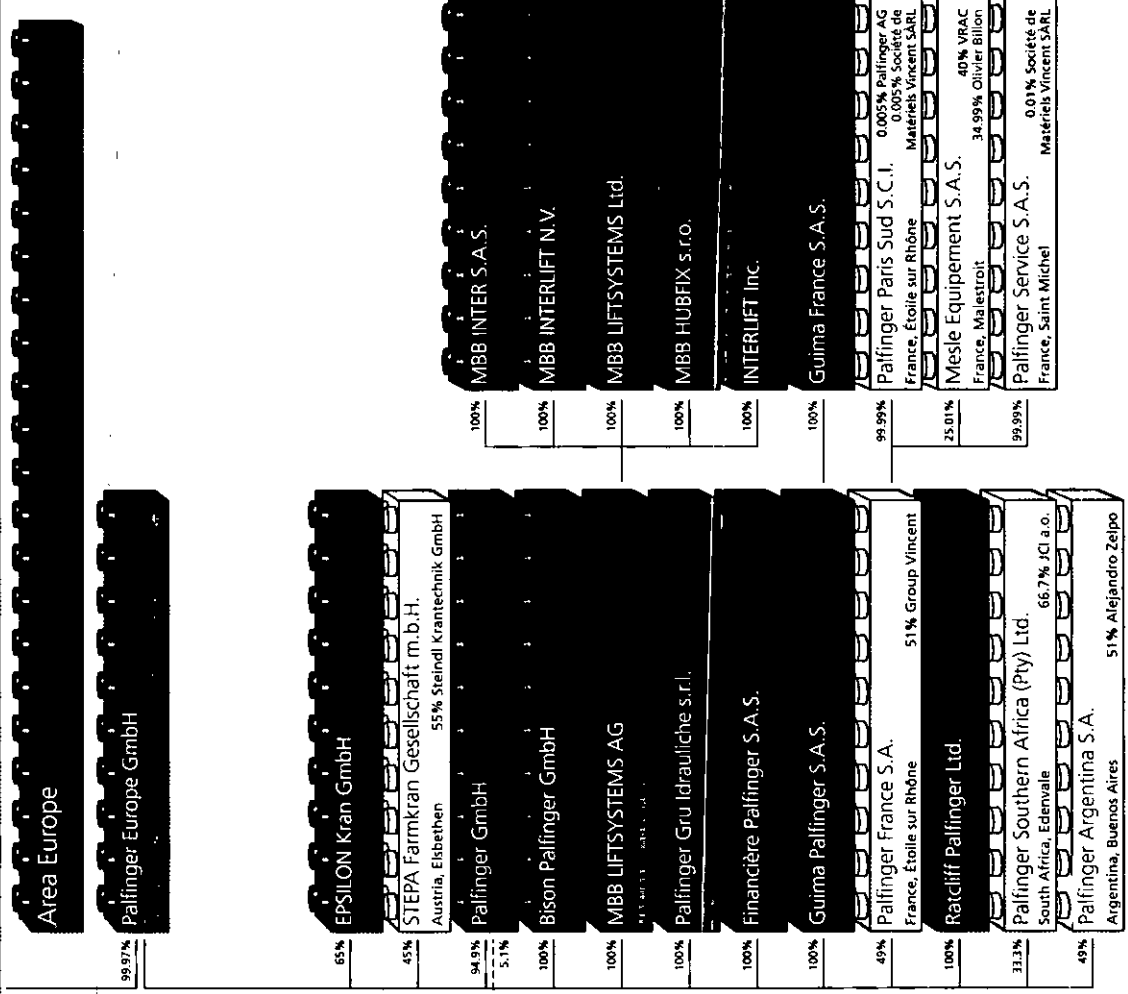

non-consolid

PALFINGER

PALFINGER AG
Franz-Wolfram-Schärer-Strasse 24
5101 Bergheim, Salzburg, AUSTRIA
www.palfinger.com

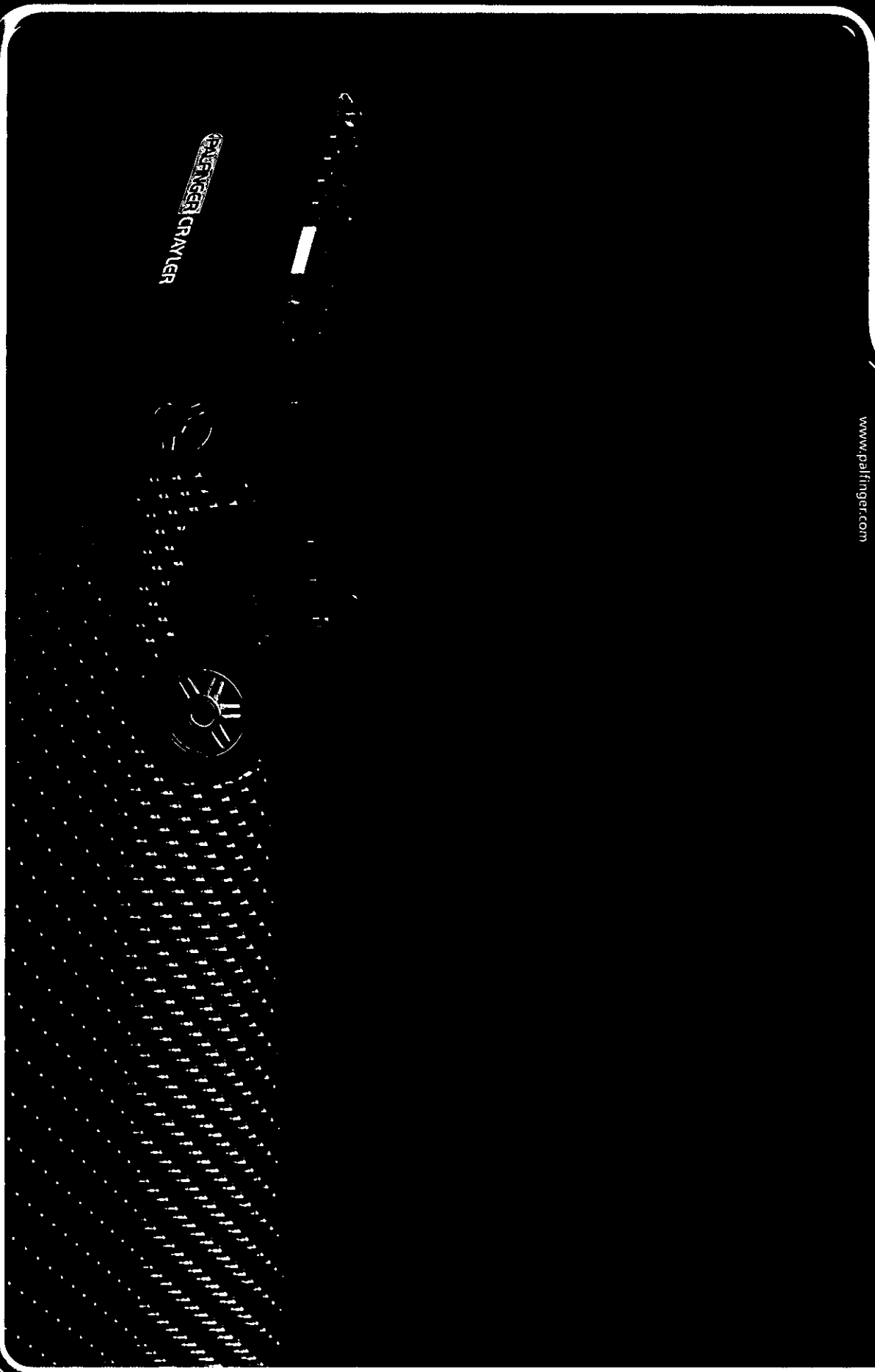

-----BEGIN PRIVACY-ENHANCED MESSAGE-----

Proc-Type: 2001,MIC-CLEAR

Originator-Name: webmaster@www.sec.gov

Originator-Key-Asymmetric:

MFgwCgYEVQgBAQICaf8DSgAwRwJAW2sNKK9AVtBzYZmr6aGj1WyK3XmZv3dTINen

TWSM7vrzLADbmYQaionwg5sDW3P6oaM5D3tdezXMm7z1T+B+twIDAQAB

MIC-Info: RSA-MD5,RSA,

KskPua8vGVy+Qf7DeW9aHeIgBKzYyw2T/37xk7z3BeU2420/udo9hDeJkFKyGWve

lucONb3jh7bqufmlNKuAhA==

RECEIVED
2006 MAR 31 P 1:23
OFFICE OF INTERNATIONAL
CORPORATE FINANCE

<SEC-DOCUMENT>9999999997-06-017860.txt : 20060503

<SEC-HEADER>9999999997-06-017860.hdr.sgml : 20060503

<ACCEPTANCE-DATETIME>20060503101123

<PAPER>

ACCESSION NUMBER: 9999999997-06-017860

CONFORMED SUBMISSION TYPE: ARS

PUBLIC DOCUMENT COUNT: 1

CONFORMED PERIOD OF REPORT: 20051231

FILED AS OF DATE: 20060502

DATE AS OF CHANGE: 20060503

EFFECTIVENESS DATE: 20060502

FILER:

COMPANY DATA:

COMPANY CONFORMED NAME:

PALFINGER AG

CENTRAL INDEX KEY:

0001310883

STANDARD INDUSTRIAL CLASSIFICATION:

UNKNOWN SIC - 8880 [8880]

FILING VALUES:

FORM TYPE: ARS

SEC ACT: 1934 Act

SEC FILE NUMBER: 082-34843

FILM NUMBER: 06013025

BUSINESS ADDRESS:

STREET 1: FRANZ-WOLFRAM-SCHERER-STRABE24-28

CITY: A-5101 BERGHEIM/SALZBURG

STATE: C4

ZIP: 00000

MAIL ADDRESS:

STREET 1: FRANZ-WOLFRAM-SCHERER-STRABE24-28

CITY: A-5101 BERGHEIM/SALZBURG

STATE: C4

ZIP: 00000

</SEC-HEADER>

<DOCUMENT>

<TYPE>ARS

<SEQUENCE>1

<FILENAME>9999999997-06-017860.paper

<DESCRIPTION>AUTO-GENERATED PAPER DOCUMENT

<TEXT>

This document was generated as part of a paper submission.

Please reference the Document Control Number 06013025 for access to the original.

</TEXT>

</DOCUMENT>

</SEC-DOCUMENT>

-----END PRIVACY-ENHANCED MESSAGE-----



Adhoc - INFORMATION

RECEIVED
2008 MAR 31 P 1:23
OFFICE OF INTERNATIONAL
CORPORATE FINANCE

PALFINGER AG plant Einziehung eigener Aktien

- ◆ Derzeit 1.805.000 eigene Aktien im Besitz der Gesellschaft
- ◆ Hauptversammlung wird über Einziehung von 1.405.000 Stück und entsprechende Herabsetzung des Grundkapitals abstimmen

Bergheim/Salzburg, am 25. Februar 2008

Die PALFINGER AG verfügt derzeit über 1.805.000 Stück eigene Aktien, die im Rahmen eines Aktienrückkaufprogramms bis zum Jahr 2003 erworben wurden. Der durchschnittliche Ankaufskurs betrug 4,60 EUR. Zwecks Bereinigung der Kapitalstruktur plant die Gesellschaft nun, den Großteil dieser Aktien einzuziehen. Eine Anzahl von 400.000 Stück soll zur Verwendung im Rahmen von Aktienoptionsprogrammen behalten werden.

Der Vorstand der PALFINGER AG wird der ordentlichen Hauptversammlung am 26. März 2008 daher nach bereits erfolgter Zustimmung des Aufsichtsrates die Einziehung von 1.405.000 Stück eigenen Aktien sowie die damit verbundene Herabsetzung des Grundkapitals von 37.135.000 EUR um 1.405.000 EUR auf 35.730.000 EUR gemäß § 192 Abs 3 Z 2 AktG iVm § 192 Abs 4 AktG zur Genehmigung vorlegen. Es ist geplant, den Einzug der eigenen Aktien im Laufe des Jahres 2008 durchzuführen.

Rückfragehinweis:

Hannes Roither, PALFINGER AG
Konzernsprecher
Tel. +43 662 46 84-2260
h.roither@palfinger.com

Anton Graf, PALFINGER AG
Investor Relations
Tel. +43 662 46 84-2275
a.graf@palfinger.com

Text und entsprechendes Bildmaterial stehen im Pressecorner unserer Internetseite www.palfinger.com zum Download zur Verfügung. Eine umfassende Bild- und Presstextdatenbank bietet Ihnen außerdem das PALFINGER EXTRANET. Registrieren Sie sich für dieses kostenlose Service unter <http://extranet.palfinger.com>

PALFINGER AG plans to cancel own shares

- ◆ The Company currently holds 1,805,000 own shares
- ◆ The Annual General Meeting will vote on the cancellation of 1,405,000 shares and a subsequent reduction of the share capital

Bergheim, Salzburg, 25 February 2008

PALFINGER AG currently holds 1,805,000 own shares acquired under the share repurchase scheme until 2003. The average share purchase price was EUR 4.60. In order to adjust its capital structure, the Company is now planning to cancel the majority of these shares. It is intended to retain 400,000 shares for the purposes of stock option programmes.

After having obtained the approval of the Supervisory Board, the Management Board of PALFINGER AG will therefore propose to the Annual General Meeting of 26 March 2008 to approve the cancellation of 1,405,000 own shares and a subsequent reduction of the Company's share capital by EUR 1,405,000, from EUR 37,135,000 to EUR 35,730,000, in accordance with sec. 192 para. 3 (2) in conjunction with sec. 192 para. 4 of the Austrian Companies Act (AktG). The Company intends to implement the cancellation of its own shares during 2008.

For further information please contact:
Hannes Roither, PALFINGER AG
Company Spokesperson
Phone +43 662 46 84-2260
h.roither@palfinger.com

Anton Graf, PALFINGER AG
Investor Relations
Tel. +43 662 46 84-2275
a.graf@palfinger.com

Both text and pictures are available for download in the press corner of our website at www.palfinger.com. An extensive database of press documents and pictures can also be found at the PALFINGER EXTRANET. Please register for this free service at <http://extranet.palfinger.com>

PALFINGER baut Erfolgskurs weiter aus

- ◆ Neuerlich Rekordumsatz und -ergebnis im Geschäftsjahr 2007
- ◆ Umsatz um 18,9 Prozent, EBIT überproportional um 29,4 Prozent gesteigert
- ◆ Akquisition von MBB wird Konzernumsatz 2008 um rund 10 Prozent erhöhen
- ◆ Fortsetzung des Wachstumskurses

in Mio EUR	2007	%	2006	2005
Umsätze	695,6	+ 18,9 %	585,2	520,0
EBITDA	115,3	+ 25,1 %	92,1	77,5
Operatives Ergebnis (EBIT)	99,6	+ 29,4 %	77,0	65,1
EBIT-Marge	14,3 %	–	13,2 %	12,5 %
Konzernergebnis	74,0	+ 30,6 %	56,6	48,1
Gewinn je Aktie in EUR ¹⁾	2,09	+ 30,6 %	1,60	1,37
Dividende je Aktie in EUR ¹⁾	0,70 ²⁾	+ 27,3 %	0,55	0,45

1) Vorjahreszahlen entsprechend Aktiensplit adaptiert

2) Vorschlag an die Hauptversammlung

Bergheim/Salzburg, am 26. Februar 2008

Die PALFINGER Gruppe erzielte im Geschäftsjahr 2007 erneut Rekordergebnisse. Sowohl Umsatz und Ergebnis als auch die wesentlichen Kennzahlen konnten auf Basis enorm starker Nachfrage und damit verbunden hoher Kapazitätsauslastung erneut verbessert werden.

Der Umsatz stieg auf 695,6 Mio EUR und lag somit um 18,9 Prozent über dem Vergleichswert des Vorjahres von 585,2 Mio EUR. Das EBIT erhöhte sich um 29,4 Prozent auf 99,6 Mio EUR nach 77,0 Mio EUR im Jahr 2006. Die EBIT-Marge betrug 14,3 Prozent nach 13,2 Prozent im Vorjahr und erreichte damit den höchsten Wert in der Unternehmensgeschichte. Der ROCE mit 25,7 Prozent unterstreicht die Profitabilität von PALFINGER.

Das Eigenkapital erhöhte sich gegenüber dem Vorjahr von 242,0 Mio EUR um 21,9 Prozent auf 295,1 Mio EUR, die Eigenkapitalquote beträgt 55,8 Prozent. Die Gearing Ratio erhöhte sich bedingt durch den gestiegenen Finanzmittelbedarf im Zuge des umfangreichen Investitionsprogramms und durch die getätigten Akquisitionen, liegt jedoch mit 26,7 Prozent nach 4,2 Prozent im Vorjahr immer noch auf sehr niedrigem Niveau.

Der Cashflow aus dem operativen Bereich belief sich im Geschäftsjahr 2007 auf 53,0 Mio EUR nach 59,5 Mio EUR im Vorjahr. Bedingt durch das hohe Investitionsvolumen hat sich der Free Cashflow im Geschäftsjahr 2007 um 66,9 Mio EUR auf – 23,2 Mio EUR verringert.

Mit der Übernahme der deutschen MBB LIFTSYSTEMS AG, eines führenden Herstellers für Ladebordwände, setzte PALFINGER im 4. Quartal 2007 einen weiteren bedeutenden Schritt in seiner Internationalisierungs- und Diversifikationsstrategie. Der Konzernumsatz wird sich durch diesen Zukauf um knapp 10 Prozent erhöhen.

PALFINGER geht für die kommenden Jahre von einem weiterhin starken Marktumfeld aus, partiell schwächere Märkte sollten dabei durch stark wachsende osteuropäische Märkte kompensiert werden. Auf dieser Basis wird der strategische Schwerpunkt ab 2008 verstärkt auf den Auf- bzw. Ausbau strategisch wichtiger Areas und Produktdivisionen gelegt. PALFINGER wird dafür einen eigenen Bereich „VENTURES“ schaffen. Die Segmentberichterstattung wird daher ab dem 1. Quartal 2008 adaptiert, künftig wird nach den drei Segmenten KRANE, HYDRAULISCHE SYSTEME und SERVICES sowie VENTURES berichtet.

Das Management erwartet, dass die Marktentwicklung im Jahr 2008 die Fortsetzung des profitablen Wachstumskurses unterstützen und sicherstellen wird.

Rückfragehinweis:
Hannes Roither, PALFINGER AG
Konzernsprecher
Tel. +43 662 46 84-2260
h.roither@palfinger.com

Anton Graf, PALFINGER AG
Investor Relations
Tel. +43 662 46 84-2275
a.graf@palfinger.com

Text und entsprechendes Bildmaterial stehen im Pressecorner unserer Internetseite www.palfinger.com zum Download zur Verfügung. Eine umfassende Bild- und Presstextdatenbank bietet Ihnen außerdem das PALFINGER EXTRANET. Registrieren Sie sich für dieses kostenlose Service unter <http://extranet.palfinger.com>

PALFINGER extended its strategy for success

- ◆ Record revenues and earnings once again reported in the 2007 financial year
- ◆ Revenue increased by 18.9 percent, EBIT rose more than expected by 29.4 percent
- ◆ Acquisition of MBB will increase Group revenue for 2008 by around 10 percent
- ◆ The Group continued to pursue its growth strategy

in million EUR	2007	%	2006	2005
Revenue	695.6	+ 18.9%	585.2	520.0
EBITDA	115.3	+ 25.1%	92.1	77.5
EBIT	99.6	+ 29.4%	77.0	65.1
EBIT margin	14.3%	–	13.2%	12.5%
Consolidated net profit for the period	74.0	+ 30.6%	56.6	48.1
Earnings per share in EUR ¹⁾	2.09	+ 30.6%	1.60	1.37
Dividend per share in EUR ¹⁾	0.70 ²⁾	+ 27.3%	0.55	0.45

1) Previous year's figures converted pursuant to stock split

2) Proposal to the Annual General Meeting

Bergheim, Salzburg, 26 February 2008

The PALFINGER Group once again achieved record results in the 2007 financial year. On the basis of enormous demand and the consequential high capacity utilisation, PALFINGER succeeded in improving both revenues and earnings, as well as its key performance indicators.

Revenue rose to EUR 695.6 million, which is 18.9 percent above the figure of EUR 585.2 million for the same period of the previous year. EBIT increased by 29.4 percent to EUR 99.6 million, up from EUR 77.0 million in 2006. The EBIT margin amounted to 14.3 percent as compared to 13.2 percent in the previous year, reaching the highest level ever achieved in the history of the Company. ROCE was 25.7 percent, highlighting the profitability of PALFINGER.

Equity increased by 21.9 percent as compared to the previous year, from EUR 242.0 million to EUR 295.1 million, the equity ratio amounted to 55.8 percent. The gearing ratio went up due to the need for increased funds generated by the comprehensive investment programme and the acquisitions made by the Company, but at 26.7 percent, up from 4.2 percent in the previous year, it is still at a very low level.

In the 2007 financial year the cash flow from operating activities amounted to EUR 53.0 million, compared to EUR 59.5 million in the previous year. As a consequence of the high investment volume the free cash flow decreased by EUR 66.9 million to EUR – 23.2 million during the 2007 financial year.

With the take-over of the German company MBB LIFTSYSTEMS AG, one of the world's leading suppliers of tail lifts, in the fourth quarter 2007, PALFINGER took another important

step towards the fulfilment of its internationalisation and diversification strategy. As a result of this take-over Group revenue will rise by slightly under 10 percent.

For the years to come PALFINGER proceeds from the assumption of a continued strong market environment, with partially weaker markets being compensated by the strongly growing markets in Eastern Europe. This is the basis on which, from 2008 onwards, the Company will be placing its strategic focus increasingly on the development and expansion of areas and product divisions of strategic importance. To this end, PALFINGER will set up a separate business segment referred to as VENTURES. Segment reporting will be changed accordingly and starting from the first quarter 2008 PALFINGER will break down its reporting into the following three segments: CRANES, HYDRAULIC SYSTEMS and SERVICES, and VENTURES.

Management expects that the development of the market in 2008 will support and ensure the profitable growth strategy.

For further information please contact:
Hannes Roither, PALFINGER AG
Company Spokesperson
Phone +43 662 46 84-2260
h.roither@palfinger.com

Anton Graf, PALFINGER AG
Investor Relations
Tel. +43 662 46 84-2275
a.graf@palfinger.com

Both text and pictures are available for download in the press corner of our website at www.palfinger.com. An extensive database of press documents and pictures can also be found at the PALFINGER EXTRANET. Please register for this free service at <http://extranet.palfinger.com>

END