



**SATS**



28 December 2004

(Exemption No: 82-5117)

U.S. Securities and Exchange Commission  
Division of Corporation Finance  
Office of International Corporate Finance  
450<sup>th</sup> Fifth Street, N.W.  
Washington D.C. 20549  
United States of America

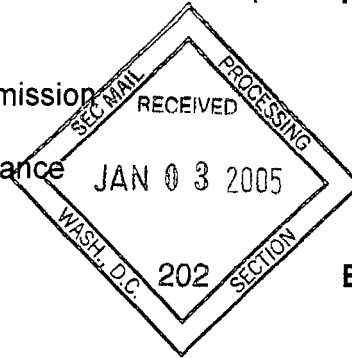

**BY COURIER**

Ladies and Gentlemen

**SUPPL**

**SINGAPORE AIRPORT TERMINAL SERVICES LIMITED**

We enclose 2 bound documents containing copies of Company announcements made pursuant to the Listing Rules of the Singapore Exchange Securities Trading Limited ("SGX-ST"), and filings with the Singapore Accounting & Corporate Regulatory Authority under the Singapore Companies Act (Cap. 50), as per attached lists, made by Singapore Airport Terminal Services Limited ("SATS") up to 21 December 2004.

Yours truly

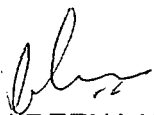
  
**SHIREENA WOON**  
Manager (Legal)

**PROCESSED**  
JAN 12 2005  
J. WONG

encl

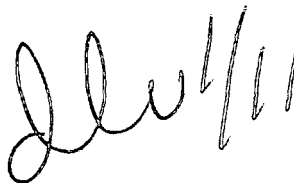



# SGX. Tomorrow's Market, Today

I want to go to .....

Prices | Products/Services | Listed Companies | Our Shareholders | Regulation | About SGX



Home » Listed Companies » Announcements

## Announcements

- New Listings
- Annual Report/Fin. Report
- Company's All-in-One Info
- Research Reports
- AGM Schedules
- Prospectus/Circulars
- Announcements
- Stock/Indices List
- ISIN Code Download
- Corporate Info
- Corporate Action
- Warrants
- Tax Incentive Schemes
- Market Cap
- Sharebuyback Form

Announcements from 1 November 2004	
View Results By	
<b>By Date (Recent Announcements)</b>	<b>By Company Name</b>
<b>By Category</b>	<b>By Category</b>

Announcements before 1 November 2004	
View Results By	
<b>By Date (Recent Announcements)</b>	<b>By Company Name</b>
<b>By Category</b>	<b>By Category</b>

### Listed Companies' Announcements by Company Name :

A B C D E F G H I J K L M N O P Q R S T U V W X Y Z 0-9

In addition to the Web Site Terms and Conditions of Use and the disclaimer found therein, please take note that the information contained in these announcements is sent to SGX electronically by listed companies and SGX does not verify the same. Results based announcements are available for up to 1 year; other announcements are available for 3 months. Not all announcements may be listed here.

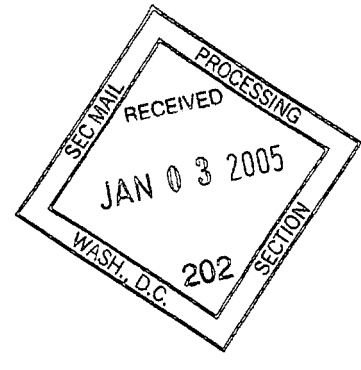

▼ SINGAPORE AIRPORT TRML SVCSLTD

- Dec 15 2004 MISCELLANEOUS :: SATS OPERATING DATA FOR NOVEMBER 2004
- Nov 17 2004 MISCELLANEOUS :: OPERATING DATA FOR OCTOBER 2004
- Nov 03 2004 MISCELLANEOUS :: SLIDES OF RESULTS BRIEFING TO ANALYSTS/MEDIA ON 2ND QUARTER FY04-05 FINANCIAL PERFORMANCE
- Oct 28 2004 Financial Statements for the Second Quarter and Half Year ended 30 September 2004
- Oct 28 2004 NEWS RELEASE : SECOND QUARTER REVENUE INCREASES WITH OPERATING PROFIT UNDER PRESSURE
- Oct 25 2004 CHANGES TO BOARD COMMITTEES
- Oct 14 2004 Operating Data for September 2004



# SGX. Tomorrow's Market, Today

Prices | Products/Services | Listed Companies | Our Shareholders | Regulation | About SGX

I want to go to .....

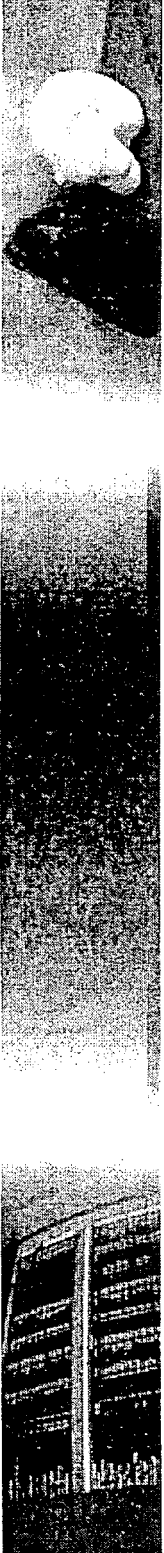

Home » Listed Companies » Announcements

## Announcements

- New Listings
- Annual Report/Fin. Report
- Company's All-In-One Info

- Research Reports
- AGM Schedules
- Prospectus/Circulars
- Announcements

- Stock/Indices List
- ISIN Code Download
- Corporate Info
- Corporate Action

- Warrants
- Tax Incentive Schemes
- Market Cap
- Sharebuyback Form

Announcements from 1 November 2004		
View Results By		
<a href="#">By Date (Recent Announcements)</a>	<a href="#">By Company Name</a>	<a href="#">By Category</a>

Listed Companies' Announcements by Company Name :

A B C D E F G H I J K L M N O P Q R S T U V W X Y Z 0-9

Announcements before 1 November 2004		
View Results By		
<a href="#">By Date (Recent Announcements)</a>	<a href="#">By Company Name</a>	<a href="#">By Category</a>

Printer-Friendly Version

### Miscellaneous

\* Asterisks denote mandatory information

Name of Announcer *	SINGAPORE AIRPORT TERMINAL SERVICES LIMITED
Company Registration No.	197201770G
Announcement submitted on behalf of	SINGAPORE AIRPORT TRML SVCSLTD
Announcement is submitted with respect to *	SINGAPORE AIRPORT TRML SVCSLTD
Announcement is submitted by *	Annabelle Yip Wai Ping
Designation *	Company Secretary
Date & Time of Broadcast	15-Dec-2004 18:43:52
Announcement No.	00086

>> **Announcement Details**

The details of the announcement start here ...

Announcement Title \*  
SATS OPERATING DATA FOR NOVEMBER 2004

Description

**Attachments:**

 SATS-OperatingData-Nov2004.pdf  
 Total size = **68K**  
 (2048K size limit recommended)

[Previous Announcement](#)   [Next Announcement](#)

All Rights Reserved. Copyright ( ) 2003. Singapore Exchange Ltd. Company Reg. No. 199904940D  
2 Shenton Way, #19-00 SGX Centre 1, Singapore 068804. Tel: (65) 6236 8888 Fax: (65) 6535 6994



This is the SATS operating data for November 2004:

	November 2004	November 2003	% change
Unit Services Handled ('000)	6.59	6.26	+ 5.4
Flights Handled ('000)	6.41	5.80	+ 10.4
Cargo/Mail Processed ('000 tonnes)	119.73	122.95	- 2.6
Passengers Handled ('M)	2.23	2.06	+ 8.5
Unit Meals Produced ('M)	1.64	1.48	+ 11.1
Gross Meals Produced ('M)	2.08	1.88	+ 10.7

Note:

- \* unit services & flights handled - relate to Apron handling
- \*\* unit services represent workload handled by Apron staff - whereby each different aircraft/flight type (e.g. B744, A310, etc) is given a different unit service weightage factor.
- \*\*\* unit meals represent workload handled by Catering staff - whereby each meal type (e.g. dinner, lunch, etc) is given a different unit meal weightage factor.

Commentary:

All operating indices except for cargo & mail processed showed improvements in November 2004 compared to the same period last year. Cargo & mail processed showed a slight dip of 2.6%.

Issued by:  
Investor Relations Dept  
Singapore Airport Terminal Services Ltd (SATS)  
Tel: 65-65418153  
Fax: 65-65418154



# SGX. Tomorrow's Market, Today

I want to go to .....

Prices | Products/Services | Listed Companies | Our Shareholders | Regulation | About SGX

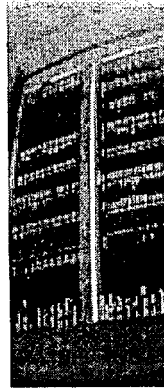

Home » Listed Companies » Announcements

- New Listings
- Annual Report/Fin. Report
- Company's All-in-One Info
- Research Reports
- AGM Schedules
- Prospectus/Circulars

## Announcements

View Results By		
By Date (Recent Announcements)	By Company Name	By Category

Listed Companies' Announcements by Company Name :

A B C D E F G H I J K L M N O P Q R S T U V W X Y Z 0-9

- Corporate Info
- Corporate Action
- Warrants
- Tax Incentive Schemes
- Market Cap
- Sharebuyback Form

Printer-Friendly Version

Miscellaneous	
* Asterisks denote mandatory information	
Name of Announcer *	SINGAPORE AIRPORT TERMINAL SERVICES LIMITED
Company Registration No.	197201770G
Announcement submitted on behalf of	SINGAPORE AIRPORT TRML SVCS LTD
Announcement is submitted with respect to *	SINGAPORE AIRPORT TRML SVCS LTD
Announcement is submitted by *	ANNABELLE YIP
Designation *	COMPANY SECRETARY

Date & Time of Broadcast	17-Nov-2004 17:30:17
Announcement No.	00031

**>> Announcement Details**  
The details of the announcement start here ...

Announcement Title \*  
Operating Data for October 2004

Description

**Attachments:**  
[SATS-OperatingData-Oct2004.pdf](#)  
Total size = **67K**  
(2048K size limit recommended)

[Previous Announcement](#)   [Next Announcement](#)

All Rights Reserved. Copyright ( ) 2003, Singapore Exchange Ltd. Company Reg. No. 199904940D,  
2 Shenton Way, #19-00 SGX Centre 1, Singapore 068804. Tel: (65) 6236 8888 Fax: (65) 6535 6994





This is the SATS operating data for October 2004:

	October 2004	October 2003	% change
Unit Services Handled ('000)	6.71	6.08	+ 10.3
Flights Handled ('000)	6.52	5.59	+ 16.6
Cargo/Mail Processed ('000 tonnes)	130.30	128.73	+ 1.2
Passengers Handled ('M)	2.13	1.97	+ 7.7
Unit Meals Produced ('M)	1.59	1.43	+ 10.8
Gross Meals Produced ('M)	1.99	1.80	+ 10.2

Note:

- \* unit services & flights handled - relate to Apron handling
- \*\* unit services represent workload handled by Apron staff - whereby each different aircraft/flight type (e.g. B744, A310, etc) is given a different unit service weightage factor.
- \*\*\* unit meals represent workload handled by Catering staff - whereby each meal type (e.g. dinner, lunch, etc) is given a different unit meal weightage factor.

Commentary:

All operating indices continued to show significant increases in October 2004 compared with the corresponding month a year ago. October 2004 volumes for cargo/mail and flights handled are at their highest levels for the past 3 years and 21 months respectively.

Issued by:  
Investor Relations Dept  
Singapore Airport Terminal Services Ltd (SATS)  
Tel: 65-65418153  
Fax: 65-65418154



# SGX. Tomorrow's Market, Today

Prices | Products/Services | Listed Companies | Our Shareholders | Regulation | About SGX

I want to go to .....



Home » [Listed Companies](#) » [Announcements](#)

## Announcements

- New Listings
- Annual Report/Fin. Report
- Company's All-In-One Info

- Research Reports
- AGM Schedules
- Prospectus/Circulars
- Announcements

- Stock/Indices List
- ISIN Code Download
- Corporate Info
- Corporate Action

- Warrants
- Tax Incentive Schemes
- Market Cap
- Sharebuyback Form

Announcements from 1 November 2004		
View Results By		
By Date (Recent Announcements)	By Company Name	By Category

### Listed Companies' Announcements by Company Name :

A B C D E F G H I J K L M N O P Q R S T U V W X Y Z 0-9

Announcements before 1 November 2004		
View Results By		
By Date (Recent Announcements)	By Company Name	By Category

Printer-Friendly Version

Miscellaneous
* Asterisks denote mandatory information

Name of Announcer *	SINGAPORE AIRPORT TERMINAL SERVICES LIMITED
Company Registration No.	197201770G
Announcement submitted on behalf of	SPORE AIRPORT TERMINAL SVCSLTD
Announcement is submitted with respect to *	SINGAPORE AIRPORT TRML SVCSLTD
Announcement is submitted by *	ANNABELLE YIP
Designation *	COMPANY SECRETARY
Date & Time of Broadcast	03-Nov-2004 17:35:27
Announcement No.	00034

**>> Announcement Details**

The details of the announcement start here ...

**Announcement Title \***

Sides of Results Briefing to Analysts/Media on 2nd Quarter FY04-05 Financial Performance

**Description**

**Attachments:**

 SATS-2QFY2005-Results-Briefing.pdf  
 Total size = **481K**  
 (2048K size limit recommended)

[Previous Announcement](#)   [Next Announcement](#)

All Rights Reserved. Copyright ( ) 2003, Singapore Exchange Ltd. Company Reg. No. 199904940D  
 2 Shenton Way, #19-00 SGX Centre 1, Singapore 068804. Tel: (65) 6236 8888 Fax: (65) 6535 6994

**1st Half and 2nd Quarter  
FY2004-05**

---

Financial Results Review

Results Briefing for Analysts/Media

29 October 2004

- **Financial Review**
  - **Financial Highlights**
  - **Revenue Analysis**
  - **Expenditure Analysis**
- **Associated Companies**
- **Operating Data Review**
- **Outlook**

# Financial Highlights

# Financial Highlights (1st Half)

(S\$m)	1H 2004-05	1H 2003-04	% Change	1H 2002-03	% Change
Operating Revenue	484.0	388.0	24.7	465.6	4.0
Operating Expenditure	377.7	307.3	22.9	343.7	9.9
Operating Profit	106.3	80.7	31.7	121.9	(12.8)
Share of profits from associated companies	24.3	15.2	59.9	14.0	73.6
PBT before exceptional item	132.0	96.5	36.8	134.2	(1.6)
Exceptional item	28.8	8.0	260.0	-	-
PBT	103.2	88.5	16.6	134.2	(23.1)
PATMI	80.7	78.8	2.4	118.2	(31.7)

# Half Year Trend

(S\$m) —■— Revenue —▲— Expenditure —×— Operating Profit —■— PATMI

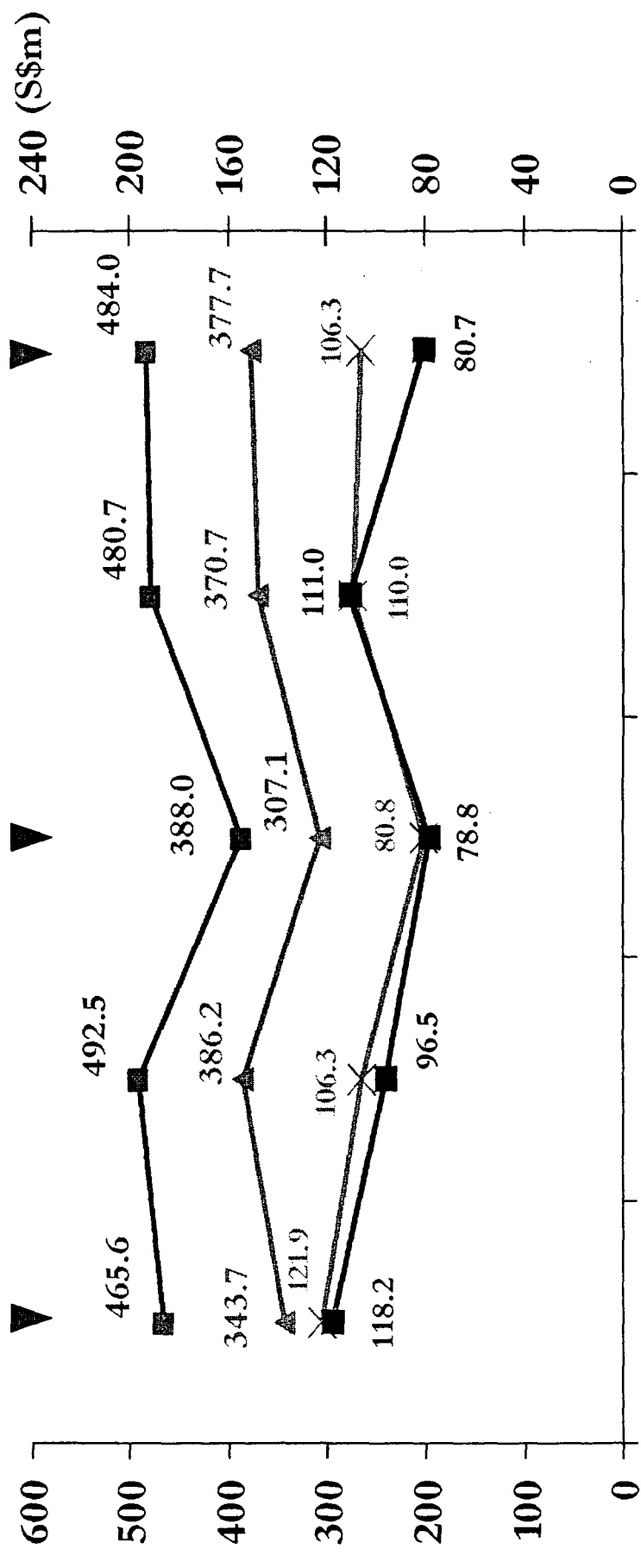

1H 2H 1H 2H 1H  
 FY2002-03 FY2003-04 FY2004-05





# Financial Highlights (2<sup>nd</sup> Qtr)

(S\$m)	2Q 2004-05	2Q 2003-04	% Change	2Q 2002-03	% Change
Operating Revenue	246.1	215.3	14.3	238.0	3.4
Operating Expenditure	190.1	157.6	20.6	175.5	8.3
Operating Profit	56.0	57.7	(2.9)	62.5	(10.4)
Share of profits from associated companies	13.3	8.6	54.7	6.7	98.5
PBT before exceptional item	69.5	66.4	4.7	68.4	1.6
Exceptional item	28.8	-	-	-	-
PBT	40.7	66.4	(38.7)	68.4	(40.5)
PATMI	31.4	50.9	(38.3)	49.3	(36.3)

# Quarterly Trends

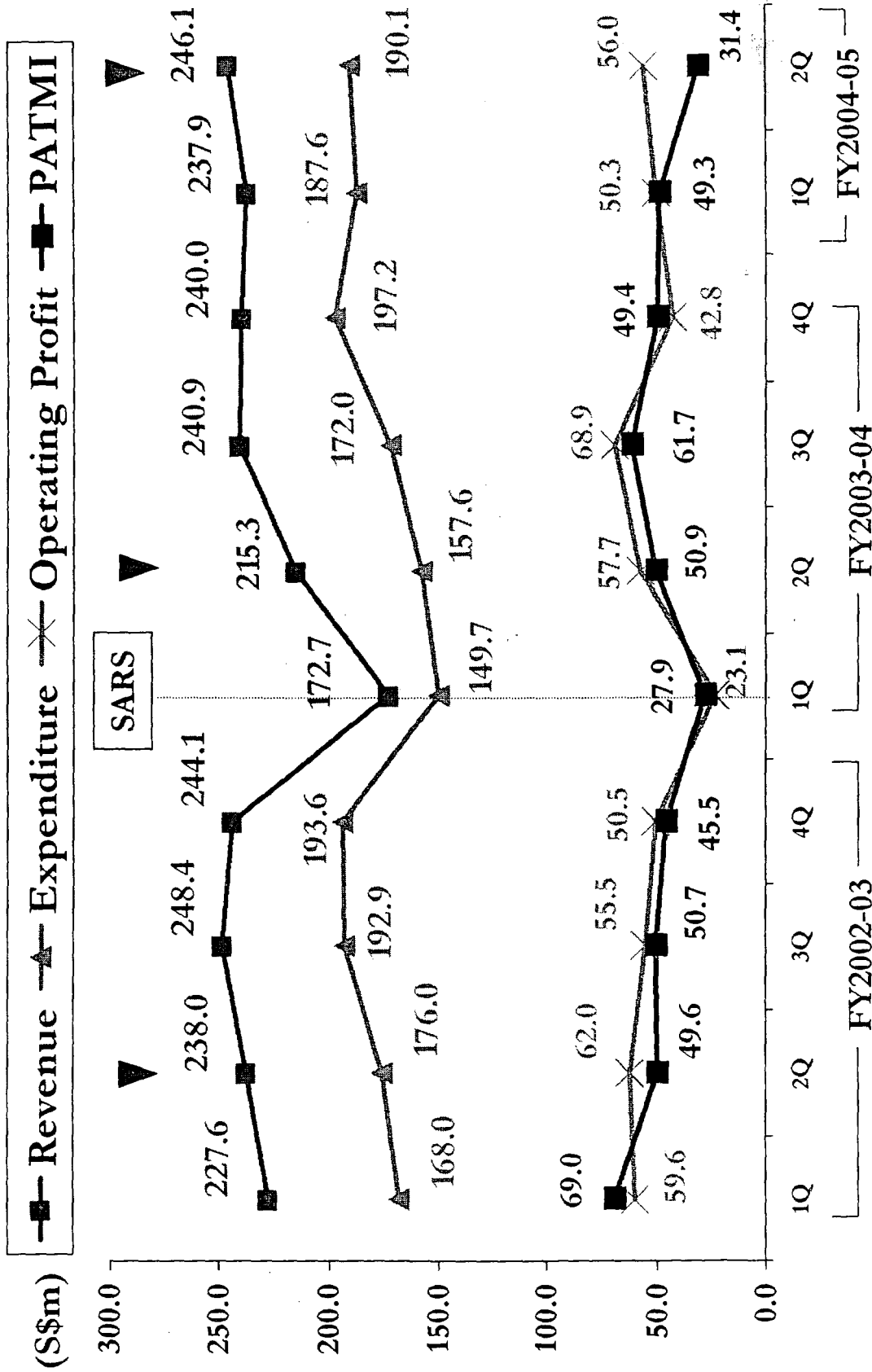

# Ratios and Margins

(S\$m)	1H 2004-05	1H 2003-04	% Change	2Q 2004-05	2Q 2003-04	% Change
Operating Profit Margin	22.0	20.8	1.2 pts	22.8	26.8	(4.0) pts
EBITDA* Margin	34.0	32.9	1.1 pts	35.5	38.5	(3.0) pts
PBT* Margin	27.3	24.9	2.4 pts	28.2	30.8	(2.6) pts
PBT Margin	21.3	22.8	(1.5) pts	16.5	30.8	(14.3) pts
Net Margin	16.7	20.3	(3.6) pts	12.8	23.6	(10.8) pts
Annualised return on Shareholders' Funds	14.6	15.2	(0.6) pt	11.2	18.0	(6.8) pts
Share of profits of associated companies over						
PBT*	18.4	15.8	2.6 pts	19.1	13.0	6.1 pts
PBT	23.5	17.2	6.3 pts	32.7	13.0	19.7 pts

\* Before exceptional item (\$28.8 million)

# Balance Sheet

(S\$m)	As at 30 Sep 2004	As at 31 Mar 2004	% Change
Issued and fully paid shares	102.4	100.6	1.8
Shareholders' funds	995.8	1,228.1	(18.9)
Total assets	1,562.0	1,558.6	0.2
Total debt	254.6	49.7	412.3
Total debt equity ratio (times)	0.26	0.04	
Net asset value per share (cents)	97.2	122.1	

# Revenue Analysis

# Segmental Revenue

(S\$m)	1H 2004-05	1H 2003-04	% Change	2Q 2004-05	2Q 2003-04	% Change
SATS Airport Services	214.7	195.1	10.0	108.2	104.3	3.7
SATS Catering	211.4	151.4	39.6	108.7	88.8	22.4
SATS Security Services	37.6	25.7	46.3	18.5	13.8	34.1
Others	20.3	15.8	28.5	10.7	8.4	27.3
<b>GROUP</b>	<b>484.0</b>	<b>388.0</b>	<b>24.7</b>	<b>246.1</b>	<b>215.3</b>	<b>14.3</b>

# Revenue Composition

SATS Security Svcs (6.4%)  
 Others (3.9%)

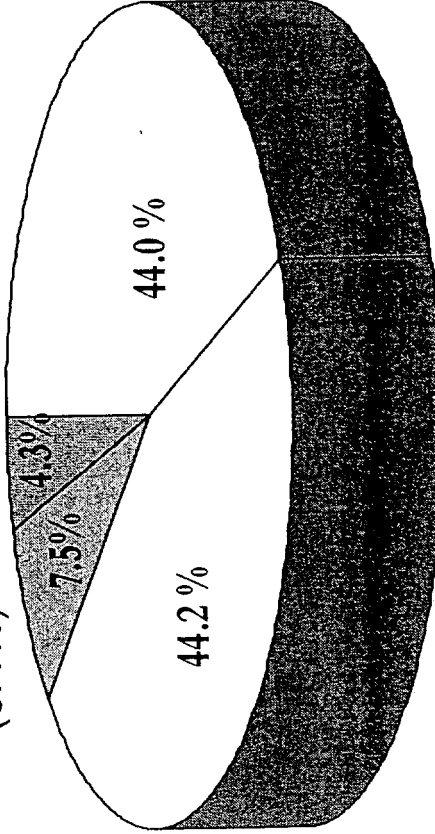

SATS Catering (41.2%)  
 SATS Airport Services (48.5%)

**2nd Qtr**

SATS Security Svcs (6.6%)  
 Others (4.0%)

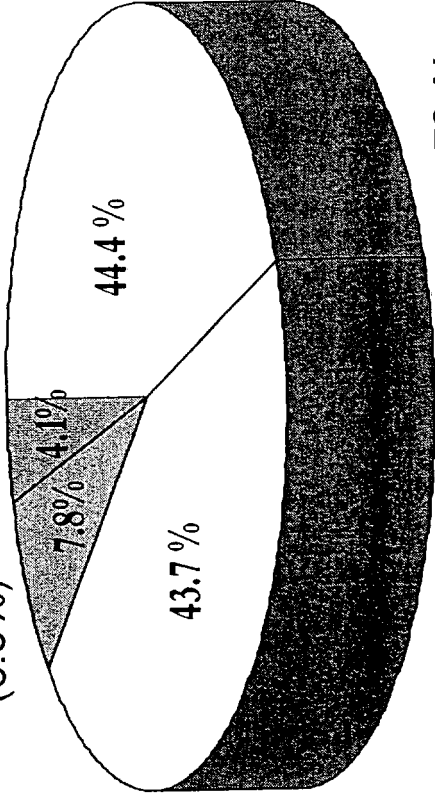

SATS Catering (39.0%)  
 SATS Airport Services (50.3%)

**1st Half**

Figures in ( ) refer to composition for same period last FY (03-04)



# Expenditure Analysis



# Group Expenditure

(S\$m)	1H 2004-05	1H 2003-04	% Change	2Q 2004-05	2Q 2003-04	% Change
Staff costs	205.8	155.5	32.3	102.5	75.5	35.8
Cost of raw materials	44.0	27.9	57.7	22.7	16.8	35.1
Licensing fees	32.8	27.1	21.0	16.4	15.1	8.6
Depreciation charges	31.2	30.4	2.6	15.6	15.4	1.3
Company Accommodation & Utilities	28.0	28.7	(2.4)	14.0	14.4	(2.8)
Other costs	35.9	37.7	(4.8)	18.9	20.4	(7.4)
<b>TOTAL</b>	<b>377.7</b>	<b>307.3</b>	<b>22.9</b>	<b>190.1</b>	<b>157.6</b>	<b>20.6</b>

# Group Expenditure

**2nd Qtr**

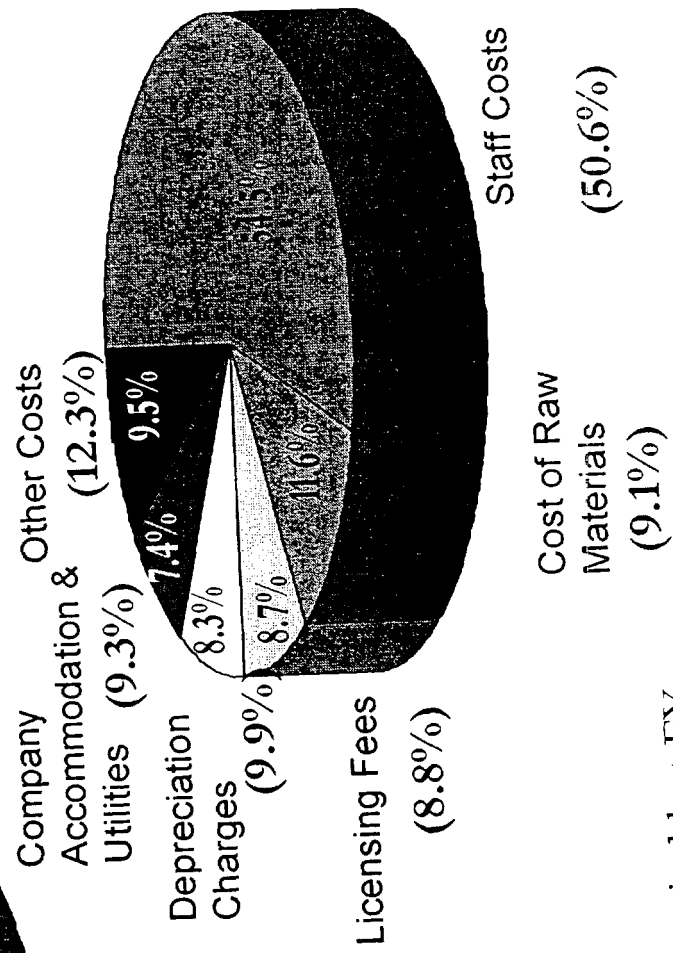
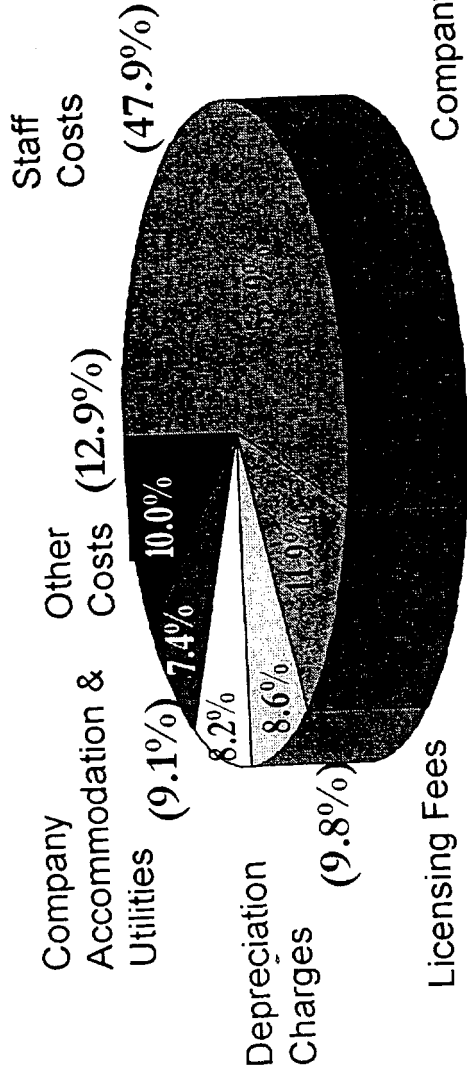

**1st Half**

Figures in ( ) refer to composition for same period last FY

# Associated Companies



# Associated Companies

## IN THE PAST SIX MONTHS, NEW OVERSEAS ACQUISITIONS:

- August 2004 : acquisition of an additional 24.5% stake in  
Asia Airfreight Terminal (AAT) for S\$76.5m.  
- current stake now 49.0%
- June 2004 : acquisition of 49.8% stake in  
JAS Airport Services (JAS) in Indonesia for  
US\$60m (S\$103m).  
- present in 10 airports in Indonesia

# Associated Companies

22 airports  
in  
7 countries

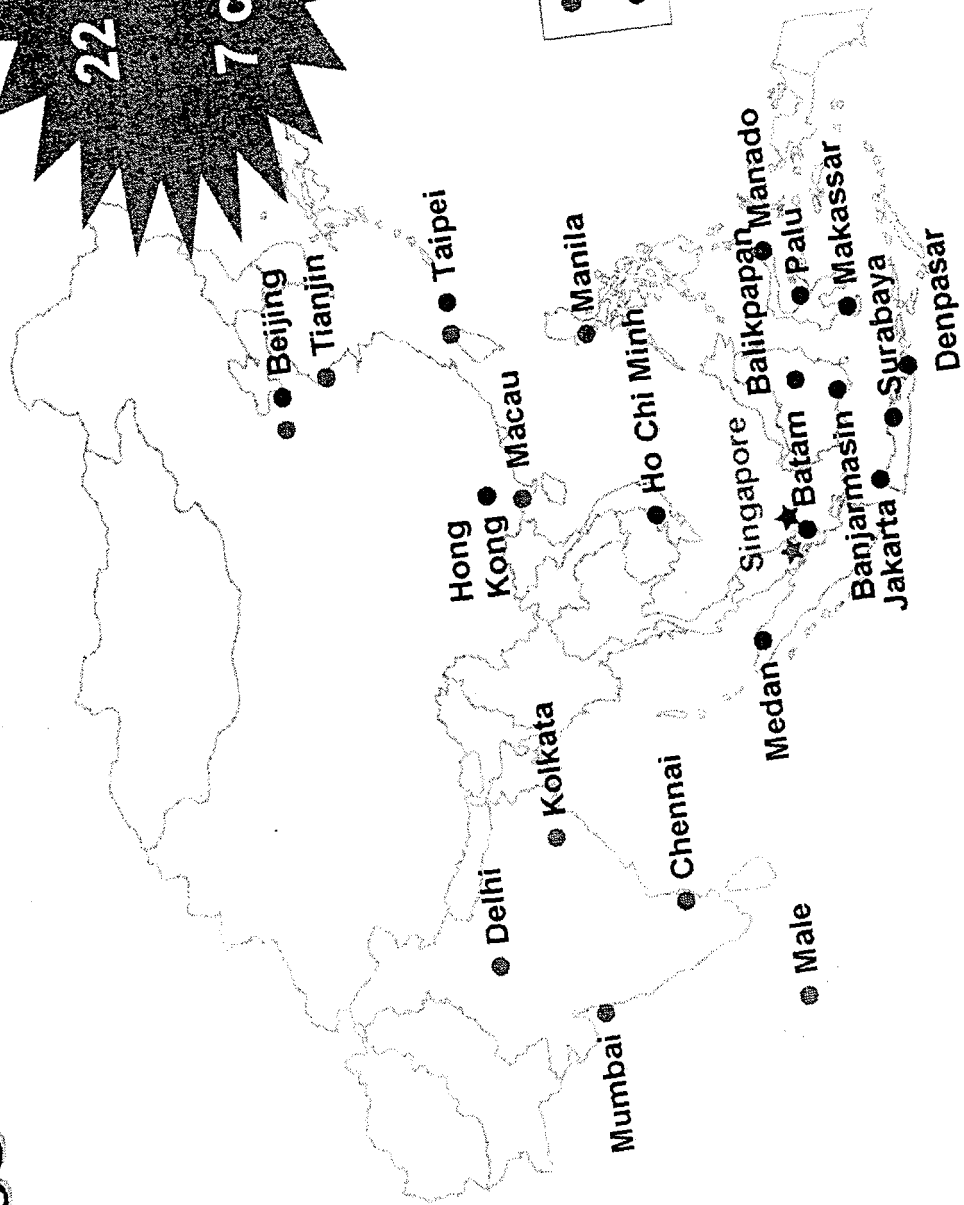

- Inflight Catering
- Ground Handling



# Associated Companies

(S\$m)	1H 2004-05	1H 2003-04	% Change	2Q 2004-05	2Q 2003-04	% Change
Inflight Catering	5.3	3.3	58.5	2.8	2.0	40.0
Ground Handling	19.1	11.9	60.0	10.5	6.6	59.1
Share of Associated Companies' PBT	24.3	15.2	59.9	13.3	8.6	54.7
% of SATS Group PBT*	18.4	15.8	2.6 pts	19.1	13.0	6.1 pts
% of SATS Group PBT	23.5	17.2	6.3 pts	32.7	13.0	19.7 pts

\* Before exceptional item (\$28.8 million)

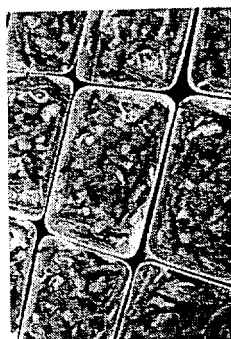
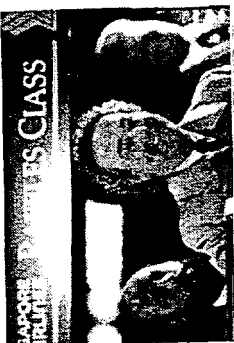

# Operating Data Review

# Operating Data

	1H 2004-05	1H 2003-04	% Change	2Q 2004-05	2Q 2003-04	% Change
Flights Handled ('000)	36.9	28.3	30.3	18.7	15.2	23.4
Cargo/Mail Processed ('000 tonnes)	713.9	676.6	5.5	363.2	346.9	4.7
Meals Produced ('M)	11.5	8.5	34.8	6.0	5.2	14.7
Passengers Handled ('M)	12.4	8.9	38.9	6.3	5.7	11.9



# Flights Handled ('000)

■ FY2003-04   ▲ FY2004-05   \* FY2002-03

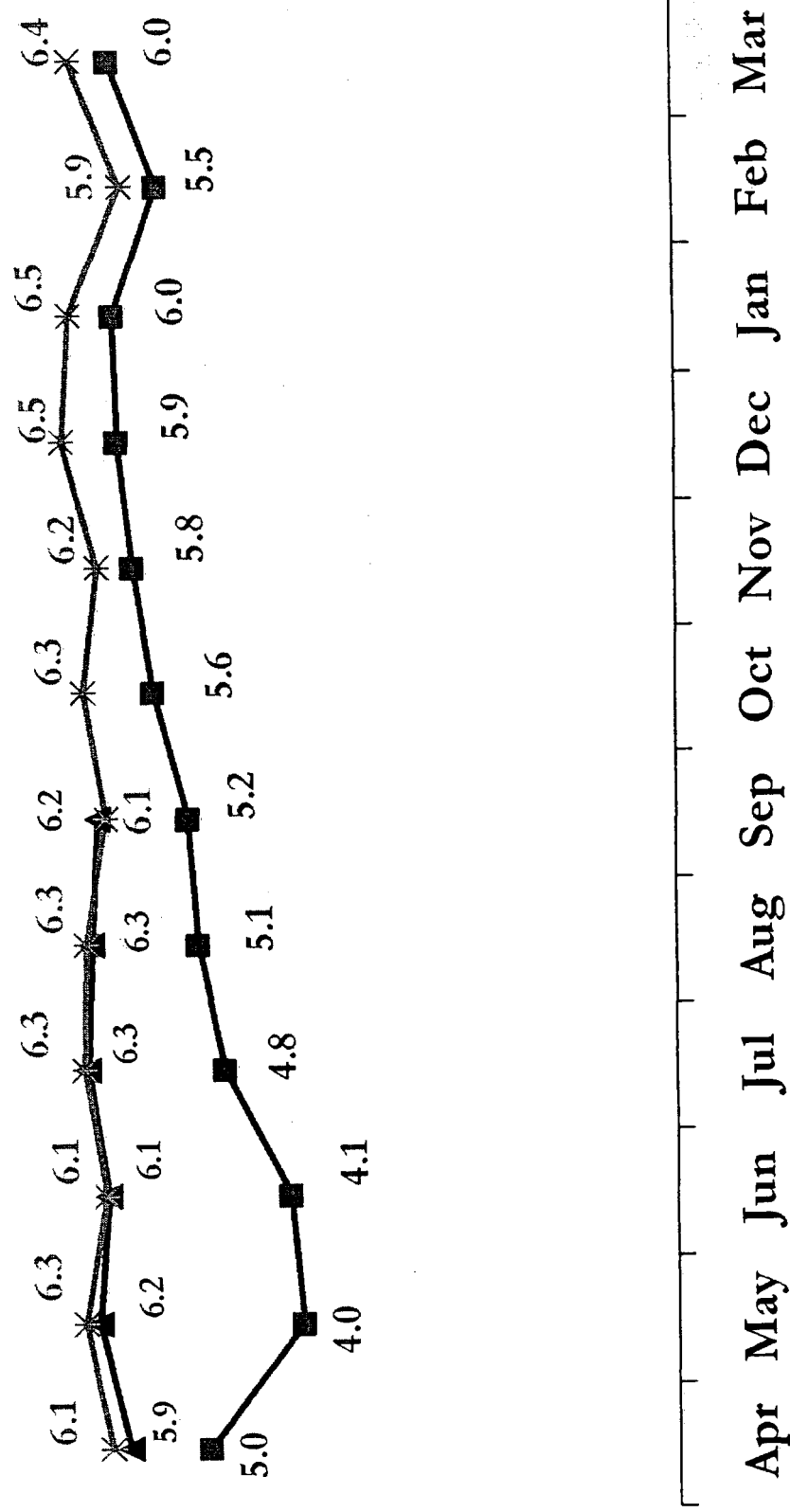

# Meals Processed ('M)

-■- FY2003-04    -▲- FY2004-05    -\*-\* FY2002-03

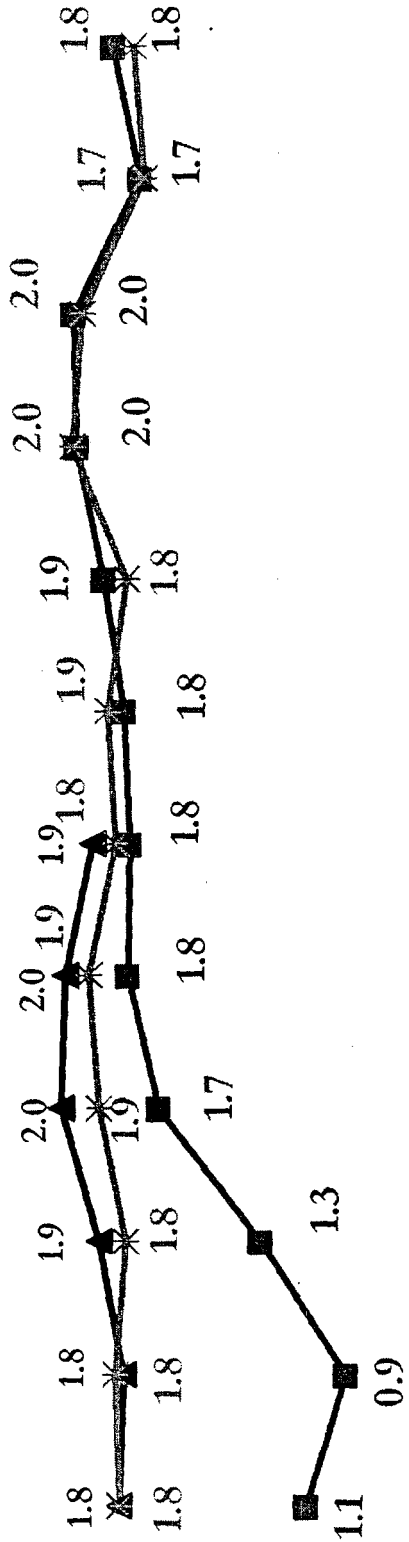

Apr May Jun Jul Aug Sep Oct Nov Dec Jan Feb Mar



# Cargo/Mail Processed ('000 tonnes)

■ FY2003-04    ▲ FY2004-05    \* FY2002-03

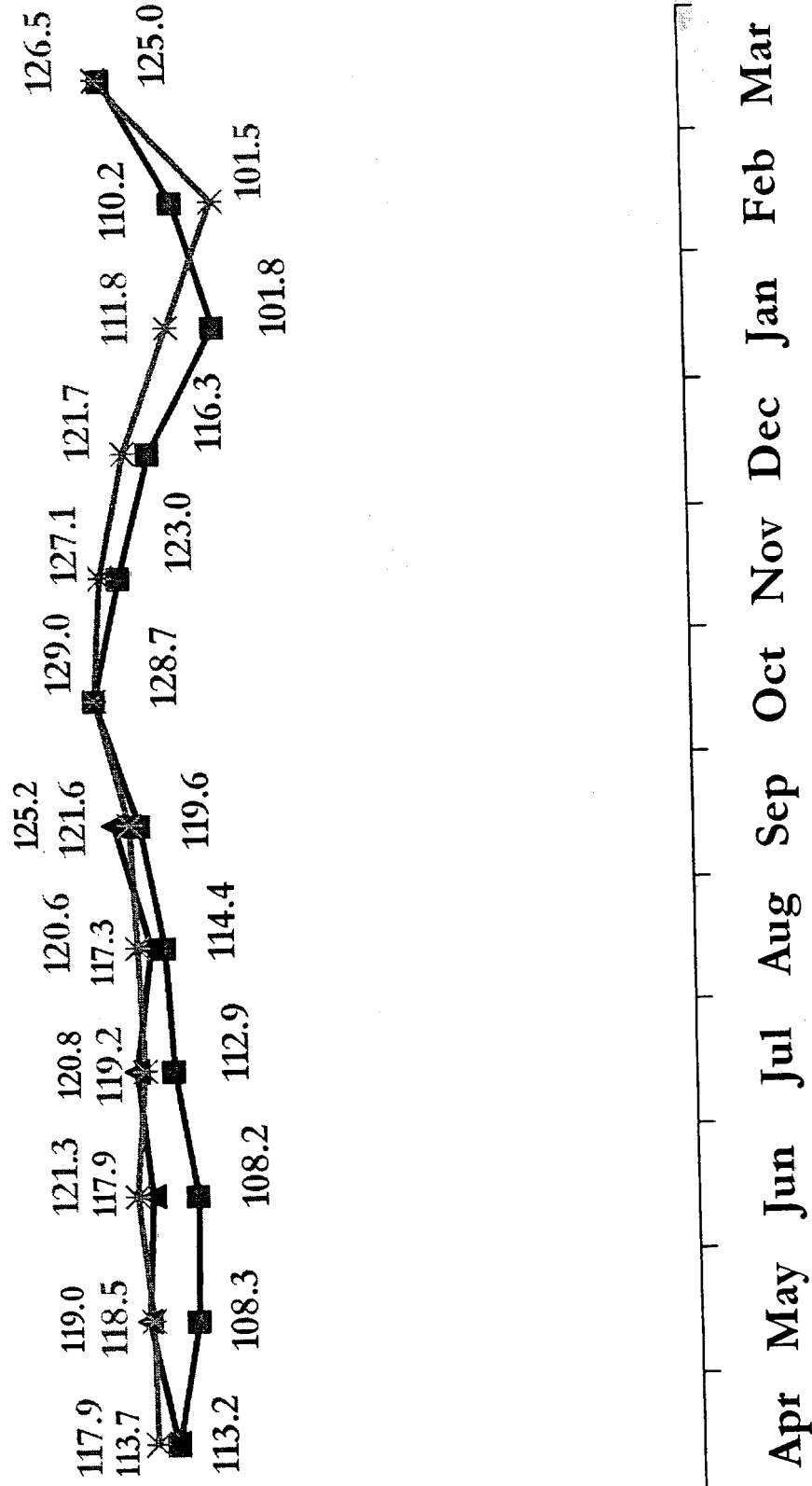

# Outlook

# Outlook

Flight frequencies and passenger loads for the second half of the financial year are expected to improve further. However, operating margins are expected to come under pressure due to increased competition.

In line with traffic growth, profit contribution from our associated companies is expected to improve.

The major workforce restructuring exercise in September 2004 has put the Group in a better position to meet the competition ahead.

**End / Q&A**



# Corporate Structure

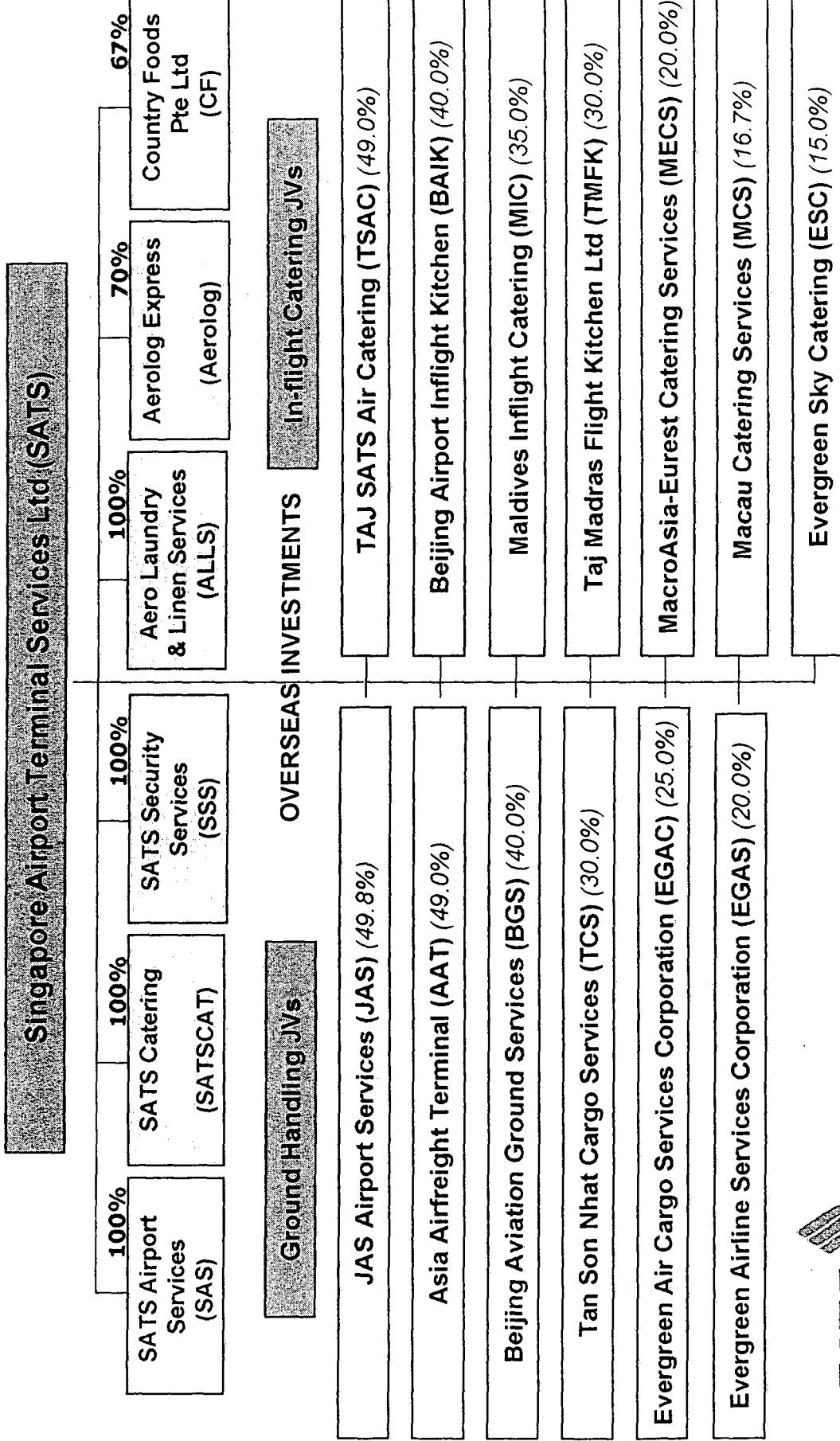



**SGX. Tomorrow's Market. Today**

Prices | Products/Services | Listed Companies | Our Shareholders | Regulation | About SGX

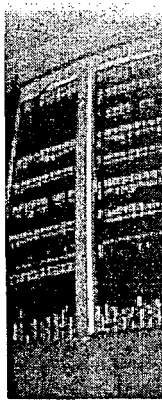

I want to go to .....

Home » [Listed Companies](#) » [Announcements](#)

## Announcements

[New Listings](#)  
[Annual Report/Fin. Report](#)  
[Company's All-In-One Info](#)

[Research Reports](#)  
[AGM Schedules](#)  
[Prospectus/Circulars](#)

[Announcements](#)  
[Stock/Indices List](#)

[ISIN Code Download](#)  
[Corporate Info](#)

[Corporate Action](#)  
[Warrants](#)

[Tax Incentive Schemes](#)  
[Market Cap](#)

[Sharebuyback Form](#)

View Results By	
<a href="#">By Date (Recent Announcements)</a>	<a href="#">By Company Name</a>
<a href="#">By Category</a>	

Listed Companies' Announcements by Company Name :

[A](#) [B](#) [C](#) [D](#) [E](#) [F](#) [G](#) [H](#) [I](#) [J](#) [K](#) [L](#) [M](#) [N](#) [O](#) [P](#) [Q](#) [R](#) [S](#) [T](#) [U](#) [V](#) [W](#) [X](#) [Y](#) [Z](#) [0-9](#)

Listed Companies' Announcement

[Printer Friendly Version](#)



**SATS** SINGAPORE AIRPORT TERMINAL SERVICES LIMITED

**Financial Statements for the Second Quarter and Half Year ended 30 September 2004**





SATS-2QFY04-05-Results.pdf  
Submitted by Annabelle Yip Wai Ping, Company Secretary on 28 October 2004 to the SGX

Next Annnc Prev Annnc

All Rights Reserved. Copyright ( ) 2003, Singapore Exchange Ltd. Company Reg. No. 199904940D  
2 Shenton Way, #19-00 SGX Centre 1, Singapore 069804. Tel: (65) 6236 8888 Fax: (65) 6535 6994



**UNAUDITED RESULTS FOR THE SECOND QUARTER AND HALF YEAR  
ENDED 30 SEPTEMBER 2004**

1(a) An income statement (for the group), together with a comparative statement for the corresponding period of the immediately preceding financial year.

PROFIT AND LOSS ACCOUNTS (in \$ million)  
for the second quarter and half year ended 30 September 2004

	THE GROUP			
	2 <sup>nd</sup> Quarter		Half Year	
	2004-05	2003-04	2004-05	2003-04
<b>REVENUE</b>	246.1	215.3	484.0	388.0
<b>EXPENDITURE</b>				
Staff costs	(102.5)	(75.5)	(205.8)	(155.5)
Cost of raw materials	(22.7)	(16.8)	(44.0)	(27.9)
Licensing fees	(16.4)	(15.1)	(32.8)	(27.1)
Depreciation charges	(15.6)	(15.4)	(31.2)	(30.4)
Company accommodation and utilities	(14.0)	(14.4)	(28.0)	(28.7)
Other costs	(18.9)	(20.4)	(35.9)	(37.7)
	<u>(190.1)</u>	<u>(157.6)</u>	<u>(377.7)</u>	<u>(307.3)</u>
<b>OPERATING PROFIT</b>	56.0	57.7	106.3	80.7
Interest on borrowings	(0.7)	(1.5)	(0.8)	(3.0)
Interest income	0.6	1.2	1.5	2.6
Amortisation of deferred income	0.3	0.4	0.7	0.9
Gain on disposal of fixed assets	-	-	-	0.1
Share of profits of associated companies	13.3	8.6	24.3	15.2
<b>PROFIT BEFORE EXCEPTIONAL ITEM</b>	<u>69.5</u>	<u>66.4</u>	<u>132.0</u>	<u>96.5</u>
Exceptional items*	(28.8)	-	(28.8)	(8.0)
<b>PROFIT BEFORE TAXATION</b>	<u>40.7</u>	<u>66.4</u>	<u>103.2</u>	<u>88.5</u>
Taxation	(9.2)	(15.6)	(22.4)	(9.8)
<b>PROFIT AFTER TAXATION</b>	<u>31.5</u>	<u>50.8</u>	<u>80.8</u>	<u>78.7</u>
Minority Interests	(0.1)	0.1	(0.1)	0.1
<b>PROFIT ATTRIBUTABLE TO SHAREHOLDERS</b>	<u>31.4</u>	<u>50.9</u>	<u>80.7</u>	<u>78.8</u>

**Notes :**

(i) Profit after taxation is arrived at after crediting/(charging):

Foreign exchange (loss)/gain, net	(0.1)	(1.1)	1.1	(1.6)
Adjustments for over provision of tax in respect of prior years	-	-	-	11.7

\* Cost of restructuring exercise

1(b)(i) A balance sheet (for the issuer and group), together with a comparative statement as at the end of the immediately preceding financial year.

BALANCE SHEETS At 30 September 2004 (in \$ million)

	THE GROUP		THE COMPANY	
	30.09.2004	31.03.2004	30.09.2004	31.03.2004
<b>Share capital</b>				
Authorised:	200.0	200.0	200.0	200.0
<b>Issued and fully-paid</b>	102.4	100.6	102.4	100.6
<b>Share premium</b>	38.7	8.7	38.7	8.7
<b>Distributable reserves</b>				
Revenue reserve	851.1	1,113.1	447.6	689.7
Foreign currency translation reserve	1.0	3.2	-	-
<b>Non-distributable reserve</b>				
Statutory reserve	2.6	2.5	-	-
<b>Shareholders' funds</b>	995.8	1,228.1	588.7	799.0
<b>Minority interests</b>	2.6	2.5	-	-
<b>Deferred taxation</b>	79.4	81.3	40.9	41.3
<b>Loan from immediate holding company</b>	45.9	43.6	45.9	43.7
<b>Notes Payable</b>	200.0	-	200.0	-
<b>Term loan</b>	4.6	3.0	-	-
<b>Deferred income</b>	28.8	29.8	28.7	29.8
	<u>1,357.1</u>	<u>1,388.3</u>	<u>904.2</u>	<u>913.8</u>
Represented by:-				
<b>Fixed assets</b>				
Leasehold land and buildings	560.7	578.2	545.1	561.6
Progress payments	21.7	25.2	0.2	0.2
Others	180.5	185.7	2.3	2.8
	762.9	789.1	547.6	564.6
<b>Subsidiaries</b>	-	-	43.3	43.3
<b>Associated companies</b>	323.8	141.0	270.3	95.2
<b>Long-term investments</b>	7.9	7.9	7.9	7.9
<b>Goodwill on consolidation</b>	1.4	1.4	-	-
<b>Loan to third party</b>	45.9	43.6	45.9	43.7
<b>Current assets</b>				
Trade debtors	64.3	60.0	4.1	1.1
Other debtors	12.5	9.3	4.2	5.4
Related companies	130.3	215.0	75.1	145.1
Associated companies	0.8	0.6	0.8	0.6
Stocks	10.6	9.0	0.3	0.3
Short-term non-equity investments	40.2	94.8	40.2	94.8
Bank fixed deposits	148.0	177.1	148.0	176.1
Cash and bank balance	13.4	9.8	6.4	3.9
	420.1	575.6	279.1	427.3
<b>Less: Current liabilities</b>				
Term loan	1.2	0.8	-	-
Bank overdraft - secured	2.9	2.3	-	-
Trade creditors	136.8	85.6	17.2	3.6
Other creditors	10.5	25.7	4.9	19.7
Related companies	-	-	255.4	232.6
Provision for taxation	53.5	55.9	12.4	12.3
	204.9	170.3	289.9	268.2
<b>Net current assets</b>	<u>215.2</u>	<u>405.3</u>	<u>(10.8)</u>	<u>159.1</u>
	<u>1,357.1</u>	<u>1,388.3</u>	<u>904.2</u>	<u>913.8</u>

**1(b) (ii) Aggregate amount of group's borrowings and debt securities**

(In \$ million)

Amount repayable in one year or less, or on demand

<u>As at 30.09.2004</u>		<u>As at 31.03.2004</u>	
<u>Secured *</u>	<u>Unsecured</u>	<u>Secured *</u>	<u>Unsecured</u>
3.0	1.1	2.5	0.6

Amount repayable after one year

<u>As at 30.09.2004</u>		<u>As at 31.03.2004</u>	
<u>Secured *</u>	<u>Unsecured</u>	<u>Secured *</u>	<u>Unsecured</u>
2.7	247.8	2.7	43.9

**Details of any collateral**

\* Secured by a first legal mortgage on the building located at 22 Senoko Way occupied by subsidiary, M/s Country Foods Pte Ltd.

1(c) A cash flow statement (for the group), together with a comparative statement for the corresponding period of the immediately preceding financial year.

**CONSOLIDATED CASH FLOW STATEMENTS (in \$ million)  
for the second quarter and half year ended 30 September 2004**

	<b>THE GROUP</b>			
	<b>2nd Quarter</b>		<b>Half Year</b>	
	<b>2004-05</b>	<b>2003-04</b>	<b>2004-05</b>	<b>2003-04</b>
<b><u>Cash flows from operating activities</u></b>				
Profit before taxation	40.7	66.4	103.2	88.5
Adjustments for:				
Interest income	(0.6)	(1.2)	(1.5)	(2.6)
Interest on borrowings	0.7	1.5	0.8	3.0
Depreciation of fixed assets	15.6	15.4	31.2	30.4
Effects of exchange rate changes	0.5	1.1	(0.3)	1.2
Gain on disposal of fixed assets	-	-	-	(0.1)
Share of profits of associated companies	(13.3)	(8.6)	(24.3)	(15.2)
Amortisation of deferred income	(0.3)	(0.4)	(0.7)	(0.9)
Operating profit before working capital changes	43.3	74.2	108.4	104.3
Decrease/(increase) in debtors	2.0	(6.8)	(7.9)	12.1
(Increase)/decrease in stocks	(0.4)	0.4	(1.7)	1.7
Decrease/(increase) in amounts owing by related companies	10.3	(21.8)	4.7	0.7
Increase/(decrease) in creditors	18.3	(29.9)	37.9	(35.7)
Decrease/(increase) in amounts due from associated companies	0.3	(0.2)	0.3	-
Cash generated from operations	73.8	15.9	141.7	83.1
Interest paid to third parties	(0.2)	(3.0)	(0.2)	(3.0)
Tax paid	(13.5)	(12.0)	(20.7)	(13.4)
Net cash provided by operating activities	60.1	0.9	120.8	66.7
<b><u>Cash flows from investing activities</u></b>				
Purchase of fixed assets	(3.2)	(6.9)	(7.9)	(18.3)
Investments in associated companies	(73.2)	-	(175.1)	-
Repayment of loan from associated company	0.1	0.2	0.1	0.2
Dividends from associated companies	1.6	6.4	8.3	8.3
Proceeds from disposal of fixed assets	-	-	0.2	0.3
Interest received from deposits	1.1	1.7	1.8	2.4
Decrease/(increase) in short-term non-equity investments	1.5	7.8	54.6	(11.3)
Net cash provided by / (used in) investing activities	(72.1)	9.2	(118.0)	(18.4)
<b><u>Cash flows from financing activities</u></b>				
Proceeds of notes issued during the year	200.0	-	200.0	-
(Repayment of) proceeds from term loan	(0.3)	(0.2)	2.0	2.6
Proceeds from exercise of share options	25.6	5.9	31.8	5.9
Dividends paid	(342.6)	(31.2)	(342.6)	(31.2)
Net cash used in financing activities	(117.3)	(25.5)	(108.8)	(22.7)
Net (decrease)/increase in cash and cash equivalents	(129.3)	(15.4)	(106.0)	25.6
Effects of exchange rate changes	(0.5)	(1.1)	0.3	(1.2)
Cash and cash equivalents at beginning of the period	327.7	391.1	303.6	350.2
Cash and cash equivalents at end of the period	197.9	374.6	197.9	374.6

1(d) A statement (for the issuer and group) showing either (i) all changes in equity or (ii) changes in equity other than those arising from capitalisation issues and distributions to shareholders, together with a comparative statement for the corresponding period of the immediately preceding financial year.

STATEMENT OF CHANGES IN EQUITY (in \$ million)  
for the second quarter ended 30 September 2004

	Share Capital	Share Premium	Revenue Reserve	Statutory Reserve*	Foreign Currency Translation Reserve	Total Share- holders' Equity
<b>THE GROUP</b>						
Balance at 30 June 2004	100.9	14.6	1,162.4	2.5	4.2	1,284.6
Share options exercised	1.5	24.1	-	-	-	25.6
Transfer to statutory reserve	-	-	(0.1)	0.1	-	-
Foreign currency translation adjustment	-	-	-	-	(3.2)	(3.2)
Net gain/(loss) not recognised in the profit and loss accounts	-	-	(0.1)	0.1	(3.2)	(3.2)
Profit attributable to shareholders for the period	-	-	31.4	-	-	31.4
Dividends, net	-	-	(342.6)	-	-	(342.6)
<b>Balance at 30 September 2004</b>	<b>102.4</b>	<b>38.7</b>	<b>851.1</b>	<b>2.6</b>	<b>1.0</b>	<b>995.8</b>
Balance at 30 June 2003	100.0	-	1,006.7	1.6	6.5	1,114.8
Share options exercised	0.4	5.5	-	-	-	5.9
Transfer from statutory reserve	-	-	(0.1)	0.1	-	-
Foreign currency translation adjustment	-	-	-	-	(0.8)	(0.8)
Net gain/(loss) not recognised in the profit and loss accounts	-	-	(0.1)	0.1	(0.8)	(0.8)
Profit attributable to shareholders for the period	-	-	50.9	-	-	50.9
Dividends, net	-	-	(31.2)	-	-	(31.2)
<b>Balance at 30 September 2003</b>	<b>100.4</b>	<b>5.5</b>	<b>1,026.3</b>	<b>1.7</b>	<b>5.7</b>	<b>1,139.6</b>

\* Certain countries in which some of the Group's associated companies are incorporated legally require statutory reserves to be set aside. The laws of the countries restrict the distribution and use of these statutory reserves.

**STATEMENT OF CHANGES IN EQUITY (in \$ million) (Cont'd)**  
**for the second quarter ended 30 September 2004**

	Share Capital	Share Premium	Revenue Reserve	Total Share- holders' Equity
<b><u>THE COMPANY</u></b>				
Balance at 30 June 2004	100.9	14.6	701.7	817.2
Share options exercised	1.5	24.1	-	25.6
Profit attributable to shareholders for the period	-	-	88.5	88.5
Dividends, net	-	-	(342.6)	(342.6)
<b>Balance at 30 September 2004</b>	<b>102.4</b>	<b>38.7</b>	<b>447.6</b>	<b>588.7</b>
Balance at 30 June 2003	100.0	-	630.1	730.1
Share options exercised	0.4	5.5	-	5.9
Profit attributable to shareholders for the period	-	-	8.1	8.1
Dividends, net	-	-	(31.2)	(31.2)
<b>Balance at 30 September 2003</b>	<b>100.4</b>	<b>5.5</b>	<b>607.0</b>	<b>712.9</b>

1(d)(ii) Details of any changes in the company's share capital arising from rights issue, bonus issue, share buy-backs, exercise of share options or warrants, conversion of other issues of equity securities, issue of shares for cash or as consideration for acquisition or for any other purpose since the end of the previous period reported on. State also the number of shares that may be issued on conversion of all the outstanding convertibles as at the end of the current financial period reported on and as at the end of the corresponding period of the immediately preceding financial year.

#### SHARE CAPITAL AND OPTIONS ON SHARES IN THE COMPANY

(i) The issued and paid-up capital of the Company increased from S\$100,948,313 as at 30 June 2004 to S\$102,413,138 as at 30 September 2004. The increase was due to new ordinary shares of S\$0.10 each of the Company ("Shares") allotted and issued pursuant to the exercise of options granted under the SATS Employee Share Option Plan ("Plan"), which comprises the Senior Executive Share Option Scheme for senior executives and the Employee Share Option Scheme for all other employees.

(ii) On 1 July 2004, options were granted under the Plan to eligible employees to subscribe for 17,658,100 Shares, out of which options in respect of 16,329,600 Shares were accepted by the employees. The exercise periods of the said options commence on 1 July 2005 for Senior Executives (as defined under the Plan) and 1 July 2006 for other employees, and expire on 30 June 2014. The exercise price of the Shares under the said options is S\$2.09\* per Share.

(iii) As at 30 September 2004, options to subscribe for a total of 66,802,300 Shares were outstanding under the Plan. As at 30 September 2003, options to subscribe for a total of 71,678,000 Shares were outstanding under the Plan.

(iv) The movement of options to subscribe for Shares granted under the Plan during the period 1 July 2004 to 30 September 2004 was as follows:

<u>Date of grant</u>	<u>Balance at 01.07.2004</u>	<u>Lapsed</u>	<u>Exercised</u>	<u>Not Accepted</u>	<u>Balance at 30.09.2004</u>	<u>Exercise price*</u>	<u>Expiry date</u>
28.3.2000	17,450,800	50,800	-	-	17,400,000	S\$2.20	27.3.2010
3.7.2000	12,004,850	13,200	2,942,050	-	9,049,600	S\$1.80	2.7.2010
2.7.2001	7,088,350	8,500	4,073,550	-	3,006,300	S\$1.24	1.7.2011
1.7.2002	14,709,850	19,100	7,364,950	-	7,325,800	S\$1.60	30.6.2012
1.7.2003	14,044,200	51,100	267,700	-	13,725,400	S\$1.47	30.6.2013
1.7.2004	17,658,100	34,400	-	1,328,500	16,295,200	S\$2.09	30.6.2014
	<u>82,956,150</u>	<u>177,100</u>	<u>14,648,250</u>	<u>1,328,500</u>	<u>66,802,300</u>		

\* At the extraordinary general meeting of the Company held on 20 July 2004, the Company's shareholders approved an amendment to the Plan allowing for adjustment to the exercise prices of existing options by the Committee administering the Plan, in the event of the declaration of a special dividend. At the same meeting, the Company's shareholders approved the declaration of a special dividend. The said Committee then approved a S\$0.30 reduction of the exercise prices of the outstanding share options. Ernst & Young, the auditors of the Company, have confirmed such adjustments to be, in its opinion, fair and reasonable. The exercise prices reflected here are the exercise prices after such adjustment.

**2 Whether the figures have been audited, or reviewed and in accordance with which standard.**

The figures have not been audited.



3 Where the figures have been audited or reviewed, the auditor's report (including any qualifications or emphasis of matter).

Not applicable.

4 Whether the same accounting policies and methods of computation as in the issuer's most recently audited annual financial statements have been applied.

The same accounting policies and methods of computation have been applied.

5 If there are any changes in the accounting policies and methods of computation, including any required by an accounting standard, what has changed, as well as the reasons for, and the effect of, the change.

Not applicable.

6 Earnings per ordinary share of the group for the current financial period reported on and the corresponding period of the immediately preceding financial year, after deducting any provision for preference dividends.

	THE GROUP			
	2 <sup>nd</sup> Quarter		Half Year	
	2004-05	2003-04	2004-05	2003-04
EPS based on net profit attributable to shareholders (cents):				
(i) Basic *	3.1	5.1	8.0	7.9
(ii) Diluted #	3.1	5.1	7.9	7.9

\* Based on weighted average number of fully paid shares in issue.

# Based on weighted average number of fully paid shares in issue after adjusting for dilution of shares under the employee share option plan.

7 Net asset value (for the issuer and group) per ordinary share based on issued share capital of the issuer at the end of the (a) current financial period reported on and (b) immediately preceding financial year.

	THE GROUP		THE COMPANY	
	30.09.2004	31.03.2004	30.09.2004	31.03.2004
Net asset value per ordinary share (cents)	97.2	122.1	57.5	79.4

8 A review of the performance of the group, to the extent necessary for a reasonable understanding of the group's business. It must include a discussion of the following:- (a) any significant factors that affected the turnover, costs, and earnings of the group for the current financial period reported on, including (where applicable) seasonal or cyclical factors; and (b) any material factors that affected the cash flow, working capital, assets or liabilities of the group during the current financial period reported on.

## GROUP EARNINGS

### 8(a)(i) Financial highlights for half year ended 30 September 2004

#### Operating Profit and Net Profit

The Group's operating profit for the half year ended 30 September 2004 was \$106.3 million, \$25.6 million (+31.7%) higher than the same period in the previous year. However, the Group's profit after tax and minority interests was \$80.7 million, a marginal increase of \$1.9 million (+2.4%) from \$78.8 million in the same period last year because of the exceptional item of \$28.8 million and \$8.0 million being charged to the accounts in FY04/05 and FY03/04 respectively.

#### Balance Sheet

Shareholders' equity for the Group decreased from \$1,228.1 million as at 31 March 2004 to \$995.8 million as at 30 September 2004 mainly due to the payment of special dividend and final dividend of \$301.8 million \$40.8 million respectively on 4 August 2004. Profits for the half year was \$80.7 million, and share options exercised since 31 March 2004 amounted to \$31.8 million. The Company issued a \$200 million fixed rate notes with a maturity date of 2 September 2009.

#### Cash Flow

The Group has a cash balance of \$197.9 million as at 30 September 2004, a decrease of \$176.7 million compared to a year ago.

### 8(a)(ii) Detailed financial analysis for half year ended 30 September 2004

#### Operating Revenue

The segmental revenue and its composition are summarised below:

	Half Year 2004-05		Half Year 2003-04		% Change
	\$Million	%	\$Million	%	
Inflight catering	211.4	43.7	151.4	39.0	+ 39.6
Ground handling	214.7	44.3	195.1	50.3	+ 10.0
Security Services	37.6	7.8	25.7	6.6	+ 46.3
Others #	20.3	4.2	15.8	4.1	+ 28.5
Total	484.0	100.0	388.0	100.0	+ 24.7

# Other services include airline laundry services, cargo delivery, manufacturing and distribution of chilled and frozen processed food, and leasing of office space to airline clients and cargo agents.

The Group's operating revenue for the review period was \$488.0 million, an increase of \$96 million or 24.7% compared to \$388.0 million in the same period last year as airlines restored their flights to pre-SARS level.

Revenue from inflight catering went up 39.6% from \$151.4 million to \$211.4 million because of a 34.8% increase in the volume of inflight meals uplifted.

Revenue from ground handling increased 10.0% from \$195.1 million to \$214.7 million because of more flights handled and higher cargo volume handled in the current financial period.

Revenue from aviation security services rose 46.3% from \$25.7 million to \$37.6 million because of new security screening services rendered at the airport's gate hold room from September 2003.

Revenue from other services increased 28.5% from \$15.8 million to \$20.3 million.

#### Operating Expenditure

Total operating expenditure for the Group increased \$70.4 million (+22.9%) to \$377.7 million for the half year in FY2004-05 compared to \$307.3 million in the same period last year.

Staff costs rose \$50.3 million (+32.3%) to \$205.8 million in the first half of the year. This was mainly due to the provision for profit sharing bonus against a nil provision in the same period last year, and higher overtime and allowances because of the rise in business volume.

The higher operating costs came also from a \$16.1 million (+57.7%) increase in cost of raw materials as a result of higher number of meals produced and higher prices of seafood, meat and poultry.

#### Profit Contribution from Associated Companies

Profit contribution from overseas through associated companies increased \$9.1 million or 59.9% from \$15.2 million to \$24.3 million in the first half of the year. This represents 18.4% of the Group's profit before tax and exceptional item, a 2.6 percentage points rise from the same period last year.

#### Exceptional item

The exceptional item of \$28.8 million was the one-time payout to staff affected under the restructuring exercise that took place in the second quarter of the current financial year. The annual saving as a result of this exercise is approximately \$21.2 million.

#### Taxation

The Group's provision for taxation in first half of the year was \$22.4 million, \$12.6 million or 128.6% higher than the same period last year. The increase was because of a tax write-back of \$11.7 million in the first quarter last year.

#### 8(b)(i) Financial highlights for second quarter ended 30 September 2004

##### Operating Profit and Net Profit

The Group's operating profit for the current period was \$56.0 million, compared to \$57.7 million in the second quarter last year. However, the Group's profit after tax and minority interests was \$31.4 million, compared to \$50.9 million for the same period in the previous financial year because of an exceptional item amounting to \$28.8 million arising from the restructuring exercise.

#### 8(b)(ii) Detailed financial analysis for second quarter ended 30 September 2004

##### Operating Revenue

The segmental revenue and its composition are summarised below:

	2 <sup>nd</sup> Quarter 2004-05		2 <sup>nd</sup> Quarter 2003-04		% Change
	\$Million	%	\$Million	%	
Inflight catering	108.7	44.2	88.8	41.2	+ 22.4
Ground handling	108.2	44.0	104.3	48.5	+ 3.7
Security Services	18.5	7.5	13.8	6.4	+ 34.1
Others #	10.7	4.3	8.4	3.9	+ 27.3
<b>Total</b>	<b>246.1</b>	<b>100.0</b>	<b>215.3</b>	<b>100.0</b>	<b>+ 14.3</b>

# Other services include airline laundry services, cargo delivery, manufacturing and distribution of chilled and frozen processed food, and leasing of office space to airline clients and cargo agents.

The Group's operating revenue for the review period was \$246.1 million, an increase of 14.3% compared to \$215.3 million in the same period last year as airlines restored their flights to pre-SARS level.

Revenue from inflight catering went up 22.4% from \$88.8 million to \$108.7 million for the second quarter ended 30 September 2004 because of a 14.7% increase in the volume of inflight meals uplifted.

Revenue from ground handling increased 3.7% from \$104.3 million to \$108.2 million because of more flights handled and higher cargo volume handled in the current quarter.

Revenue from aviation security services rose 34.1% from \$13.8 million to \$18.5 million because of new security screening services rendered at the airport's gate hold room from September 2003.

Revenue from other services increased 27.3% from \$8.4 million to \$10.7 million.

### **Operating Expenditure**

Total operating expenditure for the Group increased \$32.5 million (+20.6%) to \$190.1 million for the second quarter in FY2004-05 compared to \$157.6 million in the same quarter last year.

Staff costs rose \$27.0 million (+35.8%) to \$102.5 million in the second quarter of FY04/05 compared to \$75.5 million in same period last year. The higher staff cost was mainly due to the provision for profit sharing bonus compared to nil provision in the same period last year, and higher overtime and allowances because of the rise in business volume.

The higher operating costs came also from a \$5.9 million (+35.1%) increase in cost of raw materials as a result of higher number of meals produced and higher prices of seafood, meat and poultry.

### **Profit Contribution from Associated Companies**

Profit contribution from overseas through associated companies increased 54.7% from \$8.6 million to \$13.3 million in the second quarter of FY04-05. This represents 19.1% of the Group's profit before tax and exceptional item, a 6.1 percentage points rise from the same period last year.

**9 Where a forecast, or a prospect statement, has been previously disclosed to shareholders, any variance between it and the actual results.**

Not applicable.

**10 A commentary at the date of the announcement of the significant trends and competitive conditions of the industry in which the group operates and any known factors or events that may affect the group in the next reporting period and the next 12 months.**

### **OUTLOOK FOR FY2004-05**

Flight frequencies and passenger loads for the second half of the financial year are expected to improve further. However, operating margins are expected to come under pressure due to increased competition.

In line with traffic growth, profit contribution from our associated companies is expected to improve.

The major workforce restructuring exercise in September 2004 has put the Group in a better position to meet the competition ahead.

**11 Dividends**

**(a) Current Financial Period Reported On**

Any dividend declared for the current financial period reported on? Yes

Name of dividend	Interim
Dividend type	Cash
Dividend amount per share	3 cents per ordinary share less tax
Dividend rate	30 %
Par value of shares	10 cents
Tax rate	20%

**(b) Corresponding Period of the Immediately Preceding Financial Year**

Any dividend declared for the corresponding period of the immediately preceding financial year?  
Yes

Name of dividend	Interim
Dividend type	Cash
Dividend amount per share	3 cents per ordinary share less tax
Dividend rate	30%
Par value of shares	10 cents
Tax rate	22%

**(c) Date Payable**

The interim dividend will be payable on 26 November 2004.

**(d) Books Closure Date**

Notice is hereby given that the Transfer Books and the Register of Members of the Company will be closed on 17 November 2004 for the preparation of dividend warrants. Duly completed and stamped transfers together with all relevant documents of or evidencing title received by the Company's Share Registrars, KPMG, at 138 Robinson Road #17-00, The Corporate Office, Singapore 068906, up to 5.00 pm on 16 November 2004 will be registered to determine shareholders' entitlements to the interim dividend. Subject as aforesaid, persons whose securities accounts with The Central Depository (Pte) Limited are credited with ordinary shares in the capital of the Company as at 5.00 pm on 16 November 2004 will be entitled to the interim dividend

**12 If no dividend has been declared/recommended, a statement to that effect.**

Not applicable.

### 13 Interested Person Transactions

13.1 The interested person transactions entered into during the second quarter ended 30 September 2004 of this financial year FY04/05 and the second quarter of the immediately preceding financial year FY03/04 are listed below:

Name of Interested Persons	Aggregate value of all interested person transactions entered into during the financial periods below (excluding transactions of value less than S\$100,000 and transactions under the shareholders' mandate pursuant to Rule 920 of the SGX-ST Listing Manual)		Aggregate value of all interested person transactions entered into during the financial periods below under the shareholders' mandate pursuant to Rule 920 of the SGX-ST Listing Manual (excluding transactions of value less than S\$100,000)	
	2 <sup>nd</sup> Quarter		2 <sup>nd</sup> Quarter	
	2004-05 \$'000	2003-04 \$'000	2004-05 \$'000	2003-04 \$'000
Singapore Airlines Limited	-	-	16,200	4,257
SES Systems Pte Ltd	-	-	891*	-
Singapore Food Industries Ltd	-	-	-	117
SembCorp Logistics Ltd	-	255	-	-
Total	-	255	17,091	4,374

\* includes amounts invoiced and paid in FY03/04

BY ORDER OF THE BOARD  
Annabelle Yip Wai Ping  
Company Secretary  
28 October 2004  
Singapore

Singapore Company Registration No: 197201770G



# SGX. Tomorrow's Market, Today

I want to go to .....

Prices | Products/Services | Listed Companies | Our Shareholders | Regulation | About SGX

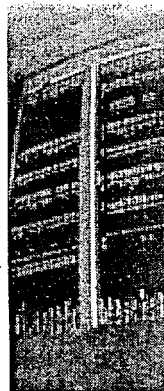

Home » Listed Companies » Announcements

## Announcements

- New Listings
- Annual Report/Fin. Report
- Company's All-In-One Info
- Research Reports
- AGM Schedules
- Prospectus/Circulars
- Announcements
- Stock/Indices List
- ISIN Code Download
- Corporate Info
- Corporate Action
- Warrants
- Tax Incentive Schemes
- Market Cap
- Sharebuyback Form

View Results By		
By Date (Recent Announcements)	By Company Name	By Category

Listed Companies' Announcements by Company Name :

A B C D E F G H I J K L M N O P Q R S T U V W X Y Z 0-9

Listed Companies' Announcement

Printer Friendly Version



SINGAPORE AIRPORT TERMINAL SERVICES LIMITED

## NEWS RELEASE : SECOND QUARTER REVENUE INCREASES WITH OPERATING PROFIT UNDER PRESSURE



SATS-News Release-2QFY05-FINAL.pdf

Submitted by Annabelle Yip Wai Ping, Company Secretary on 28 October 2004 to the SGX

Next Annc Prev Annc

All Rights Reserved. Copyright ) 2003, Singapore Exchange Ltd, Company Reg. No. 199904940D  
2 Shenton Way, #19-00 SGX Centre 1, Singapore 068804. Tel: (65) 6236 8888 Fax: (65) 6535 6994





No. 02/05

28 October 2004

## SECOND QUARTER REVENUE INCREASES WITH OPERATING PROFIT UNDER PRESSURE

### HIGHLIGHTS OF THE SATS GROUP'S RESULTS

	Half Year 2004-05	y.o.y. change (%)	2 <sup>nd</sup> Quarter 2004-05	y.o.y. change (%)
• Operating revenue	\$ 484.0M	+ 24.7	\$ 246.1M	+ 14.3
• Operating profit	\$ 106.3M	+ 31.7	\$ 56.0M	- 2.9
• Share of profits of associated companies	\$ 24.3M	+ 59.9	\$ 13.3M	+ 54.7
• Profit before tax	\$ 103.2M	+ 16.6	\$ 40.7M	- 38.7
• Profit attributable to shareholders	\$ 80.7M	+ 2.4	\$ 31.4M	- 38.3
• Earnings per share	8.0 cents	+ 1.3	3.1 cents	- 39.2
• Interim dividend per share declared: 3.0 cents				
• Exceptional item: One-time cost of the restructuring exercise in September 2004: \$28.8M				

**Note:** The SATS Group's unaudited financial results for the second quarter and first half ending 30 September 2004 were announced on 28 October 2004. A summary of the financial and operating statistics is shown in Annex A. (All monetary figures are in Singapore Dollars. The Group comprises the parent holding unit, its subsidiaries and associated companies).

**GROUP EARNINGS**First Half FY2004-05

Operating revenue in the first half of the year improved 24.7% compared to the same period last year, when SARS adversely affected air travel. Consequently, operating profit increased by 31.7% to \$106.3 million.

Profit contribution from our associated companies was \$24.3 million, an increase of \$9.1 million or 59.9% over the same period last year. Associated companies contributed 18.4% of our Group profit before tax and exceptional item.

After taking into account the one-time cost of the restructuring exercise in September 2004 of S\$28.8 million, profit before tax still showed a 16.6% increase to \$103.2 million.

Profit attributable to shareholders had a modest increase of \$1.9 million or 2.4% to \$80.7 million as there was a tax write-back of \$11.7 million last year.

Second Quarter FY2004-05

Operating revenue in the second quarter grew 14.3% or \$30.8 million, to \$246.1 million compared to the same quarter last year. Operating expenditure increased 20.6% or \$32.5 million, to \$190.1 million.

As a result, operating profit was \$56 million, a decrease of 2.9% over the same quarter last year. After taking into account the one-time cost of the restructuring of S\$28.8 million, profit before tax was 38.7% lower at \$40.7 million.

Profit contribution from our associated companies reached \$13.3 million, an increase of \$4.7 million or 54.7% over the same period last year. Associated companies contributed 19.1% of our Group profit before tax and exceptional item.

Profit attributable to shareholders declined 38.3% to \$31.4 million.

**GROUP FINANCIAL POSITION** (as at 30 September 2004)

Shareholders' funds of the Group stood at \$995.8 million.

Net asset value per share for the Group was 97.2 cents as at 30 September 2004, a decrease of 24.8 cents or 20.3% compared to 31 March 2004. This is due to the payment of net special dividends of 29.6 cents per share on 4 August 2004.

The Group's total assets increased by \$3.4 million (+0.2%) to \$1,562.0 million.

The debt equity ratio was 0.26 as at 30 September 2004, compared to 0.04 as at 31 March 2004, due to the issuance of S\$200 million 5-year fixed rate notes on 2 September 2004.

**GROUP OPERATING PERFORMANCE**

Operating data improved this financial year for both 1<sup>st</sup> Half and 2<sup>nd</sup> Quarter compared to the corresponding periods last financial year:

	1 <sup>st</sup> Half FY2004-05 (Apr-Sep 2004)	1 <sup>st</sup> Half FY2003-04 (Apr-Sep 2003)	% change
Passengers handled ('M)	12.35	8.89	+ 38.9
Meals produced ('M)	11.47	8.51	+ 34.8
Flights handled ('000)	36.85	28.29	+ 30.3
Cargo/mail processed ('000 tonnes)	713.90	676.60	+ 5.5
	2 <sup>nd</sup> Quarter FY2004-05 (Jul-Sep 2004)	2 <sup>nd</sup> Quarter FY2003-04 (Jul-Sep 2003)	% change
Passengers handled ('M)	6.34	5.66	+ 11.9
Meals produced ('M)	5.98	5.21	+ 14.7
Flights handled ('000)	18.72	15.17	+ 23.4
Cargo processed ('000 tonnes)	363.22	346.87	+ 4.7

## **INTERIM DIVIDENDS**

An interim dividend of 3 cents per share, amounting to \$24.6 million after tax, will be payable on 26 November 2004.

## **OUTLOOK**

Flight frequencies and passenger loads for the second half of the financial year are expected to improve further. However, operating margins are expected to come under pressure due to increased competition.

In line with traffic growth, profit contribution from our associated companies is expected to improve.

The major workforce restructuring exercise in September 2004 has put the Group in a better position to meet the competition ahead.

## **About Singapore Airport Terminal Services Limited (SATS)**

The Singapore Airport Terminal Services (SATS) Group is the leading provider of integrated ground handling and airline catering services at Singapore Changi Airport. SATS' network of ground handling and airline catering operations spans 13 overseas investments covering 23 airports in the Asia Pacific region. SATS' services include airfreight handling, airline catering, passenger services, baggage handling, ramp handling, aviation security, airline linen laundry and processed food manufacturing. SATS has been listed on the Singapore Exchange since May 2000.

## **Announcement information:**

The complete SATS Group's 2<sup>nd</sup> Quarter and Half Year FY2004-05 results are available on [www.sats.com.sg](http://www.sats.com.sg) and [www.irasia.com/listco/sg/sats/index.htm](http://www.irasia.com/listco/sg/sats/index.htm).

### Investor and Media Contacts:

Mah Tze Chiang  
Investor Relations Manager SATS  
Tel: (65) 6541-8150 (office hours)  
Tel: (65) 9047-7400 (after office hours)  
Fax: (65) 6541-8154  
Email: [tzechiang\\_mah@singaporeair.com.sg](mailto:tzechiang_mah@singaporeair.com.sg)

Evangelina Wee  
Gavin Anderson & Co  
Tel: (65) 6339-9110 (office hours)  
Tel: (65) 9873-5657 (after office hours)  
Fax: (65) 6339-9578  
Email: [ewee@gavinanderson.com.sg](mailto:ewee@gavinanderson.com.sg)

**GROUP FINANCIAL STATISTICS**

	1 <sup>st</sup> Half FY2004-05	1 <sup>st</sup> Half FY2003-04	2 <sup>nd</sup> Qtr FY2004-05	2 <sup>nd</sup> Qtr FY2003-04
<b>Financial Results (\$ million)</b>				
Total revenue	484.0	388.0	246.1	215.3
Total expenditure	(377.7)	(307.3)	(190.1)	(157.6)
Operating profit	106.3	80.7	56.0	57.7
Share of profits from associated companies	24.3	15.2	13.3	8.6
Profit before taxation and exceptional item	132.0	96.5	69.5	66.4
Exceptional item	(28.8)	(8.0)	(28.8)	-
Profit before taxation	103.2	88.5	40.7	66.4
Profit attributable to shareholders	80.7	78.8	31.4	50.9
Annualised return on average shareholders' funds (%) <sup>R1</sup>	14.6	15.2	11.2	18.0
Return on turnover (%)	16.7	20.3	12.8	23.6
<b>Per Share Data</b>				
Earnings after tax (cents) - basic <sup>R2</sup>	8.0	7.9	3.1	5.1
- diluted <sup>R3</sup>	7.9	7.9	3.1	5.1
<b>Financial Position (\$ million)</b>				
	As at 30 Sep 2004	As at 31 Mar 2004		
Share capital	102.4	100.6		
Share premium	38.7	8.7		
Distributable reserve	852.1	1,116.3		
Non-distributable reserve	2.6	2.5		
Shareholders' funds	995.8	1,228.1		
Total assets	1,562.0	1,558.6		
Total debt	254.6	49.7		
Total debt equity ratio (times) <sup>R4</sup>	0.26	0.04		
Net asset value per share (cents) <sup>R5</sup>	97.2	122.1		
<b>Dividends</b>				
Interim dividend declared (cents per share)	3.0	3.0		

<sup>R1</sup> Return on shareholders' fund is the profit after taxation and minority interests expressed as a percentage of the average shareholders' funds.

<sup>R2</sup> Earnings after tax per share (basic) is computed by dividing the profit after taxation and minority interests by the weighted average number of ordinary shares in issue.

<sup>R3</sup> Earnings after tax per share (diluted) is computed by dividing the profit after taxation and minority interests by the weighted average number of ordinary shares in issue after adjusting for the dilutive effect on the exercise of all outstanding share options granted to employees.

<sup>R4</sup> Total debt equity ratio is total debt divided by shareholders' funds.

<sup>R5</sup> Net asset value per share is computed by dividing shareholders' funds by the number of ordinary shares in issue at 30 September or 31 March.

**OPERATING STATISTICS**  
(April – September)

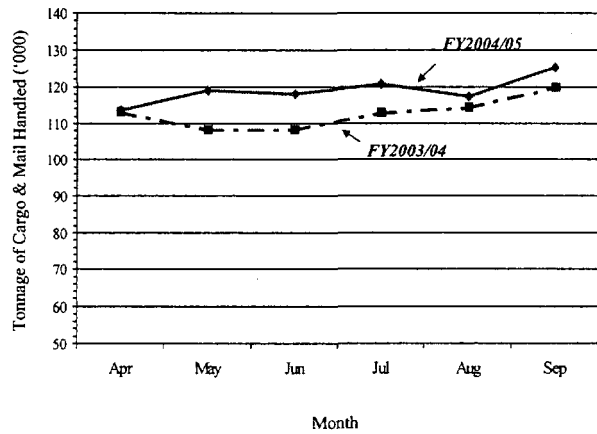
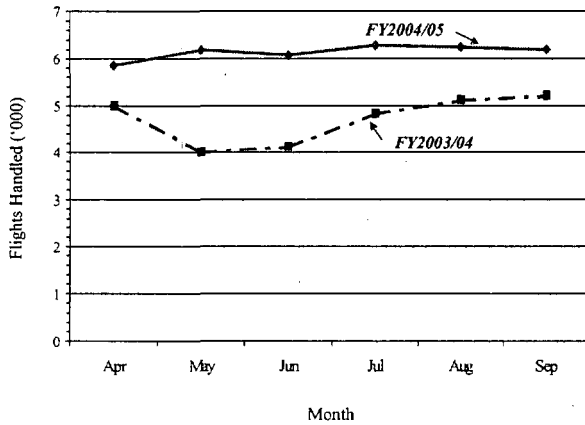
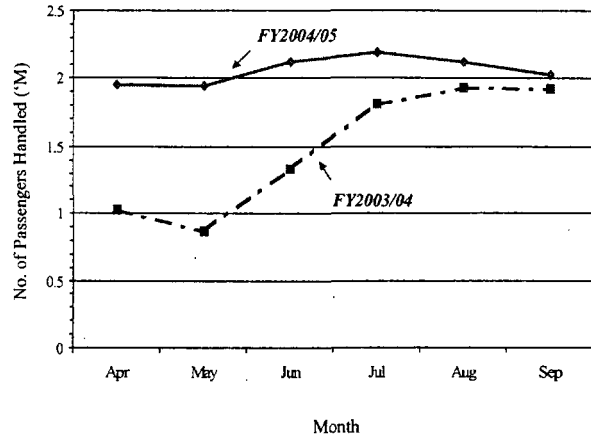
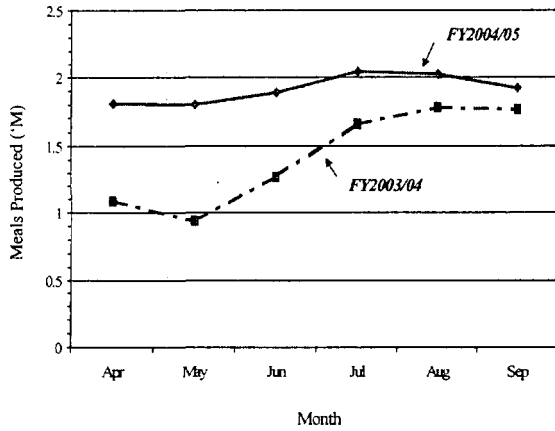



# SGX. Tomorrow's Market, Today

I want to go to .....

Prices | Products/Services | Listed Companies | Our Shareholders | Regulation | About SGX

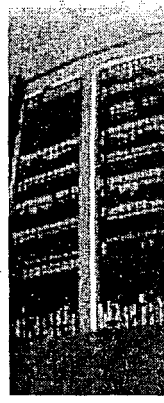

Home » Listed Companies » Announcements

## Announcements

- New Listings
- Annual Report/Fin. Report
- Company's All-In-One Info
- Research Reports
- AGM Schedules
- Prospectus/Circulars
- Announcements
- Stock/Indices List
- ISIN Code Download
- Corporate Info
- Corporate Action
- Warrants
- Tax Incentive Schemes
- Market Cap
- Sharebuyback Form

Announcements from 1 November 2004		
View Results By		
<a href="#">By Date (Recent Announcements)</a>	<a href="#">By Company Name</a>	<a href="#">By Category</a>

Announcements before 1 November 2004		
View Results By		
<a href="#">By Date (Recent Announcements)</a>	<a href="#">By Company Name</a>	<a href="#">By Category</a>

### Listed Companies' Announcements by Company Name :

A B C D E F G H I J K L M N O P Q R S T U V W X Y Z 0-9

Listed Companies' Announcement

Printer Friendly Version



SINGAPORE AIRPORT TERMINAL SERVICES LIMITED

## CHANGES TO BOARD COMMITTEES



Announcement (changes to Board Comms).doc  
Submitted by Annabelle Yip Wai Ping, Company Secretary on 25/10/2004 to the SGX

Next Annc Prev Annc

All Rights Reserved. Copyright) 2003. Singapore Exchange Ltd. Company Reg. No. 199904940D  
2 Shenton Way, #19-00 SGX Centre 1, Singapore 058804. Tel: (65) 6236 8888 Fax: (65) 6535 6994



## CHANGES TO BOARD COMMITTEES

Following a review by the Board of Directors of Singapore Airport Terminal Services Limited (the "Company") of the Company's Board Committees, the Company wishes to announce that the following changes have been made to its Board Committees, with effect from today:

1. The Audit Committee has been renamed the Audit and Risk Management Committee. The functions of the Board Risk Management Committee have been incorporated into the Charter of the Committee and the Board Risk Management Committee has been dissolved. Mr Chew Choon Seng has stepped down from, and Dr Ow Chin Hock and Mr Michael Tan have been appointed to, the Company's Audit Committee. The Board considers Dr Ow to be an independent Director, and Mr Tan, who retired as a senior executive of the Company's holding company Singapore Airlines Limited earlier this year, to be a non-independent Director. Mr Ng Kee Choe remains as Chairman and Dr Hong Hai remains as a member of the Committee. Both of them are considered by the Board to be independent Directors.
2. The Remuneration Committee has been renamed the Remuneration and Human Resource Committee, and its authority and functions have been expanded. It will now be chaired by Mr Edmund Cheng, with Mr Chew Choon Seng and Dr Richard Helfer as its members. Mr Michael Tan and Dr Hong Hai have stepped down from the Committee.
3. Dr Richard Helfer, Dr Hong Hai and Mr Michael Tan have been appointed as members of, and Mr Chew Choon Seng and Mr Ng Kee Choe have stepped down from, the Nominating Committee. Mr Barry Desker continues to be Chairman of the Nominating Committee.
4. The SATS Board Committee has been renamed the Board Executive Committee, being more reflective of the functions and authority of the Committee. Mr Ng Kee Choe will take the place of Mr Michael Tan as a member of the Committee. Mr Edmund Cheng and Mr Chew Choon Seng will remain as Chairman and member of the Committee respectively.
5. The Capital Structure Committee, a non-standing committee, has been dissolved as its functions have been completed.



# SGX. Tomorrow's Market, Today

I want to go to .....

Prices | Products/Services | Listed Companies | Our Shareholders | Regulation | About SGX

Home » Listed Companies » Announcements

## Announcements

- New Listings
- Annual Report/Fin. Report
- Company's All-in-One Info

- Research Reports
- AGM Schedules
- Prospectus/Circulars

- Announcements
- Stock/Indices List

- ISIN Code Download
- Corporate Info

- Corporate Action
- Warrants

- Tax Incentive Schemes
- Market Cap
- Sharebuyback Form

View Results By	
By Date (Recent Announcements)	By Company Name
By Category	

### Listed Companies' Announcements by Company Name :

A B C D E F G H I J K L M N O P Q R S T U V W X Y Z 0-9

Listed Companies' Announcement [Printer Friendly Version](#)



SINGAPORE AIRPORT TERMINAL SERVICES LIMITED

### Operating Data for September 2004



SATS-OperatingData-September2004.pdf

Submitted by Annabelle Yip, Company Secretary on 14/10/2004 to the SGX

[Next Annnc Prev Annnc](#)

---

All Rights Reserved. Copyright ) 2003. Singapore Exchange Ltd. Company Reg. No. 199904940D  
2 Shenton Way, #19-00 SGX Centre 1, Singapore 068804. Tel: (65) 6236 8888 Fax: (65) 6535 6994



This is the SATS operating data for September 2004:

Year on Year Comparison	September 2004	September 2003	% change
Unit Services Handled ('000)	6.44	5.70	+ 13.0
Flights Handled ('000)	6.19	5.21	+ 18.8
Cargo/Mail Processed ('000 tonnes)	125.16	119.61	+ 4.6
Passengers Handled ('M)	2.02	1.92	+ 5.1
Unit Meals Produced ('M)	1.51	1.39	+ 8.8
Gross Meals Produced ('M)	1.92	1.77	+ 8.5

2 <sup>nd</sup> Quarter comparison with 1 <sup>st</sup> Quarter FY2004-05	2Q FY2004-05 (Jul – Sep 04)	1Q FY2004-05 (Apr – Jun 04)	% change
Unit Services Handled ('000)	19.58	18.96	+ 3.3
Flights Handled ('000)	18.72	18.13	+ 3.2
Cargo/Mail Processed ('000 tonnes)	363.22	350.68	+ 3.6
Passengers Handled ('M)	6.34	6.01	+ 5.4
Unit Meals Produced ('M)	4.67	4.34	+ 7.7
Gross Meals Produced ('M)	5.98	5.49	+ 8.8

Note:

- \* unit services & flights handled - relate to Apron handling
- \*\* unit services represent workload handled by Apron staff - whereby each different aircraft/flight type (e.g. B744, A310, etc) is given a different unit service weightage factor.
- \*\*\* unit meals represent workload handled by Catering staff - whereby each meal type (e.g. dinner, lunch, etc) is given a different unit meal weightage factor.

Commentary:

Operating indices continued to improve in September 2004. All indices for the second quarter of FY2005 showed an improvement over the first quarter's data. Airlines have started to increase flights to cater for the expected passenger growth during the year-end holidays.

Issued by:  
 Investor Relations Dept  
 Singapore Airport Terminal Services Ltd (SATS)  
 Tel: 65-65418153  
 Fax: 65-65418154

## SINGAPORE AIRPORT TERMINAL SERVICES LIMITED

### Biz-Filing with Registry of Companies and Businesses

<u>Date of Filing</u>	<u>Form</u>
21 Dec 2004	Lodgment of Return of Allotment of Share – 5,200 shares
21 Dec 2004	Lodgment of Return of Allotment of Share – 5,800 shares
15 Dec 2004	Lodgment of Return of Allotment of Share – 18,200 shares
15 Dec 2004	Lodgment of Return of Allotment of Share – 5,200 shares
15 Dec 2004	Lodgment of Return of Allotment of Share – 7,800 shares
15 Dec 2004	Lodgment of Return of Allotment of Share – 20,800 shares
14 Dec 2004	Lodgment of Return of Allotment of Share – 15,600 shares
14 Dec 2004	Lodgment of Return of Allotment of Share – 15,600 shares
06 Dec 2004	Lodgment of Return of Allotment of Share – 2,600 shares
06 Dec 2004	Lodgment of Return of Allotment of Share – 2,600 shares
01 Dec 2004	Lodgment of Return of Allotment of Share – 2,600 shares
01 Dec 2004	Lodgment of Return of Allotment of Share – 7,800 shares
01 Dec 2004	Lodgment of Return of Allotment of Share – 2,600 shares
30 Nov 2004	Lodgment of Return of Allotment of Share – 7,800 shares
30 Nov 2004	Lodgment of Return of Allotment of Share – 2,600 shares
24 Nov 2004	Lodgment of Return of Allotment of Share – 13,000 shares
24 Nov 2004	Lodgment of Return of Allotment of Share – 5,200 shares
22 Nov 2004	Lodgment of Return of Allotment of Share – 5,200 shares
22 Nov 2004	Lodgment of Return of Allotment of Share – 2,600 shares

10 Nov 2004	Lodgment of Return of Allotment of Share –	28,600 shares
10 Nov 2004	Lodgment of Return of Allotment of Share –	13,000 shares
10 Nov 2004	Lodgment of Return of Allotment of Share –	13,000 shares
10 Nov 2004	Lodgment of Return of Allotment of Share –	2,600 shares
10 Nov 2004	Lodgment of Return of Allotment of Share –	3,200 shares
08 Nov 2004	Lodgment of Return of Allotment of Share –	20,800 shares
08 Nov 2004	Lodgment of Return of Allotment of Share –	15,600 shares
08 Nov 2004	Lodgment of Return of Allotment of Share –	6,500 shares
05 Nov 2004	Lodgment of Return of Allotment of Share –	7,800 shares
05 Nov 2004	Lodgment of Return of Allotment of Share –	2,600 shares
05 Nov 2004	Lodgment of Return of Allotment of Share –	2,600 shares
04 Nov 2004	Lodgment of Return of Allotment of Share –	15,600 shares
04 Nov 2004	Lodgment of Return of Allotment of Share –	13,000 shares
04 Nov 2004	Lodgment of Return of Allotment of Share –	39,450 shares
04 Nov 2004	Lodgment of Return of Allotment of Share –	18,200 shares
04 Nov 2004	Lodgment of Return of Allotment of Share –	5,200 shares
02 Nov 2004	Lodgment of Return of Allotment of Share –	2,600 shares
02 Nov 2004	Lodgment of Return of Allotment of Share –	2,600 shares
02 Nov 2004	Lodgment of Return of Allotment of Share –	2,600 shares
01 Nov 2004	Lodgment of Return of Allotment of Share –	11,600 shares
01 Nov 2004	Lodgment of Return of Allotment of Share –	2,600 shares
01 Nov 2004	Lodgment of Return of Allotment of Share –	2,600 shares

**RECEIPT**

Receipt No : ACR0000000980557A

Date/Time : 21/12/2004 15:24

Transaction No : C040561573

Agency : RCB - RCB

Application : BIZFILE PAYMENT SERVICE

Paid via : Deposit Service Account

EP Ref No :

**SINGAPORE AIRPORT TERMINAL SERVICES LIMITED****20 AIRPORT BOULEVARD****SATS INFLIGHT CATERING CENTRE 3****SINGAPORE 819659**

---

<b>Sno</b>	<b>Code/Description</b>	<b>Unit Price (S\$)</b>	<b>Qty</b>	<b>Amount</b>
1	Lodgment Of Return Of Allotment Of Share <b>COMPANY/BUSINESS NAME :</b> 197201770G / SINGAPORE AIRPORT TERMINAL SERVICES LIMITED	10.00	1	10.00
<b>Total (S\$) :</b>				<b>10.00</b>

---

**Deposit Service Account No. : 030066**  
**Balance Amount in Deposit Account : \$ 85.00**

This is a computer-generated receipt. No signature is required.

Please print a copy of the receipt for your reference.

[HOME](#)[LOGOUT](#)

**LOCAL COMPANY TRANSACTIONS****Return of Allotment of Shares**

Please fill in the following information. Fields marked \* must be completed.

Resolution/Declaration	Shares payable in cash	For a consideration other than cash	Share Capital/Allottees Particulars	List of Shareholders after the allotment	Summary of Capital
------------------------	------------------------	-------------------------------------	-------------------------------------	--	--------------------

**Company Type**

Please click on appropriate button :

- company is listed on the securities exchange  
 company is an unlisted public company  
 company is a private company

**Power under Section 161 of the Companies Act \***

The directors have obtained the approval of the company in general meeting to issue shares.  
 Yes  
 No

**Resolution Made**

\* You are only required to fill in this section if the directors are not given the power under Section 161 of the Companies Act to issue shares.

Registration No. : **197201770G**Company Name : **SINGAPORE AIRPORT TERMINAL SERVICES LIMITED**Nature of Meeting : \* 

Place of Meeting : \*

Date of Meeting : \*  (dd/mm/yyyy)Resolution Type : \* Description : \*  
(max 2000 characters)Attachment : \*  
(copy of resolution)**Note :**

Uploaded file name will be changed by suffixing time-stamp with the actual file name as **filenameyyyyMMddmmsstt**  
 Maximum File Size : 2048 KB

(Click 'Browse' to select file for attachment)

**Persons signing the resolution**

Please indicate the directors/ secretaries who signed the resolution :

 S0036442H / OW CHIN HOCK



- S0070715E / NG KEE CHOE
- S0234645A / CHEW CHOON SENG
- S1001765C / BARRY HENRY PATRICK DESKER
- S1069567H / TAN JIAK NGEE MICHAEL
- S1673157I / YIP WAI PING ANNABELLE
- S1852301I / HONG HAI @ HUANG HAI
- S2163476Z / CHENG WAI WING EDMUND
- S2580327B / RICHARD CHARLES HELFER

Please enter names of other corporate representatives who signed the resolution, if applicable :

**Declaration**

I, SHIREENA JOHAN WOON, Professional body/service bureau, declare the information which has been submitted herein to be true to the best of my knowledge.

**Return of Allotment of Shares**

Submit

Please fill in the following information. Fields marked \* must be completed.

Resolution / Declaration	Share payable in cash	For a consideration other than cash	Share Capital / Allottees Particulars	List of Shareholders after the Allotment	Summary of Capital
--------------------------	-----------------------	-------------------------------------	---------------------------------------	--	--------------------

**Authorised Capital**

	Amount	Nominal Value per Share	Currency
Authorised Capital :	<b>20000000</b>	<b>.1</b>	<b>SINGAPORE DOLLAR ( 099 )</b>

Description of discrepancy :

**Return of Allotment of Shares (Payable in cash) \***

Applicable only if share is payable in cash

Class of Shares :	Ordinary	Preference	Others
Number of shares :	5200		
Amount paid or due and payable on each share			
paid :	0.10		
due and payable :	0		
Amount of premium paid or payable on each share :	1.50		

Save

Delete Issued Share

Reset

Back

**Return of Allotment of Shares**

Submit

Please fill in the following information. Fields marked \* must be completed.

Resolution / Declaration	Share payable in cash	For a consideration other than cash	Share Capital / Allottees Particulars	List of Shareholders after the allotment	Summary of Capital
<b>Share Capital (1)</b>					
Currency :	<b>SINGAPORE DOLLAR (099)</b>				
Nominal Value per Share :	<b>0.10</b>				
Amount of Authorised Share Capital :	<b>200000000.00</b>				
Class of Shares :	Ordinary	Preference	Others		
Amount of Issued Share Capital :	<b>102615182.50</b>	<b>0.00</b>	<b>0.00</b>		
Amount of Paid-up Share Capital :	<b>102615182.50</b>	<b>0.00</b>	<b>0.00</b>		

**RECEIPT**

Receipt No : ACR0000000980530A  
Transaction No : C040561537  
Agency : RCB - RCB  
Application : BIZFILE PAYMENT SERVICE  
Paid via : Deposit Service Account  
EP Ref No :

Date/Time : 21/12/2004 15:13

**SINGAPORE AIRPORT TERMINAL SERVICES LIMITED**  
**20 AIRPORT BOULEVARD**  
**SATS INFLIGHT CATERING CENTRE 3**  
**SINGAPORE 819659**

Sno	Code/Description	Unit Price (S\$)	Qty	Amount
1	Lodgment Of Return Of Allotment Of Share <b>COMPANY/BUSINESS NAME :</b> 197201770G / SINGAPORE AIRPORT TERMINAL SERVICES LIMITED	10.00	1	10.00
			Total (S\$) :	10.00

**Deposit Service Account No. : 030066**  
**Balance Amount in Deposit Account : \$ 95.00**

This is a computer-generated receipt. No signature is required.

Please print a copy of the receipt for your reference.

[HOME](#)[LOGOUT](#)

**LOCAL COMPANY TRANSACTIONS****Return of Allotment of Shares**

Submit

Please fill in the following information. Fields marked \* must be completed.

Resolution/Declaration	Shares payable in cash	For a consideration other than cash	Share Capital/Allottees Particulars	List of Shareholders after the allotment	Summary of Capital
------------------------	------------------------	-------------------------------------	-------------------------------------	--	--------------------

**Company Type**

Please click on appropriate button :

- company is listed on the securities exchange  
 company is an unlisted public company  
 company is a private company

**Power under Section 161 of the Companies Act \***

The directors have obtained the approval of the company in general meeting to issue shares.

Yes  
 No

**Resolution Made**

\* You are only required to fill in this section if the directors are not given the power under Section 161 of the Companies Act to issue shares.

Registration No. : **197201770G**Company Name : **SINGAPORE AIRPORT TERMINAL SERVICES LIMITED**Nature of Meeting : \* **Members**

Place of Meeting : \*

Date of Meeting : \* (dd/mm/yyyy)

Resolution Type : \* **Ordinary**Description : \*  
(max 2000 characters)Attachment : \*  
(copy of resolution)

Browse...

**Note :**

Uploaded file name will be changed by suffixing time-stamp with the actual file name as **filenameyyyyMMddmmsstt**  
Maximum File Size : 2048 KB

(Click 'Browse' to select file for attachment)

**Persons signing the resolution**

Please indicate the directors/ secretaries who signed the resolution :

 S0036442H / OW CHIN HOCK

- S0070715E / NG KEE CHOE
- S0234645A / CHEW CHOON SENG
- S1001765C / BARRY HENRY PATRICK DESKER
- S1069567H / TAN JIAK NGEEN MICHAEL
- S1673157I / YIP WAI PING ANNABELLE
- S1852301I / HONG HAI @ HUANG HAI
- S2163476Z / CHENG WAI WING EDMUND
- S2580327B / RICHARD CHARLES HELFER

Please enter names of other corporate representatives who signed the resolution, if applicable :

**Declaration**

I, SHIREENA JOHAN WOON, Professional body/service bureau, declare the information which has been submitted herein to be true to the best of my knowledge.

Save	Reset
------	-------

**Return of Allotment of Shares**

Submit

Please fill in the following information. Fields marked \* must be completed.

Resolution / Declaration	Share payable in cash	For a consideration other than cash	Share Capital / Allottees Particulars	List of Shareholders after the Allotment	Summary of Capital
--------------------------	-----------------------	-------------------------------------	---------------------------------------	--	--------------------

**Authorised Capital**

	Amount	Nominal Value per Share	Currency
Authorised Capital :	<b>20000000</b>	<b>.1</b>	<b>SINGAPORE DOLLAR ( 099 )</b>

Description of discrepancy :

**Return of Allotment of Shares (Payable in cash) \***

Applicable only if share is payable in cash

Class of Shares :	Ordinary	Preference	Others
Number of shares :	5800		
Amount paid or due and payable on each share			
paid :	0.10		
due and payable :	0		
Amount of premium paid or payable on each share :	1.14		

Save

Delete Issued Share

Reset

Back

**Return of Allotment of Shares**

Submit

Please fill in the following information. Fields marked \* must be completed.

Resolution / Declaration	Share payable in cash	For a consideration other than cash	Share Capital / Allottees Particulars	List of Shareholders after the allotment	Summary of Capital
--------------------------	-----------------------	-------------------------------------	---------------------------------------	--	--------------------

**Particulars of Allottee**

Please indicate whether the allottee is an Individual : \*

- Allottee is an Individual  
 Allottee is NOT an Individual

**If Allottee is an Individual :**

Shareholder Category : \*

**Individual**

Identification No. : \*

Retrieve Details

Identification Type : \*

NRIC

Name : \*

Nationality : \*

Mobile No :

Occupation :

Email Address :

Address Type : \*

- Local  
 Foreign

Local Address (\* if Address Type is Local Address)

Postal Code : 

Retrieve Address

Block/House No. : 

Street Name :

Unit : #  - 

Building/Estate Name :

Foreign Address (\* if Address Type is Foreign Address)

Address : **If Allottee is NOT an Individual :**

Shareholder Category : \*

Company / Foreign Branch

Search



Registration No. : \*

198003912M

Retrieve Details

Name :

THE CENTRAL DEPOSITORY (PTE) LIMITED

Address Type :

Local

Local Address (\* if Address Type is Local Address)

Postal Code : 068804

Block/House No. : 2

Street Name : SHENTON WAY

Unit : # 19 - 00

Building/Estate Name : SGX CENTRE I

Foreign Address (\* if Address Type is Foreign Address)

Address :

**Details of Shares Allotted** \* Please read instructions carefully before entering.

Note : If any share or shares is/are co-owned by 2 or more persons, please assign an alphabet e.g. A to denote the Group and enter the same in the box. Enter the same alphabet in the box for every allottee in the same group. Skip this box if share(s) are owned by only one person.

Group of Share that is co-owned:  
(Share Group)

If share(s) is/are co-owned, only one allottee is to enter details in (a), (b), (c), (d) and (e). Enter "0" (zero) for subsequent allottees in box (b) and leave blank for rest of the items.

a) Nominal Value per Share :

0.10

b) No. of shares allotted :

5800

c) Class of shares allotted :

Ordinary

d) Currency :

SINGAPORE DOLLAR (099)

e) Date of allotment :

16/12/2004 (dd/mm/yyyy)

Save

Reset

Back

**LOCAL COMPANY TRANSACTIONS****Return of Allotment of Shares**

Submit

Please fill in the following information. Fields marked \* must be completed.

<b>Resolution / Declaration</b>	<b>Share payable in cash</b>	<b>For a consideration other than cash</b>	<b>Share Capital / Allottees Particulars</b>	<b>List of Shareholders after the allotment</b>	<b>Summary of Capital</b>
-------------------------------------	------------------------------	--	--	---	-------------------------------

**Share Capital (1)**

Currency :	<b>SINGAPORE DOLLAR (099)</b>		
Nominal Value per Share :	<b>0.10</b>		
Amount of Authorised Share Capital :	<b>200000000.00</b>		
Class of Shares :	Ordinary	Preference	Others
Amount of Issued Share Capital :	<b>102614662.50</b>	<b>0.00</b>	<b>0.00</b>
Amount of Paid-up Share Capital :	<b>102614662.50</b>	<b>0.00</b>	<b>0.00</b>

GST No. :M9-0008879-T

**RECEIPT**

Receipt No : ACR0000000972881A

Date/Time : 15/12/2004 10:34

Transaction  
No : C040553326

Agency : RCB - RCB

Application : BIZFILE PAYMENT SERVICE

Paid via : Deposit Service Account

EP Ref No :

**SINGAPORE AIRPORT TERMINAL SERVICES LIMITED****20 AIRPORT BOULEVARD****SATS INFLIGHT CATERING CENTRE 3****SINGAPORE 819659**

---

Sno	Code/Description	Unit Price (S\$)	Qty	Amount
1	Lodgment Of Return Of Allotment Of Share <b>COMPANY/BUSINESS NAME :</b> 197201770G / SINGAPORE AIRPORT TERMINAL SERVICES LIMITED	10.00	1	10.00
Total (S\$) :				10.00

---

**Deposit Service Account No. : 030066****Balance Amount in Deposit Account : \$ 105.00**

This is a computer-generated receipt. No signature is required.

Please print a copy of the receipt for your reference.

[HOME](#)[LOGOUT](#)

**Submit****Return of Allotment of Shares**

Please fill in the following information. Fields marked \* must be completed.

Resolution/Declaration	Shares payable in cash	For a consideration other than cash	Share Capital/Allottees Particulars	List of Shareholders after the allotment	Summary of Capital
------------------------	------------------------	-------------------------------------	-------------------------------------	--	--------------------

**Company Type**

- Please click on appropriate button :
- company is listed on the securities exchange
  - company is an unlisted public company
  - company is a private company

**Power under Section 161 of the Companies Act \***

The directors have obtained the approval of the company in general meeting to issue shares.

Yes  
 No

**Resolution Made**

\* You are only required to fill in this section if the directors are not given the power under Section 161 of the Companies Act to issue shares.

Registration No. : **197201770G**

Company Name : **SINGAPORE AIRPORT TERMINAL SERVICES LIMITED**

Nature of Meeting : \* Place of Meeting : \* Date of Meeting : \*  (dd/mm/yyyy)Resolution Type : \* Description : \* (max 2000 characters) Attachment : \* (copy of resolution)  **Browse...**

**Note :**  
 Uploaded file name will be changed by suffixing time-stamp with the actual file name as **filenameyyyyMMddmmsstt**  
 Maximum File Size : 2048 KB

(Click 'Browse' to select file for attachment)

**Persons signing the resolution**

Please indicate the directors/ secretaries who signed the resolution :

S0036442H / OW CHIN HOCK

- S0070715E / NG KEE CHOE
- S0234645A / CHEW CHOON SENG
- S1001765C / BARRY HENRY PATRICK DESKER
- S1069567H / TAN JIAK NGEE MICHAEL
- S1673157I / YIP WAI PING ANNABELLE
- S1852301I / HONG HAI @ HUANG HAI
- S2163476Z / CHENG WAI WING EDMUND
- S2580327B / RICHARD CHARLES HELFER

Please enter names of other corporate representatives who signed the resolution, if applicable :

**Declaration**

I, SHIREENA JOHAN WOON, Professional body/service bureau, declare the information which has been submitted herein to be true to the best of my knowledge.

Save	Reset
------	-------

**Return of Allotment of Shares**

Submit

Please fill in the following information. Fields marked \* must be completed.

Resolution / Declaration	Share payable in cash	For a consideration other than cash	Share Capital / Allottees Particulars	List of Shareholders after the Allotment	Summary of Capital
--------------------------	-----------------------	-------------------------------------	---------------------------------------	--	--------------------

**Authorised Capital**

	Amount	Nominal Value per Share	Currency
Authorised Capital :	<b>200000000</b>	<b>.1</b>	<b>SINGAPORE DOLLAR ( 099 )</b>

Description of discrepancy :

**Return of Allotment of Shares (Payable in cash) \***

Applicable only if share is payable in cash

Class of Shares :	Ordinary	Preference	Others
Number of shares :	18200		
Amount paid or due and payable on each share			
paid :	0.10		
due and payable :	0		
Amount of premium paid or payable on each share :	1.50		

Save

Delete Issued Share

Reset

Back

**Return of Allotment of Shares****Submit**

Please fill in the following information. Fields marked \* must be completed.

Resolution / Declaration	Share payable in cash	For a consideration other than cash	Share Capital / Allottees Particulars	List of Shareholders after the allotment	Summary of Capital
--------------------------	-----------------------	-------------------------------------	---------------------------------------	--	--------------------

**Particulars of Allottee****Please indicate whether the allottee is an Individual : \***

- Allottee is an Individual
- Allottee is NOT an Individual

**If Allottee is an Individual :**

Shareholder Category : \*

**Individual**

Identification No. : \*

 **Retrieve Details**

Identification Type : \*

Name : \*

Nationality : \*

Mobile No :

Occupation :

Email Address :

Address Type : \*

- Local
- Foreign

Local Address (\* if Address Type is Local Address)

Postal Code :  **Retrieve Address**Block/House No. : 

Street Name :

Unit : #  - 

Building/Estate Name :

Foreign Address (\* if Address Type is Foreign Address)

Address :   
**If Allottee is NOT an Individual :**

Shareholder Category : \*

 **Search**

Name :

**THE CENTRAL DEPOSITORY (PTE) LIMITED**

Address Type :

**Local**

Local Address (\* if Address Type is Local Address)

Postal Code : **068804**Block/House No. : **2**Street Name : **SHENTON WAY**Unit : # **19 - 00**Building/Estate Name : **SGX CENTRE I**

Foreign Address (\* if Address Type is Foreign Address)

Address :

**Details of Shares Allotted** \* Please read instructions carefully before entering.

Note : If any share or shares is/are co-owned by 2 or more persons, please assign an alphabet e.g. A to denote the Group and enter the same in the box. Enter the same alphabet in the box for every allottee in the same group. Skip this box if share(s) are owned by only one person.

Group of Share that is co-owned:  
(Share Group)

If share(s) is/are co-owned, only one allottee is to enter details in (a), (b), (c), (d) and (e). Enter "0" (zero) for subsequent allottees in box (b) and leave blank for rest of the items.

a) Nominal Value per Share :

b) No. of shares allotted :

c) Class of shares allotted :

d) Currency :

e) Date of allotment :

 (dd/mm/yyyy)



**Return of Allotment of Shares**

Submit

Please fill in the following information. Fields marked \* must be completed.

Resolution / Declaration	Share payable in cash	For a consideration other than cash	Share Capital / Allottees Particulars	List of Shareholders after the allotment	Summary of Capital
<b>Share Capital (1)</b>					
Currency :	<b>SINGAPORE DOLLAR (099)</b>				
Nominal Value per Share :	<b>0.10</b>				
Amount of Authorised Share Capital :	<b>200000000.00</b>				
Class of Shares :	Ordinary	Preference	Others		
Amount of Issued Share Capital :	<b>102614082.50</b>	<b>0.00</b>	<b>0.00</b>		
Amount of Paid-up Share Capital :	<b>102614082.50</b>	<b>0.00</b>	<b>0.00</b>		

**RECEIPT**

Receipt No : ACR0000000972850A

Date/Time : 15/12/2004 10:24

Transaction No : C040553297

Agency : RCB - RCB

Application : BIZFILE PAYMENT SERVICE

Paid via : Deposit Service Account

EP Ref No :

**SINGAPORE AIRPORT TERMINAL SERVICES LIMITED****20 AIRPORT BOULEVARD****SATS INFLIGHT CATERING CENTRE 3****SINGAPORE 819659**

---

Sno	Code/Description	Unit Price (\$)	Qty	Amount
1	Lodgment Of Return Of Allotment Of Share <b>COMPANY/BUSINESS NAME :</b> 197201770G / SINGAPORE AIRPORT TERMINAL SERVICES LIMITED	10.00	1	10.00
Total (S\$) :				10.00

---

**Deposit Service Account No. : 030066****Balance Amount in Deposit Account : \$ 115.00**

This is a computer-generated receipt. No signature is required.

Please print a copy of the receipt for your reference.

[HOME](#)[LOGOUT](#)

**LOCAL COMPANY TRANSACTIONS****Return of Allotment of Shares**

Submit

Please fill in the following information. Fields marked \* must be completed.

Resolution/Declaration	Shares payable in cash	For a consideration other than cash	Share Capital/Allottees Particulars	List of Shareholders after the allotment	Summary of Capital
------------------------	------------------------	-------------------------------------	-------------------------------------	--	--------------------

**Company Type**

Please click on appropriate button :

- company is listed on the securities exchange  
 company is an unlisted public company  
 company is a private company

**Power under Section 161 of the Companies Act \***

The directors have obtained the approval of the company in general meeting to issue shares.

Yes  
 No

**Resolution Made**

\* You are only required to fill in this section if the directors are not given the power under Section 161 of the Companies Act to issue shares.

Registration No. : **197201770G**Company Name : **SINGAPORE AIRPORT TERMINAL SERVICES LIMITED**Nature of Meeting : \* **Members** ▼

Place of Meeting : \*

Date of Meeting : \* (dd/mm/yyyy)

Resolution Type : \* **Ordinary** ▼Description : \*  
(max 2000 characters)Attachment : \*  
(copy of resolution)

**Note :**  
 Uploaded file name will be changed by suffixing time-stamp with the actual file name as **filenameyyyyMMddmmsstt**  
 Maximum File Size : 2048 KB

(Click 'Browse' to select file for attachment)

**Persons signing the resolution**

Please indicate the directors/ secretaries who signed the resolution :

☐ S0036442H / OW CHIN HOCK

- S0070715E / NG KEE CHOE
- S0234645A / CHEW CHOON SENG
- S1001765C / BARRY HENRY PATRICK DESKER
- S1069567H / TAN JIAK NGEE MICHAEL
- S1673157I / YIP WAI PING ANNABELLE
- S1852301I / HONG HAI @ HUANG HAI
- S2163476Z / CHENG WAI WING EDMUND
- S2580327B / RICHARD CHARLES HELFER

Please enter names of other corporate representatives who signed the resolution, if applicable :

**Declaration**

I, SHIREENA JOHAN WOON, Professional body/service bureau, declare the information which has been submitted herein to be true to the best of my knowledge.

Save	Reset
------	-------

**Return of Allotment of Shares**

Submit

Please fill in the following information. Fields marked \* must be completed.

Resolution / Declaration	Share payable in cash	For a consideration other than cash	Share Capital / Allottees Particulars	List of Shareholders after the Allotment	Summary of Capital
--------------------------	-----------------------	-------------------------------------	---------------------------------------	--	--------------------

**Authorised Capital**

	Amount	Nominal Value per Share	Currency
Authorised Capital :	<b>200000000</b>	<b>.1</b>	<b>SINGAPORE DOLLAR ( .099 )</b>

Description of discrepancy :

**Return of Allotment of Shares (Payable in cash) \***

Applicable only if share is payable in cash

Class of Shares :	Ordinary	Preference	Others
Number of shares :	5200		
Amount paid or due and payable on each share			
paid :	0.10		
due and payable :	0		
Amount of premium paid or payable on each share :	1.14		

Save

Delete Issued Share

Reset

Back

**Return of Allotment of Shares**

Submit

Please fill in the following information. Fields marked \* must be completed.

Resolution / Declaration	Share payable in cash	For a consideration other than cash	Share Capital / Allottees Particulars	List of Shareholders after the allotment	Summary of Capital
-----------------------------	-----------------------	--	--	---	-----------------------

**Particulars of Allottee**

Please indicate whether the allottee is an Individual : \*

- Allottee is an Individual  
 Allottee is NOT an Individual

**If Allottee is an Individual :**

Shareholder Category : \*

**Individual**

Identification No. : \*

Retrieve Details

Identification Type : \*

NRIC

Name : \*

Nationality : \*

Mobile No :

Occupation :

Email Address :

Address Type : \*

- Local  
 Foreign

Local Address (\* if Address Type is Local Address)

Postal Code :

Retrieve Address

Block/House No. :

Street Name :

Unit : #

Building/Estate Name :

Foreign Address (\* if Address Type is Foreign Address)

Address :

**If Allottee is NOT an Individual :**

Shareholder Category : \*

Company / Foreign Branch

Search

Registration No. : \*

198003912M

Retrieve Details

Name :

**THE CENTRAL DEPOSITORY (PTE) LIMITED**

Address Type :

**Local**

Local Address (\* if Address Type is Local Address)

Postal Code : **068804**

Block/House No. : **2**

Street Name : **SHENTON WAY**

Unit : # **19 - 00**

Building/Estate Name : **SGX CENTRE I**

Foreign Address (\* if Address Type is Foreign Address)

Address :

**Details of Shares Allotted** \* Please read instructions carefully before entering.

Note : If any share or shares is/are co-owned by 2 or more persons, please assign an alphabet e.g. A to denote the Group and enter the same in the box. Enter the same alphabet in the box for every allottee in the same group. Skip this box if share(s) are owned by only one person.

Group of Share that is co-owned:  
(Share Group)

If share(s) is/are co-owned, only one allottee is to enter details in (a), (b), (c), (d) and (e). Enter "0" (zero) for subsequent allottees in box (b) and leave blank for rest of the items.

a) Nominal Value per Share :

0.10

b) No. of shares allotted :

5200

c) Class of shares allotted :

Ordinary

d) Currency :

SINGAPORE DOLLAR (099)

e) Date of allotment :

09/12/2004 (dd/mm/yyyy)

Save

Reset

Back

**Return of Allotment of Shares**

Submit

Please fill in the following information. Fields marked \* must be completed.

Resolution / Declaration	Share payable in cash	For a consideration other than cash	Share Capital / Allottees Particulars	List of Shareholders after the allotment	Summary of Capital
<b>Share Capital (1)</b>					
Currency :	<b>SINGAPORE DOLLAR (099)</b>				
Nominal Value per Share :	<b>0.10</b>				
Amount of Authorised Share Capital :	<b>200000000.00</b>				
Class of Shares :	Ordinary	Preference	Others		
Amount of Issued Share Capital :	<b>102612262.50</b>	<b>0.00</b>	<b>0.00</b>		
Amount of Paid-up Share Capital :	<b>102612262.50</b>	<b>0.00</b>	<b>0.00</b>		



GST No. :M9-0008879-T

**RECEIPT**

Receipt No : ACR0000000972751A

Date/Time : 15/12/2004 09:51

Transaction  
No : C040553205

Agency : RCB - RCB

Application : BIZFILE PAYMENT SERVICE

Paid via : Deposit Service Account

EP Ref No :

**SINGAPORE AIRPORT TERMINAL SERVICES LIMITED****20 AIRPORT BOULEVARD****SATS INFLIGHT CATERING CENTRE 3****SINGAPORE 819659**

---

Sno	Code/Description	Unit Price (S\$)	Qty	Amount
1	Lodgment Of Return Of Allotment Of Share <b>COMPANY/BUSINESS NAME :</b> 197201770G / SINGAPORE AIRPORT TERMINAL SERVICES LIMITED	10.00	1	10.00
Total (S\$) :				10.00

---

**Deposit Service Account No. : 030066**  
**Balance Amount in Deposit Account : \$ 125.00**

This is a computer-generated receipt. No signature is required.

Please print a copy of the receipt for your reference.

[HOME](#)[LOGOUT](#)

**LOCAL COMPANY TRANSACTIONS****Return of Allotment of Shares**

Submit

Please fill in the following information. Fields marked \* must be completed.

Resolution/Declaration	Shares payable in cash	For a consideration other than cash	Share Capital/Allottees Particulars	List of Shareholders after the allotment	Summary of Capital
------------------------	------------------------	-------------------------------------	-------------------------------------	--	--------------------

**Company Type**

Please click on appropriate button :

- company is listed on the securities exchange  
 company is an unlisted public company  
 company is a private company

**Power under Section 161 of the Companies Act \***

The directors have obtained the approval of the company in general meeting to issue shares.

Yes  
 No

**Resolution Made**

\* You are only required to fill in this section if the directors are not given the power under Section 161 of the Companies Act to issue shares.

Registration No. : **197201770G**Company Name : **SINGAPORE AIRPORT TERMINAL SERVICES LIMITED**Nature of Meeting : \* **Members**

Place of Meeting : \*

Date of Meeting : \* (dd/mm/yyyy)

Resolution Type : \* **Ordinary**Description : \*  
(max 2000 characters)Attachment : \*  
(copy of resolution)

Browse...

**Note :**  
 Uploaded file name will be changed by suffixing time-stamp with the actual file name as **filenameyyyyMMddmmsstt**  
 Maximum File Size : 2048 KB

(Click 'Browse' to select file for attachment)

**Persons signing the resolution**

Please indicate the directors/ secretaries who signed the resolution :

 S0036442H / OW CHIN HOCK

- S0070715E / NG KEE CHOE
- S0234645A / CHEW CHOON SENG
- S1001765C / BARRY HENRY PATRICK DESKER
- S1069567H / TAN JIAK NGEN MICHAEL
- S1673157I / YIP WAI PING ANNABELLE
- S1852301I / HONG HAI @ HUANG HAI
- S2163476Z / CHENG WAI WING EDMUND
- S2580327B / RICHARD CHARLES HELFER

Please enter names of other corporate representatives who signed the resolution, if applicable :

**Declaration**

I, SHIREENA JOHAN WOON, Professional body/service bureau, declare the information which has been submitted herein to be true to the best of my knowledge.

**Return of Allotment of Shares**

Submit

Please fill in the following information. Fields marked \* must be completed.

<b>Resolution / Declaration</b>	<b>Share payable in cash</b>	<b>For a consideration other than cash</b>	<b>Share Capital / Allottees Particulars</b>	<b>List of Shareholders after the Allotment</b>	<b>Summary of Capital</b>
---------------------------------	------------------------------	--	--	---	---------------------------

**Authorised Capital**

	Amount	Nominal Value per Share	Currency
Authorised Capital :	<b>200000000</b>	<b>.1</b>	<b>SINGAPORE DOLLAR ( 099 )</b>

Description of discrepancy :

**Return of Allotment of Shares (Payable in cash) \***

Applicable only if share is payable in cash

Class of Shares :	Ordinary	Preference	Others
Number of shares :	<input type="text" value="7800"/>	<input type="text"/>	<input type="text"/>
Amount paid or due and payable on each share			
paid :	<input type="text" value="0.10"/>	<input type="text"/>	<input type="text"/>
due and payable :	<input type="text" value="0"/>	<input type="text"/>	<input type="text"/>
Amount of premium paid or payable on each share :	<input type="text" value="1.70"/>	<input type="text"/>	<input type="text"/>

Save

Delete Issued Share

Reset

Back

**Return of Allotment of Shares**

Submit

Please fill in the following information. Fields marked \* must be completed.

Resolution / Declaration	Share payable in cash	For a consideration other than cash	Share Capital / Allottees Particulars	List of Shareholders after the allotment	Summary of Capital
--------------------------	-----------------------	-------------------------------------	---------------------------------------	--	--------------------

**Particulars of Allottee****Please indicate whether the allottee is an Individual : \***

- Allottee is an Individual  
 Allottee is NOT an Individual

**If Allottee is an Individual :**

Shareholder Category : \*

**Individual**

Identification No. : \*

Retrieve Details

Identification Type : \*

NRIC

Name : \*

Nationality : \*

Mobile No. :

Occupation :

Email Address :

Address Type : \*

- Local  
 Foreign

Local Address (\* if Address Type is Local Address)

Postal Code :

Retrieve Address

Block/House No. :

Street Name :

Unit : #

Building/Estate Name :

Foreign Address (\* if Address Type is Foreign Address)

Address :

**If Allottee is NOT an Individual :**

Shareholder Category : \*

Company / Foreign Branch

Search

Registration No. : \*

198003912M

Retrieve Details

Name :

THE CENTRAL DEPOSITORY (PTE) LIMITED

Address Type :

Local

Local Address (\* if Address Type is Local Address)

Postal Code : 068804

Block/House No. : 2

Street Name : SHENTON WAY

Unit : # 19 - 00

Building/Estate Name : SGX CENTRE I

Foreign Address (\* if Address Type is Foreign Address)

Address :

**Details of Shares Allotted** \* Please read instructions carefully before entering.

Note : If any share or shares is/are co-owned by 2 or more persons, please assign an alphabet e.g. A to denote the Group and enter the same in the box. Enter the same alphabet in the box for every allottee in the same group. Skip this box if share(s) are owned by only one person.

Group of Share that is co-owned:  
(Share Group)

If share(s) is/are co-owned, only one allottee is to enter details in (a), (b), (c), (d) and (e). Enter "0" (zero) for subsequent allottees in box (b) and leave blank for rest of the items.

a) Nominal Value per Share :

0.10

b) No. of shares allotted :

7800

c) Class of shares allotted :

Ordinary

d) Currency :

SINGAPORE DOLLAR (099)

e) Date of allotment :

09/12/2004 (dd/mm/yyyy)

Save

Reset

Back

**Return of Allotment of Shares****Submit**

Please fill in the following information. Fields marked \* must be completed.

Resolution / Declaration	Share payable in cash	For a consideration other than cash	Share Capital / Allottees Particulars	List of Shareholders after the allotment	Summary of Capital
--------------------------	-----------------------	-------------------------------------	---------------------------------------	--	--------------------

**Share Capital (1)**

Currency :	<b>SINGAPORE DOLLAR (099)</b>		
Nominal Value per Share :	<b>0.10</b>		
Amount of Authorised Share Capital :	<b>200000000.00</b>		
Class of Shares :	Ordinary	Preference	Others
Amount of Issued Share Capital :	<b>102611742.50</b>	<b>0.00</b>	<b>0.00</b>
Amount of Paid-up Share Capital :	<b>102611742.50</b>	<b>0.00</b>	<b>0.00</b>

**RECEIPT**

Receipt No : ACR0000000972706A

Date/Time : 15/12/2004 09:38

Transaction  
No : C040553178

Agency : RCB - RCB

Application : BIZFILE PAYMENT SERVICE

Paid via : Deposit Service Account

EP Ref No :

**SINGAPORE AIRPORT TERMINAL SERVICES LIMITED****20 AIRPORT BOULEVARD****SATS INFLIGHT CATERING CENTRE 3****SINGAPORE 819659**

---

<b>Sno</b>	<b>Code/Description</b>	<b>Unit Price (S\$)</b>	<b>Qty</b>	<b>Amount</b>
1	Lodgment Of Return Of Allotment Of Share <b>COMPANY/BUSINESS NAME :</b> 197201770G / SINGAPORE AIRPORT TERMINAL SERVICES LIMITED	10.00	1	10.00
Total (S\$) :				10.00

---

**Deposit Service Account No. : 030066****Balance Amount in Deposit Account : \$ 135.00**

This is a computer-generated receipt. No signature is required.

Please print a copy of the receipt for your reference.

[HOME](#)[LOGOUT](#)



Submit

**Return of Allotment of Shares**

Please fill in the following information. Fields marked \* must be completed.

Resolution/Declaration	Shares payable in cash	For a consideration other than cash	Share Capital/Allottees Particulars	List of Shareholders after the allotment	Summary of Capital
------------------------	------------------------	-------------------------------------	-------------------------------------	--	--------------------

**Company Type**

Please click on appropriate button :

- company is listed on the securities exchange  
 company is an unlisted public company  
 company is a private company

**Power under Section 161 of the Companies Act \***

The directors have obtained the approval of the company in general meeting to issue shares.

Yes  
 No

**Resolution Made**

\* You are only required to fill in this section if the directors are not given the power under Section 161 of the Companies Act to issue shares.

Registration No. : **197201770G**Company Name : **SINGAPORE AIRPORT TERMINAL SERVICES LIMITED**Nature of Meeting : \* **Members** ▼

Place of Meeting : \*

Date of Meeting : \* (dd/mm/yyyy)

Resolution Type : \* **Special** ▼Description : \*  
(max 2000 characters)Attachment : \*  
(copy of resolution)

Browse...

**Note :**  
 Uploaded file name will be changed by suffixing time-stamp with the actual file name as **filenameyyyyMMddmmsstt**  
 Maximum File Size : 2048 KB

(Click 'Browse' to select file for attachment)

**Persons signing the resolution**

Please indicate the directors/ secretaries who signed the resolution :

 S0036442H / OW CHIN HOCK

- S0070715E / NG KEE CHOE
- S0234645A / CHEW CHOON SENG
- S1001765C / BARRY HENRY PATRICK DESKER
- S1069567H / TAN JIAK NGEЕ MICHAEL
- S1673157I / YIP WAI PING ANNABELLE
- S1852301I / HONG HAI @ HUANG HAI
- S2163476Z / CHENG WAI WING EDMUND
- S2580327B / RICHARD CHARLES HELFER

Please enter names of other corporate representatives who signed the resolution, if applicable :

**Declaration**

I, SHIREENA JOHAN WOON, Professional body/service bureau, declare the information which has been submitted herein to be true to the best of my knowledge.

Save	Reset
------	-------

**Return of Allotment of Shares**[Submit](#)

Please fill in the following information. Fields marked \* must be completed.

<b>Resolution / Declaration</b>	<b>Share payable in cash</b>	<b>For a consideration other than cash</b>	<b>Share Capital / Allottees Particulars</b>	<b>List of Shareholders after the Allotment</b>	<b>Summary of Capital</b>
---------------------------------	------------------------------	--	--	---	---------------------------

**Authorised Capital**

	<b>Amount</b>	<b>Nominal Value per Share</b>	<b>Currency</b>
Authorised Capital :	<b>200000000</b>	<b>.1</b>	<b>SINGAPORE DOLLAR ( 099 )</b>

Description of discrepancy :

**Return of Allotment of Shares (Payable in cash) \***

Applicable only if share is payable in cash

<b>Class of Shares :</b>	<b>Ordinary</b>	<b>Preference</b>	<b>Others</b>
--------------------------	-----------------	-------------------	---------------

<b>Number of shares :</b>	<input type="text" value="20800"/>	<input type="text"/>	<input type="text"/>
---------------------------	------------------------------------	----------------------	----------------------

Amount paid or due and payable on each share

paid :	<input type="text" value="0.10"/>	<input type="text"/>	<input type="text"/>
--------	-----------------------------------	----------------------	----------------------

due and payable :	<input type="text" value="0"/>	<input type="text"/>	<input type="text"/>
-------------------	--------------------------------	----------------------	----------------------

Amount of premium paid or payable on each share :

<input type="text" value="1.50"/>	<input type="text"/>	<input type="text"/>
-----------------------------------	----------------------	----------------------

[Save](#)[Delete Issued Share](#)[Reset](#)[Back](#)

**Return of Allotment of Shares**

Submit

Please fill in the following information. Fields marked \* must be completed.

Resolution / Declaration	Share payable in cash	For a consideration other than cash	Share Capital / Allottees Particulars	List of Shareholders after the allotment	Summary of Capital
-----------------------------	-----------------------	--	--	---	-----------------------

**Particulars of Allottee**

Please indicate whether the allottee is an Individual : \*

- Allottee is an Individual  
 Allottee is NOT an Individual

If Allottee is an Individual :

Shareholder Category : \*

**Individual**

Identification No. : \*

Retrieve Details

Identification Type : \*

NRIC

Name : \*

Nationality : \*

Mobile No :

Occupation :

Email Address :

Address Type : \*

- Local  
 Foreign

Local Address (\* if Address Type is Local Address)

Postal Code :

Retrieve Address

Block/House No. :

Street Name :

Unit : #

 - 

Building/Estate Name :

Foreign Address (\* if Address Type is Foreign Address)

Address :

If Allottee is NOT an Individual :

Shareholder Category : \*

Company / Foreign Branch

Search

Registration No. : \*

198003912M

Retrieve Details

Name :

THE CENTRAL DEPOSITORY (PTE) LIMITED

Address Type :

Local

Local Address (\* if Address Type is Local Address)

Postal Code : 068804

Block/House No. : 2

Street Name : SHENTON WAY

Unit : # 19 - 00

Building/Estate Name : SGX CENTRE I

Foreign Address (\* if Address Type is Foreign Address)

Address :

**Details of Shares Allotted** \* Please read instructions carefully before entering.

Note : If any share or shares is/are co-owned by 2 or more persons, please assign an alphabet e.g. A to denote the Group and enter the same in the box. Enter the same alphabet in the box for every allottee in the same group. Skip this box if share(s) are owned by only one person.

Group of Share that is co-owned:  
(Share Group)

If share(s) is/are co-owned, only one allottee is to enter details in (a), (b), (c), (d) and (e). Enter "0" (zero) for subsequent allottees in box (b) and leave blank for rest of the items.

a) Nominal Value per Share :

b) No. of shares allotted :

c) Class of shares allotted :

d) Currency :

e) Date of allotment :

 (dd/mm/yyyy)

Save

Reset

Back

**Return of Allotment of Shares**

Please fill in the following information. Fields marked \* must be completed.

Resolution / Declaration	Share payable in cash	For a consideration other than cash	Share Capital / Allottees Particulars	List of Shareholders after the allotment	Summary of Capital
--------------------------	-----------------------	-------------------------------------	---------------------------------------	--	--------------------

**Share Capital (1)**

Currency :	<b>SINGAPORE DOLLAR (099)</b>		
Nominal Value per Share :	<b>0.10</b>		
Amount of Authorised Share Capital :	<b>200000000.00</b>		
Class of Shares :	Ordinary	Preference	Others
Amount of Issued Share Capital :	<b>102610962.50</b>	<b>0.00</b>	<b>0.00</b>
Amount of Paid-up Share Capital :	<b>102610962.50</b>	<b>0.00</b>	<b>0.00</b>

GST No. :M9-0008879-T

**RECEIPT**

Receipt No : ACR0000000972419A

Date/Time : 14/12/2004 18:02

Transaction No : C040552849

Agency : RCB - RCB

Application : BIZFILE PAYMENT SERVICE

Paid via : Deposit Service Account

EP Ref No :

**SINGAPORE AIRPORT TERMINAL SERVICES LIMITED**  
**20 AIRPORT BOULEVARD**  
**SATS INFLIGHT CATERING CENTRE 3**  
**SINGAPORE 819659**

Sno	Code/Description	Unit Price (S\$)	Qty	Amount
1	Lodgment Of Return Of Allotment Of Share <b>COMPANY/BUSINESS NAME :</b> 197201770G / SINGAPORE AIRPORT TERMINAL SERVICES LIMITED	10.00	1	10.00
Total (S\$) :				10.00

**Deposit Service Account No. : 030066**  
**Balance Amount in Deposit Account : \$ 145.00**

This is a computer-generated receipt. No signature is required.

Please print a copy of the receipt for your reference.

HOME	LOGOUT
------	--------

**LOCAL COMPANY TRANSACTIONS****Return of Allotment of Shares**[Submit](#)

Please fill in the following information. Fields marked \* must be completed.

Resolution/Declaration	Shares payable in cash	For a consideration other than cash	Share Capital/Allottees Particulars	List of Shareholders after the allotment	Summary of Capital
------------------------	------------------------	-------------------------------------	-------------------------------------	--	--------------------

**Company Type**

Please click on appropriate button :

- company is listed on the securities exchange
- company is an unlisted public company
- company is a private company

**Power under Section 161 of the Companies Act \***

The directors have obtained the approval of the company in general meeting to issue shares.

Yes  
 No

**Resolution Made**

\* You are only required to fill in this section if the directors are not given the power under Section 161 of the Companies Act to issue shares.

Registration No. : **197201770G**

Company Name : **SINGAPORE AIRPORT TERMINAL SERVICES LIMITED**

Nature of Meeting : \* Place of Meeting : \* Date of Meeting : \*  (dd/mm/yyyy)Resolution Type : \* Description : \* (max 2000 characters) Attachment : \* (copy of resolution)  [Browse...](#)

**Note :**  
Uploaded file name will be changed by suffixing time-stamp with the actual file name as **filenameyyyyMMddmmsstt**  
Maximum File Size : 2048 KB

(Click 'Browse' to select file for attachment)

**Persons signing the resolution**

Please indicate the directors/ secretaries who signed the resolution :

 S0036442H / OW CHIN HOCK



- S0070715E / NG KEE CHOE
- S0234645A / CHEW CHOON SENG
- S1001765C / BARRY HENRY PATRICK DESKER
- S1069567H / TAN JIAK NGEE MICHAEL
- S1673157I / YIP WAI PING ANNABELLE
- S1852301I / HONG HAI @ HUANG HAI
- S2163476Z / CHENG WAI WING EDMUND
- S2580327B / RICHARD CHARLES HELFER

Please enter names of other corporate representatives who signed the resolution, if applicable :

**Declaration**

I, SHIREENA JOHAN WOON, Professional body/service bureau, declare the information which has been submitted herein to be true to the best of my knowledge.

Save	Reset
------	-------

**Return of Allotment of Shares**

Submit

Please fill in the following information. Fields marked \* must be completed.

<b>Resolution / Declaration</b>	<b>Share payable in cash</b>	<b>For a consideration other than cash</b>	<b>Share Capital / Allottees Particulars</b>	<b>List of Shareholders after the Allotment</b>	<b>Summary of Capital</b>
---------------------------------	------------------------------	--	--	---	---------------------------

**Authorised Capital**

	Amount	Nominal Value per Share	Currency
Authorised Capital :	<b>20000000</b>	<b>.1</b>	<b>SINGAPORE DOLLAR ( 099 )</b>

Description of discrepancy :

**Return of Allotment of Shares (Payable in cash) \***

Applicable only if share is payable in cash

Class of Shares :	Ordinary	Preference	Others
-------------------	----------	------------	--------

Number of shares :	<input type="text" value="15600"/>	<input type="text"/>	<input type="text"/>
--------------------	------------------------------------	----------------------	----------------------

Amount paid or due and payable on each share

paid :	<input type="text" value="0.10"/>	<input type="text"/>	<input type="text"/>
--------	-----------------------------------	----------------------	----------------------

due and payable :	<input type="text" value="0"/>	<input type="text"/>	<input type="text"/>
-------------------	--------------------------------	----------------------	----------------------

Amount of premium paid or payable on each share :

<input type="text" value="1.14"/>	<input type="text"/>	<input type="text"/>
-----------------------------------	----------------------	----------------------

Save

Delete Issued Share

Reset

Back

**Return of Allotment of Shares**

Submit

Please fill in the following information. Fields marked \* must be completed.

Resolution / Declaration	Share payable in cash	For a consideration other than cash	Share Capital / Allottees Particulars	List of Shareholders after the allotment	Summary of Capital
--------------------------	-----------------------	-------------------------------------	---------------------------------------	--	--------------------

**Particulars of Allottee**

Please indicate whether the allottee is an Individual : \*

- Allottee is an Individual
- Allottee is NOT an Individual

**If Allottee is an Individual :**

Shareholder Category : \*

**Individual**

Identification No. : \*

 Retrieve Details

Identification Type : \*

Name : \*

Nationality : \*

Mobile No :

Occupation :

Email Address :

Address Type : \*

- Local
- Foreign

Local Address (\* if Address Type is Local Address)

 Postal Code :  Retrieve Address

 Block/House No. : 

Street Name :

 Unit : #  - 

Building/Estate Name :

Foreign Address (\* if Address Type is Foreign Address)

 Address :   

**If Allottee is NOT an Individual :**

Shareholder Category : \*

 Search

Registration No. : \*

198003912M

Retrieve Details

Name :

THE CENTRAL DEPOSITORY (PTE) LIMITED

Address Type :

Local

Local Address (\* if Address Type is Local Address)

Postal Code : 068804

Block/House No. : 2

Street Name : SHENTON WAY

Unit : # 19 - 00

Building/Estate Name : SGX CENTRE I

Foreign Address (\* if Address Type is Foreign Address)

Address :

**Details of Shares Allotted** \* Please read instructions carefully before entering.

Note : If any share or shares is/are co-owned by 2 or more persons, please assign an alphabet e.g. A to denote the Group and enter the same in the box. Enter the same alphabet in the box for every allottee in the same group. Skip this box if share(s) are owned by only one person.

Group of Share that is co-owned:  
(Share Group)

If share(s) is/are co-owned, only one allottee is to enter details in (a), (b), (c), (d) and (e). Enter "0" (zero) for subsequent allottees in box (b) and leave blank for rest of the items.

a) Nominal Value per Share :

0.10

b) No. of shares allotted :

15600

c) Class of shares allotted :

Ordinary

d) Currency :

SINGAPORE DOLLAR (099)

e) Date of allotment :

06/12/2004 (dd/mm/yyyy)

Save

Reset

Back

**Return of Allotment of Shares**[Submit](#)

Please fill in the following information. Fields marked \* must be completed.

Resolution / Declaration	Share payable in cash	For a consideration other than cash	Share Capital / Allottees Particulars	List of Shareholders after the allotment	Summary of Capital
--------------------------	-----------------------	-------------------------------------	---------------------------------------	--	--------------------

**Share Capital (1)**

Currency :	<b>SINGAPORE DOLLAR (099)</b>		
Nominal Value per Share :	<b>0.10</b>		
Amount of Authorised Share Capital :	<b>200000000.00</b>		
Class of Shares :	Ordinary	Preference	Others
Amount of Issued Share Capital :	<b>102608882.50</b>	<b>0.00</b>	<b>0.00</b>
Amount of Paid-up Share Capital :	<b>102608882.50</b>	<b>0.00</b>	<b>0.00</b>

**RECEIPT**

Receipt No : ACR0000000972335A

Date/Time : 14/12/2004 17:32

Transaction No : C040552748

Agency : RCB - RCB

Application : BIZFILE PAYMENT SERVICE

Paid via : Deposit Service Account

EP Ref No :

**SINGAPORE AIRPORT TERMINAL SERVICES LIMITED  
20 AIRPORT BOULEVARD  
SATS INFLIGHT CATERING CENTRE 3  
SINGAPORE 819659**

Sno	Code/Description	Unit Price (S\$)	Qty	Amount
1	Lodgment Of Return Of Allotment Of Share <b>COMPANY/BUSINESS NAME :</b> 197201770G / SINGAPORE AIRPORT TERMINAL SERVICES LIMITED	10.00	1	10.00
			Total (S\$) :	10.00

**Deposit Service Account No. : 030066**  
**Balance Amount in Deposit Account : \$ 155.00**

This is a computer-generated receipt. No signature is required.

Please print a copy of the receipt for your reference.

[HOME](#)[LOGOUT](#)

**LOCAL COMPANY TRANSACTIONS**

Submit

**Return of Allotment of Shares**

Please fill in the following information. Fields marked \* must be completed.

Resolution/Declaration	Shares payable in cash	For a consideration other than cash	Share Capital/Allottees Particulars	List of Shareholders after the allotment	Summary of Capital
------------------------	------------------------	-------------------------------------	-------------------------------------	--	--------------------

**Company Type**

Please click on appropriate button :

- company is listed on the securities exchange  
 company is an unlisted public company  
 company is a private company

**Power under Section 161 of the Companies Act \***

The directors have obtained the approval of the company in general meeting to issue shares.

Yes  
 No

**Resolution Made**

\* You are only required to fill in this section if the directors are not given the power under Section 161 of the Companies Act to issue shares.

Registration No. : **197201770G**Company Name : **SINGAPORE AIRPORT TERMINAL SERVICES LIMITED**Nature of Meeting : \* **Members**

Place of Meeting : \*

Date of Meeting : \* (dd/mm/yyyy)

Resolution Type : \* **Ordinary**Description : \*  
(max 2000 characters)Attachment : \*  
(copy of resolution)

**Note :**  
 Uploaded file name will be changed by suffixing time-stamp with the actual file name as **filenameyyyyMMddmmsstt**  
 Maximum File Size : 2048 KB

Browse...

(Click 'Browse' to select file for attachment)

**Persons signing the resolution**

Please indicate the directors/ secretaries who signed the resolution :

 S0036442H / OW CHIN HOCK

- S0070715E / NG KEE CHOE
- S0234645A / CHEW CHOON SENG
- S1001765C / BARRY HENRY PATRICK DESKER
- S1069567H / TAN JIAK NGEЕ MICHAEL
- S1673157I / YIP WAI PING ANNABELLE
- S1852301I / HONG HAI @ HUANG HAI
- S2163476Z / CHENG WAI WING EDMUND
- S2580327B / RICHARD CHARLES HELFER

Please enter names of other corporate representatives who signed the resolution, if applicable :

**Declaration**

I, SHIREENA JOHAN WOON, Professional body/service bureau, declare the information which has been submitted herein to be true to the best of my knowledge.

Save	Reset
------	-------



**Return of Allotment of Shares**

Submit

Please fill in the following information. Fields marked \* must be completed.

<b>Resolution / Declaration</b>	<b>Share payable in cash</b>	<b>For a consideration other than cash</b>	<b>Share Capital / Allottees Particulars</b>	<b>List of Shareholders after the Allotment</b>	<b>Summary of Capital</b>
---------------------------------	------------------------------	--	--	---	---------------------------

**Authorised Capital**

	<b>Amount</b>	<b>Nominal Value per Share</b>	<b>Currency</b>
Authorised Capital :	<b>200000000</b>	<b>.1</b>	<b>SINGAPORE DOLLAR ( 099 )</b>

Description of discrepancy :

**Return of Allotment of Shares (Payable in cash) \***

Applicable only if share is payable in cash

<b>Class of Shares :</b>	<b>Ordinary</b>	<b>Preference</b>	<b>Others</b>
--------------------------	-----------------	-------------------	---------------

Number of shares :	<input type="text" value="15600"/>	<input type="text"/>	<input type="text"/>
--------------------	------------------------------------	----------------------	----------------------

Amount paid or due and payable on each share

paid :	<input type="text" value="0.10"/>	<input type="text"/>	<input type="text"/>
--------	-----------------------------------	----------------------	----------------------

due and payable :	<input type="text" value="0"/>	<input type="text"/>	<input type="text"/>
-------------------	--------------------------------	----------------------	----------------------

Amount of premium paid or payable on each share :

<input type="text" value="1.70"/>	<input type="text"/>	<input type="text"/>
-----------------------------------	----------------------	----------------------

Save

Delete Issued Share

Reset

Back

**Return of Allotment of Shares**

Submit

Please fill in the following information. Fields marked \* must be completed.

Resolution / Declaration	Share payable in cash	For a consideration other than cash	Share Capital / Allottees Particulars	List of Shareholders after the allotment	Summary of Capital
-----------------------------	-----------------------	--	--	---	-----------------------

**Particulars of Allottee**

Please indicate whether the allottee is an Individual : \*

- Allottee is an Individual  
 Allottee is NOT an Individual

**If Allottee is an Individual :**

Shareholder Category : \*

**Individual**

Identification No. : \*

Retrieve Details

Identification Type : \*

NRIC 

Name : \*

Nationality : \*

Mobile No. :

Occupation :

Email Address :

Address Type : \*

- Local  
 Foreign

Local Address (\* if Address Type is Local Address)

Postal Code :

Retrieve Address

Block/House No. :

Street Name :

Unit : #

 - 

Building/Estate Name :

Foreign Address (\* if Address Type is Foreign Address)

Address :

**If Allottee is NOT an Individual :**

Shareholder Category : \*

Company / Foreign Branch 

Search

Registration No. : \*

198003912M

Retrieve Details

Name :

**THE CENTRAL DEPOSITORY (PTE) LIMITED**

Address Type :

**Local**

Local Address (\* if Address Type is Local Address)

Postal Code : **068804**

Block/House No. : **2**

Street Name : **SHENTON WAY**

Unit : # **19 - 00**

Building/Estate Name : **SGX CENTRE I**

Foreign Address (\* if Address Type is Foreign Address)

Address :

**Details of Shares Allotted** \* Please read instructions carefully before entering.

Note : If any share or shares is/are co-owned by 2 or more persons, please assign an alphabet e.g. A to denote the Group and enter the same in the box. Enter the same alphabet in the box for every allottee in the same group. Skip this box if share(s) are owned by only one person.

Group of Share that is co-owned:  
(Share Group)

If share(s) is/are co-owned, only one allottee is to enter details in (a), (b), (c), (d) and (e). Enter "0" (zero) for subsequent allottees in box (b) and leave blank for rest of the items.

a) Nominal Value per Share :

0.10

b) No. of shares allotted :

15600

c) Class of shares allotted :

Ordinary

d) Currency :

SINGAPORE DOLLAR (099)

e) Date of allotment :

06/12/2004 (dd/mm/yyyy)

Save

Reset

Back

**Return of Allotment of Shares**

Submit

Please fill in the following information. Fields marked \* must be completed.

Resolution / Declaration	Share payable in cash	For a consideration other than cash	Share Capital / Allottees Particulars	List of Shareholders after the allotment	Summary of Capital
-----------------------------	-----------------------	--	--	---	-----------------------

**Share Capital (1)**

Currency :	<b>SINGAPORE DOLLAR (099)</b>		
Nominal Value per Share :	<b>0.10</b>		
Amount of Authorised Share Capital :	<b>200000000.00</b>		
Class of Shares :	Ordinary	Preference	Others
Amount of Issued Share Capital :	<b>102607322.50</b>	<b>0.00</b>	<b>0.00</b>
Amount of Paid-up Share Capital :	<b>102607322.50</b>	<b>0.00</b>	<b>0.00</b>

GST No. :M9-0008879-T

**RECEIPT**

Receipt No : ACR0000000961645A

Date/Time : 06/12/2004 10:00

Transaction No : C040541510

Agency : RCB - RCB

Application : BIZFILE PAYMENT SERVICE

Paid via : Deposit Service Account

EP Ref No :

**SINGAPORE AIRPORT TERMINAL SERVICES LIMITED  
20 AIRPORT BOULEVARD  
SATS INFLIGHT CATERING CENTRE 3  
SINGAPORE 819659**

<b>Sno Code/Description</b>	<b>Unit Price (S\$)</b>	<b>Qty</b>	<b>Amount</b>
1 Lodgment Of Return Of Allotment Of Share <b>COMPANY/BUSINESS NAME :</b> 197201770G / SINGAPORE AIRPORT TERMINAL SERVICES LIMITED	10.00	1	10.00
<b>Total (S\$) :</b>			<b>10.00</b>

**Deposit Service Account No. : 030066**  
**Balance Amount in Deposit Account : \$ 165.00**

This is a computer-generated receipt. No signature is required.

Please print a copy of the receipt for your reference.

[HOME](#)[LOGOUT](#)

**Return of Allotment of Shares**

Submit

Please fill in the following information. Fields marked \* must be completed.

Resolution/Declaration	Shares payable in cash	For a consideration other than cash	Share Capital/Allottees Particulars	List of Shareholders after the allotment	Summary of Capital
------------------------	---------------------------	---	---	---	-----------------------

**Record saved successfully.****Company Type**

Please click on appropriate button :

- company is listed on the securities exchange  
 company is an unlisted public company  
 company is a private company

**Power under Section 161 of the Companies Act \***

The directors have obtained the approval of the company in  Yes  No general meeting to issue shares.

**Resolution Made**

\* You are only required to fill in this section if the directors are not given the power under Section 161 of the Companies Act to issue shares.

Registration No. : **197201770G**Company Name : **SINGAPORE AIRPORT TERMINAL SERVICES LIMITED**

Nature of Meeting : \* Directors

Place of Meeting : \*

Date of Meeting : \* (dd/mm/yyyy)

Resolution Type : \* Director's

Description : \*  
(max 2000 characters)Attachment : \*  
(copy of resolution)**Note :**

Uploaded file name will be changed by suffixing time-stamp with the actual file name as

filenameyyyyMMddmmsstt

Browse..

(Click 'Browse' to select file for attachment)

**Persons signing the resolution**

Please indicate the directors/ secretaries who signed the resolution :

- S0036442H / OW CHIN HOCK
- S0070715E / NG KEE CHOE
- S0234645A / CHEW CHOON SENG
- S1001765C / BARRY HENRY PATRICK DESKER
- S1069567H / TAN JIAK NGEE MICHAEL
- S1673157I / YIP WAI PING ANNABELLE
- S1852301I / HONG HAI @ HUANG HAI
- S2163476Z / CHENG WAI WING EDMUND
- S2580327B / RICHARD CHARLES HELFER

Please enter names of other corporate representatives who signed the resolution, if applicable :

**Declaration**

I, LIM HONG ENG SUSANNA, Professional body/service bureau, declare the information which has been submitted herein to be true to the best of my knowledge.

**Return of Allotment of Shares**

Submit

Please fill in the following information. Fields marked \* must be completed.

Resolution / Declaration	Share payable in cash	For a consideration other than cash	Share Capital / Allottees Particulars	List of Shareholders after the Allotment	Summary of Capital
--------------------------	-----------------------	-------------------------------------	---------------------------------------	--	--------------------

**Authorised Capital**

	Amount	Nominal Value per Share	Currency
Authorised Capital :	<b>20000000</b>	<b>.1</b>	<b>SINGAPORE DOLLAR ( 099 )</b>

Description of discrepancy :

**Return of Allotment of Shares (Payable in cash) \***

Applicable only if share is payable in cash

Class of Shares :	Ordinary	Preference	Others
Number of shares :	2600		
Amount paid or due and payable on each share			
paid :	0.10		
due and payable :	0		
Amount of premium paid or payable on each share :	1.50		

Save	Delete Issued Share	Reset	Back
------	---------------------	-------	------



**Return of Allotment of Shares**

Submit

Please fill in the following information. Fields marked \* must be completed.

Resolution / Declaration	Share payable in cash	For a consideration other than cash	Share Capital / Allottees Particulars	List of Shareholders after the allotment	Summary of Capital
-----------------------------	--------------------------	---	---	---	-----------------------

**Particulars of Allottee**

Please indicate whether the allottee is an Individual : \*

- Allottee is an Individual  
 Allottee is NOT an Individual

If Allottee is an Individual :

Shareholder Category : \* **Individual**

Identification No. : \*

Retrieve Details

Identification Type : \*

NRIC 

Name : \*

Nationality : \*

Mobile No :

Occupation :

Email Address :

Address Type : \*

- Local  
 Foreign

Local Address (\* if Address Type is Local Address)

Postal Code :

Retrieve Address

Block/House No. :

Street Name :

Unit : #

 - 

Building/Estate Name :

Foreign Address (\* if Address Type is Foreign Address)

Address :

If Allottee is NOT an Individual :

Shareholder Category : \*

Company / Foreign Branch 

Search

Registration No. : \*

198003912M

Retrieve Details

Name :

**THE CENTRAL DEPOSITORY (PTE) LIMITED**

Address Type :

**Local**

Local Address (\* if Address Type is Local Address)

Postal Code : **068804**

Block/House No. : **2**

Street Name : **SHENTON WAY**

Unit : # **19 - 00**

Building/Estate Name : **SGX CENTRE I**

Foreign Address (\* if Address Type is Foreign Address)

Address :

**Details of Shares Allotted** \* Please read instructions carefully before entering.

Note : If any share or shares is/are co-owned by 2 or more persons, please assign an alphabet e.g. A to denote the Group and enter the same in the box. Enter the same alphabet in the box for every allottee in the same group. Skip this box if share(s) are owned by only one person.

Group of Share that is co-owned:  
(Share Group)

If share(s) is/are co-owned, only one allottee is to enter details in (a), (b), (c), (d) and (e). Enter "0" (zero) for subsequent allottees in box (b) and leave blank for rest of the items.

a) Nominal Value per Share :

0.10

b) No. of shares allotted :

2600

c) Class of shares allotted :

Ordinary

d) Currency :

SINGAPORE DOLLAR (099)

e) Date of allotment :

02/12/2004 (dd/mm/yyyy)

Save

Reset

Back

**Return of Allotment of Shares**

Please fill in the following information. Fields marked \* must be completed.

<b>Resolution / Declaration</b>	<b>Share payable in cash</b>	<b>For a consideration other than cash</b>	<b>Share Capital / Allottees Particulars</b>	<b>List of Shareholders after Allotment</b>	<b>Summary of Capital</b>
-------------------------------------	----------------------------------	--	--	---	-------------------------------

**List of Allottees and their particulars****Identification****No./Registration Name  
No.****Shareholder Category**

198003912M	THE CENTRAL DEPOSITORY (PTE) LIMITED	Company / Foreign Branch
------------	---	--------------------------

If No. of shareholders exceeds 50, total No. of issued shares held by the remaining shareholders are :

	<b>Ordinary</b>	<b>Preference</b>	<b>Others</b>
<b>No. of Shares</b>	<b>0</b>	<b>0</b>	<b>0</b>

**Return of Allotment of Shares**[Submit](#)

Please fill in the following information. Fields marked \* must be completed.

Resolution / Declaration	Share payable in cash	For a consideration other than cash	Share Capital / Allottees Particulars	List of Shareholders after the allotment	Summary of Capital
--------------------------	-----------------------	-------------------------------------	---------------------------------------	--	--------------------

**Share Capital (1)**

Currency :	<b>SINGAPORE DOLLAR (099)</b>		
Nominal Value per Share :	<b>0.10</b>		
Amount of Authorised Share Capital :	<b>200000000.00</b>		
Class of Shares :	Ordinary	Preference	Others
Amount of Issued Share Capital :	<b>102605762.50</b>	<b>0.00</b>	<b>0.00</b>
Amount of Paid-up Share Capital :	<b>102605762.50</b>	<b>0.00</b>	<b>0.00</b>

**RECEIPT**

Receipt No : ACR0000000961611A  
Transaction No : C040541483  
Agency : RCB - RCB  
Application : BIZFILE PAYMENT SERVICE  
Paid via : Deposit Service Account  
EP Ref No :

Date/Time : 06/12/2004 09:49

**SINGAPORE AIRPORT TERMINAL SERVICES LIMITED  
20 AIRPORT BOULEVARD  
SATS INFLIGHT CATERING CENTRE 3  
SINGAPORE 819659**

---

<b>Sno Code/Description</b>	<b>Unit Price (S\$)</b>	<b>Qty</b>	<b>Amount</b>
1 Lodgment Of Return Of Allotment Of Share <b>COMPANY/BUSINESS NAME :</b> 197201770G / SINGAPORE AIRPORT TERMINAL SERVICES LIMITED	10.00	1	10.00
<b>Total (S\$) :</b>			<b>10.00</b>

---

**Deposit Service Account No. : 030066  
Balance Amount in Deposit Account : \$ 175.00**

This is a computer-generated receipt. No signature is required.

Please print a copy of the receipt for your reference.

[HOME](#)[LOGOUT](#)

**Return of Allotment of Shares**

Submit

Please fill in the following information. Fields marked \* must be completed.

Resolution/Declaration	Shares payable in cash	For a consideration other than cash	Share Capital/Allottees Particulars	List of Shareholders after the allotment	Summary of Capital
------------------------	------------------------	-------------------------------------	-------------------------------------	--	--------------------

Record saved successfully.

**Company Type**

Please click on appropriate button :

- company is listed on the securities exchange
- company is an unlisted public company
- company is a private company

**Power under Section 161 of the Companies Act \***

The directors have obtained the approval of the company in  Yes  No general meeting to issue shares.

**Resolution Made**

\* You are only required to fill in this section if the directors are not given the power under Section 161 of the Companies Act to issue shares.

Registration No. : **197201770G**Company Name : **SINGAPORE AIRPORT TERMINAL SERVICES LIMITED**

Nature of Meeting : \* Directors

Place of Meeting : \*

Date of Meeting : \* (dd/mm/yyyy)

Resolution Type : \* Director's

Description : \*  
(max 2000 characters)Attachment : \*  
(copy of resolution)

**Note :**  
Uploaded file name will be changed by suffixing time-stamp with the actual file name as  
**filenameyyyyMMddmmsstt**

Browse..

(Click 'Browse' to select file for attachment)

**Persons signing the resolution**

Please indicate the directors/ secretaries who signed the resolution :

- S0036442H / OW CHIN HOCK
- S0070715E / NG KEE CHOE
- S0234645A / CHEW CHOON SENG
- S1001765C / BARRY HENRY PATRICK DESKER
- S1069567H / TAN JIAK NGEE MICHAEL
- S1673157I / YIP WAI PING ANNABELLE
- S1852301I / HONG HAI @ HUANG HAI
- S2163476Z / CHENG WAI WING EDMUND
- S2580327B / RICHARD CHARLES HELFER

Please enter names of other corporate representatives who signed the resolution, if applicable :

**Declaration**

I, LIM HONG ENG SUSANNA, Professional body/service bureau, declare the information which has been submitted herein to be true to the best of my knowledge.

**Return of Allotment of Shares**[Submit](#)

Please fill in the following information. Fields marked \* must be completed.

<b>Resolution / Declaration</b>	<b>Share payable in cash</b>	<b>For a consideration other than cash</b>	<b>Share Capital / Allottees Particulars</b>	<b>List of Shareholders after the Allotment</b>	<b>Summary of Capital</b>
-------------------------------------	----------------------------------	--	--	---	-------------------------------

**Authorised Capital**

	<b>Amount</b>	<b>Nominal Value per Share</b>	<b>Currency</b>
Authorised Capital :	<b>200000000</b>	<b>.1</b>	<b>SINGAPORE DOLLAR ( 099 )</b>

Description of discrepancy :

**Return of Allotment of Shares (Payable in cash) \***

Applicable only if share is payable in cash

<b>Class of Shares :</b>	<b>Ordinary</b>	<b>Preference</b>	<b>Others</b>
Number of shares :	<input type="text" value="2600"/>	<input type="text"/>	<input type="text"/>
Amount paid or due and payable on each share			
paid :	<input type="text" value="0.10"/>	<input type="text"/>	<input type="text"/>
due and payable :	<input type="text" value="0"/>	<input type="text"/>	<input type="text"/>
Amount of premium paid or payable on each share :	<input type="text" value="1.14"/>	<input type="text"/>	<input type="text"/>

[Save](#) [Delete Issued Share](#) [Reset](#) [Back](#)



**Return of Allotment of Shares**

Submit

Please fill in the following information. Fields marked \* must be completed.

Resolution / Declaration	Share payable in cash	For a consideration other than cash	Share Capital / Allottees Particulars	List of Shareholders after the allotment	Summary of Capital
--------------------------	-----------------------	-------------------------------------	---------------------------------------	--	--------------------

**Particulars of Allottee**

Please indicate whether the allottee is an Individual : \*

- Allottee is an Individual  
 Allottee is NOT an Individual

If Allottee is an Individual :

Shareholder Category : \* **Individual**

Identification No. : \*

Retrieve Details

Identification Type : \*

NRIC 

Name : \*

Nationality : \*

Mobile No :

Occupation :

Email Address :

Address Type : \*

- Local  
 Foreign

Local Address (\* if Address Type is Local Address)

Postal Code :

Retrieve Address

Block/House No. :

Street Name :

Unit : #

 - 

Building/Estate Name :

Foreign Address (\* if Address Type is Foreign Address)

Address :

If Allottee is NOT an Individual :

Shareholder Category : \*

Company / Foreign Branch 

Search

Registration No. : \*

198003912M

Retrieve Details

Name : **THE CENTRAL DEPOSITORY (PTE) LIMITED**

Address Type : **Local**

Local Address (\* if Address Type is Local Address)

Postal Code : **068804**

Block/House No. : **2**

Street Name : **SHENTON WAY**

Unit : # **19 - 00**

Building/Estate Name : **SGX CENTRE I**

Foreign Address (\* if Address Type is Foreign Address)

Address :

**Details of Shares Allotted** \* Please read instructions carefully before entering.

Note : If any share or shares is/are co-owned by 2 or more persons, please assign an alphabet e.g. A to denote the Group and enter the same in the box. Enter the same alphabet in the box for every allottee in the same group. Skip this box if share(s) are owned by only one person.

Group of Share that is co-owned:  
(Share Group)

If share(s) is/are co-owned, only one allottee is to enter details in (a), (b), (c), (d) and (e). Enter "0" (zero) for subsequent allottees in box (b) and leave blank for rest of the items.

a) Nominal Value per Share :

b) No. of shares allotted :

c) Class of shares allotted :

d) Currency :

e) Date of allotment :  (dd/mm/yyyy)

**Return of Allotment of Shares**[Submit](#)

Please fill in the following information. Fields marked \* must be completed.

<b>Resolution / Declaration</b>	<b>Share payable in cash</b>	<b>For a consideration other than cash</b>	<b>Share Capital / Allottees Particulars</b>	<b>List of Shareholders after Allotment</b>	<b>Summary of Capital</b>
-------------------------------------	----------------------------------	--	--	---	-------------------------------

**List of Allottees and their particulars****Identification****No./Registration Name  
No.****Shareholder Category**

198003912M	THE CENTRAL DEPOSITORY (PTE) LIMITED	Company / Foreign Branch
------------	---	--------------------------

If No. of shareholders exceeds 50, total No. of issued shares held by the remaining shareholders are :

<b>No. of Shares</b>	<b>Ordinary</b>	<b>Preference</b>	<b>Others</b>
	0	0	0

**Return of Allotment of Shares****Submit**

Please fill in the following information. Fields marked \* must be completed.

Resolution / Declaration	Share payable in cash	For a consideration other than cash	Share Capital / Allottees Particulars	List of Shareholders after the allotment	Summary of Capital
--------------------------	-----------------------	-------------------------------------	---------------------------------------	--	--------------------

**Share Capital (1)**

Currency :	<b>SINGAPORE DOLLAR (099)</b>		
Nominal Value perShare :	<b>0.10</b>		
Amount of Authorised Share Capital :	<b>200000000.00</b>		
Class of Shares :	Ordinary	Preference	Others
Amount of Issued Share Capital :	<b>102605502.50</b>	<b>0.00</b>	<b>0.00</b>
Amount of Paid-up Share Capital :	<b>102605502.50</b>	<b>0.00</b>	<b>0.00</b>

**RECEIPT**

Receipt No : ACR0000000956506A

Date/Time : 01/12/2004 10:46

Transaction  
No : C040536054

Agency : RCB - RCB

Application : BIZFILE PAYMENT SERVICE

Paid via : Deposit Service Account

EP Ref No :

**SINGAPORE AIRPORT TERMINAL SERVICES LIMITED**  
**20 AIRPORT BOULEVARD**  
**SATS INFLIGHT CATERING CENTRE 3**  
**SINGAPORE 819659**

<b>Sno</b>	<b>Code/Description</b>	<b>Unit Price (S\$)</b>	<b>Qty</b>	<b>Amount</b>
1	Lodgment Of Return Of Allotment Of Share <b>COMPANY/BUSINESS NAME :</b> 197201770G / SINGAPORE AIRPORT TERMINAL SERVICES LIMITED	10.00	1	10.00
			<b>Total (S\$) :</b>	<b>10.00</b>

**Deposit Service Account No. : 030066**  
**Balance Amount in Deposit Account : \$ 185.00**

This is a computer-generated receipt. No signature is required.

Please print a copy of the receipt for your reference.

[HOME](#)[LOGOUT](#)

**LOCAL COMPANY TRANSACTIONS**

[HOME](#)   [LOGOUT](#)

**Return of Allotment of Shares**

[Submit](#)

Please fill in the following information. Fields marked \* must be completed.

Resolution/Declaration	Shares payable in cash	For a consideration other than cash	Share Capital/Allottees Particulars	List of Shareholders after the allotment	Summary of Capital
------------------------	------------------------	-------------------------------------	-------------------------------------	--	--------------------

**Record saved successfully.**

**Company Type**

Please click on appropriate button :

- company is listed on the securities exchange
- company is an unlisted public company
- company is a private company

**Power under Section 161 of the Companies Act \***

The directors have obtained the approval of the company in  
 general meeting to issue shares.

Yes  
 No

**Resolution Made**

\* You are only required to fill in this section if the directors are not given the power under Section 161 of the Companies Act to issue shares.

Registration No. : **197201770G**

Company Name : **SINGAPORE AIRPORT TERMINAL SERVICES LIMITED**

Nature of Meeting : \*

Place of Meeting : \*

Date of Meeting: \*  (dd/mm/yyyy)

Resolution Type : \*

Description : \*  
(max 2000 characters)

Attachment : \*  
(copy of resolution)

**Note :**  
Uploaded file name will be changed by suffixing time-stamp with the actual file name as  
 [Browse...](#)

(Click 'Browse' to select file for attachment)

filenameyyyyMMddmmsstt

**Persons signing the resolution**

Please indicate the directors/ secretaries who signed the resolution :

- S0036442H / OW CHIN HOCK
- S0070715E / NG KEE CHOE
- S0234645A / CHEW CHOON SENG
- S1001765C / BARRY HENRY PATRICK DESKER
- S1069567H / TAN JIAK NGEE MICHAEL
- S1673157I / YIP WAI PING ANNABELLE
- S1852301I / HONG HAI @ HUANG HAI
- S2163476Z / CHENG WAI WING EDMUND
- S2580327B / RICHARD CHARLES HELFER

Please enter names of other corporate representatives who signed the resolution, if applicable :

**Declaration**

I, LIM HONG ENG SUSANNA, Professional body/service bureau, declare the information which has been submitted herein to be true to the best of my knowledge.

---

**Return of Allotment of Shares****Submit**

Please fill in the following information. Fields marked \* must be completed.

<u>Resolution / Declaration</u>	Share payable in cash	For a consideration other than cash	Share Capital / Allottees Particulars	List of Shareholders after the Allotment	Summary of Capital
-------------------------------------	--------------------------	---	---	---	-----------------------

**Authorised Capital**

	Amount	Nominal Value per Share	Currency
Authorised Capital :	<b>200000000</b>	<b>.1</b>	<b>SINGAPORE DOLLAR ( 099 )</b>

Description of discrepancy :

**Return of Allotment of Shares (Payable in cash) \***

Applicable only if share is payable in cash

Class of Shares :	Ordinary	Preference	Others
Number of shares :	<input type="text" value="2600"/>	<input type="text"/>	<input type="text"/>
Amount paid or due and payable on each share	<hr/>		
paid :	<input type="text" value="0.10"/>	<input type="text"/>	<input type="text"/>
due and payable :	<input type="text" value="0"/>	<input type="text"/>	<input type="text"/>
Amount of premium paid or payable on each share :	<input type="text" value="1.50"/>	<input type="text"/>	<input type="text"/>

**Save****Delete Issued Share****Reset****Back**



**Return of Allotment of Shares****Submit**

Please fill in the following information. Fields marked \* must be completed.

<b>Resolution / Declaration</b>	<b>Share payable in cash</b>	<b>For a consideration other than cash</b>	<b>Share Capital / Allottees Particulars</b>	<b>List of Shareholders after the allotment</b>	<b>Summary of Capital</b>
-------------------------------------	----------------------------------	--	--	---	-------------------------------

**Particulars of Allottee****Please indicate whether the allottee is an Individual : \***

- Allottee is an Individual  
 Allottee is NOT an Individual

**If Allottee is an Individual :**Shareholder Category : \* **Individual**

Identification No. : \*

**Retrieve Details**

Identification Type : \*

NRIC

Name : \*

Nationality : \*

Mobile No :

Occupation :

Email Address :

Address Type : \*

- Local  
 Foreign

Local Address (\* if Address Type is Local Address)

Postal Code :

**Retrieve Address**

Block/House No. :

Street Name :

Unit : #

 - 

Building/Estate Name :

Foreign Address (\* if Address Type is Foreign Address)

Address :

**If Allottee is NOT an Individual :**

Shareholder Category : \*

Company / Foreign Branch

**Search**

Registration No. : \*

198003912M

Retrieve Details

Name : **THE CENTRAL DEPOSITORY (PTE) LIMITED**

Address Type : **Local**

Local Address (\* if Address Type is Local Address)

Postal Code : **068804**

Block/House No. : **2**

Street Name : **SHENTON WAY**

Unit : # **19 - 00**

Building/Estate Name : **SGX CENTRE I**

Foreign Address (\* if Address Type is Foreign Address)

Address :

**Details of Shares Allotted** \* Please read instructions carefully before entering.

Note : If any share or shares is/are co-owned by 2 or more persons, please assign an alphabet e.g. A to denote the Group and enter the same in the box. Enter the same alphabet in the box for every allottee in the same group. Skip this box if share(s) are owned by only one person.

Group of Share that is co-owned:  
(Share Group)

If share(s) is/are co-owned, only one allottee is to enter details in (a), (b), (c), (d) and (e). Enter "0" (zero) for subsequent allottees in box (b) and leave blank for rest of the items.

a) Nominal Value per Share :

b) No. of shares allotted :

c) Class of shares allotted :

d) Currency :

e) Date of allotment :  (dd/mm/yyyy)

**Return of Allotment of Shares****Submit**

Please fill in the following information. Fields marked \* must be completed.

<b>Resolution / Declaration</b>	<b>Share payable in cash</b>	<b>For a consideration other than cash</b>	<b>Share Capital / Allottees Particulars</b>	<b>List of Shareholders after Allotment</b>	<b>Summary of Capital</b>
-------------------------------------	----------------------------------	--	--	---	-------------------------------

**List of Allottees and their particulars****Identification****No./Registration Name  
No.****Shareholder Category**

198003912M	THE CENTRAL DEPOSITORY (PTE) LIMITED	Company / Foreign Branch
------------	---	--------------------------

If No. of shareholders exceeds 50, total No. of issued shares held by the remaining shareholders are :

<b>No. of Shares</b>	<b>Ordinary</b>	<b>Preference</b>	<b>Others</b>
	0	0	0

**Return of Allotment of Shares****Submit**

Please fill in the following information. Fields marked \* must be completed.

<u>Resolution / Declaration</u>	<u>Share payable in cash</u>	<u>For a consideration other than cash</u>	<u>Share Capital / Allottees Particulars</u>	<u>List of Shareholders after the allotment</u>	<u>Summary of Capital</u>
<b>Share Capital (1)</b>					
Currency :	<b>SINGAPORE DOLLAR (099)</b>				
Nominal Value per Share :	<b>0.10</b>				
Amount of Authorised Share Capital :	<b>200000000.00</b>				
Class of Shares :	Ordinary	Preference	Others		
Amount of Issued Share Capital :	<b>102605242.50</b>	<b>0.00</b>	<b>0.00</b>		
Amount of Paid-up Share Capital :	<b>102605242.50</b>	<b>0.00</b>	<b>0.00</b>		

**RECEIPT**

Receipt No : ACR0000000956484A

Date/Time : 01/12/2004 10:41

Transaction No : C040536033

Agency : RCB - RCB

Application : BIZFILE PAYMENT SERVICE

Paid via : Deposit Service Account

EP Ref No :

**SINGAPORE AIRPORT TERMINAL SERVICES LIMITED  
20 AIRPORT BOULEVARD  
SATS INFLIGHT CATERING CENTRE 3  
SINGAPORE 819659**

<b>Sno Code/Description</b>	<b>Unit Price (S\$)</b>	<b>Qty</b>	<b>Amount</b>
1 Lodgment Of Return Of Allotment Of Share <b>COMPANY/BUSINESS NAME :</b> 197201770G / SINGAPORE AIRPORT TERMINAL SERVICES LIMITED	10.00	1	10.00
<b>Total (S\$) :</b>			<b>10.00</b>

**Deposit Service Account No. : 030066**  
**Balance Amount in Deposit Account : \$ 195.00**

This is a computer-generated receipt. No signature is required.

Please print a copy of the receipt for your reference.

[HOME](#)[LOGOUT](#)

**Return of Allotment of Shares****Submit**

Please fill in the following information. Fields marked \* must be completed.

Resolution/Declaration	Shares payable in cash	For a consideration other than cash	Share Capital/Allottees Particulars	List of Shareholders after the allotment	Summary of Capital
------------------------	---------------------------	---	---	---	-----------------------

**Record saved successfully.****Company Type**

Please click on appropriate button :

- company is listed on the securities exchange  
 company is an unlisted public company  
 company is a private company

**Power under Section 161 of the Companies Act \***

The directors have obtained the approval of the company in  Yes  
 general meeting to issue  No shares.

**Resolution Made**

\* You are only required to fill in this section if the directors are not given the power under Section 161 of the Companies Act to issue shares.

Registration No. : **197201770G**Company Name : **SINGAPORE AIRPORT TERMINAL SERVICES LIMITED**Nature of Meeting : \* 

Place of Meeting : \*

Date of Meeting: \*  (dd/mm/yyyy)Resolution Type : \* Description : \*  
(max 2000 characters)
Attachment : \*  
(copy of resolution)**Note :**

Uploaded file name will be changed by suffixing time-stamp with the actual file name as

**filenameyyyyMMddmmsstt**
 **Browse...**

(Click 'Browse' to select file for attachment)

**Persons signing the resolution**

Please indicate the directors/ secretaries who signed the resolution :

- S0036442H / OW CHIN HOCK
- S0070715E / NG KEE CHOE
- S0234645A / CHEW CHOON SENG
- S1001765C / BARRY HENRY PATRICK DESKER
- S1069567H / TAN JIAK NGEE MICHAEL
- S1673157I / YIP WAI PING ANNABELLE
- S1852301I / HONG HAI @ HUANG HAI
- S2163476Z / CHENG WAI WING EDMUND
- S2580327B / RICHARD CHARLES HELFER

Please enter names of other corporate representatives who signed the resolution, if applicable :

**Declaration**

I, LIM HONG ENG SUSANNA, Professional body/service bureau, declare the information which has been submitted herein to be true to the best of my knowledge.

**Return of Allotment of Shares**

[Submit](#)

Please fill in the following information. Fields marked \* must be completed.

<u>Resolution / Declaration</u>	<u>Share payable in cash</u>	<u>For a consideration other than cash</u>	<u>Share Capital / Allottees Particulars</u>	<u>List of Shareholders after the Allotment</u>	<u>Summary of Capital</u>
---------------------------------	------------------------------	--	--	---	---------------------------

**Authorised Capital**

	<u>Amount</u>	<u>Nominal Value per Share</u>	<u>Currency</u>
Authorised Capital :	<b>20000000</b>	<b>.1</b>	<b>SINGAPORE DOLLAR ( 099 )</b>

Description of discrepancy :

**Return of Allotment of Shares (Payable in cash) \***

Applicable only if share is payable in cash

<u>Class of Shares :</u>	<u>Ordinary</u>	<u>Preference</u>	<u>Others</u>
Number of shares :	<input type="text" value="7800"/>	<input type="text"/>	<input type="text"/>
Amount paid or due and payable on each share			
paid :	<input type="text" value="0.10"/>	<input type="text"/>	<input type="text"/>
due and payable :	<input type="text" value="0"/>	<input type="text"/>	<input type="text"/>
Amount of premium paid or payable on each share :	<input type="text" value="1.14"/>	<input type="text"/>	<input type="text"/>

[Save](#)   [Delete Issued Share](#)   [Reset](#)   [Back](#)



**Return of Allotment of Shares****Submit**

Please fill in the following information. Fields marked \* must be completed.

<u>Resolution / Declaration</u>	<u>Share payable in cash</u>	<u>For a consideration other than cash</u>	<u>Share Capital / Allottees Particulars</u>	<u>List of Shareholders after the allotment</u>	<u>Summary of Capital</u>
---------------------------------	------------------------------	--	--	---	---------------------------

**Particulars of Allottee****Please indicate whether the allottee is an Individual : \***

- Allottee is an Individual  
 Allottee is NOT an Individual

**If Allottee is an Individual :**Shareholder Category : \* **Individual**

Identification No. : \*

**Retrieve Details**

Identification Type : \*

NRIC 

Name : \*

Nationality : \*

Mobile No :

Occupation :

Email Address :

Address Type : \*

- Local  
 Foreign

Local Address (\* if Address Type is Local Address)

Postal Code :

**Retrieve Address**

Block/House No. :

Street Name :

Unit : #

 - 

Building/Estate Name :

Foreign Address (\* if Address Type is Foreign Address)

Address :

**If Allottee is NOT an Individual :**

Shareholder Category : \*

Company / Foreign Branch **Search**

Registration No. : \*

198003912M

Retrieve Details

Name :

**THE CENTRAL DEPOSITORY (PTE) LIMITED**

Address Type :

**Local**

Local Address (\* if Address Type is Local Address)

Postal Code : **068804**

Block/House No. : **2**

Street Name : **SHENTON WAY**

Unit : # **19 - 00**

Building/Estate Name : **SGX CENTRE I**

Foreign Address (\* if Address Type is Foreign Address)

Address :

**Details of Shares Allotted** \* Please read instructions carefully before entering.

Note : If any share or shares is/are co-owned by 2 or more persons, please assign an alphabet e.g. A to denote the Group and enter the same in the box. Enter the same alphabet in the box for every allottee in the same group. Skip this box if share(s) are owned by only one person.

Group of Share that is co-owned:  
(Share Group)

If share(s) is/are co-owned, only one allottee is to enter details in (a), (b), (c), (d) and (e). Enter "0" (zero) for subsequent-allottees-in-box-(b) and leave blank for rest of the items.

a) Nominal Value per Share :

0.10

b) No. of shares allotted :

7800

c) Class of shares allotted :

Ordinary

d) Currency :

SINGAPORE DOLLAR (099)

e) Date of allotment :

29/11/2004 (dd/mm/yyyy)

Save

Reset

Back

**Return of Allotment of Shares****Submit**

Please fill in the following information. Fields marked \* must be completed.

<b>Resolution / Declaration</b>	<b>Share payable in cash</b>	<b>For a consideration other than cash</b>	<b>Share Capital / Allottees Particulars</b>	<b>List of Shareholders after Allotment</b>	<b>Summary of Capital</b>
-------------------------------------	----------------------------------	--	--	---	-------------------------------

**List of Allottees and their particulars****Identification****No./Registration Name  
No.****Shareholder Category**

198003912M	THE CENTRAL DEPOSITORY (PTE) LIMITED	Company / Foreign Branch
------------	---	--------------------------

If No. of shareholders exceeds 50, total No. of issued shares held by the remaining shareholders are :

<b>No. of Shares</b>	<b>Ordinary</b>	<b>Preference</b>	<b>Others</b>
	0	0	0

**Return of Allotment of Shares****Submit**

Please fill in the following information. Fields marked \* must be completed.

<u>Resolution / Declaration</u>	<u>Share payable in cash</u>	<u>For a consideration other than cash</u>	<u>Share Capital / Allottees Particulars</u>	<u>List of Shareholders after the allotment</u>	<u>Summary of Capital</u>
<b>Share Capital (1)</b>					
Currency :	<b>SINGAPORE DOLLAR (099)</b>				
Nominal Value per Share :	<b>0.10</b>				
Amount of Authorised Share Capital :	<b>200000000.00</b>				
Class of Shares :	Ordinary	Preference	Others		
Amount of Issued Share Capital :	<b>102604982.50</b>	<b>0.00</b>	<b>0.00</b>		
Amount of Paid-up Share Capital :	<b>102604982.50</b>	<b>0.00</b>	<b>0.00</b>		

**INFORMATION RESOURCES****Receipt Enquiry**

This is a comprehensive listing of receipts available for all transactions.

Receipt No. : ACR0000000956465A  
Date and Time : 01/12/2004 10:31:20  
EP Ref. No. :  
Payment Mode : DEPOSIT SERVICE ACCOUNT  
Deposit Service Account No : 030066  
Status of Receipt : Processed

**Payment Details**

<b>S/No</b>	<b>Payment Description</b>	<b>Transaction No.</b>	<b>Amount</b>	<b>GST</b>
1	RETURN OF ALLOTMENT OF SHARES Regn No : 197201770G Name :SINGAPORE AIRPORT TERMINAL SERVICES LIMITED	C040536014	10.00	0.00
<b>Total</b>			<b>10.00</b>	<b>0.00</b>

[Back](#)

**Return of Allotment of Shares**

Submit

Please fill in the following information. Fields marked \* must be completed.

Resolution/Declaration	Shares payable in cash	For a consideration other than cash	Share Capital/Allottees Particulars	List of Shareholders after the allotment	Summary of Capital
------------------------	------------------------	-------------------------------------	-------------------------------------	--	--------------------

Record saved successfully.

**Company Type**

Please click on appropriate button :

- company is listed on the securities exchange
- company is an unlisted public company
- company is a private company

**Power under Section 161 of the Companies Act \***

The directors have obtained the approval of the company in  Yes  No general meeting to issue shares.

**Resolution Made**

\* You are only required to fill in this section if the directors are not given the power under Section 161 of the Companies Act to issue shares.

Registration No. : **197201770G**Company Name : **SINGAPORE AIRPORT TERMINAL SERVICES LIMITED**

Nature of Meeting : \* Directors

Place of Meeting : \*

Date of Meeting : \* (dd/mm/yyyy)

Resolution Type : \* Director's

Description : \* (max 2000 characters)

Attachment : \* (copy of resolution)

**Note :**

Uploaded file name will be changed by suffixing time-stamp with the actual file name as

filenameyyyyMMddmmsstt

Browse...

(Click 'Browse' to select file for attachment)

**Persons signing the resolution**

Please indicate the directors/ secretaries who signed the resolution :

- S0036442H / OW CHIN HOCK
- S0070715E / NG KEE CHOE
- S0234645A / CHEW CHOON SENG
- S1001765C / BARRY HENRY PATRICK DESKER
- S1069567H / TAN JIAK NGEE MICHAEL
- S1673157I / YIP WAI PING ANNABELLE
- S1852301I / HONG HAI @ HUANG HAI
- S2163476Z / CHENG WAI WING EDMUND
- S2580327B / RICHARD CHARLES HELFER

Please enter names of other corporate representatives who signed the resolution, if applicable :

**Declaration**

I, LIM HONG ENG SUSANNA, Professional body/service bureau, declare the information which has been submitted herein to be true to the best of my knowledge.

**Return of Allotment of Shares****Submit**

Please fill in the following information. Fields marked \* must be completed.

<u>Resolution / Declaration</u>	<u>Share payable in cash</u>	<u>For a consideration other than cash</u>	<u>Share Capital / Allotees Particulars</u>	<u>List of Shareholders after the Allotment</u>	<u>Summary of Capital</u>
---------------------------------	------------------------------	--	---	---	---------------------------

**Authorised Capital**

	<u>Amount</u>	<u>Nominal Value per Share</u>	<u>Currency</u>
Authorised Capital :	<b>200000000</b>	<b>.1</b>	<b>SINGAPORE DOLLAR ( 099 )</b>

Description of discrepancy :

**Return of Allotment of Shares (Payable in cash) \***

Applicable only if share is payable in cash

<u>Class of Shares :</u>	<u>Ordinary</u>	<u>Preference</u>	<u>Others</u>
Number of shares :	<input type="text" value="2600"/>	<input type="text"/>	<input type="text"/>

Amount paid or due and payable on each share

paid :	<input type="text" value="0.10"/>	<input type="text"/>	<input type="text"/>
due and payable :	<input type="text" value="0"/>	<input type="text"/>	<input type="text"/>
Amount of premium paid or payable on each share :	<input type="text" value="1.70"/>	<input type="text"/>	<input type="text"/>



**Return of Allotment of Shares****Submit**

Please fill in the following information. Fields marked \* must be completed.

<u>Resolution / Declaration</u>	<u>Share payable in cash</u>	<u>For a consideration other than cash</u>	<u>Share Capital / Allottees Particulars</u>	<u>List of Shareholders after the allotment</u>	<u>Summary of Capital</u>
-------------------------------------	----------------------------------	--	--	---	-------------------------------

**Particulars of Allottee****Please indicate whether the allottee is an Individual : \***

- Allottee is an Individual  
 Allottee is NOT an Individual

**If Allottee is an Individual :**Shareholder Category : \* **Individual**Identification No. : \*  **Retrieve Details**Identification Type : \* Name : \* Nationality : \* Mobile No : Occupation : Email Address : Address Type : \*  
 Local  
 Foreign

Local Address (\* if Address Type is Local Address)

Postal Code :  **Retrieve Address**Block/House No. : 

Street Name :

Unit : #  - 

Building/Estate Name :

Foreign Address (\* if Address Type is Foreign Address)

Address :   
**If Allottee is NOT an Individual :**Shareholder Category : \*  **Search**

Registration No. : \* 198003912M Retrieve Details  
Name : THE CENTRAL DEPOSITORY (PTE) LIMITED

Address Type : Local

Local Address (\* if Address Type is Local Address)

Postal Code : 068804

Block/House No. : 2

Street Name : SHENTON WAY

Unit : # 19 - 00

Building/Estate Name : SGX CENTRE I

Foreign Address (\* if Address Type is Foreign Address)

Address :

**Details of Shares Allotted** \* Please read instructions carefully before entering.

Note : If any share or shares is/are co-owned by 2 or more persons, please assign an alphabet e.g. A to denote the Group and enter the same in the box. Enter the same alphabet in the box for every allottee in the same group. Skip this box if share(s) are owned by only one person.

Group of Share that is co-owned:  
(Share Group)

If share(s) is/are co-owned, only one allottee is to enter details in (a), (b), (c), (d) and (e). Enter "0" (zero) for subsequent allottees in box (b) and leave blank for rest of the items.

- a) Nominal Value per Share :
- b) No. of shares allotted :
- c) Class of shares allotted :
- d) Currency :
- e) Date of allotment :  (dd/mm/yyyy)

**Return of Allotment of Shares****Submit**

Please fill in the following information. Fields marked \* must be completed.

<b>Resolution / Declaration</b>	<b>Share payable in cash</b>	<b>For a consideration other than cash</b>	<b>Share Capital / Allottees Particulars</b>	<b>List of Shareholders after Allotment</b>	<b>Summary of Capital</b>
-------------------------------------	----------------------------------	--	--	---	-------------------------------

**List of Allottees and their particulars****Identification****No./Registration Name  
No.****Shareholder Category**

198003912M	THE CENTRAL DEPOSITORY (PTE) LIMITED	Company / Foreign Branch
------------	---	--------------------------

If No. of shareholders exceeds 50, total No. of issued shares held by the remaining shareholders are :

<b>No. of Shares</b>	<b>Ordinary</b>	<b>Preference</b>	<b>Others</b>
	0	0	0

**Return of Allotment of Shares****Submit**

Please fill in the following information. Fields marked \* must be completed.

<u>Resolution / Declaration</u>	<u>Share payable in cash</u>	<u>For a consideration other than cash</u>	<u>Share Capital / Allottees Particulars</u>	<u>List of Shareholders after the allotment</u>	<u>Summary of Capital</u>
---------------------------------	------------------------------	--	--	---	---------------------------

**Share Capital (1)**

Currency :	<b>SINGAPORE DOLLAR (099)</b>		
Nominal Value per Share :	<b>0.10</b>		
Amount of Authorised Share Capital :	<b>200000000.00</b>		
Class of Shares :	Ordinary	Preference	Others
Amount of Issued Share Capital :	<b>102604202.50</b>	<b>0.00</b>	<b>0.00</b>
Amount of Paid-up Share Capital :	<b>102604202.50</b>	<b>0.00</b>	<b>0.00</b>

GST No. :M9-0008879-T

**RECEIPT**

Receipt No : ACR0000000954300A

Date/Time : 30/11/2004 10:19

Transaction  
No : C040533578

Agency : RCB - RCB

Application : BIZFILE PAYMENT SERVICE

Paid via : Deposit Service Account

EP Ref No :

**SINGAPORE AIRPORT TERMINAL SERVICES LIMITED**  
**20 AIRPORT BOULEVARD**  
**SATS INFLIGHT CATERING CENTRE 3**  
**SINGAPORE 819659**

<b>Sno Code/Description</b>	<b>Unit Price (S\$)</b>	<b>Qty</b>	<b>Amount</b>
1 Lodgment Of Return Of Allotment Of Share <b>COMPANY/BUSINESS NAME :</b> 197201770G / SINGAPORE AIRPORT TERMINAL SERVICES LIMITED	10.00	1	10.00
<b>Total (S\$) :</b>			<b>10.00</b>

**Deposit Service Account No. : 030066**  
**Balance Amount in Deposit Account : \$ 215.00**

This is a computer-generated receipt. No signature is required.

Please print a copy of the receipt for your reference.

[HOME](#)[LOGOUT](#)

**Return of Allotment of Shares****Submit**

Please fill in the following information. Fields marked \* must be completed.

Resolution/Declaration	Shares payable in cash	For a consideration other than cash	Share Capital/Allottees Particulars	List of Shareholders after the allotment	Summary of Capital
------------------------	---------------------------	---	---	---	-----------------------

**Record saved successfully.****Company Type**

Please click on appropriate button :

- company is listed on the securities exchange  
 company is an unlisted public company  
 company is a private company

**Power under Section 161 of the Companies Act \***

The directors have obtained  
the approval of the company in  Yes  
general meeting to issue  No  
shares.

**Resolution Made**

\* You are only required to fill in this section if the directors are not given the power under Section 161 of the Companies Act to issue shares.

Registration No. : **197201770G**Company Name : **SINGAPORE AIRPORT TERMINAL SERVICES LIMITED**Nature of Meeting : \* Directors 

Place of Meeting : \*

Date of Meeting : \*  (dd/mm/yyyy)Resolution Type : \* Director's Description : \*  
(max 2000 characters)
Attachment : \*  
(copy of resolution)**Note :**

Uploaded file name will be  
changed by suffixing time-  
stamp with the actual file  
name as

**filenameyyyyMMddmmsstt****Browse...**

(Click 'Browse' to select file for attachment)

**Persons signing the resolution**

Please indicate the directors/ secretaries who signed the resolution :

- S0036442H / OW CHIN HOCK
- S0070715E / NG KEE CHOE
- S0234645A / CHEW CHOON SENG
- S1001765C / BARRY HENRY PATRICK DESKER
- S1069567H / TAN JIAK NGEE MICHAEL
- S1673157I / YIP WAI PING ANNABELLE
- S1852301I / HONG HAI @ HUANG HAI
- S2163476Z / CHENG WAI WING EDMUND
- S2580327B / RICHARD CHARLES HELFER

Please enter names of other corporate representatives who signed the resolution, if applicable :

**Declaration**

I, LIM HONG IENG SUSANNA, Professional body/service bureau, declare the information which has been submitted herein to be true to the best of my knowledge.

**Return of Allotment of Shares**

Please fill in the following information. Fields marked \* must be completed.

Resolution / Declaration	Share payable in cash	For a consideration other than cash	Share Capital / Allottees Particulars	List of Shareholders after the Allotment	Summary of Capital
--------------------------	-----------------------	-------------------------------------	---------------------------------------	--	--------------------

**Authorised Capital**

	Amount	Nominal Value per Share	Currency
Authorised Capital :	<b>200000000</b>	<b>.1</b>	<b>SINGAPORE DOLLAR ( 099 )</b>

Description of discrepancy :

**Return of Allotment of Shares (Payable in cash) \***

Applicable only if share is payable in cash

Class of Shares :	Ordinary	Preference	Others
Number of shares :	<input type="text" value="7800"/>	<input type="text"/>	<input type="text"/>
Amount paid or due and payable on each share	-----		
paid :	<input type="text" value="0.10"/>	<input type="text"/>	<input type="text"/>
due and payable :	<input type="text" value="0"/>	<input type="text"/>	<input type="text"/>
Amount of premium paid or payable on each share :	<input type="text" value="1.50"/>	<input type="text"/>	<input type="text"/>

<input type="button" value="Save"/>	<input type="button" value="Delete Issued Share"/>	<input type="button" value="Reset"/>	<input type="button" value="Back"/>
-------------------------------------	--	--------------------------------------	-------------------------------------



**Return of Allotment of Shares****Submit**

Please fill in the following information. Fields marked \* must be completed.

Resolution / Declaration	Share payable in cash	For a consideration other than cash	Share Capital / Allottees Particulars	List of Shareholders after the allotment	Summary of Capital
-----------------------------	--------------------------	---	---	---	-----------------------

**Particulars of Allottee****Please indicate whether the allottee is an Individual : \***

- Allottee is an Individual  
 Allottee is NOT an Individual

**If Allottee is an Individual :**Shareholder Category : \* **Individual**Identification No. : \*  **Retrieve Details**Identification Type : \*  Name : \* Nationality : \* Mobile No : Occupation : Email Address : Address Type : \*  
 Local  
 Foreign

Local Address (\* if Address Type is Local Address)

Postal Code :  **Retrieve Address**Block/House No. : Street Name : Unit : #  - Building/Estate Name : 

Foreign Address (\* if Address Type is Foreign Address)

Address : **If Allottee is NOT an Individual :**Shareholder Category : \*  **Search**

Registration No. : \*

198003912M

Retrieve Details

Name :

**THE CENTRAL DEPOSITORY (PTE) LIMITED**

Address Type :

**Local**

Local Address (\* if Address Type is Local Address)

Postal Code : **068804**

Block/House No. : **2**

Street Name : **SHENTON WAY**

Unit : # **19 - 00**

Building/Estate Name : **SGX CENTRE I**

Foreign Address (\* if Address Type is Foreign Address)

Address :

**Details of Shares Allotted** \* Please read instructions carefully before entering.

Note : If any share or shares is/are co-owned by 2 or more persons, please assign an alphabet e.g. A to denote the Group and enter the same in the box. Enter the same alphabet in the box for every allottee in the same group. Skip this box if share(s) are owned by only one person.

Group of Share that is co-owned:  
(Share Group)

If share(s) is/are co-owned, only one allottee is to enter details in (a), (b), (c), (d) and (e). Enter "0" (zero) for subsequent allottees in box (b) and leave blank for rest of the items.

a) Nominal Value per Share :

0.10

b) No. of shares allotted :

7800

c) Class of shares allotted :

Ordinary

d) Currency :

SINGAPORE DOLLAR (099)

e) Date of allotment :

25/11/2004

(dd/mm/yyyy)

Save

Reset

Back

**Return of Allotment of Shares****Submit**

Please fill in the following information. Fields marked \* must be completed.

<b>Resolution / Declaration</b>	<b>Share payable in cash</b>	<b>For a consideration other than cash</b>	<b>Share Capital / Allottees Particulars</b>	<b>List of Shareholders after Allotment</b>	<b>Summary of Capital</b>
-------------------------------------	----------------------------------	--	--	---	-------------------------------

**List of Allottees and their particulars****Identification****No./Registration Name  
No.****Shareholder Category**

198003912M	THE CENTRAL DEPOSITORY (PTE) LIMITED	Company / Foreign Branch
------------	---	--------------------------

If No. of shareholders exceeds 50, total No. of issued shares held by the remaining shareholders are :

<b>No. of Shares</b>	<b>Ordinary</b>	<b>Preference</b>	<b>Others</b>
	0	0	0

**Return of Allotment of Shares****Submit**

Please fill in the following information. Fields marked \* must be completed.

<u>Resolution / Declaration</u>	<u>Share payable in cash</u>	<u>For a consideration other than cash</u>	<u>Share Capital / Allottees Particulars</u>	<u>List of Shareholders after the allotment</u>	<u>Summary of Capital</u>
---------------------------------	------------------------------	--	--	---	---------------------------

**Share Capital (1)**

Currency :	<b>SINGAPORE DOLLAR (099)</b>		
Nominal Value per Share :	<b>0.10</b>		
Amount of Authorised Share Capital :	<b>200000000.00</b>		
Class of Shares :	Ordinary	Preference	Others
Amount of Issued Share Capital :	<b>102603942.50</b>	<b>0.00</b>	<b>0.00</b>
Amount of Paid-up Share Capital :	<b>102603942.50</b>	<b>0.00</b>	<b>0.00</b>

GST No. :M9-0008879-T

**RECEIPT**

Receipt No : ACR0000000954287A

Date/Time : 30/11/2004 10:14

Transaction  
No : C040533566

Agency : RCB - RCB

Application : BIZFILE PAYMENT SERVICE

Paid via : Deposit Service Account

EP Ref No :

**SINGAPORE AIRPORT TERMINAL SERVICES LIMITED**  
**20 AIRPORT BOULEVARD**  
**SATS INFLIGHT CATERING CENTRE 3**  
**SINGAPORE 819659**

<u>Sno Code/Description</u>	<u>Unit Price (S\$)</u>	<u>Qty</u>	<u>Amount</u>
1 Lodgment Of Return Of Allotment Of Share <b>COMPANY/BUSINESS NAME :</b> 197201770G / SINGAPORE AIRPORT TERMINAL SERVICES LIMITED	10.00	1	10.00
Total (S\$) :			10.00

**Deposit Service Account No. : 030066**  
**Balance Amount in Deposit Account : \$ 225.00**

This is a computer-generated receipt. No signature is required.

Please print a copy of the receipt for your reference.

[HOME](#)[LOGOUT](#)

**Return of Allotment of Shares****Submit**

Please fill in the following information. Fields marked \* must be completed.

Resolution/Declaration	Shares payable in cash	For a consideration other than cash	Share Capital/Allottees Particulars	List of Shareholders after the allotment	Summary of Capital
------------------------	------------------------	-------------------------------------	-------------------------------------	--	--------------------

**Record saved successfully.****Company Type**

Please click on appropriate button :

- company is listed on the securities exchange  
 company is an unlisted public company  
 company is a private company

**Power under Section 161 of the Companies Act \***

The directors have obtained the approval of the company in  Yes  No general meeting to issue shares.

**Resolution Made**

\* You are only required to fill in this section if the directors are not given the power under Section 161 of the Companies Act to issue shares.

Registration No. : **197201770G**Company Name : **SINGAPORE AIRPORT TERMINAL SERVICES LIMITED**Nature of Meeting : \* 

Place of Meeting : \*

Date of Meeting : \*  (dd/mm/yyyy)Resolution Type : \* Description : \*  
(max 2000 characters)Attachment : \*  
(copy of resolution)**Note :**

Uploaded file name will be changed by suffixing time-stamp with the actual file name as

**filenameyyyyMMddmmsstt****Browse...**

(Click 'Browse' to select file for attachment)

**Persons signing the resolution**

Please indicate the directors/ secretaries who signed the resolution :

- S0036442H / OW CHIN HOCK
- S0070715E / NG KEE CHOE
- S0234645A / CHEW CHOON SENG
- S1001765C / BARRY HENRY PATRICK DESKER
- S1069567H / TAN JIAK NGEER MICHAEL
- S1673157I / YIP WAI PING ANNABELLE
- S1852301I / HONG HAI @ HUANG HAI
- S2163476Z / CHENG WAI WING EDMUND
- S2580327B / RICHARD CHARLES HELFER

Please enter names of other corporate representatives who signed the resolution, if applicable :

**Declaration**

I, LIM HONG ENG SUSANNA, Professional body/service bureau, declare the information which has been submitted herein to be true to the best of my knowledge.

**Return of Allotment of Shares****Submit**

Please fill in the following information. Fields marked \* must be completed.

<u>Resolution / Declaration</u>	<u>Share payable in cash</u>	<u>For a consideration other than cash</u>	<u>Share Capital / Allottees Particulars</u>	<u>List of Shareholders after the Allotment</u>	<u>Summary of Capital</u>
---------------------------------	------------------------------	--	--	---	---------------------------

**Authorised Capital**

	<u>Amount</u>	<u>Nominal Value per Share</u>	<u>Currency</u>
Authorised Capital :	<b>200000000</b>	<b>.1</b>	<b>SINGAPORE DOLLAR ( 099 )</b>

Description of discrepancy :

**Return of Allotment of Shares (Payable in cash) \***

Applicable only if share is payable in cash

<u>Class of Shares :</u>	<u>Ordinary</u>	<u>Preference</u>	<u>Others</u>
Number of shares :	<input type="text" value="2600"/>	<input type="text"/>	<input type="text"/>
Amount paid or due and payable on each share	-----		
paid :	<input type="text" value="0.10"/>	<input type="text"/>	<input type="text"/>
due and payable :	<input type="text" value="0"/>	<input type="text"/>	<input type="text"/>
Amount of premium paid or payable on each share :	<input type="text" value="1.14"/>	<input type="text"/>	<input type="text"/>

**Save****Delete Issued Share****Reset****Back**



**Return of Allotment of Shares****Submit**

Please fill in the following information. Fields marked \* must be completed.

Resolution / Declaration	Share payable in cash	For a consideration other than cash	Share Capital / Allottees Particulars	List of Shareholders after the allotment	Summary of Capital
--------------------------	-----------------------	-------------------------------------	---------------------------------------	--	--------------------

**Particulars of Allottee****Please indicate whether the allottee is an Individual : \***

- Allottee is an Individual  
 Allottee is NOT an Individual

**If Allottee is an Individual :**Shareholder Category : \* **Individual**Identification No. : \*  **Retrieve Details**Identification Type : \*  ▼Name : \* Nationality : \*  ▼Mobile No : Occupation : Email Address : Address Type : \*  
 Local  
 Foreign

Local Address (\* if Address Type is Local Address)

Postal Code :  **Retrieve Address**Block/House No. :  ▼

Street Name :

Unit : #  - 

Building/Estate Name :

Foreign Address (\* if Address Type is Foreign Address)

Address : **If Allottee is NOT an Individual :**Shareholder Category : \*  ▼ **Search**

Name : **THE CENTRAL DEPOSITORY (PTE) LIMITED**Address Type : **Local**

Local Address (\* if Address Type is Local Address)

Postal Code : **068804**Block/House No. : **2**Street Name : **SHENTON WAY**Unit : # **19 - 00**Building/Estate Name : **SGX CENTRE I**

Foreign Address (\* if Address Type is Foreign Address)

Address :

**Details of Shares Allotted** \* Please read instructions carefully before entering.

Note : If any share or shares is/are co-owned by 2 or more persons, please assign an alphabet e.g. A to denote the Group and enter the same in the box. Enter the same alphabet in the box for every allottee in the same group. Skip this box if share(s) are owned by only one person.

Group of Share that is co-owned:  
(Share Group)

If share(s) is/are co-owned, only one allottee is to enter details in (a), (b), (c), (d) and (e). Enter "0" (zero) for subsequent allottees in box (b) and leave blank for rest of the items.

a) Nominal Value per Share :

b) No. of shares allotted :

c) Class of shares allotted :

d) Currency :

e) Date of allotment :

 (dd/mm/yyyy)

**Return of Allotment of Shares****Submit**

Please fill in the following information. Fields marked \* must be completed.

<b>Resolution / Declaration</b>	<b>Share payable in cash</b>	<b>For a consideration other than cash</b>	<b>Share Capital / Allottees Particulars</b>	<b>List of Shareholders after Allotment</b>	<b>Summary of Capital</b>
-------------------------------------	----------------------------------	--	--	---	-------------------------------

**List of Allottees and their particulars****Identification****No./Registration Name  
No.****Shareholder Category**

198003912M	THE CENTRAL DEPOSITORY (PTE) LIMITED	Company / Foreign Branch
------------	---	--------------------------

If No. of shareholders exceeds 50, total No. of issued shares held by the remaining shareholders are :

<b>No. of Shares</b>	<b>Ordinary</b>	<b>Preference</b>	<b>Others</b>
	0	0	0

**Return of Allotment of Shares****Submit**

Please fill in the following information. Fields marked \* must be completed.

Resolution / Declaration	Share payable in cash	For a consideration other than cash	Share Capital / Allottees Particulars	List of Shareholders after the allotment	Summary of Capital
<b>Share Capital (1)</b>					
Currency :	<b>SINGAPORE DOLLAR (099)</b>				
Nominal Value per Share :	<b>0.10</b>				
Amount of Authorised Share Capital :	<b>200000000.00</b>				
Class of Shares :	Ordinary	Preference	Others		
Amount of Issued Share Capital :	<b>102603162.50</b>	<b>0.00</b>	<b>0.00</b>		
Amount of Paid-up Share Capital :	<b>102603162.50</b>	<b>0.00</b>	<b>0.00</b>		

**RECEIPT**

Receipt No : ACR0000000947090A

Date/Time : 24/11/2004 10:49

Transaction  
No : C040525713

Agency : RCB - RCB

Application : BIZFILE PAYMENT SERVICE

Paid via : Deposit Service Account

EP Ref No :

**SINGAPORE AIRPORT TERMINAL SERVICES LIMITED**  
**20 AIRPORT BOULEVARD**  
**SATS INFLIGHT CATERING CENTRE 3**  
**SINGAPORE 819659**

---

<b>Sno Code/Description</b>	<b>Unit Price (S\$)</b>	<b>Qty</b>	<b>Amount</b>
1 Lodgment Of Return Of Allotment Of Share <b>COMPANY/BUSINESS NAME :</b> 197201770G / SINGAPORE AIRPORT TERMINAL SERVICES LIMITED	10.00	1	10.00
<b>Total (S\$) :</b>			<b>10.00</b>

---

**Deposit Service Account No. : 030066**  
**Balance Amount in Deposit Account : \$ 235.00**

This is a computer-generated receipt. No signature is required.

Please print a copy of the receipt for your reference.

<b>HOME</b>	<b>LOGOUT</b>
-------------	---------------

## Return of Allotment of Shares

Submit

Please fill in the following information. Fields marked \* must be completed.

Resolution/Declaration	Shares payable in cash	For a consideration other than cash	Share Capital/Allottees Particulars	List of Shareholders after the allotment	Summary of Capital
------------------------	---------------------------	---	---	---	-----------------------

Record saved successfully.

## Company Type

Please click on appropriate button :

- company is listed on the securities exchange  
 company is an unlisted public company  
 company is a private company

## Power under Section 161 of the Companies Act \*

The directors have obtained the approval of the company in  Yes  No general meeting to issue shares.

## Resolution Made

\* You are only required to fill in this section if the directors are not given the power under Section 161 of the Companies Act to issue shares.

Registration No. : **197201770G**

Company Name : **SINGAPORE AIRPORT TERMINAL SERVICES LIMITED**

Nature of Meeting : \*

Place of Meeting : \*

Date of Meeting: \*  (dd/mm/yyyy)

Resolution Type : \*

Description : \*  
(max 2000 characters)

Attachment : \*  
(copy of resolution)

## Note :

Uploaded file name will be changed by suffixing time-stamp with the actual file name as

filenameyyyyMMddmmsstt

(Click 'Browse' to select file for attachment)

**Persons signing the resolution**

Please indicate the directors/ secretaries who signed the resolution :

- S0036442H / OW CHIN HOCK
- S0070715E / NG KEE CHOE
- S0234645A / CHEW CHOON SENG
- S1001765C / BARRY HENRY PATRICK DESKER
- S1069567H / TAN JIAK NGEE MICHAEL
- S1673157I / YIP WAI PING ANNABELLE
- S1852301I / HONG HAI @ HUANG HAI
- S2163476Z / CHENG WAI WING EDMUND
- S2580327B / RICHARD CHARLES HELFER

Please enter names of other corporate representatives who signed the resolution, if applicable :

**Declaration**

I, LIM HONG ENG SUSANNA, Professional body/service bureau, declare the information which has been submitted herein to be true to the best of my knowledge.

**Return of Allotment of Shares**

[Submit](#)

Please fill in the following information. Fields marked \* must be completed.

<u>Resolution / Declaration</u>	Share payable in cash	For a consideration other than cash	Share Capital / Allottees Particulars	List of Shareholders after the Allotment	Summary of Capital
---------------------------------	-----------------------	-------------------------------------	---------------------------------------	--	--------------------

**Authorised Capital**

	Amount	Nominal Value per Share	Currency
Authorised Capital :	<b>200000000</b>	<b>.1</b>	<b>SINGAPORE DOLLAR ( 099 )</b>

Description of discrepancy :

**Return of Allotment of Shares (Payable in cash) \***

Applicable only if share is payable in cash

Class of Shares :	Ordinary	Preference	Others
Number of shares :	<input type="text" value="13000"/>	<input type="text"/>	<input type="text"/>
Amount paid or due and payable on each share			
paid :	<input type="text" value="0.10"/>	<input type="text"/>	<input type="text"/>
due and payable :	<input type="text" value="0"/>	<input type="text"/>	<input type="text"/>
Amount of premium paid or payable on each share :	<input type="text" value="1.50"/>	<input type="text"/>	<input type="text"/>

[Save](#)   [Delete Issued Share](#)   [Reset](#)   [Back](#)



**Return of Allotment of Shares****Submit**

Please fill in the following information. Fields marked \* must be completed.

<u>Resolution / Declaration</u>	<u>Share payable in cash</u>	<u>For a consideration other than cash</u>	<u>Share Capital / Allottees Particulars</u>	<u>List of Shareholders after the allotment</u>	<u>Summary of Capital</u>
---------------------------------	------------------------------	--	--	---	---------------------------

**Particulars of Allottee**

Please indicate whether the allottee is an Individual : \*

- Allottee is an Individual  
 Allottee is NOT an Individual

**If Allottee is an Individual :**Shareholder Category : \* **Individual**

Identification No. : \*

**Retrieve Details**

Identification Type : \*

NRIC 

Name : \*

Nationality : \*

Mobile No. :

Occupation :

Email Address :

Address Type : \*

- Local  
 Foreign

Local Address (\* if Address Type is Local Address)

Postal Code :

**Retrieve Address**

Block/House No. :

Street Name :

Unit : #

 - 

Building/Estate Name :

Foreign Address (\* if Address Type is Foreign Address)

Address :

**If Allottee is NOT an Individual :**

Shareholder Category : \*

Company / Foreign Branch **Search**

Name : THE CENTRAL DEPOSITORY (PTE) LIMITED

Address Type : Local

Local Address (\* if Address Type is Local Address)

Postal Code : 068804

Block/House No. : 2

Street Name : SHENTON WAY

Unit : # 19 - 00

Building/Estate Name : SGX CENTRE I

Foreign Address (\* if Address Type is Foreign Address)

Address :

**Details of Shares Allotted** \* Please read instructions carefully before entering.

Note : If any share or shares is/are co-owned by 2 or more persons, please assign an alphabet e.g. A to denote the Group and enter the same in the box. Enter the same alphabet in the box for every allottee in the same group. Skip this box if share(s) are owned by only one person.

Group of Share that is co-owned:  
(Share Group)

If share(s) is/are co-owned, only one allottee is to enter details in (a), (b), (c), (d) and (e). Enter "0" (zero) for subsequent allottees in box (b) and leave blank for rest of the items.

a) Nominal Value per Share :

b) No. of shares allotted :

c) Class of shares allotted :

d) Currency :

e) Date of allotment :  (dd/mm/yyyy)

**Return of Allotment of Shares****Submit**

Please fill in the following information. Fields marked \* must be completed.

<b>Resolution / Declaration</b>	<b>Share payable in cash</b>	<b>For a consideration other than cash</b>	<b>Share Capital / Allottees Particulars</b>	<b>List of Shareholders after Allotment</b>	<b>Summary of Capital</b>
-------------------------------------	----------------------------------	--	--	---	-------------------------------

**List of Allottees and their particulars****Identification****No./Registration Name  
No.****Shareholder Category**

198003912M	THE CENTRAL DEPOSITORY (PTE) LIMITED	Company / Foreign Branch
------------	---	--------------------------

If No. of shareholders exceeds 50, total No. of issued shares held by the remaining shareholders are :

<b>No. of Shares</b>	<b>Ordinary</b>	<b>Preference</b>	<b>Others</b>
	0	0	0

**Return of Allotment of Shares****Submit**

Please fill in the following information. Fields marked \* must be completed.

<u>Resolution / Declaration</u>	<u>Share payable in cash</u>	<u>For a consideration other than cash</u>	<u>Share Capital / Allottees Particulars</u>	<u>List of Shareholders after the allotment</u>	<u>Summary of Capital</u>
---------------------------------	------------------------------	--	--	---	---------------------------

**Share Capital (1)**

Currency :	<b>SINGAPORE DOLLAR (099)</b>		
Nominal Value per Share :	<b>0.10</b>		
Amount of Authorised Share Capital :	<b>200000000.00</b>		
Class of Shares :	Ordinary	Preference	Others
Amount of Issued Share Capital :	<b>102602902.50</b>	<b>0.00</b>	<b>0.00</b>
Amount of Paid-up Share Capital :	<b>102602902.50</b>	<b>0.00</b>	<b>0.00</b>

GST No. :M9-0008879-T

**RECEIPT**

Receipt No : ACR0000000946926A

Date/Time : 24/11/2004 09:39

Transaction  
No : C040525547

Agency : RCB - RCB

Application : BIZFILE PAYMENT SERVICE

Paid via : Deposit Service Account

EP Ref No :

**SINGAPORE AIRPORT TERMINAL SERVICES LIMITED**  
**20 AIRPORT BOULEVARD**  
**SATS INFLIGHT CATERING CENTRE 3**  
**SINGAPORE 819659**

<b>Sno</b>	<b>Code/Description</b>	<b>Unit Price (S\$)</b>	<b>Qty</b>	<b>Amount</b>
1	Lodgment Of Return Of Allotment Of Share <b>COMPANY/BUSINESS NAME :</b> 197201770G / SINGAPORE AIRPORT TERMINAL SERVICES LIMITED	10.00	1	10.00
<b>Total (S\$) :</b>				10.00

**Deposit Service Account No. : 030066**  
**Balance Amount in Deposit Account : \$ 245.00**

This is a computer-generated receipt. No signature is required.

Please print a copy of the receipt for your reference.

[HOME](#)[LOGOUT](#)

**Return of Allotment of Shares****Submit**

Please fill in the following information. Fields marked \* must be completed.

Resolution/Declaration	Shares payable in cash	For a consideration other than cash	Share Capital/Allottees Particulars	List of Shareholders after the allotment	Summary of Capital
------------------------	---------------------------	---	---	---	-----------------------

**Record saved successfully.****Company Type**

Please click on appropriate button :

- company is listed on the securities exchange  
 company is an unlisted public company  
 company is a private company

**Power under Section 161 of the Companies Act \***

The directors have obtained the approval of the company in  Yes  No general meeting to issue shares.

**Resolution Made**

\* You are only required to fill in this section if the directors are not given the power under Section 161 of the Companies Act to issue shares.

Registration No. : **197201770G**Company Name : **SINGAPORE AIRPORT TERMINAL SERVICES LIMITED**Nature of Meeting : \* 

Place of Meeting : \*

Date of Meeting: \*  (dd/mm/yyyy)Resolution Type : \*  Description : \*  
(max 2000 characters)
  

Attachment : \*  
(copy of resolution)**Note :**

Uploaded file name will be changed by suffixing time-stamp with the actual file name as

**filenameyyyyMMddmmsstt** **Browse...**

(Click 'Browse' to select file for attachment)

**Persons signing the resolution**

Please indicate the directors/ secretaries who signed the resolution :

- S0036442H / OW CHIN HOCK
- S0070715E / NG KEE CHOE
- S0234645A / CHEW CHOON SENG
- S1001765C / BARRY HENRY PATRICK DESKER
- S1069567H / TAN JIAK NGEE MICHAEL
- S1673157I / YIP WAI PING ANNABELLE
- S1852301I / HONG HAI @ HUANG HAI
- S2163476Z / CHENG WAI WING EDMUND
- S2580327B / RICHARD CHARLES HELFER

Please enter names of other corporate representatives who signed the resolution, if applicable :

**Declaration**

I, LIM HONG ENG SUSANNA, Professional body/service bureau, declare the information which has been submitted herein to be true to the best of my knowledge.

**Return of Allotment of Shares****Submit**

Please fill in the following information. Fields marked \* must be completed.

<u>Resolution / Declaration</u>	<u>Share payable in cash</u>	<u>For a consideration other than cash</u>	<u>Share Capital / Allottees Particulars</u>	<u>List of Shareholders after the Allotment</u>	<u>Summary of Capital</u>
---------------------------------	------------------------------	--	--	---	---------------------------

**Authorised Capital**

	Amount	Nominal Value per Share	Currency
Authorised Capital :	<b>200000000</b>	<b>.1</b>	<b>SINGAPORE DOLLAR ( 099 )</b>

Description of discrepancy :

**Return of Allotment of Shares (Payable in cash) \***

Applicable only if share is payable in cash

Class of Shares :	Ordinary	Preference	Others
Number of shares :	<input type="text" value="5200"/>	<input type="text"/>	<input type="text"/>
Amount paid or due and payable on each share			
paid :	<input type="text" value="0.10"/>	<input type="text"/>	<input type="text"/>
due and payable :	<input type="text" value="0"/>	<input type="text"/>	<input type="text"/>
Amount of premium paid or payable on each share :	<input type="text" value="1.14"/>	<input type="text"/>	<input type="text"/>

**Save****Delete Issued Share****Reset****Back**



**Return of Allotment of Shares**

Submit

Please fill in the following information. Fields marked \* must be completed.

Resolution / Declaration	Share payable in cash	For a consideration other than cash	Share Capital / Allottees Particulars	List of Shareholders after the allotment	Summary of Capital
--------------------------	-----------------------	-------------------------------------	---------------------------------------	--	--------------------

**Particulars of Allottee**

Please indicate whether the allottee is an Individual : \*

- Allottee is an Individual  
 Allottee is NOT an Individual

If Allottee is an Individual :

Shareholder Category : \* **Individual**

Identification No. : \*

Retrieve Details

Identification Type : \*

Name : \*

Nationality : \*

Mobile No. :

Occupation :

Email Address :

Address Type : \*

- Local  
 Foreign

Local Address (\* if Address Type is Local Address)

Postal Code :

Retrieve Address

Block/House No. :

Street Name :

Unit : #

 - 

Building/Estate Name :

Foreign Address (\* if Address Type is Foreign Address)

Address :

If Allottee is NOT an Individual :

Shareholder Category : \*

Search

Registration No. : \*

198003912M

Retrieve Details

Name :

THE CENTRAL DEPOSITORY (PTE) LIMITED

Address Type :

Local

Local Address (\* if Address Type is Local Address)

Postal Code : 068804

Block/House No. : 2

Street Name : SHENTON WAY

Unit : # 19 - 00

Building/Estate Name : SGX CENTRE I

Foreign Address (\* if Address Type is Foreign Address)

Address :

**Details of Shares Allotted** \* Please read instructions carefully before entering.

Note : If any share or shares is/are co-owned by 2 or more persons, please assign an alphabet e.g. A to denote the Group and enter the same in the box. Enter the same alphabet in the box for every allottee in the same group. Skip this box if share(s) are owned by only one person.

Group of Share that is co-owned:  
(Share Group)

If share(s) is/are co-owned, only one allottee is to enter details in (a), (b), (c), (d) and (e). Enter "0" (zero) for subsequent allottees in box (b) and leave blank for rest of the items.

a) Nominal Value per Share :

0.10

b) No. of shares allotted :

5200

c) Class of shares allotted :

Ordinary

d) Currency :

SINGAPORE DOLLAR (099)

e) Date of allotment :

22/11/2004

(dd/mm/yyyy)

Save

Reset

Back

**Return of Allotment of Shares****Submit**

Please fill in the following information. Fields marked \* must be completed.

<b>Resolution / Declaration</b>	<b>Share payable in cash</b>	<b>For a consideration other than cash</b>	<b>Share Capital / Allottees Particulars</b>	<b>List of Shareholders after Allotment</b>	<b>Summary of Capital</b>
-------------------------------------	----------------------------------	--	--	---	-------------------------------

**List of Allottees and their particulars****Identification****No./Registration Name  
No.****Shareholder Category**

198003912M	THE CENTRAL DEPOSITORY (PTE) LIMITED	Company / Foreign Branch
------------	---	--------------------------

If No. of shareholders exceeds 50, total No. of issued shares held by the remaining shareholders are :

<b>No. of Shares</b>	<b>Ordinary</b>	<b>Preference</b>	<b>Others</b>
	0	0	0

**Return of Allotment of Shares****Submit**

Please fill in the following information. Fields marked \* must be completed.

<u>Resolution / Declaration</u>	<u>Share payable in cash</u>	<u>For a consideration other than cash</u>	<u>Share Capital / Allottees Particulars</u>	<u>List of Shareholders after the allotment</u>	<u>Summary of Capital</u>
<b>Share Capital (1)</b>					
Currency :	<b>SINGAPORE DOLLAR (099)</b>				
Nominal Value per Share :	<b>0.10</b>				
Amount of Authorised Share Capital :	<b>200000000.00</b>				
Class of Shares :	Ordinary	Preference	Others		
Amount of Issued Share Capital :	<b>102601602.50</b>	<b>0.00</b>	<b>0.00</b>		
Amount of Paid-up Share Capital :	<b>102601602.50</b>	<b>0.00</b>	<b>0.00</b>		

GST No. :M9-0008879-T

**RECEIPT**

Receipt No : ACR0000000943667A

Date/Time : 22/11/2004 09:07

Transaction  
No : C040522164

Agency : RCB - RCB

Application : BIZFILE PAYMENT SERVICE

Paid via : Deposit Service Account

EP Ref No :

**SINGAPORE AIRPORT TERMINAL SERVICES LIMITED**  
**20 AIRPORT BOULEVARD**  
**SATS INFLIGHT CATERING CENTRE 3**  
**SINGAPORE 819659**

<b>Sno</b>	<b>Code/Description</b>	<b>Unit Price (S\$)</b>	<b>Qty</b>	<b>Amount</b>
1	Lodgment Of Return Of Allotment Of Share <b>COMPANY/BUSINESS NAME :</b> 197201770G / SINGAPORE AIRPORT TERMINAL SERVICES LIMITED	10.00	1	10.00
<b>Total (S\$) :</b>				<b>10.00</b>

**Deposit Service Account No. : 030066**  
**Balance Amount in Deposit Account : \$ 255.00**

This is a computer-generated receipt. No signature is required.

Please print a copy of the receipt for your reference.

[HOME](#)[LOGOUT](#)

**Return of Allotment of Shares****Submit**

Please fill in the following information. Fields marked \* must be completed.

Resolution/Declaration	Shares payable in cash	For a consideration other than cash	Share Capital/Allottees Particulars	List of Shareholders after the allotment	Summary of Capital
------------------------	------------------------	-------------------------------------	-------------------------------------	--	--------------------

**Record saved successfully.****Company Type**

Please click on appropriate button :

- company is listed on the securities exchange
- company is an unlisted public company
- company is a private company

**Power under Section 161 of the Companies Act \***

The directors have obtained the approval of the company in  Yes  No general meeting to issue shares.

**Resolution Made**

\* You are only required to fill in this section if the directors are not given the power under Section 161 of the Companies Act to issue shares.

Registration No. : **197201770G**Company Name : **SINGAPORE AIRPORT TERMINAL SERVICES LIMITED**Nature of Meeting : \* **Directors**

Place of Meeting : \*

Date of Meeting : \* (dd/mm/yyyy)

Resolution Type : \* **Director's**Description : \*  
(max 2000 characters)Attachment : \*  
(copy of resolution)**Note :**

Uploaded file name will be changed by suffixing time-stamp with the actual file name as

**filenameyyyyMMddmmsstt****Browse...**

(Click 'Browse' to select file for attachment)

**Persons signing the resolution**

Please indicate the directors/ secretaries who signed the resolution :

- S0036442H / OW CHIN HOCK
- S0070715E / NG KEE CHOE
- S0234645A / CHEW CHOON SENG
- S1001765C / BARRY HENRY PATRICK DESKER
- S1069567H / TAN JIAK NGEE MICHAEL
- S1673157I / YIP WAI PING ANNABELLE
- S1852301I / HONG HAI @ HUANG HAI
- S2163476Z / CHENG WAI WING EDMUND
- S2580327B / RICHARD CHARLES HELFER

Please enter names of other corporate representatives who signed the resolution, if applicable :

**Declaration**

I, LIM HONG ENG SUSANNA, Professional body/service bureau, declare the information which has been submitted herein to be true to the best of my knowledge.

**Return of Allotment of Shares**

Please fill in the following information. Fields marked \* must be completed.

Resolution / Declaration	Share payable in cash	For a consideration other than cash	Share Capital / Allottees Particulars	List of Shareholders after the Allotment	Summary of Capital
--------------------------	-----------------------	-------------------------------------	---------------------------------------	--	--------------------

**Authorised Capital**

	Amount	Nominal Value per Share	Currency
Authorised Capital :	<b>20000000</b>	<b>.1</b>	<b>SINGAPORE DOLLAR ( 099 )</b>

Description of discrepancy :

**Return of Allotment of Shares (Payable in cash) \***

Applicable only if share is payable in cash

Class of Shares :	Ordinary	Preference	Others
Number of shares :	<input type="text" value="5200"/>	<input type="text"/>	<input type="text"/>
Amount paid or due and payable on each share			
paid :	<input type="text" value="0.10"/>	<input type="text"/>	<input type="text"/>
due and payable :	<input type="text" value="0"/>	<input type="text"/>	<input type="text"/>
Amount of premium paid or payable on each share :	<input type="text" value="1.50"/>	<input type="text"/>	<input type="text"/>



**Return of Allotment of Shares****Submit**

Please fill in the following information. Fields marked \* must be completed.

Resolution / Declaration	Share payable in cash	For a consideration other than cash	Share Capital / Allottees Particulars	List of Shareholders after the allotment	Summary of Capital
-----------------------------	--------------------------	---	---	---	-----------------------

**Particulars of Allottee****Please indicate whether the allottee is an Individual : \***

- Allottee is an Individual  
 Allottee is NOT an Individual

**If Allottee is an Individual :**Shareholder Category : \* **Individual**

Identification No. : \*

**Retrieve Details**

Identification Type : \*

NRIC

Name : \*

Nationality : \*

Mobile No :

Occupation :

Email Address :

Address Type : \*

- Local  
 Foreign

Local Address (\* if Address Type is Local Address)

Postal Code :

**Retrieve Address**

Block/House No. :

Street Name :

Unit : #

 - 

Building/Estate Name :

Foreign Address (\* if Address Type is Foreign Address)

Address :

**If Allottee is NOT an Individual :**

Shareholder Category : \*

Company / Foreign Branch

**Search**

Registration No. : **THE CENTRAL DEPOSITORY (PTE) LIMITED**

Address Type : **Local**

Local Address (\* if Address Type is Local Address)

Postal Code : **068804**

Block/House No. : **2**

Street Name : **SHENTON WAY**

Unit : # **19 - 00**

Building/Estate Name : **SGX CENTRE I**

Foreign Address (\* if Address Type is Foreign Address)

Address :

**Details of Shares Allotted** \* Please read instructions carefully before entering.

Note : If any share or shares is/are co-owned by 2 or more persons, please assign an alphabet e.g..A to denote the Group and enter the same in the box. Enter the same alphabet in the box for every allottee in the same group. Skip this box if share(s) are owned by only one person.

Group of Share that is co-owned:  
(Share Group)

If share(s) is/are co-owned, only one allottee is to enter details in (a), (b), (c), (d) and (e). Enter "0" (zero) for subsequent allottees in box (b) and leave blank for rest of the items.

- a) Nominal Value per Share :
- b) No. of shares allotted :
- c) Class of shares allotted :
- d) Currency :
- e) Date of allotment :  (dd/mm/yyyy)

**Return of Allotment of Shares****Submit**

Please fill in the following information. Fields marked \* must be completed.

<b>Resolution / Declaration</b>	<b>Share payable in cash</b>	<b>For a consideration other than cash</b>	<b>Share Capital / Allottees Particulars</b>	<b>List of Shareholders after Allotment</b>	<b>Summary of Capital</b>
-------------------------------------	----------------------------------	--	--	---	-------------------------------

**List of Allottees and their particulars****Identification****No./Registration Name  
No.****Shareholder Category**

198003912M	THE CENTRAL DEPOSITORY (PTE) LIMITED	Company / Foreign Branch
------------	---	--------------------------

If No. of shareholders exceeds 50, total No. of issued shares held by the remaining shareholders are :

<b>No. of Shares</b>	<b>Ordinary</b>	<b>Preference</b>	<b>Others</b>
	0	0	0

**Return of Allotment of Shares****Submit**

Please fill in the following information. Fields marked \* must be completed.

<b>Resolution / Declaration</b>	<b>Share payable in cash</b>	<b>For a consideration other than cash</b>	<b>Share Capital / Allottees Particulars</b>	<b>List of Shareholders after the allotment</b>	<b>Summary of Capital</b>
<b>Share Capital (1)</b>					
Currency :	<b>SINGAPORE DOLLAR (099)</b>				
Nominal Value per Share :	<b>0.10</b>				
Amount of Authorised Share Capital :	<b>200000000.00</b>				
Class of Shares :	Ordinary	Preference	Others		
Amount of Issued Share Capital :	<b>102601082.50</b>	<b>0.00</b>	<b>0.00</b>		
Amount of Paid-up Share Capital :	<b>102601082.50</b>	<b>0.00</b>	<b>0.00</b>		

GST No. :M9-0008879-T

**RECEIPT**

Receipt No : ACR0000000943663A

Date/Time : 22/11/2004 09:02

Transaction No : C040522162

Agency : RCB - RCB

Application : BIZFILE PAYMENT SERVICE

Paid via : Deposit Service Account

EP Ref No :

**SINGAPORE AIRPORT TERMINAL SERVICES LIMITED**  
**20 AIRPORT BOULEVARD**  
**SATS INFLIGHT CATERING CENTRE 3**  
**SINGAPORE 819659**

---

<b>Sno Code/Description</b>	<b>Unit Price (S\$)</b>	<b>Qty</b>	<b>Amount</b>
1 Lodgment Of Return Of Allotment Of Share	10.00	1	10.00
<b>COMPANY/BUSINESS NAME :</b> 197201770G / SINGAPORE AIRPORT TERMINAL SERVICES LIMITED			
Total (S\$) :			10.00

---

**Deposit Service Account No. : 030066**  
**Balance Amount in Deposit Account : \$ 265.00**

This is a computer-generated receipt. No signature is required.

Please print a copy of the receipt for your reference.

[HOME](#)[LOGOUT](#)

**Return of Allotment of Shares**

Submit

Please fill in the following information. Fields marked \* must be completed.

Resolution/Declaration	Shares payable in cash	For a consideration other than cash	Share Capital/Allottees Particulars	List of Shareholders after the allotment	Summary of Capital
------------------------	------------------------	-------------------------------------	-------------------------------------	--	--------------------

**Record saved successfully.****Company Type**

Please click on appropriate button :

- company is listed on the securities exchange  
 company is an unlisted public company  
 company is a private company

**Power under Section 161 of the Companies Act \***

The directors have obtained the approval of the company in  Yes  No general meeting to issue shares.

**Resolution Made**

\* You are only required to fill in this section if the directors are not given the power under Section 161 of the Companies Act to issue shares.

Registration No. : **197201770G**Company Name : **SINGAPORE AIRPORT TERMINAL SERVICES LIMITED**

Nature of Meeting : \* Directors

Place of Meeting : \*

Date of Meeting : \* (dd/mm/yyyy)

Resolution Type : \* Director's

Description : \*  
(max 2000 characters)Attachment : \*  
(copy of resolution)**Note :**

Uploaded file name will be changed by suffixing time-stamp with the actual file name as

filenameyyyyMMddmmsstt

Browse..

(Click 'Browse' to select file for attachment)

### Persons signing the resolution

Please indicate the directors/ secretaries who signed the resolution :

- S0036442H / OW CHIN HOCK
- S0070715E / NG KEE CHOE
- S0234645A / CHEW CHOON SENG
- S1001765C / BARRY HENRY PATRICK DESKER
- S1069567H / TAN JIAK NGEE MICHAEL
- S1673157I / YIP WAI PING ANNABELLE
- S1852301I / HONG HAI @ HUANG HAI
- S2163476Z / CHENG WAI WING EDMUND
- S2580327B / RICHARD CHARLES HELFER

Please enter  
names of other  
corporate  
representatives  
who signed the  
resolution, if  
applicable :

### Declaration

I, LIM HONG ENG SUSANNA, Professional body/service bureau, declare the information which has been submitted herein to be true to the best of my knowledge.

Save

Reset

**Return of Allotment of Shares**

Submit

Please fill in the following information. Fields marked \* must be completed.

Resolution / Declaration	Share payable in cash	For a consideration other than cash	Share Capital / Allottees Particulars	List of Shareholders after the Allotment	Summary of Capital
--------------------------	-----------------------	-------------------------------------	---------------------------------------	--	--------------------

**Authorised Capital**

	Amount	Nominal Value per Share	Currency
Authorised Capital :	<b>200000000</b>	<b>.1</b>	<b>SINGAPORE DOLLAR ( 099 )</b>

Description of discrepancy :

**Return of Allotment of Shares (Payable in cash) \***

Applicable only if share is payable in cash

Class of Shares :	Ordinary	Preference	Others
Number of shares :	2600		
Amount paid or due and payable on each share			
paid :	0.10		
due and payable :	0		
Amount of premium paid or payable on each share :	1.14		

Save

Delete Issued Share

Reset

Back



**Return of Allotment of Shares****Submit**

Please fill in the following information. Fields marked \* must be completed.

Resolution / Declaration	Share payable in cash	For a consideration other than cash	Share Capital / Allottees Particulars	List of Shareholders after the allotment	Summary of Capital
--------------------------	-----------------------	-------------------------------------	---------------------------------------	--	--------------------

**Particulars of Allottee**

Please indicate whether the allottee is an Individual : \*

- Allottee is an Individual  
 Allottee is NOT an Individual

If Allottee is an Individual :

Shareholder Category : \* **Individual**

Identification No. : \*

**Retrieve Details**

Identification Type : \*

NRIC 

Name : \*

Nationality : \*

Mobile No. :

Occupation :

Email Address :

Address Type : \*

- Local  
 Foreign

Local Address (\* if Address Type is Local Address)

Postal Code :

**Retrieve Address**

Block/House No. :

Street Name :

Unit : #

 - 

Building/Estate Name :

Foreign Address (\* if Address Type is Foreign Address)

Address :

If Allottee is NOT an Individual :

Shareholder Category : \*

Company / Foreign Branch **Search**

Registration No. : \*    
Name : **THE CENTRAL DEPOSITORY (PTE) LIMITED**

Address Type : **Local**

Local Address (\* if Address Type is Local Address)

Postal Code : **068804**

Block/House No. : **2**

Street Name : **SHENTON WAY**

Unit : # **19 - 00**

Building/Estate Name : **SGX CENTRE I**

Foreign Address (\* if Address Type is Foreign Address)

Address :

**Details of Shares Allotted** \* Please read instructions carefully before entering.

Note : If any share or shares is/are co-owned by 2 or more persons, please assign an alphabet e.g. A to denote the Group and enter the same in the box. Enter the same alphabet in the box for every allottee in the same group. Skip this box if share(s) are owned by only one person.

Group of Share that is co-owned:  
(Share Group)

If share(s) is/are co-owned, only one allottee is to enter details in (a), (b), (c), (d) and (e). Enter "0" (zero) for subsequent allottees in box (b) and leave blank for rest of the items.

a) Nominal Value per Share :   
b) No. of shares allotted :   
c) Class of shares allotted :   
d) Currency :   
e) Date of allotment :  (dd/mm/yyyy)

**Return of Allotment of Shares****Submit**

Please fill in the following information. Fields marked \* must be completed.

<b>Resolution / Declaration</b>	<b>Share payable in cash</b>	<b>For a consideration other than cash</b>	<b>Share Capital / Allottees Particulars</b>	<b>List of Shareholders after Allotment</b>	<b>Summary of Capital</b>
-------------------------------------	----------------------------------	--	--	---	-------------------------------

**List of Allottees and their particulars****Identification****No./Registration Name  
No.****Shareholder Category**

198003912M	THE CENTRAL DEPOSITORY (PTE) LIMITED	Company / Foreign Branch
------------	---	--------------------------

If No. of shareholders exceeds 50, total No. of issued shares held by the remaining shareholders are :

	<b>Ordinary</b>	<b>Preference</b>	<b>Others</b>
<b>No. of Shares</b>	<b>0</b>	<b>0</b>	<b>0</b>

**Return of Allotment of Shares****Submit**

Please fill in the following information. Fields marked \* must be completed.

Resolution / Declaration	Share payable in cash	For a consideration other than cash	Share Capital / Allottees Particulars	List of Shareholders after the allotment	Summary of Capital
--------------------------	-----------------------	-------------------------------------	---------------------------------------	--	--------------------

**Share Capital (1)**

Currency :	<b>SINGAPORE DOLLAR (099)</b>		
Nominal Value per Share :	<b>0.10</b>		
Amount of Authorised Share Capital :	<b>200000000.00</b>		
Class of Shares :	Ordinary	Preference	Others
Amount of Issued Share Capital :	<b>102600562.50</b>	<b>0.00</b>	<b>0.00</b>
Amount of Paid-up Share Capital :	<b>102600562.50</b>	<b>0.00</b>	<b>0.00</b>

GST No. :M9-0008879-T

**RECEIPT**

Receipt No : ACR0000000933463A

Date/Time : 10/11/2004 11:04

Transaction  
No : C040511357

Agency : RCB - RCB

Application : BIZFILE PAYMENT SERVICE

Paid via : Deposit Service Account

EP Ref No :

**SINGAPORE AIRPORT TERMINAL SERVICES LIMITED**  
**20 AIRPORT BOULEVARD**  
**SATS INFLIGHT CATERING CENTRE 3**  
**SINGAPORE 819659**

<b>Sno Code/Description</b>	<b>Unit Price (S\$)</b>	<b>Qty</b>	<b>Amount</b>
1 Lodgment Of Return Of Allotment Of Share <b>COMPANY/BUSINESS NAME :</b> 197201770G / SINGAPORE AIRPORT TERMINAL SERVICES LIMITED	10.00	1	10.00
<b>Total (S\$) :</b>			<b>10.00</b>

**Deposit Service Account No. : 030066**  
**Balance Amount in Deposit Account : \$ 285.00**

This is a computer-generated receipt. No signature is required.

Please print a copy of the receipt for your reference.

[HOME](#)[LOGOUT](#)

**Return of Allotment of Shares**

Submit

Please fill in the following information. Fields marked \* must be completed.

Resolution/Declaration	Shares payable in cash	For a consideration other than cash	Share Capital/Allottees Particulars	List of Shareholders after the allotment	Summary of Capital
------------------------	---------------------------	---	---	---	-----------------------

**Record saved successfully.****Company Type**

Please click on appropriate button :

- company is listed on the securities exchange  
 company is an unlisted public company  
 company is a private company

**Power under Section 161 of the Companies Act \***

The directors have obtained the approval of the company in  
 general meeting to issue shares.
  Yes  
 No

**Resolution Made**

\* You are only required to fill in this section if the directors are not given the power under Section 161 of the Companies Act to issue shares.

Registration No. : **197201770G**Company Name : **SINGAPORE AIRPORT TERMINAL SERVICES LIMITED**

Nature of Meeting : \* Directors

Place of Meeting : \*

Date of Meeting : \* (dd/mm/yyyy)

Resolution Type : \* Director's

Description : \*  
(max 2000 characters)Attachment : \*  
(copy of resolution)**Note :**

Uploaded file name will be changed by suffixing time-stamp with the actual file name as

**filenameyyyyMMddmmsstt**

Browse...

(Click 'Browse' to select file for attachment)

**Persons signing the resolution**

Please indicate the directors/ secretaries who signed the resolution :

- S0036442H / OW CHIN HOCK
- S0070715E / NG KEE CHOE
- S0234645A / CHEW CHOON SENG
- S1001765C / BARRY HENRY PATRICK DESKER
- S1069567H / TAN JIAK NGEE MICHAEL
- S1673157I / YIP WAI PING ANNABELLE
- S1852301I / HONG HAI @ HUANG HAI
- S2163476Z / CHENG WAI WING EDMUND
- S2580327B / RICHARD CHARLES HELFER

Please enter names of other corporate representatives who signed the resolution, if applicable :

**Declaration**

I, LIM HONG ENG SUSANNA, Professional body/service bureau, declare the information which has been submitted herein to be true to the best of my knowledge.

**Return of Allotment of Shares****Submit**

Please fill in the following information. Fields marked \* must be completed.

<u>Resolution / Declaration</u>	Share payable in cash	For a consideration other than cash	Share Capital / Allottees Particulars	List of Shareholders after the Allotment	Summary of Capital
---------------------------------	-----------------------	-------------------------------------	---------------------------------------	--	--------------------

**Authorised Capital**

	Amount	Nominal Value per Share	Currency
Authorised Capital :	<b>200000000</b>	<b>.1</b>	<b>SINGAPORE DOLLAR ( 099 )</b>

Description of discrepancy :

**Return of Allotment of Shares (Payable in cash) \***

Applicable only if share is payable in cash

Class of Shares :	Ordinary	Preference	Others
Number of shares :	28600		
Amount paid or due and payable on each share			
paid :	0.10		
due and payable :	0		
Amount of premium paid or payable on each share :	1.50		

**Save****Delete Issued Share****Reset****Back**



**Return of Allotment of Shares****Submit**

Please fill in the following information. Fields marked \* must be completed.

Resolution / Declaration	Share payable in cash	For a consideration other than cash	Share Capital / Allottees Particulars	List of Shareholders after the allotment	Summary of Capital
--------------------------	-----------------------	-------------------------------------	---------------------------------------	--	--------------------

**Particulars of Allottee****Please indicate whether the allottee is an Individual : \***

- Allottee is an Individual
- Allottee is NOT an Individual

**If Allottee is an Individual :**Shareholder Category : \* **Individual**Identification No. : \*  **Retrieve Details**Identification Type : \* Name : \* Nationality : \* Mobile No : Occupation : Email Address : Address Type : \*  Local  Foreign

Local Address (\* if Address Type is Local Address)

Postal Code :  **Retrieve Address**Block/House No. : 

Street Name :

Unit : #  - 

Building/Estate Name :

Foreign Address (\* if Address Type is Foreign Address)

Address :   
**If Allottee is NOT an Individual :**Shareholder Category : \*  **Search**

Registration No. : \*

198003912M

Retrieve Details

Name :

**THE CENTRAL DEPOSITORY (PTE) LIMITED**

Address Type :

**Local**

Local Address (\* if Address Type is Local Address)

Postal Code : **068804**

Block/House No. : **2**

Street Name : **SHENTON WAY**

Unit : # **19 - 00**

Building/Estate Name : **SGX CENTRE I**

Foreign Address (\* if Address Type is Foreign Address)

Address :

**Details of Shares Allotted** \* Please read instructions carefully before entering.

Note : If any share or shares is/are co-owned by 2 or more persons, please assign an alphabet e.g. A to denote the Group and enter the same in the box. Enter the same alphabet in the box for every allottee in the same group. Skip this box if share(s) are owned by only one person.

Group of Share that is co-owned:  
(Share Group)

If share(s) is/are co-owned, only one allottee is to enter details in (a), (b), (c), (d) and (e). Enter "0" (zero) for subsequent allottees in box (b) and leave blank for rest of the items.

a) Nominal Value per Share :

0.10

b) No. of shares allotted :

28600

c) Class of shares allotted :

Ordinary

d) Currency :

SINGAPORE DOLLAR (099)

e) Date of allotment :

05/11/2004 (dd/mm/yyyy)

Save Reset Back

**Return of Allotment of Shares****Submit**

Please fill in the following information. Fields marked \* must be completed.

Resolution / Declaration	Share payable in cash	For a consideration other than cash	Share Capital / Allottees Particulars	List of Shareholders after Allotment	Summary of Capital
-----------------------------	--------------------------	---	---	--	-----------------------

**List of Allottees and their particulars****Identification****No./Registration Name  
No.****Shareholder Category**

198003912M	THE CENTRAL DEPOSITORY (PTE) LIMITED	Company / Foreign Branch
------------	---	--------------------------

If No. of shareholders exceeds 50, total No. of issued shares held by the remaining shareholders are :

<b>No. of Shares</b>	<b>Ordinary</b>	<b>Preference</b>	<b>Others</b>
	0	0	0

**Return of Allotment of Shares****Submit**

Please fill in the following information. Fields marked \* must be completed.

<u>Resolution / Declaration</u>	<u>Share payable in cash</u>	<u>For a consideration other than cash</u>	<u>Share Capital / Allottees Particulars</u>	<u>List of Shareholders after the allotment</u>	<u>Summary of Capital</u>
---------------------------------	------------------------------	--	--	---	---------------------------

**Share Capital (1)**

Currency :	<b>SINGAPORE DOLLAR (099)</b>		
Nominal Value per Share :	<b>0.10</b>		
Amount of Authorised Share Capital :	<b>200000000.00</b>		
Class of Shares :	Ordinary	Preference	Others
Amount of Issued Share Capital :	<b>102600302.50</b>	<b>0.00</b>	<b>0.00</b>
Amount of Paid-up Share Capital :	<b>102600302.50</b>	<b>0.00</b>	<b>0.00</b>

GST No. :M9-0008879-T

**RECEIPT**

Receipt No : ACR0000000933441A

Date/Time : 10/11/2004 10:58

Transaction  
No : C040511332

Agency : RCB - RCB

Application : BIZFILE PAYMENT SERVICE

Paid via : Deposit Service Account

EP Ref No :

**SINGAPORE AIRPORT TERMINAL SERVICES LIMITED**  
**20 AIRPORT BOULEVARD**  
**SATS INFLIGHT CATERING CENTRE 3**  
**SINGAPORE 819659**

---

<b>Sno Code/Description</b>	<b>Unit Price (S\$)</b>	<b>Qty</b>	<b>Amount</b>
1 Lodgment Of Return Of Allotment Of Share <b>COMPANY/BUSINESS NAME :</b> 197201770G / SINGAPORE AIRPORT TERMINAL SERVICES LIMITED	10.00	1	10.00
<hr/>			
Total (S\$) :			10.00

---

**Deposit Service Account No. : 030066**  
**Balance Amount in Deposit Account : \$ 295.00**

This is a computer-generated receipt. No signature is required.

Please print a copy of the receipt for your reference.

[HOME](#)[LOGOUT](#)

**Return of Allotment of Shares****Submit**

Please fill in the following information. Fields marked \* must be completed.

Resolution/Declaration	Shares payable in cash	For a consideration other than cash	Share Capital/Allottees Particulars	List of Shareholders after the allotment	Summary of Capital
------------------------	---------------------------	---	---	---	-----------------------

**Record saved successfully.****Company Type**

Please click on appropriate button :

- company is listed on the securities exchange  
 company is an unlisted public company  
 company is a private company

**Power under Section 161 of the Companies Act \***

The directors have obtained the approval of the company in  Yes  No general meeting to issue shares.

**Resolution Made**

\* You are only required to fill in this section if the directors are not given the power under Section 161 of the Companies Act to issue shares.

Registration No. : **197201770G**Company Name : **SINGAPORE AIRPORT TERMINAL SERVICES LIMITED**Nature of Meeting : \*  ▼

Place of Meeting : \*

Date of Meeting: \*  (dd/mm/yyyy)Resolution Type : \*  ▼Description : \*  
(max 2000 characters)
  

Attachment : \*  
(copy of resolution)**Note :**

Uploaded file name will be changed by suffixing time-stamp with the actual file name as

**filenameyyyyMMddmmsstt**
 

(Click 'Browse' to select file for attachment)

### Persons signing the resolution

Please indicate the directors/ secretaries who signed the resolution :

- S0036442H / OW CHIN HOCK
- S0070715E / NG KEE CHOE
- S0234645A / CHEW CHOON SENG
- S1001765C / BARRY HENRY PATRICK DESKER
- S1069567H / TAN JIAK NGEE MICHAEL
- S1673157I / YIP WAI PING ANNABELLE
- S1852301I / HONG HAI @ HUANG HAI
- S2163476Z / CHENG WAI WING EDMUND
- S2580327B / RICHARD CHARLES HELFER

Please enter names of other corporate representatives who signed the resolution, if applicable :

### Declaration

I, LIM HONG ENG SUSANNA, Professional body/service bureau, declare the information which has been submitted herein to be true to the best of my knowledge.

**Return of Allotment of Shares****Submit**

Please fill in the following information. Fields marked \* must be completed.

<u>Resolution / Declaration</u>	Share payable in cash	For a consideration other than cash	Share Capital / Allottees Particulars	List of Shareholders after the Allotment	Summary of Capital
---------------------------------	-----------------------	-------------------------------------	---------------------------------------	--	--------------------

**Authorised Capital**

	Amount	Nominal Value per Share	Currency
Authorised Capital :	<b>200000000</b>	<b>.1</b>	<b>SINGAPORE DOLLAR ( 099 )</b>

Description of discrepancy :

**Return of Allotment of Shares (Payable in cash) \***

Applicable only if share is payable in cash

Class of Shares :	Ordinary	Preference	Others
Number of shares :	<input type="text" value="13000"/>	<input type="text"/>	<input type="text"/>
Amount paid or due and payable on each share			
paid :	<input type="text" value="0.10"/>	<input type="text"/>	<input type="text"/>
due and payable :	<input type="text" value="0"/>	<input type="text"/>	<input type="text"/>
Amount of premium paid or payable on each share :	<input type="text" value="1.14"/>	<input type="text"/>	<input type="text"/>

<b>Save</b>	<b>Delete Issued Share</b>	<b>Reset</b>	<b>Back</b>
-------------	----------------------------	--------------	-------------



**Return of Allotment of Shares**

Submit

Please fill in the following information. Fields marked \* must be completed.

<u>Resolution / Declaration</u>	<u>Share payable in cash</u>	<u>For a consideration other than cash</u>	<u>Share Capital / Allottees Particulars</u>	<u>List of Shareholders after the allotment</u>	<u>Summary of Capital</u>
-------------------------------------	----------------------------------	--	--	---	-------------------------------

**Particulars of Allottee**

Please indicate whether the allottee is an Individual : \*

- Allottee is an Individual  
 Allottee is NOT an Individual ✓

If Allottee is an Individual :

Shareholder Category : \* **Individual**

Identification No. : \*

Retrieve Details

Identification Type : \*

NRIC 

Name : \*

Nationality : \*

Mobile No :

Occupation :

Email Address :

Address Type : \*

- Local  
 Foreign

Local Address (\* if Address Type is Local Address)

Postal Code :

Retrieve Address

Block/House No. :

Street Name :

Unit : #

 - 

Building/Estate Name :

Foreign Address (\* if Address Type is Foreign Address)

Address :

If Allottee is NOT an Individual :

Shareholder Category : \*

Company / Foreign Branch 

Search

Registration No. : \*

198003912M

Retrieve Details

Name :

**THE CENTRAL DEPOSITORY (PTE) LIMITED**

Address Type :

**Local**

Local Address (\* if Address Type is Local Address)

Postal Code : **068804**

Block/House No. : **2**

Street Name : **SHENTON WAY**

Unit : # **19 - 00**

Building/Estate Name : **SGX CENTRE I**

Foreign Address (\* if Address Type is Foreign Address)

Address :

**Details of Shares Allotted** \* Please read instructions carefully before entering.

Note : If any share or shares is/are co-owned by 2 or more persons, please assign an alphabet e.g. A to denote the Group and enter the same in the box. Enter the same alphabet in the box for every allottee in the same group. Skip this box if share(s) are owned by only one person.

Group of Share that is co-owned:  
(Share Group)

If share(s) is/are co-owned, only one allottee is to enter details in (a), (b), (c), (d) and (e). Enter "0" (zero) for subsequent allottees in box (b) and leave blank for rest of the items.

a) Nominal Value per Share :

0.10

b) No. of shares allotted :

13000

c) Class of shares allotted :

Ordinary

d) Currency :

SINGAPORE DOLLAR (099)

e) Date of allotment :

05/11/2004 (dd/mm/yyyy)

Save

Reset

Back

**Return of Allotment of Shares**

Submit

Please fill in the following information. Fields marked \* must be completed.

<b>Resolution / Declaration</b>	<b>Share payable in cash</b>	<b>For a consideration other than cash</b>	<b>Share Capital / Allottees Particulars</b>	<b>List of Shareholders after Allotment</b>	<b>Summary of Capital</b>
-------------------------------------	----------------------------------	--	--	---	-------------------------------

**List of Allottees and their particulars****Identification****No./Registration Name  
No.****Shareholder Category**

198003912M	THE CENTRAL DEPOSITORY (PTE) LIMITED	Company / Foreign Branch
------------	---	--------------------------

If No. of shareholders exceeds 50, total No. of issued shares held by the remaining shareholders are :

	<b>Ordinary</b>	<b>Preference</b>	<b>Others</b>
<b>No. of Shares</b>	<b>0</b>	<b>0</b>	<b>0</b>

**Return of Allotment of Shares****Submit**

Please fill in the following information. Fields marked \* must be completed.

<u>Resolution / Declaration</u>	<u>Share payable in cash</u>	<u>For a consideration other than cash</u>	<u>Share Capital / Allottees Particulars</u>	<u>List of Shareholders after the allotment</u>	<u>Summary of Capital</u>
<b>Share Capital (1)</b>					
Currency :	<b>SINGAPORE DOLLAR (099)</b>				
Nominal Value per Share :	<b>0.10</b>				
Amount of Authorised Share Capital :	<b>200000000.00</b>				
Class of Shares :	Ordinary	Preference	Others		
Amount of Issued Share Capital :	<b>102597442.50</b>	<b>0.00</b>	<b>0.00</b>		
Amount of Paid-up Share Capital :	<b>102597442.50</b>	<b>0.00</b>	<b>0.00</b>		

GST No. :M9-0008879-T

**RECEIPT**

Receipt No : ACR0000000933420A

Date/Time : 10/11/2004 10:53

Transaction No : C040511313

Agency : RCB - RCB

Application : BIZFILE PAYMENT SERVICE

Paid via : Deposit Service Account

EP Ref No :

**SINGAPORE AIRPORT TERMINAL SERVICES LIMITED**  
**20 AIRPORT BOULEVARD**  
**SATS INFLIGHT CATERING CENTRE 3**  
**SINGAPORE 819659**

---

<b>Sno Code/Description</b>	<b>Unit Price (S\$)</b>	<b>Qty</b>	<b>Amount</b>
1 Lodgment Of Return Of Allotment Of Share <b>COMPANY/BUSINESS NAME :</b> 197201770G / SINGAPORE AIRPORT TERMINAL SERVICES LIMITED	10.00	1	10.00
<b>Total (S\$) :</b>			<b>10.00</b>

---

**Deposit Service Account No. : 030066**  
**Balance Amount in Deposit Account : \$ 305.00**

This is a computer-generated receipt. No signature is required.

Please print a copy of the receipt for your reference.

[HOME](#)[LOGOUT](#)

**LOCAL COMPANY TRANSACTIONS**[HOME](#) [LOGOUT](#)**Return of Allotment of Shares**[Submit](#)

Please fill in the following information. Fields marked \* must be completed.

Resolution/Declaration	Shares payable in cash	For a consideration other than cash	Share Capital/Allottees Particulars	List of Shareholders after the allotment	Summary of Capital
------------------------	---------------------------	---	---	---	-----------------------

**Record saved successfully.****Company Type**

Please click on appropriate button :

- company is listed on the securities exchange
- company is an unlisted public company
- company is a private company

**Power under Section 161 of the Companies Act \***

The directors have obtained  
the approval of the company in  Yes  
general meeting to issue  No  
shares.

**Resolution Made**

\* You are only required to fill in this section if the directors are not given the power under Section 161 of the Companies Act to issue shares.

Registration No. : **197201770G**Company Name : **SINGAPORE AIRPORT TERMINAL SERVICES LIMITED**Nature of Meeting : \*  ▼Place of Meeting : \*   
Date of Meeting : \*  (dd/mm/yyyy)Resolution Type : \*  ▼Description : \*  
(max 2000 characters) Attachment : \*  
(copy of resolution)**Note :**  [Browse...](#)

Uploaded file name will be  
changed by suffixing time-  
stamp with the actual file  
name as

(Click 'Browse' to select file for attachment)

**filenameyyyyMMddmmsstt**

**Persons signing the resolution**

Please indicate the directors/ secretaries who signed the resolution :

- S0036442H / OW CHIN HOCK
- S0070715E / NG KEE CHOE
- S0234645A / CHEW CHOON SENG
- S1001765C / BARRY HENRY PATRICK DESKER
- S1069567H / TAN JIAK NGEE MICHAEL
- S1673157I / YIP WAI PING ANNABELLE
- S1852301I / HONG HAI @ HUANG HAI
- S2163476Z / CHENG WAI WING EDMUND
- S2580327B / RICHARD CHARLES HELFER

Please enter names of other corporate representatives who signed the resolution, if applicable :

**Declaration**

I, LIM HONG ENG SUSANNA, Professional body/service bureau, declare the information which has been submitted herein to be true to the best of my knowledge.

**Return of Allotment of Shares**

Submit

Please fill in the following information. Fields marked \* must be completed.

<b>Resolution / Declaration</b>	<b>Share payable in cash</b>	<b>For a consideration other than cash</b>	<b>Share Capital / Allottees Particulars</b>	<b>List of Shareholders after the Allotment</b>	<b>Summary of Capital</b>
-------------------------------------	----------------------------------	--	--	---	-------------------------------

**Authorised Capital**

	<b>Amount</b>	<b>Nominal Value per Share</b>	<b>Currency</b>
Authorised Capital :	<b>200000000</b>	<b>.1</b>	<b>SINGAPORE DOLLAR ( 099 )</b>

Description of discrepancy :

**Return of Allotment of Shares (Payable in cash) \***

Applicable only if share is payable in cash

<b>Class of Shares :</b>	<b>Ordinary</b>	<b>Preference</b>	<b>Others</b>
Number of shares :	<input type="text" value="13000"/>	<input type="text"/>	<input type="text"/>
Amount paid or due and payable on each share			
paid :	<input type="text" value="0.10"/>	<input type="text"/>	<input type="text"/>
due and payable :	<input type="text" value="0"/>	<input type="text"/>	<input type="text"/>
Amount of premium paid or payable on each share :	<input type="text" value="1.70"/>	<input type="text"/>	<input type="text"/>

<input type="button" value="Save"/>	<input type="button" value="Delete Issued Share"/>	<input type="button" value="Reset"/>	<input type="button" value="Back"/>
-------------------------------------	--	--------------------------------------	-------------------------------------



**Return of Allotment of Shares**

Submit

Please fill in the following information. Fields marked \* must be completed.

Resolution /  
DeclarationShare payable in  
cashFor a  
consideration  
other than cashShare Capital /  
Allottees  
ParticularsList of  
Shareholders  
after the  
allotmentSummary  
of Capital**Particulars of Allottee****Please indicate whether the allottee is an Individual : \***

- Allottee is an Individual  
 Allottee is NOT an Individual

**If Allottee is an Individual :**Shareholder Category : \* **Individual**

Identification No. : \*

Retrieve Details

Identification Type : \*

NRIC 

Name : \*

Nationality : \*

Mobile No. :

Occupation :

Email Address :

Address Type : \*

- Local  
 Foreign

Local Address (\* if Address Type is Local Address)

Postal Code :

Retrieve Address

Block/House No. :

Street Name :

Unit : #

 - 

Building/Estate Name :

Foreign Address (\* if Address Type is Foreign Address)

Address :

**If Allottee is NOT an Individual :**

Shareholder Category : \*

Company / Foreign Branch 

Search

Registration No. : \*

198003912M

Retrieve Details

Name :

**THE CENTRAL DEPOSITORY (PTE) LIMITED**

Address Type :

**Local**

Local Address (\* if Address Type is Local Address)

Postal Code : **068804**

Block/House No. : **2**

Street Name : **SHENTON WAY**

Unit : # **19 - 00**

Building/Estate Name : **SGX CENTRE I**

Foreign Address (\* if Address Type is Foreign Address)

Address :

**Details of Shares Allotted** \* Please read instructions carefully before entering.

Note : If any share or shares is/are co-owned by 2 or more persons, please assign an alphabet e.g. A to denote the Group and enter the same in the box. Enter the same alphabet in the box for every allottee in the same group. Skip this box if share(s) are owned by only one person.

Group of Share that is co-owned:  
(Share Group)

If share(s) is/are co-owned, only one allottee is to enter details in (a), (b), (c), (d) and (e). Enter "0" (zero) for subsequent allottees in box (b) and leave blank for rest of the items.

a) Nominal Value per Share :

b) No. of shares allotted :

c) Class of shares allotted :

d) Currency :

e) Date of allotment :

 (dd/mm/yyyy)

**Return of Allotment of Shares****Submit**

Please fill in the following information. Fields marked \* must be completed.

<b>Resolution / Declaration</b>	<b>Share payable in cash</b>	<b>For a <u>consideration</u> other than cash</b>	<b>Share Capital / Allottees Particulars</b>	<b>List of Shareholders after Allotment</b>	<b>Summary of Capital</b>
-------------------------------------	----------------------------------	---	--	---	-------------------------------

**List of Allottees and their particulars****Identification****No./Registration Name  
No.****Shareholder Category**

198003912M	THE CENTRAL DEPOSITORY (PTE) LIMITED	Company / Foreign Branch
------------	---	--------------------------

If No. of shareholders exceeds 50, total No. of issued shares held by the remaining shareholders are :

	<b>Ordinary</b>	<b>Preference</b>	<b>Others</b>
<b>No. of Shares</b>	<b>0</b>	<b>0</b>	<b>0</b>

**Return of Allotment of Shares****Submit**

Please fill in the following information. Fields marked \* must be completed.

<u>Resolution / Declaration</u>	<u>Share payable in cash</u>	<u>For a consideration other than cash</u>	<u>Share Capital / Allottees Particulars</u>	<u>List of Shareholders after the allotment</u>	<u>Summary of Capital</u>
---------------------------------	------------------------------	--	--	---	---------------------------

**Share Capital (1)**

Currency :	<b>SINGAPORE DOLLAR (099)</b>		
Nominal Value per Share :	<b>0.10</b>		
Amount of Authorised Share Capital :	<b>200000000.00</b>		
Class of Shares :	Ordinary	Preference	Others
Amount of Issued Share Capital :	<b>102596142.50</b>	<b>0.00</b>	<b>0.00</b>
Amount of Paid-up Share Capital :	<b>102596142.50</b>	<b>0.00</b>	<b>0.00</b>

GST No. :M9-0008879-T

**RECEIPT**

Receipt No : ACR0000000933337A

Date/Time : 10/11/2004 10:29

Transaction  
No : C040511227

Agency : RCB - RCB

Application : BIZFILE PAYMENT SERVICE

Paid via : Deposit Service Account

EP Ref No :

**SINGAPORE AIRPORT TERMINAL SERVICES LIMITED**  
**20 AIRPORT BOULEVARD**  
**SATS INFLIGHT CATERING CENTRE 3**  
**SINGAPORE 819659**

---

<b>Sno Code/Description</b>	<b>Unit Price (S\$)</b>	<b>Qty</b>	<b>Amount</b>
1 Lodgment Of Return Of Allotment Of Share <b>COMPANY/BUSINESS NAME :</b> 197201770G / SINGAPORE AIRPORT TERMINAL SERVICES LIMITED	10.00	1	10.00
<hr/>			
Total (S\$) :			10.00

---

**Deposit Service Account No. : 030066**  
**Balance Amount in Deposit Account : \$ 315.00**

This is a computer-generated receipt. No signature is required.

Please print a copy of the receipt for your reference.

[HOME](#)[LOGOUT](#)

**Return of Allotment of Shares**

Submit

Please fill in the following information. Fields marked \* must be completed.

Resolution/Declaration	Shares payable in cash	For a consideration other than cash	Share Capital/Allottees Particulars	List of Shareholders after the allotment	Summary of Capital
------------------------	---------------------------	---	---	---	-----------------------

**Record saved successfully.****Company Type**

Please click on appropriate button :

- company is listed on the securities exchange  
 company is an unlisted public company  
 company is a private company

**Power under Section 161 of the Companies Act \***

The directors have obtained the approval of the company in  Yes  No general meeting to issue shares.

**Resolution Made**

\* You are only required to fill in this section if the directors are not given the power under Section 161 of the Companies Act to issue shares.

Registration No. : **197201770G**Company Name : **SINGAPORE AIRPORT TERMINAL SERVICES LIMITED**

Nature of Meeting : \* Directors

Place of Meeting : \*

Date of Meeting : \* (dd/mm/yyyy)

Resolution Type : \* Director's

Description : \*  
(max 2000 characters)Attachment : \*  
(copy of resolution)**Note :**

Uploaded file name will be changed by suffixing time-stamp with the actual file name as

**filenameyyyyMMddmmsstt**

Browse...

(Click 'Browse' to select file for attachment)

**Persons signing the resolution**

Please indicate the directors/ secretaries who signed the resolution :

- S0036442H / OW CHIN HOCK
- S0070715E / NG KEE CHOE
- S0234645A / CHEW CHOON SENG
- S1001765C / BARRY HENRY PATRICK DESKER
- S1069567H / TAN JIAK NGEE MICHAEL
- S1673157I / YIP WAI PING ANNABELLE
- S1852301I / HONG HAI @ HUANG HAI
- S2163476Z / CHENG WAI WING EDMUND
- S2580327B / RICHARD CHARLES HELFER

Please enter names of other corporate representatives who signed the resolution, if applicable :

**Declaration**

I, LIM HONG ENG SUSANNA, Professional body/service bureau, declare the information which has been submitted herein to be true to the best of my knowledge.

**Return of Allotment of Shares****Submit**

Please fill in the following information. Fields marked \* must be completed.

<u>Resolution / Declaration</u>	<u>Share payable in cash</u>	<u>For a consideration other than cash</u>	<u>Share Capital / Allottees Particulars</u>	<u>List of Shareholders after the Allotment</u>	<u>Summary of Capital</u>
---------------------------------	------------------------------	--	--	---	---------------------------

**Authorised Capital**

	<u>Amount</u>	<u>Nominal Value per Share</u>	<u>Currency</u>
Authorised Capital :	<b>200000000</b>	<b>.1</b>	<b>SINGAPORE DOLLAR ( 099 )</b>

Description of discrepancy :

**Return of Allotment of Shares (Payable in cash) \***

Applicable only if share is payable in cash

<u>Class of Shares :</u>	<u>Ordinary</u>	<u>Preference</u>	<u>Others</u>
Number of shares :	<input type="text" value="2600"/>	<input type="text"/>	<input type="text"/>
Amount paid or due and payable on each share			
paid :	<input type="text" value="0.10"/>	<input type="text"/>	<input type="text"/>
due and payable :	<input type="text" value="0"/>	<input type="text"/>	<input type="text"/>
Amount of premium paid or payable on each share :	<input type="text" value="1.50"/>	<input type="text"/>	<input type="text"/>

**Save****Delete Issued Share****Reset****Back**



**Return of Allotment of Shares**

Submit

Please fill in the following information. Fields marked \* must be completed.

<u>Resolution / Declaration</u>	<u>Share payable in cash</u>	<u>For a consideration other than cash</u>	<u>Share Capital / Allottees Particulars</u>	<u>List of Shareholders after the allotment</u>	<u>Summary of Capital</u>
---------------------------------	------------------------------	--	--	---	---------------------------

**Particulars of Allottee**

Please indicate whether the allottee is an Individual : \*

- Allottee is an Individual  
 Allottee is NOT an Individual

If Allottee is an Individual :

Shareholder Category : \* **Individual**Identification No. : \*  Retrieve DetailsIdentification Type : \* Name : \* Nationality : \* Mobile No : Occupation : Email Address : 
 Address Type : \*  
 Local  
 Foreign

Local Address (\* if Address Type is Local Address)

Postal Code :  Retrieve AddressBlock/House No. : Street Name : Unit : #  - Building/Estate Name : 

Foreign Address (\* if Address Type is Foreign Address)

Address : 

If Allottee is NOT an Individual :

Shareholder Category : \*  Search

Registration No. : \*

198003912M

Retrieve Details

Name :

THE CENTRAL DEPOSITORY (PTE) LIMITED

Address Type :

Local

Local Address (\* if Address Type is Local Address)

Postal Code : **068804**

Block/House No. : **2**

Street Name : **SHENTON WAY**

Unit : # **19 - 00**

Building/Estate Name : **SGX CENTRE I**

Foreign Address (\* if Address Type is Foreign Address)

Address :

**Details of Shares Allotted** \* Please read instructions carefully before entering.

Note : If any share or shares is/are co-owned by 2 or more persons, please assign an alphabet e.g. A to denote the Group and enter the same in the box. Enter the same alphabet in the box for every allottee in the same group. Skip this box if share(s) are owned by only one person.

Group of Share that is co-owned:  
(Share Group)

If share(s) is/are co-owned, only one allottee is to enter details in (a), (b), (c), (d) and (e). Enter "0" (zero) for subsequent allottees in box (b) and leave blank for rest of the items.

a) Nominal Value per Share :

0.10

b) No. of shares allotted :

2600

c) Class of shares allotted :

Ordinary

d) Currency :

SINGAPORE DOLLAR (099)

e) Date of allotment :

05/11/2004 (dd/mm/yyyy)

Save

Reset

Back

**Return of Allotment of Shares**[Submit](#)

Please fill in the following information. Fields marked \* must be completed.

<b>Resolution / Declaration</b>	<b>Share payable in cash</b>	<b>For a consideration other than cash</b>	<b>Share Capital / Allottees Particulars</b>	<b>List of Shareholders after Allotment</b>	<b>Summary of Capital</b>
-------------------------------------	----------------------------------	--	--	---	-------------------------------

**List of Allottees and their particulars****Identification****No./Registration Name  
No.****Shareholder Category**

198003912M	THE CENTRAL DEPOSITORY (PTE) LIMITED	Company / Foreign Branch
------------	---	--------------------------

If No. of shareholders exceeds 50, total No. of issued shares held by the remaining shareholders are :

<b>No. of Shares</b>	<b>Ordinary</b>	<b>Preference</b>	<b>Others</b>
	0	0	0

**Return of Allotment of Shares**

Submit

Please fill in the following information. Fields marked \* must be completed.

<u>Resolution / Declaration</u>	<u>Share payable in cash</u>	<u>For a consideration other than cash</u>	<u>Share Capital / Allottees Particulars</u>	<u>List of Shareholders after the allotment</u>	<u>Summary of Capital</u>
---------------------------------	------------------------------	--	--	---	---------------------------

**Share Capital (1)**Currency : **SINGAPORE DOLLAR (099)**Nominal Value per Share : **0.10**Amount of Authorised Share Capital : **200000000.00**

Class of Shares :                      Ordinary                      Preference                      Others

Amount of Issued Share Capital : **102594842.50 0.00 0.00**Amount of Paid-up Share Capital : **102594842.50 0.00 0.00**

GST No. :M9-0008879-T

**RECEIPT**

Receipt No : ACR0000000933325A

Date/Time : 10/11/2004 10:23

Transaction  
No : C040511209

Agency : RCB - RCB

Application : BIZFILE PAYMENT SERVICE

Paid via : Deposit Service Account

EP Ref No :

**SINGAPORE AIRPORT TERMINAL SERVICES LIMITED  
20 AIRPORT BOULEVARD  
SATS INFLIGHT CATERING CENTRE 3  
SINGAPORE 819659**

---

<b>Sno Code/Description</b>	<b>Unit Price (S\$)</b>	<b>Qty</b>	<b>Amount</b>
1 Lodgment Of Return Of Allotment Of Share <b>COMPANY/BUSINESS NAME :</b> 197201770G / SINGAPORE AIRPORT TERMINAL SERVICES LIMITED	10.00	1	10.00
<hr/>			
Total (S\$) :			10.00

---

**Deposit Service Account No. : 030066**  
**Balance Amount in Deposit Account : \$ 325.00**

This is a computer-generated receipt. No signature is required.

Please print a copy of the receipt for your reference.

<b>HOME</b>
-------------

<b>LOGOUT</b>
---------------

**Return of Allotment of Shares**

Submit

Please fill in the following information. Fields marked \* must be completed.

Resolution/Declaration	Shares payable in cash	For a consideration other than cash	Share Capital/Allottees Particulars	List of Shareholders after the allotment	Summary of Capital
------------------------	---------------------------	---	---	---	-----------------------

**Company Type**

Please click on appropriate button :

- company is listed on the securities exchange  
 company is an unlisted public company  
 company is a private company

**Power under Section 161 of the Companies Act \***

The directors have obtained the approval of the company in  Yes  No general meeting to issue shares.

**Resolution Made**

\* You are only required to fill in this section if the directors are not given the power under Section 161 of the Companies Act to issue shares.

Registration No. : **197201770G**Company Name : **SINGAPORE AIRPORT TERMINAL SERVICES LIMITED**

Nature of Meeting : \* Directors

Place of Meeting : \*

Date of Meeting : \* (dd/mm/yyyy)

Resolution Type : \* Director's

Description : \*  
(max 2000 characters)Attachment : \*  
(copy of resolution)**Note :**

Uploaded file name will be changed by suffixing time-stamp with the actual file name as

filenameyyyyMMddmmsstt

Maximum File Size : 2048 KB

**Persons signing the resolution**

Please indicate the directors/ secretaries who signed the resolution :

- S0036442H / OW CHIN HOCK
- S0070715E / NG KEE CHOE
- S0234645A / CHEW CHOON SENG
- S1001765C / BARRY HENRY PATRICK DESKER
- S1069567H / TAN JIAK NGEE MICHAEL
- S1673157I / YIP WAI PING ANNABELLE
- S1852301I / HONG HAI @ HUANG HAI
- S2163476Z / CHENG WAI WING EDMUND
- S2580327B / RICHARD CHARLES HELFER

Please enter names of other corporate representatives who signed the resolution, if applicable :

**Declaration**

I, LIM HONG ENG SUSANNA, Professional body/service bureau, declare the information which has been submitted herein to be true to the best of my knowledge.

**Return of Allotment of Shares**

Submit

Please fill in the following information. Fields marked \* must be completed.

Resolution / Declaration	Share payable in cash	For a consideration other than cash	Share Capital / Allottees Particulars	List of Shareholders after the Allotment	Summary of Capital
--------------------------	-----------------------	-------------------------------------	---------------------------------------	--	--------------------

**Authorised Capital**

	Amount	Nominal Value per Share	Currency
Authorised Capital :	<b>20000000</b>	<b>.1</b>	<b>SINGAPORE DOLLAR ( 099 )</b>

Description of discrepancy :

**Return of Allotment of Shares (Payable in cash) \***

Applicable only if share is payable in cash

Class of Shares :	Ordinary	Preference	Others
Number of shares :	3200 /		
Amount paid or due and payable on each share			
paid :	0.10 /		
due and payable :	0		
Amount of premium paid or payable on each share :	1.14 /		

Save

Delete Issued Share

Reset

Back



**Return of Allotment of Shares**

Submit

Please fill in the following information. Fields marked \* must be completed.

Resolution / Declaration	Share payable in cash	For a consideration other than cash	Share Capital / Allottees Particulars	List of Shareholders after the allotment	Summary of Capital
-----------------------------	--------------------------	---	---	---	-----------------------

**Particulars of Allottee**

Please indicate whether the allottee is an Individual : \*

- Allottee is an Individual  
 Allottee is NOT an Individual

If Allottee is an Individual :

Shareholder Category : \* **Individual**Identification No. : \*  Retrieve DetailsIdentification Type : \*  ▼Name : \* Nationality : \*  ▼Mobile No : Occupation : Email Address : Address Type : \*  
 Local  
 Foreign

Local Address (\* if Address Type is Local Address)

Postal Code :  Retrieve AddressBlock/House No. :  ▼

Street Name :

Unit : #  - 

Building/Estate Name :

Foreign Address (\* if Address Type is Foreign Address)

Address : 

If Allottee is NOT an Individual :

Shareholder Category : \*  Search

Registration No. : \*

198003912M

Retrieve Details

Name :

**THE CENTRAL DEPOSITORY (PTE) LIMITED**

Address Type :

**Local**

Local Address (\* if Address Type is Local Address)

Postal Code : **068804**

Block/House No. : **2**

Street Name : **SHENTON WAY**

Unit : # **19 - 00**

Building/Estate Name : **SGX CENTRE I**

Foreign Address (\* if Address Type is Foreign Address)

Address :

**Details of Shares Allotted** \* Please read instructions carefully before entering.

Note : If any share or shares is/are co-owned by 2 or more persons, please assign an alphabet e.g. A to denote the Group and enter the same in the box. Enter the same alphabet in the box for every allottee in the same group. Skip this box if share(s) are owned by only one person.

Group of Share that is co-owned:  
(Share Group)

If share(s) is/are co-owned, only one allottee is to enter details in (a), (b), (c), (d) and (e). Enter "0" (zero) for subsequent allottees in box (b) and leave blank for rest of the items.

a) Nominal Value per Share :

0.10

b) No. of shares allotted :

3200

c) Class of shares allotted :

Ordinary

d) Currency :

SINGAPORE DOLLAR (099)

e) Date of allotment :

05/11/2004 (dd/mm/yyyy)

Save Reset Back

**Return of Allotment of Shares**[Submit](#)

Please fill in the following information. Fields marked \* must be completed.

<b>Resolution / Declaration</b>	<b>Share payable in cash</b>	<b>For a consideration other than cash</b>	<b>Share Capital / Allottees Particulars</b>	<b>List of Shareholders after Allotment</b>	<b>Summary of Capital</b>
-------------------------------------	----------------------------------	--	--	---	-------------------------------

**List of Allottees and their particulars****Identification****No./Registration Name  
No.****Shareholder Category**

198003912M	THE CENTRAL DEPOSITORY (PTE) LIMITED	Company / Foreign Branch
------------	---	--------------------------

If No. of shareholders exceeds 50, total No. of issued shares held by the remaining shareholders are :

	<b>Ordinary</b>	<b>Preference</b>	<b>Others</b>
<b>No. of Shares</b>	<b>0</b>	<b>0</b>	<b>0</b>

**Return of Allotment of Shares****Submit**

Please fill in the following information. Fields marked \* must be completed.

<u>Resolution / Declaration</u>	<u>Share payable in cash</u>	<u>For a consideration other than cash</u>	<u>Share Capital / Allottees Particulars</u>	<u>List of Shareholders after the allotment</u>	<u>Summary of Capital</u>
-------------------------------------	----------------------------------	--	--	---	-------------------------------

**Share Capital (1)**

Currency :	<b>SINGAPORE DOLLAR (099)</b>				
Nominal Value per Share :	<b>0.10</b>				
Amount of Authorised Share Capital :	<b>200000000.00</b>				
Class of Shares :	Ordinary	Preference	Others		
Amount of Issued Share Capital :	<b>102594582.50</b>	<b>0.00</b>	<b>0.00</b>		
Amount of Paid-up Share Capital :	<b>102594582.50</b>	<b>0.00</b>	<b>0.00</b>		

**RECEIPT**

Receipt No : ACR0000000929927A

Date/Time : 08/11/2004 10:28

Transaction  
No : C040507673

Agency : RCB - RCB

Application : BIZFILE PAYMENT SERVICE

Paid via : Deposit Service Account

EP Ref No :

**SINGAPORE AIRPORT TERMINAL SERVICES LIMITED**  
**20 AIRPORT BOULEVARD**  
**SATS INFLIGHT CATERING CENTRE 3**  
**SINGAPORE 819659**

---

<b>Sno Code/Description</b>	<b>Unit Price (S\$)</b>	<b>Qty</b>	<b>Amount</b>
1 Lodgment Of Return Of Allotment Of Share <b>COMPANY/BUSINESS NAME :</b> 197201770G / SINGAPORE AIRPORT TERMINAL SERVICES LIMITED	10.00	1	10.00
<b>Total (S\$) :</b>			<b>10.00</b>

---

**Deposit Service Account No. : 030066**  
**Balance Amount in Deposit Account : \$ 335.00**

This is a computer-generated receipt. No signature is required.

Please print a copy of the receipt for your reference.

[HOME](#)[LOGOUT](#)

**Return of Allotment of Shares**

Submit

Please fill in the following information. Fields marked \* must be completed.

Resolution/Declaration	Shares payable in cash	For a consideration other than cash	Share Capital/Allottees Particulars	List of Shareholders after the allotment	Summary of Capital
------------------------	---------------------------	---	---	---	-----------------------

**Record saved successfully.****Company Type**

Please click on appropriate button :

- company is listed on the securities exchange
- company is an unlisted public company
- company is a private company

**Power under Section 161 of the Companies Act \***

The directors have obtained  
the approval of the company in  Yes  
general meeting to issue  No  
shares.

**Resolution Made**

\* You are only required to fill in this section if the directors are not given the power under Section 161 of the Companies Act to issue shares.

Registration No. : **197201770G**Company Name : **SINGAPORE AIRPORT TERMINAL SERVICES LIMITED**

Nature of Meeting : \* Directors

Place of Meeting : \*

Date of Meeting : \* (dd/mm/yyyy)

Resolution Type : \* Director's

Description : \*  
(max 2000 characters)Attachment : \*  
(copy of resolution)**Note :**

Uploaded file name will be  
changed by suffixing time-  
stamp with the actual file  
name as

filenameyyyMMddmmsstt

Browse...

(Click 'Browse' to select file for attachment)

**Persons signing the resolution**

Please indicate the directors/ secretaries who signed the resolution :

- S0036442H / OW CHIN HOCK
- S0070715E / NG KEE CHOE
- S0234645A / CHEW CHOON SENG
- S1001765C / BARRY HENRY PATRICK DESKER
- S1069567H / TAN JIAK NGEE MICHAEL
- S1673157I / YIP WAI PING ANNABELLE
- S1852301I / HONG HAI @ HUANG HAI
- S2163476Z / CHENG WAI WING EDMUND
- S2580327B / RICHARD CHARLES HELFER

Please enter names of other corporate representatives who signed the resolution, if applicable :

**Declaration**

I, LIM HONG ENG SUSANNA, Professional body/service bureau, declare the information which has been submitted herein to be true to the best of my knowledge.

**Return of Allotment of Shares**

[Submit](#)

Please fill in the following information. Fields marked \* must be completed.

Resolution / Declaration	Share payable in cash	For a consideration other than cash	Share Capital / Allottees Particulars	List of Shareholders after the Allotment	Summary of Capital
--------------------------	-----------------------	-------------------------------------	---------------------------------------	--	--------------------

**Authorised Capital**

	Amount	Nominal Value per Share	Currency
Authorised Capital :	<b>20000000</b>	<b>.1</b>	<b>SINGAPORE DOLLAR ( 099 )</b>

Description of discrepancy :

**Return of Allotment of Shares (Payable in cash) \***

Applicable only if share is payable in cash

Class of Shares :	Ordinary	Preference	Others
Number of shares :	<input type="text" value="20800"/>	<input type="text"/>	<input type="text"/>
Amount paid or due and payable on each share			
paid :	<input type="text" value="0.10"/>	<input type="text"/>	<input type="text"/>
due and payable :	<input type="text" value="0"/>	<input type="text"/>	<input type="text"/>
Amount of premium paid or payable on each share :	<input type="text" value="1.50"/>	<input type="text"/>	<input type="text"/>

[Save](#) [Delete Issued Share](#) [Reset](#) [Back](#)



**Return of Allotment of Shares****Submit**

Please fill in the following information. Fields marked \* must be completed.

<u>Resolution / Declaration</u>	<u>Share payable in cash</u>	<u>For a consideration other than cash</u>	<u>Share Capital / Allottees Particulars</u>	<u>List of Shareholders after the allotment</u>	<u>Summary of Capital</u>
---------------------------------	------------------------------	--	--	---	---------------------------

**Particulars of Allottee****Please indicate whether the allottee is an Individual : \***

- Allottee is an Individual  
 Allottee is NOT an Individual

**If Allottee is an Individual :**Shareholder Category : \* **Individual**Identification No. : \*  **Retrieve Details**Identification Type : \*  Name : \* Nationality : \*  Mobile No : Occupation : Email Address : Address Type : \*  
 Local  
 Foreign

Local Address (\* if Address Type is Local Address)

Postal Code :  **Retrieve Address**Block/House No. :  Street Name : Unit : #  - Building/Estate Name : 

Foreign Address (\* if Address Type is Foreign Address)

Address : **If Allottee is NOT an Individual :**Shareholder Category : \*   **Search**

Registration No. : \*

198003912M

Retrieve Details

Name :

**THE CENTRAL DEPOSITORY (PTE) LIMITED**

Address Type :

**Local**

Local Address (\* if Address Type is Local Address)

Postal Code : **068804**

Block/House No. : **2**

Street Name : **SHENTON WAY**

Unit : # **19 - 00**

Building/Estate Name : **SGX CENTRE I**

Foreign Address (\* if Address Type is Foreign Address)

Address :

**Details of Shares Allotted** \* Please read instructions carefully before entering.

Note : If any share or shares is/are co-owned by 2 or more persons, please assign an alphabet e.g. A to denote the Group and enter the same in the box. Enter the same alphabet in the box for every allottee in the same group. Skip this box if share(s) are owned by only one person.

Group of Share that is co-owned:  
(Share Group)

If share(s) is/are co-owned, only one allottee is to enter details in (a), (b), (c), (d) and (e). Enter "0" (zero) for subsequent allottees in box (b) and leave blank for rest of the items.

a) Nominal Value per Share :

0.10

b) No. of shares allotted :

20800

c) Class of shares allotted :

Ordinary

d) Currency :

SINGAPORE DOLLAR (099)

e) Date of allotment :

04/11/2004 (dd/mm/yyyy)

Save

Reset

Back

**Return of Allotment of Shares****Submit**

Please fill in the following information. Fields marked \* must be completed.

Resolution / Declaration	Share payable in cash	For a consideration other than cash	Share Capital / Allottees Particulars	List of Shareholders after Allotment	Summary of Capital
-----------------------------	--------------------------	---	---	--	-----------------------

**List of Allottees and their particulars****Identification****No./Registration Name  
No.****Shareholder Category**

198003912M	THE CENTRAL DEPOSITORY (PTE) LIMITED	Company / Foreign Branch
------------	---	--------------------------

If No. of shareholders exceeds 50, total No. of issued shares held by the remaining shareholders are :

	<b>Ordinary</b>	<b>Preference</b>	<b>Others</b>
<b>No. of Shares</b>	<b>0</b>	<b>0</b>	<b>0</b>

**Return of Allotment of Shares****Submit**

Please fill in the following information. Fields marked \* must be completed.

<u>Resolution / Declaration</u>	<u>Share payable in cash</u>	<u>For a consideration other than cash</u>	<u>Share Capital / Allottees Particulars</u>	<u>List of Shareholders after the allotment</u>	<u>Summary of Capital</u>
<b>Share Capital (1)</b>					
Currency :	<b>SINGAPORE DOLLAR (099)</b>				
Nominal Value per Share :	<b>0.10</b>				
Amount of Authorised Share Capital :	<b>200000000.00</b>				
Class of Shares :	Ordinary	Preference	Others		
Amount of Issued Share Capital :	<b>102594262.50</b>	<b>0.00</b>	<b>0.00</b>		
Amount of Paid-up Share Capital :	<b>102594262.50</b>	<b>0.00</b>	<b>0.00</b>		

GST No. :M9-0008879-T

**RECEIPT**

Receipt No : ACR0000000929906A

Date/Time : 08/11/2004 10:23

Transaction  
No : C040507653

Agency : RCB - RCB

Application : BIZFILE PAYMENT SERVICE

Paid via : Deposit Service Account

EP Ref No :

**SINGAPORE AIRPORT TERMINAL SERVICES LIMITED  
20 AIRPORT BOULEVARD  
SATS INFLIGHT CATERING CENTRE 3  
SINGAPORE 819659**

<b>Sno Code/Description</b>	<b>Unit Price (S\$)</b>	<b>Qty</b>	<b>Amount</b>
1 Lodgment Of Return Of Allotment Of Share <b>COMPANY/BUSINESS NAME :</b> 197201770G / SINGAPORE AIRPORT TERMINAL SERVICES LIMITED	10.00	1	10.00
<b>Total (S\$) :</b>			<b>10.00</b>

**Deposit Service Account No. : 030066  
Balance Amount in Deposit Account : \$ 345.00**

This is a computer-generated receipt. No signature is required.

Please print a copy of the receipt for your reference.

[HOME](#)[LOGOUT](#)

**Return of Allotment of Shares**

Submit

Please fill in the following information. Fields marked \* must be completed.

Resolution/Declaration	Shares payable in cash	For a consideration other than cash	Share Capital/Allottees Particulars	List of Shareholders after the allotment	Summary of Capital
------------------------	---------------------------	---	---	---	-----------------------

**Record saved successfully.****Company Type**

Please click on appropriate button :

- company is listed on the securities exchange
- company is an unlisted public company
- company is a private company

**Power under Section 161 of the Companies Act \***

The directors have obtained  
the approval of the company in  Yes  
general meeting to issue  No  
shares.

**Resolution Made**

\* You are only required to fill in this section if the directors are not given the power under Section 161 of the Companies Act to issue shares.

Registration No. : **197201770G**Company Name : **SINGAPORE AIRPORT TERMINAL SERVICES LIMITED**

Nature of Meeting : \* Directors

Place of Meeting : \*

Date of Meeting : \* (dd/mm/yyyy)

Resolution Type : \* Director's

Description : \*  
(max 2000 characters)Attachment : \*  
(copy of resolution)**Note :**

Uploaded file name will be  
changed by suffixing time-  
stamp with the actual file  
name as

filenameyyyyMMddmmsstt

Browse...

(Click 'Browse' to select file for attachment)

**Persons signing the resolution**

Please indicate the directors/ secretaries who signed the resolution :

- S0036442H / OW CHIN HOCK
- S0070715E / NG KEE CHOE
- S0234645A / CHEW CHOON SENG
- S1001765C / BARRY HENRY PATRICK DESKER
- S1069567H / TAN JIAK NGEE MICHAEL
- S1673157I / YIP WAI PING ANNABELLE
- S1852301I / HONG HAI @ HUANG HAI
- S2163476Z / CHENG WAI WING EDMUND
- S2580327B / RICHARD CHARLES HELFER

Please enter names of other corporate representatives who signed the resolution, if applicable :

**Declaration**

I, LIM HONG ENG SUSANNA, Professional body/service bureau, declare the information which has been submitted herein to be true to the best of my knowledge.

**Return of Allotment of Shares**

Submit

Please fill in the following information. Fields marked \* must be completed.

Resolution / Declaration	Share payable in cash	For a consideration other than cash	Share Capital / Allottees Particulars	List of Shareholders after the Allotment	Summary of Capital
--------------------------	-----------------------	-------------------------------------	---------------------------------------	--	--------------------

**Authorised Capital**

	Amount	Nominal Value per Share	Currency
Authorised Capital :	<b>20000000</b>	<b>.1</b>	<b>SINGAPORE DOLLAR ( 099 )</b>

Description of discrepancy :

**Return of Allotment of Shares (Payable in cash) \***

Applicable only if share is payable in cash

Class of Shares :	Ordinary	Preference	Others
Number of shares :	15600		
Amount paid or due and payable on each share			
paid :	0.10		
due and payable :	0		
Amount of premium paid or payable on each share :	1.14		

Save      Delete Issued Share      Reset      Back



**Return of Allotment of Shares**

Submit

Please fill in the following information. Fields marked \* must be completed.

Resolution / Declaration	Share payable in cash	For a consideration other than cash	Share Capital / Allottees Particulars	List of Shareholders after the allotment	Summary of Capital
-----------------------------	--------------------------	---	---	---	-----------------------

**Particulars of Allottee**

Please indicate whether the allottee is an Individual : \*

- Allottee is an Individual  
 Allottee is NOT an Individual

If Allottee is an Individual :

Shareholder Category : \* **Individual**

Identification No. : \*

Retrieve Details

Identification Type : \*

NRIC 

Name : \*

Nationality : \*

Mobile No :

Occupation :

Email Address :

Address Type : \*

- Local  
 Foreign

Local Address (\* if Address Type is Local Address)

Postal Code :

Retrieve Address

Block/House No. :

Street Name :

Unit : #

 - 

Building/Estate Name :

Foreign Address (\* if Address Type is Foreign Address)

Address :

If Allottee is NOT an Individual :

Shareholder Category : \*

Company / Foreign Branch

Search

Name : THE CENTRAL DEPOSITORY (PTE) LIMITED

Address Type : Local

Local Address (\* if Address Type is Local Address)

Postal Code : 068804

Block/House No. : 2

Street Name : SHENTON WAY

Unit : # 19 - 00

Building/Estate Name : SGX CENTRE I

Foreign Address (\* if Address Type is Foreign Address)

Address :

**Details of Shares Allotted** \* Please read instructions carefully before entering.

Note : If any share or shares is/are co-owned by 2 or more persons, please assign an alphabet e.g. A to denote the Group and enter the same in the box. Enter the same alphabet in the box for every allottee in the same group. Skip this box if share(s) are owned by only one person.

Group of Share that is co-owned:   
(Share Group)

If share(s) is/are co-owned, only one allottee is to enter details in (a), (b), (c), (d) and (e). Enter "0" (zero) for subsequent allottees in box (b) and leave blank for rest of the items.

a) Nominal Value per Share :

b) No. of shares allotted :

c) Class of shares allotted :

d) Currency :

e) Date of allotment :  (dd/mm/yyyy)

**Return of Allotment of Shares****Submit**

Please fill in the following information. Fields marked \* must be completed.

<b>Resolution / Declaration</b>	<b>Share payable in cash</b>	<b>For a consideration other than cash</b>	<b>Share Capital / Allottees Particulars</b>	<b>List of Shareholders after Allotment</b>	<b>Summary of Capital</b>
-------------------------------------	----------------------------------	--	--	---	-------------------------------

**List of Allottees and their particulars****Identification****No./Registration Name  
No.****Shareholder Category**

198003912M	THE CENTRAL DEPOSITORY (PTE) LIMITED	Company / Foreign Branch
------------	---	--------------------------

If No. of shareholders exceeds 50, total No. of issued shares held by the remaining shareholders are :

<b>No. of Shares</b>	<b>Ordinary</b>	<b>Preference</b>	<b>Others</b>
	0	0	0

**Return of Allotment of Shares**

**Submit**

Please fill in the following information. Fields marked \* must be completed.

Resolution / Declaration	Share payable in cash	For a consideration other than cash	Share Capital / Allottees Particulars	List of Shareholders after the allotment	Summary of Capital
<b>Share Capital (1)</b>					
Currency :	<b>SINGAPORE DOLLAR (099)</b>				
Nominal Value per Share :	<b>0.10</b>				
Amount of Authorised Share Capital :	<b>200000000.00</b>				
Class of Shares :	Ordinary	Preference	Others		
Amount of Issued Share Capital :	<b>102592182.50</b>	<b>0.00</b>	<b>0.00</b>		
Amount of Paid-up Share Capital :	<b>102592182.50</b>	<b>0.00</b>	<b>0.00</b>		

**RECEIPT**

Receipt No : ACR0000000929887A

Date/Time : 08/11/2004 10:16

Transaction  
No : C040507632

Agency : RCB - RCB

Application : BIZFILE PAYMENT SERVICE

Paid via : Deposit Service Account

EP Ref No :

**SINGAPORE AIRPORT TERMINAL SERVICES LIMITED**  
**20 AIRPORT BOULEVARD**  
**SATS INFLIGHT CATERING CENTRE 3**  
**SINGAPORE 819659**

---

<b>Sno Code/Description</b>	<b>Unit Price (S\$)</b>	<b>Qty</b>	<b>Amount</b>
1 Lodgment Of Return Of Allotment Of Share <b>COMPANY/BUSINESS NAME :</b> 197201770G / SINGAPORE AIRPORT TERMINAL SERVICES LIMITED	10.00	1	10.00
<hr/>			
Total (S\$) :			10.00

---

**Deposit Service Account No. : 030066**  
**Balance Amount in Deposit Account : \$ 355.00**

This is a computer-generated receipt. No signature is required.

Please print a copy of the receipt for your reference.

[HOME](#)[LOGOUT](#)

**Return of Allotment of Shares**

Submit

Please fill in the following information. Fields marked \* must be completed.

Resolution/Declaration	Shares payable in cash	For a consideration other than cash	Share Capital/Allottees Particulars	List of Shareholders after the allotment	Summary of Capital
------------------------	---------------------------	---	---	---	-----------------------

**Record saved successfully.****Company Type**

Please click on appropriate button :

- company is listed on the securities exchange  
 company is an unlisted public company  
 company is a private company

**Power under Section 161 of the Companies Act \***

The directors have obtained  
the approval of the company in  Yes  
general meeting to issue  No  
shares.

**Resolution Made**

\* You are only required to fill in this section if the directors are not given the power under Section 161 of the Companies Act to issue shares.

Registration No. : **197201770G**Company Name : **SINGAPORE AIRPORT TERMINAL SERVICES LIMITED**

Nature of Meeting : \* Directors

Place of Meeting : \*

Date of Meeting : \* (dd/mm/yyyy)

Resolution Type : \* Director's

Description : \*  
(max 2000 characters)Attachment : \*  
(copy of resolution)**Note :**

Uploaded file name will be  
changed by suffixing time-  
stamp with the actual file  
name as

filenameyyyyMMddmmsstt

Browse...

(Click 'Browse' to select file for attachment)

**Persons signing the resolution**

Please indicate the directors/ secretaries who signed the resolution :

- S0036442H / OW CHIN HOCK
- S0070715E / NG KEE CHOE
- S0234645A / CHEW CHOON SENG
- S1001765C / BARRY HENRY PATRICK DESKER
- S1069567H / TAN JIAK NGEE MICHAEL
- S1673157I / YIP WAI PING ANNABELLE
- S1852301I / HONG HAI @ HUANG HAI
- S2163476Z / CHENG WAI WING EDMUND
- S2580327B / RICHARD CHARLES HELFER

Please enter names of other corporate representatives who signed the resolution, if applicable :

**Declaration**

I, LIM HONG ENG SUSANNA, Professional body/service bureau, declare the information which has been submitted herein to be true to the best of my knowledge.

**Return of Allotment of Shares****Submit**

Please fill in the following information. Fields marked \* must be completed.

<b>Resolution / Declaration</b>	<b>Share payable in cash</b>	<b>For a consideration other than cash</b>	<b>Share Capital / Allottees Particulars</b>	<b>List of Shareholders after the Allotment</b>	<b>Summary of Capital</b>
---------------------------------	------------------------------	--	--	---	---------------------------

**Authorised Capital**

	<b>Amount</b>	<b>Nominal Value per Share</b>	<b>Currency</b>
Authorised Capital :	<b>20000000</b>	<b>.1</b>	<b>SINGAPORE DOLLAR ( 099 )</b>

Description of discrepancy :

**Return of Allotment of Shares (Payable in cash) \***

Applicable only if share is payable in cash

<b>Class of Shares :</b>	<b>Ordinary</b>	<b>Preference</b>	<b>Others</b>
Number of shares :	<input type="text" value="6500"/>	<input type="text"/>	<input type="text"/>
Amount paid or due and payable on each share			
paid :	<input type="text" value="0.10"/>	<input type="text"/>	<input type="text"/>
due and payable :	<input type="text" value="0"/>	<input type="text"/>	<input type="text"/>
Amount of premium paid or payable on each share :	<input type="text" value="1.70"/>	<input type="text"/>	<input type="text"/>

<b>Save</b>	<b>Delete Issued Share</b>	<b>Reset</b>	<b>Back</b>
-------------	----------------------------	--------------	-------------



**Return of Allotment of Shares**

Submit

Please fill in the following information. Fields marked \* must be completed.

Resolution / Declaration	Share payable in cash	For a consideration other than cash	Share Capital / Allottees Particulars	List of Shareholders after the allotment	Summary of Capital
-----------------------------	--------------------------	---	---	---	-----------------------

**Particulars of Allottee**

Please indicate whether the allottee is an Individual : \*

- Allottee is an Individual  
 Allottee is NOT an Individual

If Allottee is an Individual :

Shareholder Category : \* **Individual**

Identification No. : \*

Retrieve Details

Identification Type : \*

NRIC 

Name : \*

Nationality : \*

Mobile No :

Occupation :

Email Address :

Address Type : \*

- Local  
 Foreign

Local Address (\* if Address Type is Local Address)

Postal Code :

Retrieve Address

Block/House No. :

Street Name :

Unit : #

 - 

Building/Estate Name :

Foreign Address (\* if Address Type is Foreign Address)

Address :

If Allottee is NOT an Individual :

Shareholder Category : \*

Company / Foreign Branch 

Search

Registration No. : \*

198003912M

Retrieve Details

Name : **THE CENTRAL DEPOSITORY (PTE) LIMITED**

Address Type : **Local**

Local Address (\* if Address Type is Local Address)

Postal Code : **068804**

Block/House No. : **2**

Street Name : **SHENTON WAY**

Unit : # **19 - 00**

Building/Estate Name : **SGX CENTRE I**

Foreign Address (\* if Address Type is Foreign Address)

Address :

**Details of Shares Allotted** \* Please read instructions carefully before entering.

Note : If any share or shares is/are co-owned by 2 or more persons, please assign an alphabet e.g. A to denote the Group and enter the same in the box. Enter the same alphabet in the box for every allottee in the same group. Skip this box if share(s) are owned by only one person.

Group of Share that is co-owned:  
(Share Group)

If share(s) is/are co-owned, only one allottee is to enter details in (a), (b), (c), (d) and (e). Enter "0" (zero) for subsequent allottees in box (b) and leave blank for rest of the items:

a) Nominal Value per Share :

b) No. of shares allotted :

c) Class of shares allotted :

d) Currency :

e) Date of allotment :  (dd/mm/yyyy)

**Return of Allotment of Shares****Submit**

Please fill in the following information. Fields marked \* must be completed.

Resolution / Declaration	Share payable in cash	For a consideration other than cash	Share Capital / Allottees Particulars	List of Shareholders after Allotment	Summary of Capital
-----------------------------	--------------------------	---	---	--	-----------------------

**List of Allottees and their particulars****Identification****No./Registration Name  
No.****Shareholder Category**

198003912M	THE CENTRAL DEPOSITORY (PTE) LIMITED	Company / Foreign Branch
------------	---	--------------------------

If No. of shareholders exceeds 50, total No. of issued shares held by the remaining shareholders are :

<b>No. of Shares</b>	<b>Ordinary</b>	<b>Preference</b>	<b>Others</b>
	0	0	0

**Return of Allotment of Shares****Submit**

Please fill in the following information. Fields marked \* must be completed.

<u>Resolution / Declaration</u>	<u>Share payable in cash</u>	<u>For a consideration other than cash</u>	<u>Share Capital / Allottees Particulars</u>	<u>List of Shareholders after the allotment</u>	<u>Summary of Capital</u>
<b>Share Capital (1)</b>					
Currency :	<b>SINGAPORE DOLLAR (099)</b>				
Nominal Value per Share :	<b>0.10</b>				
Amount of Authorised Share Capital :	<b>200000000.00</b>				
Class of Shares :	Ordinary	Preference	Others		
Amount of Issued Share Capital :	<b>102590622.50</b>	<b>0.00</b>	<b>0.00</b>		
Amount of Paid-up Share Capital :	<b>102590622.50</b>	<b>0.00</b>	<b>0.00</b>		



GST No. :M9-0008879-T

**RECEIPT**

Receipt No : ACR0000000927848A

Date/Time : 05/11/2004 09:39

Transaction No : C040505417

Agency : RCB - RCB

Application : BIZFILE PAYMENT SERVICE

Paid via : Deposit Service Account

EP Ref No :

**SINGAPORE AIRPORT TERMINAL SERVICES LIMITED  
20 AIRPORT BOULEVARD  
SATS INFLIGHT CATERING CENTRE 3  
SINGAPORE 819659**

Sno	Code/Description	Unit Price (S\$)	Qty	Amount
1	Lodgment Of Return Of Allotment Of Share <b>COMPANY/BUSINESS NAME :</b> 197201770G / SINGAPORE AIRPORT TERMINAL SERVICES LIMITED	10.00	1	10.00
Total (S\$) :				10.00

**Deposit Service Account No. : 030066**  
**Balance Amount in Deposit Account : \$ 365.00**

This is a computer-generated receipt. No signature is required.

Please print a copy of the receipt for your reference.

[HOME](#)   [LOGOUT](#)

**Return of Allotment of Shares****Submit**

Please fill in the following information. Fields marked \* must be completed.

Resolution/Declaration	Shares payable in cash	For a consideration other than cash	Share Capital/Allottees Particulars	List of Shareholders after the allotment	Summary of Capital
------------------------	---------------------------	---	---	---	-----------------------

**Record saved successfully.****Company Type**

Please click on appropriate button :

- company is listed on the securities exchange  
 company is an unlisted public company  
 company is a private company

**Power under Section 161 of the Companies Act \***

The directors have obtained the approval of the company in general meeting to issue shares.

Yes  
 No

**Resolution Made**

\* You are only required to fill in this section if the directors are not given the power under Section 161 of the Companies Act to issue shares.

Registration No. : **197201770G**Company Name : **SINGAPORE AIRPORT TERMINAL SERVICES LIMITED**Nature of Meeting : \* **Directors**

Place of Meeting : \*

Date of Meeting : \* (dd/mm/yyyy)

Resolution Type : \* **Director's**Description : \*  
(max 2000 characters)Attachment : \*  
(copy of resolution)**Note :**

Uploaded file name will be changed by suffixing time-stamp with the actual file name as

**filenameyyyyMMddmmsstt****Browse...**

(Click 'Browse' to select file for attachment)

**Persons signing the resolution**

Please indicate the directors/ secretaries who signed the resolution :

- S0036442H / OW CHIN HOCK
- S0070715E / NG KEE CHOE
- S0234645A / CHEW CHOON SENG
- S1001765C / BARRY HENRY PATRICK DESKER
- S1069567H / TAN JIAK NGEE MICHAEL
- S1673157I / YIP WAI PING ANNABELLE
- S1852301I / HONG HAI @ HUANG HAI
- S2163476Z / CHENG WAI WING EDMUND
- S2580327B / RICHARD CHARLES HELFER

Please enter names of other corporate representatives who signed the resolution, if applicable :

**Declaration**

I, LIM HONG ENG SUSANNA, Professional body/service bureau, declare the information which has been submitted herein to be true to the best of my knowledge.

**Return of Allotment of Shares**

[Submit](#)

Please fill in the following information. Fields marked \* must be completed.

<u>Resolution / Declaration</u>	<u>Share payable in cash</u>	<u>For a consideration other than cash</u>	<u>Share Capital / Allottees Particulars</u>	<u>List of Shareholders after the Allotment</u>	<u>Summary of Capital</u>
---------------------------------	------------------------------	--	--	---	---------------------------

**Authorised Capital**

	<u>Amount</u>	<u>Nominal Value per Share</u>	<u>Currency</u>
Authorised Capital :	<b>200000000</b>	<b>.1</b>	<b>SINGAPORE DOLLAR ( 099 )</b>

Description of discrepancy :

**Return of Allotment of Shares (Payable in cash) \***

Applicable only if share is payable in cash

<u>Class of Shares :</u>	<u>Ordinary</u>	<u>Preference</u>	<u>Others</u>
Number of shares :	<input type="text" value="7800"/>	<input type="text"/>	<input type="text"/>
Amount paid or due and payable on each share			
paid :	<input type="text" value="0.10"/>	<input type="text"/>	<input type="text"/>
due and payable :	<input type="text" value="0"/>	<input type="text"/>	<input type="text"/>
Amount of premium paid or payable on each share :	<input type="text" value="1.50"/>	<input type="text"/>	<input type="text"/>

[Save](#)   [Delete Issued Share](#)   [Reset](#)   [Back](#)



**Return of Allotment of Shares**

Submit

Please fill in the following information. Fields marked \* must be completed.

Resolution / Declaration	Share payable in cash	For a consideration other than cash	Share Capital / Allottees Particulars	List of Shareholders after the allotment	Summary of Capital
--------------------------	-----------------------	-------------------------------------	---------------------------------------	--	--------------------

**Particulars of Allottee**

Please indicate whether the allottee is an Individual : \*

- Allottee is an Individual  
 Allottee is NOT an Individual

If Allottee is an Individual :

Shareholder Category : \* **Individual**

Identification No. : \*

Retrieve Details

Identification Type : \*

NRIC 

Name : \*

Nationality : \*

Mobile No :

Occupation :

Email Address :

Address Type : \*

- Local  
 Foreign

Local Address (\* if Address Type is Local Address)

Postal Code :

Retrieve Address

Block/House No. :

Street Name :

Unit : #

 - 

Building/Estate Name :

Foreign Address (\* if Address Type is Foreign Address)

Address :

If Allottee is NOT an Individual :

Shareholder Category : \*

Company / Foreign Branch 

Search

Name : THE CENTRAL DEPOSITORY (PTE) LIMITED

Address Type : Local

Local Address (\* if Address Type is Local Address)

Postal Code : 068804

Block/House No. : 2

Street Name : SHENTON WAY

Unit : # 19 - 00

Building/Estate Name : SGX CENTRE I

Foreign Address (\* if Address Type is Foreign Address)

Address :

**Details of Shares Allotted** \* Please read instructions carefully before entering.

Note : If any share or shares is/are co-owned by 2 or more persons, please assign an alphabet e.g. A to denote the Group and enter the same in the box. Enter the same alphabet in the box for every allottee in the same group. Skip this box if share(s) are owned by only one person.

Group of Share that is co-owned:   
(Share Group)

If share(s) is/are co-owned, only one allottee is to enter details in (a), (b), (c), (d) and (e). Enter "0" (zero) for subsequent allottees in box (b) and leave blank for rest of the items.

a) Nominal Value per Share :

b) No. of shares allotted :

c) Class of shares allotted :

d) Currency :

e) Date of allotment :  (dd/mm/yyyy)

**Return of Allotment of Shares**

Please fill in the following information. Fields marked \* must be completed.

Resolution / Declaration	Share payable in cash	For a consideration other than cash	Share Capital / Allottees Particulars	List of Shareholders after Allotment	Summary of Capital
-----------------------------	--------------------------	---	---	--	-----------------------

**List of Allottees and their particulars****Identification****No./Registration Name  
No.****Shareholder Category**

198003912M	THE CENTRAL DEPOSITORY (PTE) LIMITED	Company / Foreign Branch
------------	---	--------------------------

If No. of shareholders exceeds 50, total No. of issued shares held by the remaining shareholders are :

	<b>Ordinary</b>	<b>Preference</b>	<b>Others</b>
<b>No. of Shares</b>	0	0	0

**Return of Allotment of Shares****Submit**

Please fill in the following information. Fields marked \* must be completed.

<u>Resolution / Declaration</u>	<u>Share payable in cash</u>	<u>For a consideration other than cash</u>	<u>Share Capital / Allottees Particulars</u>	<u>List of Shareholders after the allotment</u>	<u>Summary of Capital</u>
---------------------------------	------------------------------	--	--	---	---------------------------

**Share Capital (1)**

Currency :	<b>SINGAPORE DOLLAR (099)</b>		
Nominal Value per Share :	<b>0.10</b>		
Amount of Authorised Share Capital :	<b>200000000.00</b>		
Class of Shares :	Ordinary	Preference	Others
Amount of Issued Share Capital :	<b>102589972.50</b>	<b>0.00</b>	<b>0.00</b>
Amount of Paid-up Share Capital :	<b>102589972.50</b>	<b>0.00</b>	<b>0.00</b>

**RECEIPT**

Receipt No : ACR0000000927838A

Date/Time : 05/11/2004 09:34

Transaction No : C040505406

Agency : RCB - RCB

Application : BIZFILE PAYMENT SERVICE

Paid via : Deposit Service Account

EP Ref No :

**SINGAPORE AIRPORT TERMINAL SERVICES LIMITED  
20 AIRPORT BOULEVARD  
SATS INFLIGHT CATERING CENTRE 3  
SINGAPORE 819659**

---

<b>Sno Code/Description</b>	<b>Unit Price (S\$)</b>	<b>Qty</b>	<b>Amount</b>
1 Lodgment Of Return Of Allotment Of Share <b>COMPANY/BUSINESS NAME :</b> 197201770G / SINGAPORE AIRPORT TERMINAL SERVICES LIMITED	10.00	1	10.00
<b>Total (S\$) :</b>			<b>10.00</b>

---

**Deposit Service Account No. : 030066**  
**Balance Amount in Deposit Account : \$ 375.00**

This is a computer-generated receipt. No signature is required.

Please print a copy of the receipt for your reference.

<a href="#">HOME</a>	<a href="#">LOGOUT</a>
----------------------	------------------------

**Return of Allotment of Shares****Submit**

Please fill in the following information. Fields marked \* must be completed.

Resolution/Declaration	Shares payable in cash	For a consideration <u>other than cash</u>	Share Capital/Allottees Particulars	List of Shareholders after the allotment	Summary of Capital
------------------------	---------------------------	--	---	---	-----------------------

**Record saved successfully.****Company Type**

Please click on appropriate button :

- company is listed on the securities exchange
- company is an unlisted public company
- company is a private company

**Power under Section 161 of the Companies Act \***

The directors have obtained the approval of the company in  Yes  No general meeting to issue shares.

**Resolution Made**

\* You are only required to fill in this section if the directors are not given the power under Section 161 of the Companies Act to issue shares.

Registration No. : **197201770G**Company Name : **SINGAPORE AIRPORT TERMINAL SERVICES LIMITED**Nature of Meeting : \* **Directors** ▼Place of Meeting : \* Date of Meeting : \*  (dd/mm/yyyy)Resolution Type : \* **Director's** ▼Description : \*   
(max 2000 characters)Attachment : \*  
(copy of resolution)**Note :**  **Browse..**

Uploaded file name will be changed by suffixing time-stamp with the actual file name as  
**filenameyyyyMMddmmsstt**  
 (Click 'Browse' to select file for attachment)

**Persons signing the resolution**

Please indicate the directors/ secretaries who signed the resolution :

- S0036442H / OW CHIN HOCK
- S0070715E / NG KEE CHOE
- S0234645A / CHEW CHOON SENG
- S1001765C / BARRY HENRY PATRICK DESKER
- S1069567H / TAN JIAK NGEE MICHAEL
- S1673157I / YIP WAI PING ANNABELLE
- S1852301I / HONG HAI @ HUANG HAI
- S2163476Z / CHENG WAI WING EDMUND
- S2580327B / RICHARD CHARLES HELFER

Please enter names of other corporate representatives who signed the resolution, if applicable :

**Declaration**

I, LIM HONG ENG SUSANNA, Professional body/service bureau, declare the information which has been submitted herein to be true to the best of my knowledge.

**Return of Allotment of Shares**

[Submit](#)

Please fill in the following information. Fields marked \* must be completed.

Resolution / Declaration	Share payable in cash	For a consideration other than cash	Share Capital / Allottees Particulars	List of Shareholders after the Allotment	Summary of Capital
--------------------------	-----------------------	-------------------------------------	---------------------------------------	--	--------------------

**Authorised Capital**

	Amount	Nominal Value per Share	Currency
Authorised Capital :	<b>200000000</b>	<b>.1</b>	<b>SINGAPORE DOLLAR ( 099 )</b>

Description of discrepancy :

**Return of Allotment of Shares (Payable in cash) \***

Applicable only if share is payable in cash

Class of Shares :	Ordinary	Preference	Others
Number of shares :	<input type="text" value="2600"/>	<input type="text"/>	<input type="text"/>
Amount paid or due and payable on each share			
paid :	<input type="text" value="0.10"/>	<input type="text"/>	<input type="text"/>
due and payable :	<input type="text" value="0"/>	<input type="text"/>	<input type="text"/>
Amount of premium paid or payable on each share :	<input type="text" value="1.14"/>	<input type="text"/>	<input type="text"/>

[Save](#)   [Delete Issued Share](#)   [Reset](#)   [Back](#)



**Return of Allotment of Shares****Submit**

Please fill in the following information. Fields marked \* must be completed.

Resolution / Declaration	Share payable in cash	For a consideration other than cash	Share Capital / Allottees Particulars	List of Shareholders after the allotment	Summary of Capital
--------------------------	-----------------------	-------------------------------------	---------------------------------------	--	--------------------

**Particulars of Allottee**

Please indicate whether the allottee is an Individual : \*

- Allottee is an Individual
- Allottee is NOT an Individual

**If Allottee is an Individual :**Shareholder Category : \* **Individual**Identification No. : \*  **Retrieve Details**Identification Type : \* Name : \* Nationality : \* Mobile No. : Occupation : Email Address : Address Type : \*  Local  
 Foreign

Local Address (\* if Address Type is Local Address)

Postal Code :  **Retrieve Address**Block/House No. : Street Name : Unit : #  - Building/Estate Name : 

Foreign Address (\* if Address Type is Foreign Address)

Address : **If Allottee is NOT an Individual :**Shareholder Category : \*  **Search**

Registration No. : **THE CENTRAL DEPOSITORY (PTE) LIMITED**

Address Type : **Local**

Local Address (\* if Address Type is Local Address)

Postal Code : **068804**

Block/House No. : **2**

Street Name : **SHENTON WAY**

Unit : # **19 - 00**

Building/Estate Name : **SGX CENTRE I**

Foreign Address (\* if Address Type is Foreign Address)

Address :

**Details of Shares Allotted** \* Please read instructions carefully before entering.

Note : If any share or shares is/are co-owned by 2 or more persons, please assign an alphabet e.g. A to denote the Group and enter the same in the box. Enter the same alphabet in the box for every allottee in the same group. Skip this box if share(s) are owned by only one person.

Group of Share that is co-owned:  
(Share Group)

If share(s) is/are co-owned, only one allottee is to enter details in (a), (b), (c), (d) and (e). Enter "0" (zero) for subsequent allottees in box (b) and leave blank for rest of the items.

- a) Nominal Value per Share :
- b) No. of shares allotted :
- c) Class of shares allotted :
- d) Currency :
- e) Date of allotment :  (dd/mm/yyyy)

**Return of Allotment of Shares****Submit**

Please fill in the following information. Fields marked \* must be completed.

<b>Resolution / Declaration</b>	<b>Share payable in cash</b>	<b>For a consideration other than cash</b>	<b>Share Capital / Allottees Particulars</b>	<b>List of Shareholders after Allotment</b>	<b>Summary of Capital</b>
-------------------------------------	----------------------------------	--	--	---	-------------------------------

**List of Allottees and their particulars****Identification****No./Registration Name  
No.****Shareholder Category**

198003912M	THE CENTRAL DEPOSITORY (PTE) LIMITED	Company / Foreign Branch
------------	---	--------------------------

If No. of shareholders exceeds 50, total No. of issued shares held by the remaining shareholders are :

<b>No. of Shares</b>	<b>Ordinary</b>	<b>Preference</b>	<b>Others</b>
	0	0	0

**Return of Allotment of Shares****Submit**

Please fill in the following information. Fields marked \* must be completed.

<b>Resolution / Declaration</b>	<b>Share payable in cash</b>	<b>For a consideration other than cash</b>	<b>Share Capital / Allottees Particulars</b>	<b>List of Shareholders after the allotment</b>	<b>Summary of Capital</b>
<b>Share Capital (1)</b>					
Currency :	<b>SINGAPORE DOLLAR (099)</b>				
Nominal Value per Share :	<b>0.10</b>				
Amount of Authorised Share Capital :	<b>200000000.00</b>				
Class of Shares :	Ordinary	Preference	Others		
Amount of Issued Share Capital :	<b>102589192.50</b>	<b>0.00</b>	<b>0.00</b>		
Amount of Paid-up Share Capital :	<b>102589192.50</b>	<b>0.00</b>	<b>0.00</b>		

GST No. :M9-0008879-T

**RECEIPT**

Receipt No : ACR0000000927823A

Date/Time : 05/11/2004 09:28

Transaction No : C040505395

Agency : RCB - RCB

Application : BIZFILE PAYMENT SERVICE

Paid via : Deposit Service Account

EP Ref No :

**SINGAPORE AIRPORT TERMINAL SERVICES LIMITED  
20 AIRPORT BOULEVARD  
SATS INFLIGHT CATERING CENTRE 3  
SINGAPORE 819659**

---

<b>Sno Code/Description</b>	<b>Unit Price (S\$)</b>	<b>Qty</b>	<b>Amount</b>
1 Lodgment Of Return Of Allotment Of Share <b>COMPANY/BUSINESS NAME :</b> 197201770G / SINGAPORE AIRPORT TERMINAL SERVICES LIMITED	10.00	1	10.00
<b>Total (S\$) :</b>			<b>10.00</b>

---

**Deposit Service Account No. : 030066  
Balance Amount in Deposit Account : \$ 385.00**

This is a computer-generated receipt. No signature is required.

Please print a copy of the receipt for your reference.

[HOME](#)[LOGOUT](#)

**LOCAL COMPANY TRANSACTIONS**[HOME](#)[LOGOUT](#)**Return of Allotment of Shares**[Submit](#)

Please fill in the following information. Fields marked \* must be completed.

Resolution/Declaration	Shares payable in cash	For a consideration other than cash	Share Capital/Allottees Particulars	List of Shareholders after the allotment	Summary of Capital
------------------------	---------------------------	---	---	---	-----------------------

**Record saved successfully.****Company Type**

Please click on appropriate button :

- company is listed on the securities exchange  
 company is an unlisted public company  
 company is a private company

**Power under Section 161 of the Companies Act \***

The directors have obtained the approval of the company in  Yes  No general meeting to issue shares.

**Resolution Made**

\* You are only required to fill in this section if the directors are not given the power under Section 161 of the Companies Act to issue shares.

Registration No. : **197201770G**Company Name : **SINGAPORE AIRPORT TERMINAL SERVICES LIMITED**Nature of Meeting : \* 

Place of Meeting : \*

Date of Meeting : \*  (dd/mm/yyyy)Resolution Type : \* Description : \*  
(max 2000 characters)Attachment : \*  
(copy of resolution)**Note :**

Uploaded file name will be changed by suffixing time-stamp with the actual file name as

**filenameyyyyMMddmmsstt**[Browse...](#)

(Click 'Browse' to select file for attachment)

**Persons signing the resolution**

Please indicate the directors/ secretaries who signed the resolution :

- S0036442H / OW CHIN HOCK
- S0070715E / NG KEE CHOE
- S0234645A / CHEW CHOON SENG
- S1001765C / BARRY HENRY PATRICK DESKER
- S1069567H / TAN JIAK NGEE MICHAEL
- S1673157I / YIP WAI PING ANNABELLE
- S1852301I / HONG HAI @ HUANG HAI
- S2163476Z / CHENG WAI WING EDMUND
- S2580327B / RICHARD CHARLES HELFER

Please enter names of other corporate representatives who signed the resolution, if applicable :

**Declaration**

I, LIM HONG ENG SUSANNA, Professional body/service bureau, declare the information which has been submitted herein to be true to the best of my knowledge.

**Return of Allotment of Shares****Submit**

Please fill in the following information. Fields marked \* must be completed.

Resolution / Declaration	Share payable in cash	For a consideration other than cash	Share Capital / Allottees Particulars	List of Shareholders after the Allotment	Summary of Capital
--------------------------	-----------------------	-------------------------------------	---------------------------------------	--	--------------------

**Authorised Capital**

	Amount	Nominal Value per Share	Currency
Authorised Capital :	<b>20000000</b>	<b>.1</b>	<b>SINGAPORE DOLLAR ( 099 )</b>

Description of discrepancy :

**Return of Allotment of Shares (Payable in cash) \***

Applicable only if share is payable in cash

Class of Shares :	Ordinary	Preference	Others
Number of shares :	2600		
Amount paid or due and payable on each share			
paid :	0.10		
due and payable :	0		
Amount of premium paid or payable on each share :	1.70		

**Save****Delete Issued Share****Reset****Back**



**Return of Allotment of Shares****Submit**

Please fill in the following information. Fields marked \* must be completed.

Resolution / Declaration	Share payable in cash	For a consideration other than cash	Share Capital / Allottees Particulars	List of Shareholders after the allotment	Summary of Capital
-----------------------------	--------------------------	---	---	---	-----------------------

**Particulars of Allottee**

Please indicate whether the allottee is an Individual : \*

- Allottee is an Individual  
 Allottee is NOT an Individual

If Allottee is an Individual :

Shareholder Category : \* **Individual**

Identification No. : \*

**Retrieve Details**

Identification Type : \*

NRIC

Name : \*

Nationality : \*

Mobile No :

Occupation :

Email Address :

Address Type : \*

- Local  
 Foreign

Local Address (\* if Address Type is Local Address)

Postal Code :

**Retrieve Address**

Block/House No. :

Street Name :

Unit : #

 - 

Building/Estate Name :

Foreign Address (\* if Address Type is Foreign Address)

Address :

If Allottee is NOT an Individual :

Shareholder Category : \*

Company / Foreign Branch

**Search**

Registration No. : \*    
Name : **THE CENTRAL DEPOSITORY (PTE) LIMITED**

Address Type : **Local**

Local Address (\* if Address Type is Local Address)

Postal Code : **068804**

Block/House No. : **2**

Street Name : **SHENTON WAY**

Unit : # **19 - 00**

Building/Estate Name : **SGX CENTRE I**

Foreign Address (\* if Address Type is Foreign Address)

Address :

**Details of Shares Allotted** \* Please read instructions carefully before entering.

Note : If any share or shares is/are co-owned by 2 or more persons, please assign an alphabet e.g. A to denote the Group and enter the same in the box. Enter the same alphabet in the box for every allottee in the same group. Skip this box if share(s) are owned by only one person.

Group of Share that is co-owned:  
(Share Group)

If share(s) is/are co-owned, only one allottee is to enter details in (a), (b), (c), (d) and (e). Enter "0" (zero) for subsequent allottees in box (b) and leave blank for rest of the items.

- a) Nominal Value per Share :
- b) No. of shares allotted :
- c) Class of shares allotted :
- d) Currency :
- e) Date of allotment :  (dd/mm/yyyy)

**Return of Allotment of Shares**[Submit](#)

Please fill in the following information. Fields marked \* must be completed.

<b>Resolution / Declaration</b>	<b>Share payable in cash</b>	<b>For a consideration other than cash</b>	<b>Share Capital / Allottees Particulars</b>	<b>List of Shareholders after Allotment</b>	<b>Summary of Capital</b>
-------------------------------------	----------------------------------	--	--	---	-------------------------------

**List of Allottees and their particulars****Identification****No./Registration Name  
No.****Shareholder Category**

198003912M	THE CENTRAL DEPOSITORY (PTE) LIMITED	Company / Foreign Branch
------------	---	--------------------------

If No. of shareholders exceeds 50, total No. of issued shares held by the remaining shareholders are :

<b>No. of Shares</b>	<b>Ordinary</b>	<b>Preference</b>	<b>Others</b>
	0	0	0

**Return of Allotment of Shares**[Submit](#)

Please fill in the following information. Fields marked \* must be completed.

<u>Resolution / Declaration</u>	<u>Share payable in cash</u>	<u>For a consideration other than cash</u>	<u>Share Capital / Allottees Particulars</u>	<u>List of Shareholders after the allotment</u>	<u>Summary of Capital</u>
<b>Share Capital (1)</b>					
Currency :	<b>SINGAPORE DOLLAR (099)</b>				
Nominal Value per Share :	<b>0.10</b>				
Amount of Authorised Share Capital :	<b>200000000.00</b>				
Class of Shares :	Ordinary	Preference	Others		
Amount of Issued Share Capital :	<b>102588932.50</b>	<b>0.00</b>	<b>0.00</b>		
Amount of Paid-up Share Capital :	<b>102588932.50</b>	<b>0.00</b>	<b>0.00</b>		

GST No. :M9-0008879-T

**RECEIPT**

Receipt No : ACR0000000926340A

Date/Time : 04/11/2004 10:02

Transaction  
No : C040503790

Agency : RCB - RCB

Application : BIZFILE PAYMENT SERVICE

Paid via : Deposit Service Account

EP Ref No :

**SINGAPORE AIRPORT TERMINAL SERVICES LIMITED****20 AIRPORT BOULEVARD****SATS INFLIGHT CATERING CENTRE 3****SINGAPORE 819659**

---

<b>Sno Code/Description</b>	<b>Unit Price (S\$)</b>	<b>Qty</b>	<b>Amount</b>
1 Lodgment Of Return Of Allotment Of Share <b>COMPANY/BUSINESS NAME :</b> 197201770G / SINGAPORE AIRPORT TERMINAL SERVICES LIMITED	10.00	1	10.00
<b>Total (S\$) :</b>			<b>10.00</b>

---

**Deposit Service Account No. : 030066****Balance Amount in Deposit Account : \$ 395.00**

This is a computer-generated receipt. No signature is required.

Please print a copy of the receipt for your reference.

[HOME](#)[LOGOUT](#)

**Return of Allotment of Shares**

Submit

Please fill in the following information. Fields marked \* must be completed.

Resolution/Declaration	Shares payable in cash	For a consideration other than cash	Share Capital/Allottees Particulars	List of Shareholders after the allotment	Summary of Capital
------------------------	---------------------------	---	---	---	-----------------------

**Record saved successfully.****Company Type**

Please click on appropriate button :

- company is listed on the securities exchange  
 company is an unlisted public company  
 company is a private company

**Power under Section 161 of the Companies Act \***

The directors have obtained the approval of the company in  Yes  No general meeting to issue shares.

**Resolution Made**

\* You are only required to fill in this section if the directors are not given the power under Section 161 of the Companies Act to issue shares.

Registration No. : **197201770G**Company Name : **SINGAPORE AIRPORT TERMINAL SERVICES LIMITED**

Nature of Meeting : \* Directors

Place of Meeting : \*

Date of Meeting : \* (dd/mm/yyyy)

Resolution Type : \* Director's

Description : \*  
(max 2000 characters)Attachment : \*  
(copy of resolution)**Note :**

Uploaded file name will be changed by suffixing time-stamp with the actual file name as

filenameyyyyMMddmmsstt

Browse...

(Click 'Browse' to select file for attachment)

**Persons signing the resolution**

Please indicate the directors/ secretaries who signed the resolution :

- S0036442H / OW CHIN HOCK
- S0070715E / NG KEE CHOE
- S0234645A / CHEW CHOON SENG
- S1001765C / BARRY HENRY PATRICK DESKER
- S1069567H / TAN JIAK NGEE MICHAEL
- S1673157I / YIP WAI PING ANNABELLE
- S1852301I / HONG HAI @ HUANG HAI
- S2163476Z / CHENG WAI WING EDMUND
- S2580327B / RICHARD CHARLES HELFER

Please enter names of other corporate representatives who signed the resolution, if applicable :

**Declaration**

I, LIM HONG ENG SUSANNA, Professional body/service bureau, declare the information which has been submitted herein to be true to the best of my knowledge.

**Return of Allotment of Shares**

[Submit](#)

Please fill in the following information. Fields marked \* must be completed.

Resolution / Declaration	Share payable in cash	For a consideration other than cash	Share Capital / Allottees Particulars	List of Shareholders after the Allotment	Summary of Capital
--------------------------	-----------------------	-------------------------------------	---------------------------------------	--	--------------------

**Authorised Capital**

	Amount	Nominal Value per Share	Currency
Authorised Capital :	<b>200000000</b>	<b>.1</b>	<b>SINGAPORE DOLLAR ( 099 )</b>

Description of discrepancy :

**Return of Allotment of Shares (Payable in cash) \***

Applicable only if share is payable in cash

Class of Shares :	Ordinary	Preference	Others
Number of shares :	<input type="text" value="15600"/>	<input type="text"/>	<input type="text"/>
Amount paid or due and payable on each share			
paid :	<input type="text" value="0.10"/>	<input type="text"/>	<input type="text"/>
due and payable :	<input type="text" value="0"/>	<input type="text"/>	<input type="text"/>
Amount of premium paid or payable on each share :	<input type="text" value="1.50"/>	<input type="text"/>	<input type="text"/>

[Save](#)   [Delete Issued Share](#)   [Reset](#)   [Back](#)



**Return of Allotment of Shares****Submit**

Please fill in the following information. Fields marked \* must be completed.

Resolution / Declaration	Share payable in cash	For a consideration other than cash	Share Capital / Allottees Particulars	List of Shareholders after the allotment	Summary of Capital
--------------------------	-----------------------	-------------------------------------	---------------------------------------	--	--------------------

**Particulars of Allottee****Please indicate whether the allottee is an Individual : \***

- Allottee is an Individual  
 Allottee is NOT an Individual

**If Allottee is an Individual :**Shareholder Category : \* **Individual**

Identification No. : \*

**Retrieve Details**

Identification Type : \*

NRIC 

Name : \*

Nationality : \*

Mobile No. :

Occupation :

Email Address :

Address Type : \*

- Local  
 Foreign

Local Address (\* if Address Type is Local Address)

Postal Code :

**Retrieve Address**

Block/House No. :

Street Name :

Unit : #

 - 

Building/Estate Name :

Foreign Address (\* if Address Type is Foreign Address)

Address :

**If Allottee is NOT an Individual :**

Shareholder Category : \*

Company / Foreign Branch

**Search**

Registration No. :  Name : **THE CENTRAL DEPOSITORY (PTE) LIMITED**

Address Type : **Local**

Local Address (\* if Address Type is Local Address)

Postal Code : **068804**

Block/House No. : **2**

Street Name : **SHENTON WAY**

Unit : # **19 - 00**

Building/Estate Name : **SGX CENTRE I**

Foreign Address (\* if Address Type is Foreign Address)

Address :

**Details of Shares Allotted** \* Please read instructions carefully before entering.

Note : If any share or shares is/are co-owned by 2 or more persons, please assign an alphabet e.g. A to denote the Group and enter the same in the box. Enter the same alphabet in the box for every allottee in the same group. Skip this box if share(s) are owned by only one person.

Group of Share that is co-owned:  
(Share Group)

If share(s) is/are co-owned, only one allottee is to enter details in (a), (b), (c), (d) and (e). Enter "0" (zero) for subsequent allottees in box (b) and leave blank for rest of the items.

a) Nominal Value per Share :

b) No. of shares allotted :

c) Class of shares allotted :

d) Currency :

e) Date of allotment :  (dd/mm/yyyy)

**Return of Allotment of Shares**

Please fill in the following information. Fields marked \* must be completed.

Resolution / Declaration	Share payable in cash	For a consideration other than cash	Share Capital / Allottees Particulars	List of Shareholders after Allotment	Summary of Capital
-----------------------------	--------------------------	---	---	--	-----------------------

**List of Allottees and their particulars****Identification****No./Registration Name  
No.****Shareholder Category**

198003912M	THE CENTRAL DEPOSITORY (PTE) LIMITED	Company / Foreign Branch
------------	---	--------------------------

If No. of shareholders exceeds 50, total No. of issued shares held by the remaining shareholders are :

No. of Shares	Ordinary	Preference	Others
	0	0	0

**Return of Allotment of Shares****Submit**

Please fill in the following information. Fields marked \* must be completed.

<u>Resolution / Declaration</u>	<u>Share payable in cash</u>	<u>For a consideration other than cash</u>	<u>Share Capital / Allottees Particulars</u>	<u>List of Shareholders after the allotment</u>	<u>Summary of Capital</u>
---------------------------------	------------------------------	--	--	---	---------------------------

**Share Capital (1)**Currency : **SINGAPORE DOLLAR (099)**Nominal Value per Share : **0.10**Amount of Authorised Share Capital : **200000000.00**

Class of Shares : Ordinary Preference Others

Amount of Issued Share Capital : **102588672.50 0.00 0.00**Amount of Paid-up Share Capital : **102588672.50 0.00 0.00**

GST No. :M9-0008879-T

**RECEIPT**

Receipt No : ACR0000000926327A

Date/Time : 04/11/2004 09:56

Transaction  
No : C040503776

Agency : RCB - RCB

Application : BIZFILE PAYMENT SERVICE

Paid via : Deposit Service Account

EP Ref No :

**SINGAPORE AIRPORT TERMINAL SERVICES LIMITED  
20 AIRPORT BOULEVARD  
SATS INFLIGHT CATERING CENTRE 3  
SINGAPORE 819659**

<b>Sno Code/Description</b>	<b>Unit Price (S\$)</b>	<b>Qty</b>	<b>Amount</b>
1 Lodgment Of Return Of Allotment Of Share <b>COMPANY/BUSINESS NAME :</b> 197201770G / SINGAPORE AIRPORT TERMINAL SERVICES LIMITED	10.00	1	10.00
<b>Total (S\$) :</b>			<b>10.00</b>

**Deposit Service Account No. : 030066**  
**Balance Amount in Deposit Account : \$ 405.00**

This is a computer-generated receipt. No signature is required.

Please print a copy of the receipt for your reference.

[HOME](#)[LOGOUT](#)

**Return of Allotment of Shares****Submit**

Please fill in the following information. Fields marked \* must be completed.

Resolution/Declaration	Shares payable in cash	For a consideration other than cash	Share Capital/Allottees Particulars	List of Shareholders after the allotment	Summary of Capital
------------------------	---------------------------	---	---	---	-----------------------

**Record saved successfully.****Company Type**

Please click on appropriate button :

- company is listed on the securities exchange  
 company is an unlisted public company  
 company is a private company

**Power under Section 161 of the Companies Act \***

The directors have obtained the approval of the company in  Yes  No general meeting to issue shares.

**Resolution Made**

\* You are only required to fill in this section if the directors are not given the power under Section 161 of the Companies Act to issue shares.

Registration No. : **197201770G**Company Name : **SINGAPORE AIRPORT TERMINAL SERVICES LIMITED**Nature of Meeting : \*  ▼Place of Meeting : \* Date of Meeting : \*  (dd/mm/yyyy)Resolution Type : \*  ▼Description : \*  
(max 2000 characters)Attachment : \*  
(copy of resolution)**Note :**

Uploaded file name will be changed by suffixing time-stamp with the actual file name as

filenameyyyyMMddmmsstt

 **Browse...**

(Click 'Browse' to select file for attachment)

**Persons signing the resolution**

Please indicate the directors/ secretaries who signed the resolution :

- S0036442H / OW CHIN HOCK
- S0070715E / NG KEE CHOE
- S0234645A / CHEW CHOON SENG
- S1001765C / BARRY HENRY PATRICK DESKER
- S1069567H / TAN JIAK NGEE MICHAEL
- S1673157I / YIP WAI PING ANNABELLE
- S1852301I / HONG HAI @ HUANG HAI
- S2163476Z / CHENG WAI WING EDMUND
- S2580327B / RICHARD CHARLES HELFER

Please enter names of other corporate representatives who signed the resolution, if applicable :

**Declaration**

I, LIM HONG ENG SUSANNA, Professional body/service bureau, declare the information which has been submitted herein to be true to the best of my knowledge.

**Return of Allotment of Shares**

[Submit](#)

Please fill in the following information. Fields marked \* must be completed.

<u>Resolution / Declaration</u>	Share payable in cash	For a consideration other than cash	Share Capital / Allottees Particulars	List of Shareholders after the Allotment	Summary of Capital
---------------------------------	-----------------------	-------------------------------------	---------------------------------------	--	--------------------

**Authorised Capital**

	Amount	Nominal Value per Share	Currency
Authorised Capital :	<b>200000000</b>	<b>.1</b>	<b>SINGAPORE DOLLAR ( 099 )</b>

Description of discrepancy :

**Return of Allotment of Shares (Payable in cash) \***

Applicable only if share is payable in cash

Class of Shares :	Ordinary	Preference	Others
Number of shares :	<input type="text" value="13000"/>	<input type="text"/>	<input type="text"/>
Amount paid or due and payable on each share			
paid :	<input type="text" value="0.10"/>	<input type="text"/>	<input type="text"/>
due and payable :	<input type="text" value="0"/>	<input type="text"/>	<input type="text"/>
Amount of premium paid or payable on each share :	<input type="text" value="1.14"/>	<input type="text"/>	<input type="text"/>

[Save](#)   [Delete Issued Share](#)   [Reset](#)   [Back](#)



**Return of Allotment of Shares**

Submit

Please fill in the following information. Fields marked \* must be completed.

Resolution / Declaration	Share payable in cash	For a consideration other than cash	Share Capital / Allottees Particulars	List of Shareholders after the allotment	Summary of Capital
--------------------------	-----------------------	-------------------------------------	---------------------------------------	--	--------------------

**Particulars of Allottee**

Please indicate whether the allottee is an Individual : \*

- Allottee is an Individual  
 Allottee is NOT an Individual

If Allottee is an Individual :

Shareholder Category : \* **Individual**

Identification No. : \*

Retrieve Details

Identification Type : \*

NRIC

Name : \*

Nationality : \*

Mobile No :

Occupation :

Email Address :

Address Type : \*

- Local  
 Foreign

Local Address (\* if Address Type is Local Address)

Postal Code :

Retrieve Address

Block/House No. :

Street Name :

Unit : #

 - 

Building/Estate Name :

Foreign Address (\* if Address Type is Foreign Address)

Address :

If Allottee is NOT an Individual :

Shareholder Category : \*

Company / Foreign Branch

Search

Registration No. : \*

198003912M

Retrieve Details

Name :

**THE CENTRAL DEPOSITORY (PTE) LIMITED**

Address Type :

**Local**

Local Address (\* if Address Type is Local Address)

Postal Code : **068804**

Block/House No. : **2**

Street Name : **SHENTON WAY**

Unit : # **19 - 00**

Building/Estate Name : **SGX CENTRE I**

Foreign Address (\* if Address Type is Foreign Address)

Address :

**Details of Shares Allotted** \* Please read instructions carefully before entering.

Note : If any share or shares is/are co-owned by 2 or more persons, please assign an alphabet e.g. A to denote the Group and enter the same in the box. Enter the same alphabet in the box for every allottee in the same group. Skip this box if share(s) are owned by only one person.

Group of Share that is co-owned:  
(Share Group)

If share(s) is/are co-owned, only one allottee is to enter details in (a), (b), (c), (d) and (e). Enter "0" (zero) for subsequent allottees in box (b) and leave blank for rest of the items.

a) Nominal Value per Share :

0.10

b) No. of shares allotted :

13000

c) Class of shares allotted :

Ordinary

d) Currency :

SINGAPORE DOLLAR (099)

e) Date of allotment :

01/11/2004

(dd/mm/yyyy)

Save

Reset

Back

**Return of Allotment of Shares**

Please fill in the following information. Fields marked \* must be completed.

<b>Resolution / Declaration</b>	<b>Share payable in cash</b>	<b>For a consideration other than cash</b>	<b>Share Capital / Allottees Particulars</b>	<b>List of Shareholders after Allotment</b>	<b>Summary of Capital</b>
-------------------------------------	----------------------------------	--	--	---	-------------------------------

**List of Allottees and their particulars****Identification****No./Registration Name  
No.****Shareholder Category**

198003912M	THE CENTRAL DEPOSITORY (PTE) LIMITED	Company / Foreign Branch
------------	---	--------------------------

If No. of shareholders exceeds 50, total No. of issued shares held by the remaining shareholders are :

<b>No. of Shares</b>	<b>Ordinary</b>	<b>Preference</b>	<b>Others</b>
	0	0	0

**Return of Allotment of Shares****Submit**

Please fill in the following information. Fields marked \* must be completed.

Resolution / Declaration	Share payable in cash	For a consideration other than cash	Share Capital / Allottees Particulars	List of Shareholders after the allotment	Summary of Capital
--------------------------	-----------------------	-------------------------------------	---------------------------------------	--	--------------------

**Share Capital (1)**

Currency :	<b>SINGAPORE DOLLAR (099)</b>		
Nominal Value per Share :	<b>0.10</b>		
Amount of Authorised Share Capital :	<b>200000000.00</b>		
Class of Shares :	Ordinary	Preference	Others
Amount of Issued Share Capital :	<b>102587112.50</b>	<b>0.00</b>	<b>0.00</b>
Amount of Paid-up Share Capital :	<b>102587112.50</b>	<b>0.00</b>	<b>0.00</b>

GST No. :M9-0008879-T

**RECEIPT**

Receipt No : ACR0000000926310A

Date/Time : 04/11/2004 09:49

Transaction No : C040503757

Agency : RCB - RCB

Application : BIZFILE PAYMENT SERVICE

Paid via : Deposit Service Account

EP Ref No :

**SINGAPORE AIRPORT TERMINAL SERVICES LIMITED**  
**20 AIRPORT BOULEVARD**  
**SATS INFLIGHT CATERING CENTRE 3**  
**SINGAPORE 819659**

---

<b>Sno Code/Description</b>	<b>Unit Price (S\$)</b>	<b>Qty</b>	<b>Amount</b>
1 Lodgment Of Return Of Allotment Of Share <b>COMPANY/BUSINESS NAME :</b> 197201770G / SINGAPORE AIRPORT TERMINAL SERVICES LIMITED	10.00	1	10.00
<b>Total (S\$) :</b>			<b>10.00</b>

---

**Deposit Service Account No. : 030066**  
**Balance Amount in Deposit Account : \$ 415.00**

This is a computer-generated receipt. No signature is required.

Please print a copy of the receipt for your reference.

<a href="#">HOME</a>	<a href="#">LOGOUT</a>
----------------------	------------------------

**Return of Allotment of Shares**

Submit

Please fill in the following information. Fields marked \* must be completed.

Resolution/Declaration	Shares payable in cash	For a consideration other than cash	Share Capital/Allottees Particulars	List of Shareholders after the allotment	Summary of Capital
------------------------	---------------------------	---	---	---	-----------------------

**Record saved successfully.****Company Type**

Please click on appropriate button :

- company is listed on the securities exchange  
 company is an unlisted public company  
 company is a private company

**Power under Section 161 of the Companies Act \***

The directors have obtained  
the approval of the company in  Yes  
general meeting to issue  No  
shares.

**Resolution Made**

\* You are only required to fill in this section if the directors are not given the power under Section 161 of the Companies Act to issue shares.

Registration No. : **197201770G**Company Name : **SINGAPORE AIRPORT TERMINAL SERVICES LIMITED**

Nature of Meeting : \* Directors

Place of Meeting : \*

Date of Meeting : \* (dd/mm/yyyy)

Resolution Type : \* Director's

Description : \*  
(max 2000 characters)Attachment : \*  
(copy of resolution)**Note :**

Uploaded file name will be  
changed by suffixing time-  
stamp with the actual file  
name as

filenameyyyyMMddmmsstt

Browse...

(Click 'Browse' to select file for attachment)

**Persons signing the resolution**

Please indicate the directors/ secretaries who signed the resolution :

- S0036442H / OW CHIN HOCK
- S0070715E / NG KEE CHOE
- S0234645A / CHEW CHOON SENG
- S1001765C / BARRY HENRY PATRICK DESKER
- S1069567H / TAN JIAK NGEE MICHAEL
- S1673157I / YIP WAI PING ANNABELLE
- S1852301I / HONG HAI @ HUANG HAI
- S2163476Z / CHENG WAI WING EDMUND
- S2580327B / RICHARD CHARLES HELFER

Please enter names of other corporate representatives who signed the resolution, if applicable :

**Declaration**

I, LIM HONG ENG SUSANNA, Professional body/service bureau, declare the information which has been submitted herein to be true to the best of my knowledge.

**Return of Allotment of Shares**

**Submit**

Please fill in the following information. Fields marked \* must be completed.

<b>Resolution / Declaration</b>	<b>Share payable in cash</b>	<b>For a consideration other than cash</b>	<b>Share Capital / Allottees Particulars</b>	<b>List of Shareholders after the Allotment</b>	<b>Summary of Capital</b>
-------------------------------------	----------------------------------	--	--	---	-------------------------------

**Authorised Capital**

	<b>Amount</b>	<b>Nominal Value per Share</b>	<b>Currency</b>
Authorised Capital :	<b>200000000</b>	<b>.1</b>	<b>SINGAPORE DOLLAR ( 099 )</b>

Description of discrepancy :

**Return of Allotment of Shares (Payable in cash) \***

Applicable only if share is payable in cash

<b>Class of Shares :</b>	<b>Ordinary</b>	<b>Preference</b>	<b>Others</b>
Number of shares :	<input type="text" value="39450"/>	<input type="text"/>	<input type="text"/>
Amount paid or due and payable on each share			
paid :	<input type="text" value="0.10"/>	<input type="text"/>	<input type="text"/>
due and payable :	<input type="text" value="0"/>	<input type="text"/>	<input type="text"/>
Amount of premium paid or payable on each share :	<input type="text" value="1.70"/>	<input type="text"/>	<input type="text"/>

**Save**    **Delete Issued Share**    **Reset**    **Back**



**Return of Allotment of Shares****Submit**

Please fill in the following information. Fields marked \* must be completed.

<b>Resolution / Declaration</b>	<b>Share payable in cash</b>	<b>For a consideration other than cash</b>	<b>Share Capital / Allottees Particulars</b>	<b>List of Shareholders after the allotment</b>	<b>Summary of Capital</b>
-------------------------------------	----------------------------------	--	--	---	-------------------------------

**Particulars of Allottee****Please indicate whether the allottee is an Individual : \***

- Allottee is an Individual  
 Allottee is NOT an Individual

**If Allottee is an Individual :**Shareholder Category : \* **Individual**Identification No. : \*  **Retrieve Details**Identification Type : \*  ▼Name : \* Nationality : \*  ▼Mobile No : Occupation : Email Address : Address Type : \*  
 Local  
 Foreign

Local Address (\* if Address Type is Local Address)

Postal Code :  **Retrieve Address**Block/House No. :  ▼Street Name : Unit : #  - Building/Estate Name : 

Foreign Address (\* if Address Type is Foreign Address)

Address : **If Allottee is NOT an Individual :**Shareholder Category : \*  ▼ **Search**

Registration No. : \*

198003912M

Retrieve Details

Name :

**THE CENTRAL DEPOSITORY (PTE) LIMITED**

Address Type :

**Local**

Local Address (\* if Address Type is Local Address)

Postal Code : **068804**

Block/House No. : **2**

Street Name : **SHENTON WAY**

Unit : # **19 - 00**

Building/Estate Name : **SGX CENTRE I**

Foreign Address (\* if Address Type is Foreign Address)

Address :

**Details of Shares Allotted** \* Please read instructions carefully before entering.

Note : If any share or shares is/are co-owned by 2 or more persons, please assign an alphabet e.g. A to denote the Group and enter the same in the box. Enter the same alphabet in the box for every allottee in the same group. Skip this box if share(s) are owned by only one person.

Group of Share that is co-owned:  
(Share Group)

If share(s) is/are co-owned, only one allottee is to enter details in (a), (b), (c), (d) and (e). Enter "0" (zero) for subsequent allottees in box (b) and leave blank for rest of the items.

a) Nominal Value per Share :

0.10

b) No. of shares allotted :

39450

c) Class of shares allotted :

Ordinary

d) Currency :

SINGAPORE DOLLAR (099)

e) Date of allotment :

01/11/2004 (dd/mm/yyyy)

Save Reset Back

**Return of Allotment of Shares****Submit**

Please fill in the following information. Fields marked \* must be completed.

<b>Resolution / Declaration</b>	<b>Share payable in cash</b>	<b>For a consideration other than cash</b>	<b>Share Capital / Allottees Particulars</b>	<b>List of Shareholders after Allotment</b>	<b>Summary of Capital</b>
-------------------------------------	----------------------------------	--	--	---	-------------------------------

**List of Allottees and their particulars****Identification****No./Registration Name  
No.****Shareholder Category**

198003912M	THE CENTRAL DEPOSITORY (PTE) LIMITED	Company / Foreign Branch
------------	---	--------------------------

If No. of shareholders exceeds 50, total No. of issued shares held by the remaining shareholders are :

	<b>Ordinary</b>	<b>Preference</b>	<b>Others</b>
<b>No. of Shares</b>	<b>0</b>	<b>0</b>	<b>0</b>

**Return of Allotment of Shares****Submit**

Please fill in the following information. Fields marked \* must be completed.

<b>Resolution / Declaration</b>	<b>Share payable in cash</b>	<b>For a consideration other than cash</b>	<b>Share Capital / Allottees Particulars</b>	<b>List of Shareholders after the allotment</b>	<b>Summary of Capital</b>
<b>Share Capital (1)</b>					
Currency :	<b>SINGAPORE DOLLAR (099)</b>				
Nominal Value per Share :	<b>0.10</b>				
Amount of Authorised Share Capital :	<b>200000000.00</b>				
Class of Shares :	Ordinary	Preference	Others		
Amount of Issued Share Capital :	<b>102585812.50</b>	<b>0.00</b>	<b>0.00</b>		
Amount of Paid-up Share Capital :	<b>102585812.50</b>	<b>0.00</b>	<b>0.00</b>		

GST No. :M9-0008879-T

**RECEIPT**

Receipt No : ACR0000000926261A

Date/Time : 04/11/2004 09:25

Transaction  
No : C040503711

Agency : RCB - RCB

Application : BIZFILE PAYMENT SERVICE

Paid via : Deposit Service Account

EP Ref No :

**SINGAPORE AIRPORT TERMINAL SERVICES LIMITED**  
**20 AIRPORT BOULEVARD**  
**SATS INFLIGHT CATERING CENTRE 3**  
**SINGAPORE 819659**

---

<b>Sno Code/Description</b>	<b>Unit Price (S\$)</b>	<b>Qty</b>	<b>Amount</b>
1 Lodgment Of Return Of Allotment Of Share <b>COMPANY/BUSINESS NAME :</b> 197201770G / SINGAPORE AIRPORT TERMINAL SERVICES LIMITED	10.00	1	10.00
<hr/>			
Total (S\$) :			10.00

---

**Deposit Service Account No. : 030066**  
**Balance Amount in Deposit Account : \$ 425.00**

This is a computer-generated receipt. No signature is required.

Please print a copy of the receipt for your reference.

<a href="#">HOME</a>
----------------------

<a href="#">LOGOUT</a>
------------------------

**Return of Allotment of Shares**

Submit

Please fill in the following information. Fields marked \* must be completed.

Resolution/Declaration	Shares payable in cash	For a consideration other than cash	Share Capital/Allottees Particulars	List of Shareholders after the allotment	Summary of Capital
------------------------	---------------------------	---	---	---	-----------------------

Record saved successfully.

**Company Type**

Please click on appropriate button :

- company is listed on the securities exchange  
 company is an unlisted public company  
 company is a private company

**Power under Section 161 of the Companies Act \***

The directors have obtained the approval of the company in  Yes  No general meeting to issue shares.

**Resolution Made**

\* You are only required to fill in this section if the directors are not given the power under Section 161 of the Companies Act to issue shares.

Registration No. : **197201770G**Company Name : **SINGAPORE AIRPORT TERMINAL SERVICES LIMITED**

Nature of Meeting : \* Directors

Place of Meeting : \*

Date of Meeting : \* (dd/mm/yyyy)

Resolution Type : \* Director's

Description : \*  
(max 2000 characters)Attachment : \*  
(copy of resolution)**Note :**

Uploaded file name will be changed by suffixing time-stamp with the actual file name as

**filenameyyyyMMddmmsstt**

Browse...

(Click 'Browse' to select file for attachment)

**Persons signing the resolution**

Please indicate the directors/ secretaries who signed the resolution :

- S0036442H / OW CHIN HOCK
- S0070715E / NG KEE CHOE
- S0234645A / CHEW CHOON SENG
- S1001765C / BARRY HENRY PATRICK DESKER
- S1069567H / TAN JIAK NGEE MICHAEL
- S1673157I / YIP WAI PING ANNABELLE
- S1852301I / HONG HAI @ HUANG HAI
- S2163476Z / CHENG WAI WING EDMUND
- S2580327B / RICHARD CHARLES HELFER

Please enter names of other corporate representatives who signed the resolution, if applicable :

**Declaration**

I, LIM HONG ENG SUSANNA, Professional body/service bureau, declare the information which has been submitted herein to be true to the best of my knowledge.

**Return of Allotment of Shares****Submit**

Please fill in the following information. Fields marked \* must be completed.

Resolution / Declaration	Share payable in cash	For a consideration other than cash	Share Capital / Allottees Particulars	List of Shareholders after the Allotment	Summary of Capital
--------------------------	-----------------------	-------------------------------------	---------------------------------------	--	--------------------

**Authorised Capital**

	Amount	Nominal Value per Share	Currency
Authorised Capital :	<b>20000000</b>	<b>.1</b>	<b>SINGAPORE DOLLAR ( 099 )</b>

Description of discrepancy :

**Return of Allotment of Shares (Payable in cash) \***

Applicable only if share is payable in cash

Class of Shares :	Ordinary	Preference	Others
Number of shares :	18200 /		
Amount paid or due and payable on each share			
paid :	0.10 /		
due and payable :	0 /		
Amount of premium paid or payable on each share :	1.50 /		

**Save****Delete Issued Share****Reset****Back**



**Return of Allotment of Shares****Submit**

Please fill in the following information. Fields marked \* must be completed.

<b>Resolution / Declaration</b>	<b>Share payable in cash</b>	<b>For a consideration other than cash</b>	<b>Share Capital / Allottees Particulars</b>	<b>List of Shareholders after the allotment</b>	<b>Summary of Capital</b>
-------------------------------------	----------------------------------	--	--	---	-------------------------------

**Particulars of Allottee**

Please indicate whether the allottee is an Individual : \*

- Allottee is an Individual  
 Allottee is NOT an Individual

**If Allottee is an Individual :**Shareholder Category : \* **Individual**

Identification No. : \*

**Retrieve Details**

Identification Type : \*

NRIC 

Name : \*

Nationality : \*

Mobile No :

Occupation :

Email Address :

Address Type : \*

- Local  
 Foreign

Local Address (\* if Address Type is Local Address)

Postal Code :

**Retrieve Address**

Block/House No. :

Street Name :

Unit : #

 - 

Building/Estate Name :

Foreign Address (\* if Address Type is Foreign Address)

Address :

  
**If Allottee is NOT an Individual :**

Shareholder Category : \*

Company / Foreign Branch **Search**

Registration No. : \*

198003912M

Retrieve Details

Name :

**THE CENTRAL DEPOSITORY (PTE) LIMITED**

Address Type :

**Local**

Local Address (\* if Address Type is Local Address)

Postal Code : **068804**

Block/House No. : **2**

Street Name : **SHENTON WAY**

Unit : # **19 - 00**

Building/Estate Name : **SGX CENTRE I**

Foreign Address (\* if Address Type is Foreign Address)

Address :

**Details of Shares Allotted** \* Please read instructions carefully before entering.

Note : If any share or shares is/are co-owned by 2 or more persons, please assign an alphabet e.g. A to denote the Group and enter the same in the box. Enter the same alphabet in the box for every allottee in the same group. Skip this box if share(s) are owned by only one person.

Group of Share that is co-owned:  
(Share Group)

If share(s) is/are co-owned, only one allottee is to enter details in (a), (b), (c), (d) and (e). Enter "0" (zero) for subsequent allottees in box (b) and leave blank for rest of the items.

a) Nominal Value per Share :

0.10

b) No. of shares allotted :

18200

c) Class of shares allotted :

Ordinary

d) Currency :

SINGAPORE DOLLAR (099)

e) Date of allotment :

29/10/2004 (dd/mm/yyyy)

Save

Reset

Back

**Return of Allotment of Shares****Submit**

Please fill in the following information. Fields marked \* must be completed.

<b>Resolution / Declaration</b>	<b>Share payable in cash</b>	<b>For a consideration other than cash</b>	<b>Share Capital / Allottees Particulars</b>	<b>List of Shareholders after Allotment</b>	<b>Summary of Capital</b>
-------------------------------------	----------------------------------	--	--	---	-------------------------------

**List of Allottees and their particulars****Identification****No./Registration Name  
No.****Shareholder Category**

198003912M	THE CENTRAL DEPOSITORY (PTE) LIMITED	Company / Foreign Branch
------------	---	--------------------------

If No. of shareholders exceeds 50, total No. of issued shares held by the remaining shareholders are :

<b>No. of Shares</b>	<b>Ordinary</b>	<b>Preference</b>	<b>Others</b>
	0	0	0

**Return of Allotment of Shares****Submit**

Please fill in the following information. Fields marked \* must be completed.

<u>Resolution / Declaration</u>	<u>Share payable in cash</u>	<u>For a consideration other than cash</u>	<u>Share Capital / Allottees Particulars</u>	<u>List of Shareholders after the allotment</u>	<u>Summary of Capital</u>
---------------------------------	------------------------------	--	--	---	---------------------------

**Share Capital (1)**

Currency :	<b>SINGAPORE DOLLAR (099)</b>		
Nominal Value per Share :	<b>0.10</b>		
Amount of Authorised Share Capital :	<b>200000000.00</b>		
Class of Shares :	Ordinary	Preference	Others
Amount of Issued Share Capital :	<b>102581867.50</b>	<b>0.00</b>	<b>0.00</b>
Amount of Paid-up Share Capital :	<b>102581867.50</b>	<b>0.00</b>	<b>0.00</b>

GST No. :M9-0008879-T

**RECEIPT**

Receipt No : ACR0000000926251A

Date/Time : 04/11/2004 09:19

Transaction No : C040503702

Agency : RCB - RCB

Application : BIZFILE PAYMENT SERVICE

Paid via : Deposit Service Account

EP Ref No :

**SINGAPORE AIRPORT TERMINAL SERVICES LIMITED**  
**20 AIRPORT BOULEVARD**  
**SATS INFLIGHT CATERING CENTRE 3**  
**SINGAPORE 819659**

---

<b>Sno Code/Description</b>	<b>Unit Price (S\$)</b>	<b>Qty</b>	<b>Amount</b>
1 Lodgment Of Return Of Allotment Of Share <b>COMPANY/BUSINESS NAME :</b> 197201770G / SINGAPORE AIRPORT TERMINAL SERVICES LIMITED	10.00	1	10.00
<b>Total (S\$) :</b>			<b>10.00</b>

---

**Deposit Service Account No. : 030066**  
**Balance Amount in Deposit Account : \$ 435.00**

This is a computer-generated receipt. No signature is required.

Please print a copy of the receipt for your reference.

[HOME](#)[LOGOUT](#)

**Return of Allotment of Shares**

Submit

Please fill in the following information. Fields marked \* must be completed.

Resolution/Declaration	Shares payable in cash	For a consideration other than cash	Share Capital/Allottees Particulars	List of Shareholders after the allotment	Summary of Capital
------------------------	---------------------------	---	---	---	-----------------------

**Record saved successfully.****Company Type**

Please click on appropriate button :

- company is listed on the securities exchange
- company is an unlisted public company
- company is a private company

**Power under Section 161 of the Companies Act \***

The directors have obtained  
the approval of the company in  Yes  
general meeting to issue  No  
shares.

**Resolution Made**

\* You are only required to fill in this section if the directors are not given the power under Section 161 of the Companies Act to issue shares.

Registration No. : **197201770G**Company Name : **SINGAPORE AIRPORT TERMINAL SERVICES LIMITED**Nature of Meeting : \* Directors 

Place of Meeting : \*

Date of Meeting : \*  (dd/mm/yyyy)Resolution Type : \* Director's Description : \*  
(max 2000 characters)
Attachment : \*  
(copy of resolution)**Note :**

Uploaded file name will be  
changed by suffixing time-  
stamp with the actual file  
name as

filenameyyyyMMddmmsstt

 Browse...

(Click 'Browse' to select file for attachment)

**Persons signing the resolution**

Please indicate the directors/ secretaries who signed the resolution :

- S0036442H / OW CHIN HOCK
- S0070715E / NG KEE CHOE
- S0234645A / CHEW CHOON SENG
- S1001765C / BARRY HENRY PATRICK DESKER
- S1069567H / TAN JIAK NGEE MICHAEL
- S1673157I / YIP WAI PING ANNABELLE
- S1852301I / HONG HAI @ HUANG HAI
- S2163476Z / CHENG WAI WING EDMUND
- S2580327B / RICHARD CHARLES HELFER

Please enter names of other corporate representatives who signed the resolution, if applicable :

**Declaration**

I, LIM HONG ENG SUSANNA, Professional body/service bureau, declare the information which has been submitted herein to be true to the best of my knowledge.

**Return of Allotment of Shares**

Please fill in the following information. Fields marked \* must be completed.

Resolution / Declaration	Share payable in cash	For a consideration other than cash	Share Capital / Allottees Particulars	List of Shareholders after the Allotment	Summary of Capital
<b>Authorised Capital</b>					
	Amount		Nominal Value per Share	Currency	
Authorised Capital :	<b>200000000</b>		<b>.1</b>	<b>SINGAPORE DOLLAR ( 099 )</b>	

Description of discrepancy :

**Return of Allotment of Shares (Payable in cash) \***

Applicable only if share is payable in cash

Class of Shares :	Ordinary	Preference	Others
Number of shares :	<input type="text" value="5200"/>	<input type="text"/>	<input type="text"/>
Amount paid or due and payable on each share			
paid :	<input type="text" value="0.10"/>	<input type="text"/>	<input type="text"/>
due and payable :	<input type="text" value="0"/>	<input type="text"/>	<input type="text"/>
Amount of premium paid or payable on each share :	<input type="text" value="1.14"/>	<input type="text"/>	<input type="text"/>



**Return of Allotment of Shares****Submit**

Please fill in the following information. Fields marked \* must be completed.

<u>Resolution / Declaration</u>	<u>Share payable in cash</u>	<u>For a consideration other than cash</u>	<u>Share Capital / Allottees Particulars</u>	<u>List of Shareholders after the allotment</u>	<u>Summary of Capital</u>
-------------------------------------	----------------------------------	--	--	---	-------------------------------

**Particulars of Allottee****Please indicate whether the allottee is an Individual : \***

- Allottee is an Individual  
 Allottee is NOT an Individual

**If Allottee is an Individual :**Shareholder Category : \* **Individual**

Identification No. : \*

**Retrieve Details**

Identification Type : \*

NRIC 

Name : \*

Nationality : \*

Mobile No. :

Occupation :

Email Address :

Address Type : \*

- Local  
 Foreign

Local Address (\* if Address Type is Local Address)

Postal Code :

**Retrieve Address**

Block/House No. :

Street Name :

Unit : #

 - 

Building/Estate Name :

Foreign Address (\* if Address Type is Foreign Address)

Address :

  
**If Allottee is NOT an Individual :**

Shareholder Category : \*

Company / Foreign Branch **Search**

Registration No. : **THE CENTRAL DEPOSITORY (PTE) LIMITED**

Address Type : **Local**

Local Address (\* if Address Type is Local Address)

Postal Code : **068804**

Block/House No. : **2**

Street Name : **SHENTON WAY**

Unit : # **19 - 00**

Building/Estate Name : **SGX CENTRE I**

Foreign Address (\* if Address Type is Foreign Address)

Address :

**Details of Shares Allotted** \* Please read instructions carefully before entering.

Note : If any share or shares is/are co-owned by 2 or more persons, please assign an alphabet e.g. A to denote the Group and enter the same in the box. Enter the same alphabet in the box for every allottee in the same group. Skip this box if share(s) are owned by only one person.

Group of Share that is co-owned:  
(Share Group)

If share(s) is/are co-owned, only one allottee is to enter details in (a), (b), (c), (d) and (e). Enter "0" (zero) for subsequent allottees in box (b) and leave blank for rest of the items.

a) Nominal Value per Share :

b) No. of shares allotted :

c) Class of shares allotted :

d) Currency :

e) Date of allotment :  (dd/mm/yyyy)

**Return of Allotment of Shares**

Please fill in the following information. Fields marked \* must be completed.

<b>Resolution / Declaration</b>	<b>Share payable in cash</b>	<b>For a consideration other than cash</b>	<b>Share Capital / Allottees Particulars</b>	<b>List of Shareholders after Allotment</b>	<b>Summary of Capital</b>
-------------------------------------	----------------------------------	--	--	---	-------------------------------

**List of Allottees and their particulars****Identification****No./Registration Name  
No.****Shareholder Category**

198003912M	THE CENTRAL DEPOSITORY (PTE) LIMITED	Company / Foreign Branch
------------	---	--------------------------

If No. of shareholders exceeds 50, total No. of issued shares held by the remaining shareholders are :

	<b>Ordinary</b>	<b>Preference</b>	<b>Others</b>
<b>No. of Shares</b>	<b>0</b>	<b>0</b>	<b>0</b>

**Return of Allotment of Shares**

**Submit**

Please fill in the following information. Fields marked \* must be completed.

Resolution / Declaration	Share payable in cash	For a consideration other than cash	Share Capital / Allottees Particulars	List of Shareholders after the allotment	Summary of Capital
--------------------------	-----------------------	-------------------------------------	---------------------------------------	--	--------------------

**Share Capital (1)**

Currency :	<b>SINGAPORE DOLLAR (099)</b>		
Nominal Value per Share :	<b>0.10</b>		
Amount of Authorised Share Capital :	<b>200000000.00</b>		
Class of Shares :	Ordinary	Preference	Others
Amount of Issued Share Capital :	<b>102580047.50</b>	<b>0.00</b>	<b>0.00</b>
Amount of Paid-up Share Capital :	<b>102580047.50</b>	<b>0.00</b>	<b>0.00</b>

GST No. :M9-0008879-T

**RECEIPT**

Receipt No : ACR0000000922759A  
Transaction No : C040500062  
Agency : RCB - RCB  
Application : BIZFILE PAYMENT SERVICE  
Paid via : Deposit Service Account  
EP Ref No :

Date/Time : 02/11/2004 10:32

**SINGAPORE AIRPORT TERMINAL SERVICES LIMITED**  
**20 AIRPORT BOULEVARD**  
**SATS INFLIGHT CATERING CENTRE 3**  
**SINGAPORE 819659**

---

<b>Sno Code/Description</b>	<b>Unit Price (S\$)</b>	<b>Qty</b>	<b>Amount</b>
1 Lodgment Of Return Of Allotment Of Share <b>COMPANY/BUSINESS NAME :</b> 197201770G / SINGAPORE AIRPORT TERMINAL SERVICES LIMITED	10.00	1	10.00
<b>Total (S\$) :</b>			<b>10.00</b>

---

**Deposit Service Account No. : 030066**  
**Balance Amount in Deposit Account : \$ 445.00**

This is a computer-generated receipt. No signature is required.

Please print a copy of the receipt for your reference.

[HOME](#)[LOGOUT](#)

**Return of Allotment of Shares****Submit**

Please fill in the following information. Fields marked \* must be completed.

Resolution/Declaration	Shares payable in cash	For a consideration other than cash	Share Capital/Allottees Particulars	List of Shareholders after the allotment	Summary of Capital
------------------------	---------------------------	---	---	---	-----------------------

**Record saved successfully.****Company Type**

Please click on appropriate button :

- company is listed on the securities exchange  
 company is an unlisted public company  
 company is a private company

**Power under Section 161 of the Companies Act \***

The directors have obtained the approval of the company in general meeting to issue shares.

Yes  
 No

**Resolution Made**

\* You are only required to fill in this section if the directors are not given the power under Section 161 of the Companies Act to issue shares.

Registration No. : **197201770G**Company Name : **SINGAPORE AIRPORT TERMINAL SERVICES LIMITED**Nature of Meeting : \* **Directors**

Place of Meeting : \*

Date of Meeting: \* (dd/mm/yyyy)

Resolution Type : \* **Director's**Description : \*  
(max 2000 characters)Attachment : \*  
(copy of resolution)**Note :**

Uploaded file name will be changed by suffixing time-stamp with the actual file name as

**filenameyyyyMMdmsstt****Browse...**

(Click 'Browse' to select file for attachment)

**Persons signing the resolution**

Please indicate the directors/ secretaries who signed the resolution :

- S0036442H / OW CHIN HOCK
- S0070715E / NG KEE CHOE
- S0234645A / CHEW CHOON SENG
- S1001765C / BARRY HENRY PATRICK DESKER
- S1069567H / TAN JIAK NGEE MICHAEL
- S1673157I / YIP WAI PING ANNABELLE
- S1852301I / HONG HAI @ HUANG HAI
- S2163476Z / CHENG WAI WING EDMUND
- S2580327B / RICHARD CHARLES HELFER

Please enter names of other corporate representatives who signed the resolution, if applicable :

**Declaration**

I, LIM HONG ENG SUSANNA, Professional body/service bureau, declare the information which has been submitted herein to be true to the best of my knowledge.

**Return of Allotment of Shares**

Submit

Please fill in the following information. Fields marked \* must be completed.

<u>Resolution / Declaration</u>	<u>Share payable in cash</u>	<u>For a consideration other than cash</u>	<u>Share Capital / Allottees Particulars</u>	<u>List of Shareholders after the Allotment</u>	<u>Summary of Capital</u>
-------------------------------------	----------------------------------	--	--	---	-------------------------------

**Authorised Capital**

	Amount	Nominal Value per Share	Currency
Authorised Capital :	<b>200000000</b>	<b>.1</b>	<b>SINGAPORE DOLLAR ( 099 )</b>

Description of discrepancy :

**Return of Allotment of Shares (Payable in cash) \***

Applicable only if share is payable in cash

Class of Shares :	Ordinary	Preference	Others
Number of shares :	<input type="text" value="2600"/>	<input type="text"/>	<input type="text"/>
Amount paid or due and payable on each share			
paid :	<input type="text" value="0.10"/>	<input type="text"/>	<input type="text"/>
due and payable :	<input type="text" value="0"/>	<input type="text"/>	<input type="text"/>
Amount of premium paid or payable on each share :	<input type="text" value="1.50"/>	<input type="text"/>	<input type="text"/>

Save

Delete Issued Share

Reset

Back



**Return of Allotment of Shares****Submit**

Please fill in the following information. Fields marked \* must be completed.

Resolution / Declaration	Share payable in cash	For a consideration other than cash	Share Capital / Allottees Particulars	List of Shareholders after the allotment	Summary of Capital
--------------------------	-----------------------	-------------------------------------	---------------------------------------	--	--------------------

**Particulars of Allottee**

Please indicate whether the allottee is an Individual : \*

- Allottee is an Individual  
 Allottee is NOT an Individual ✓

If Allottee is an Individual :

Shareholder Category : \* **Individual**Identification No. : \*  **Retrieve Details**Identification Type : \* Name : \* Nationality : \* Mobile No : Occupation : Email Address : 

Address Type : \*

Local  
 Foreign

Local Address (\* if Address Type is Local Address)

Postal Code :  **Retrieve Address**Block/House No. : Street Name : Unit : #  - Building/Estate Name : 

Foreign Address (\* if Address Type is Foreign Address)

Address : 

If Allottee is NOT an Individual :

Shareholder Category : \*  **Search**

Name : THE CENTRAL DEPOSITORY (PTE) LIMITED

Address Type : Local

Local Address (\* if Address Type is Local Address)

Postal Code : 068804

Block/House No. : 2

Street Name : SHENTON WAY

Unit : # 19 - 00

Building/Estate Name : SGX CENTRE I

Foreign Address (\* if Address Type is Foreign Address)

Address :

**Details of Shares Allotted** \* Please read instructions carefully before entering.

Note : If any share or shares is/are co-owned by 2 or more persons, please assign an alphabet e.g. A to denote the Group and enter the same in the box. Enter the same alphabet in the box for every allottee in the same group. Skip this box if share(s) are owned by only one person.

Group of Share that is co-owned:   
(Share Group)

If share(s) is/are co-owned, only one allottee is to enter details in (a), (b), (c), (d) and (e). Enter "0" (zero) for subsequent allottees in box (b) and leave blank for rest of the items.

a) Nominal Value per Share :

b) No. of shares allotted :

c) Class of shares allotted :

d) Currency :

e) Date of allotment :  (dd/mm/yyyy)

**Return of Allotment of Shares****Submit**

Please fill in the following information. Fields marked \* must be completed.

<b>Resolution / Declaration</b>	<b>Share payable in cash</b>	<b>For a consideration other than cash</b>	<b>Share Capital / Allottees Particulars</b>	<b>List of Shareholders after Allotment</b>	<b>Summary of Capital</b>
-------------------------------------	----------------------------------	--	--	---	-------------------------------

**List of Allottees and their particulars****Identification****No./Registration Name  
No.****Shareholder Category**

198003912M	THE CENTRAL DEPOSITORY (PTE) LIMITED	Company / Foreign Branch
------------	---	--------------------------

If No. of shareholders exceeds 50, total No. of issued shares held by the remaining shareholders are :

<b>No. of Shares</b>	<b>Ordinary</b>	<b>Preference</b>	<b>Others</b>
	0	0	0

**Return of Allotment of Shares****Submit**

Please fill in the following information. Fields marked \* must be completed.

<u>Resolution / Declaration</u>	<u>Share payable in cash</u>	<u>For a consideration other than cash</u>	<u>Share Capital / Allottees Particulars</u>	<u>List of Shareholders after the allotment</u>	<u>Summary of Capital</u>
<b>Share Capital (1)</b>					
Currency :	<b>SINGAPORE DOLLAR (099)</b>				
Nominal Value per Share :	<b>0.10</b>				
Amount of Authorised Share Capital :	<b>200000000.00</b>				
Class of Shares :	Ordinary	Preference	Others		
Amount of Issued Share Capital :	<b>102579527.50</b>	<b>0.00</b>	<b>0.00</b>		
Amount of Paid-up Share Capital :	<b>102579527.50</b>	<b>0.00</b>	<b>0.00</b>		

**RECEIPT**

Receipt No : ACR0000000922745A  
Transaction No : C040500049  
Agency : RCB - RCB  
Application : BIZFILE PAYMENT SERVICE  
Paid via : Deposit Service Account  
EP Ref No :

Date/Time : 02/11/2004 10:26

**SINGAPORE AIRPORT TERMINAL SERVICES LIMITED  
20 AIRPORT BOULEVARD  
SATS INFLIGHT CATERING CENTRE 3  
SINGAPORE 819659**

---

<b>Sno Code/Description</b>	<b>Unit Price (S\$)</b>	<b>Qty</b>	<b>Amount</b>
1 Lodgment Of Return Of Allotment Of Share <b>COMPANY/BUSINESS NAME :</b> 197201770G / SINGAPORE AIRPORT TERMINAL SERVICES LIMITED	10.00	1	10.00
<b>Total (S\$) :</b>			<b>10.00</b>

---

**Deposit Service Account No. : 030066**  
**Balance Amount in Deposit Account : \$ 455.00**

This is a computer-generated receipt. No signature is required.

Please print a copy of the receipt for your reference.

<a href="#">HOME</a>	<a href="#">LOGOUT</a>
----------------------	------------------------

**Return of Allotment of Shares****Submit**

Please fill in the following information. Fields marked \* must be completed.

Resolution/Declaration	Shares payable in cash	For a consideration other than cash	Share Capital/Allottees Particulars	List of Shareholders after the allotment	Summary of Capital
------------------------	---------------------------	---	---	---	-----------------------

**Record saved successfully.****Company Type**

Please click on appropriate button :

- company is listed on the securities exchange  
 company is an unlisted public company  
 company is a private company

**Power under Section 161 of the Companies Act \***

The directors have obtained the approval of the company in  Yes  
 general meeting to issue  No shares.

**Resolution Made**

\* You are only required to fill in this section if the directors are not given the power under Section 161 of the Companies Act to issue shares.

Registration No. : **197201770G**Company Name : **SINGAPORE AIRPORT TERMINAL SERVICES LIMITED**Nature of Meeting : \* 

Place of Meeting : \*

Date of Meeting : \*  (dd/mm/yyyy)Resolution Type : \* Description : \*  
(max 2000 characters)Attachment : \*  
(copy of resolution)**Note :**

Uploaded file name will be changed by suffixing time-stamp with the actual file name as

filenameyyyyMMddmmsstt

**Browse...**

(Click 'Browse' to select file for attachment)

**Persons signing the resolution**

Please indicate the directors/ secretaries who signed the resolution :

- S0036442H / OW CHIN HOCK
- S0070715E / NG KEE CHOE
- S0234645A / CHEW CHOON SENG
- S1001765C / BARRY HENRY PATRICK DESKER
- S1069567H / TAN JIAK NGEE MICHAEL
- S1673157I / YIP WAI PING ANNABELLE
- S1852301I / HONG HAI @ HUANG HAI
- S2163476Z / CHENG WAI WING EDMUND
- S2580327B / RICHARD CHARLES HELFER

Please enter names of other corporate representatives who signed the resolution, if applicable :

**Declaration**

I, LIM HONG ENG SUSANNA, Professional body/service bureau, declare the information which has been submitted herein to be true to the best of my knowledge.

**Return of Allotment of Shares****Submit**

Please fill in the following information. Fields marked \* must be completed.

<b>Resolution / Declaration</b>	<b>Share payable in cash</b>	<b>For a consideration other than cash</b>	<b>Share Capital / Allottees Particulars</b>	<b>List of Shareholders after the Allotment</b>	<b>Summary of Capital</b>
-------------------------------------	----------------------------------	--	--	---	-------------------------------

**Authorised Capital**

	<b>Amount</b>	<b>Nominal Value per Share</b>	<b>Currency</b>
Authorised Capital :	<b>200000000</b>	<b>.1</b>	<b>SINGAPORE DOLLAR ( 099 )</b>

Description of discrepancy :

**Return of Allotment of Shares (Payable in cash) \***

Applicable only if share is payable in cash

<b>Class of Shares :</b>	<b>Ordinary</b>	<b>Preference</b>	<b>Others</b>
Number of shares :	<input type="text" value="2600"/>	<input type="text"/>	<input type="text"/>
Amount paid or due and payable on each share			
paid :	<input type="text" value="0.10"/>	<input type="text"/>	<input type="text"/>
due and payable :	<input type="text" value="0"/>	<input type="text"/>	<input type="text"/>
Amount of premium paid or payable on each share :	<input type="text" value="1.14"/>	<input type="text"/>	<input type="text"/>

<b>Save</b>	<b>Delete Issued Share</b>	<b>Reset</b>	<b>Back</b>
-------------	----------------------------	--------------	-------------



**Return of Allotment of Shares****Submit**

Please fill in the following information. Fields marked \* must be completed.

Resolution / Declaration	Share payable in cash	For a consideration other than cash	Share Capital / Allottees Particulars	List of Shareholders after the allotment	Summary of Capital
--------------------------	-----------------------	-------------------------------------	---------------------------------------	--	--------------------

**Particulars of Allottee**

Please indicate whether the allottee is an Individual : \*

- Allottee is an Individual  
 Allottee is NOT an Individual

If Allottee is an Individual :

Shareholder Category : \* **Individual**Identification No. : \*  **Retrieve Details**Identification Type : \* Name : \* Nationality : \* Mobile No : Occupation : Email Address : 

Address Type : \*

Local  
 Foreign

Local Address (\* if Address Type is Local Address)

Postal Code :  **Retrieve Address**Block/House No. : 

Street Name :

Unit : #  - 

Building/Estate Name :

Foreign Address (\* if Address Type is Foreign Address)

Address : 

If Allottee is NOT an Individual :

Shareholder Category : \*  **Search**

Registration No. : \*

198003912M

Retrieve Details

Name :

**THE CENTRAL DEPOSITORY (PTE) LIMITED**

Address Type :

**Local**

Local Address (\* if Address Type is Local Address)

Postal Code : **068804**

Block/House No. : **2**

Street Name : **SHENTON WAY**

Unit : # **19 - 00**

Building/Estate Name : **SGX CENTRE I**

Foreign Address (\* if Address Type is Foreign Address)

Address :

**Details of Shares Allotted** \* Please read instructions carefully before entering.

Note : If any share or shares is/are co-owned by 2 or more persons, please assign an alphabet e.g. A to denote the Group and enter the same in the box. Enter the same alphabet in the box for every allottee in the same group. Skip this box if share(s) are owned by only one person.

Group of Share that is co-owned:  
(Share Group)

If share(s) is/are co-owned, only one allottee is to enter details in (a), (b), (c), (d) and (e). Enter "0" (zero) for subsequent allottees in box (b) and leave blank for rest of the items.

a) Nominal Value per Share :

0.10

b) No. of shares allotted :

2600

c) Class of shares allotted :

Ordinary

d) Currency :

SINGAPORE DOLLAR (099)

e) Date of allotment :

28/10/2004 (dd/mm/yyyy)

Save

Reset

Back

**Return of Allotment of Shares****Submit**

Please fill in the following information. Fields marked \* must be completed.

<b>Resolution / Declaration</b>	<b>Share payable in cash</b>	<b>For a consideration other than cash</b>	<b>Share Capital / Allottees Particulars</b>	<b>List of Shareholders after Allotment</b>	<b>Summary of Capital</b>
-------------------------------------	----------------------------------	--	--	---	-------------------------------

**List of Allottees and their particulars****Identification****No./Registration Name  
No.****Shareholder Category**

198003912M	THE CENTRAL DEPOSITORY (PTE) LIMITED	Company / Foreign Branch
------------	---	--------------------------

If No. of shareholders exceeds 50, total No. of issued shares held by the remaining shareholders are :

	<b>Ordinary</b>	<b>Preference</b>	<b>Others</b>
<b>No. of Shares</b>	<b>0</b>	<b>0</b>	<b>0</b>

**Return of Allotment of Shares**

**Submit**

Please fill in the following information. Fields marked \* must be completed.

Resolution / Declaration	Share payable in cash	For a consideration other than cash	Share Capital / Allottees Particulars	List of Shareholders after the allotment	Summary of Capital
<b>Share Capital (1)</b>					
Currency :	<b>SINGAPORE DOLLAR (099)</b>				
Nominal Value per Share :	<b>0.10</b>				
Amount of Authorised Share Capital :	<b>200000000.00</b>				
Class of Shares :	Ordinary	Preference	Others		
Amount of Issued Share Capital :	<b>102579267.50</b>	<b>0.00</b>	<b>0.00</b>		
Amount of Paid-up Share Capital :	<b>102579267.50</b>	<b>0.00</b>	<b>0.00</b>		

GST No. :M9-0008879-T

**RECEIPT**

Receipt No : ACR0000000922706A

Date/Time : 02/11/2004 10:16

Transaction  
No : C040500014

Agency : RCB - RCB

Application : BIZFILE PAYMENT SERVICE

Paid via : Deposit Service Account

EP Ref No :

**SINGAPORE AIRPORT TERMINAL SERVICES LIMITED  
20 AIRPORT BOULEVARD  
SATS INFLIGHT CATERING CENTRE 3  
SINGAPORE 819659**

<b>Sno Code/Description</b>	<b>Unit Price (S\$)</b>	<b>Qty</b>	<b>Amount</b>
1 Lodgment Of Return Of Allotment Of Share <b>COMPANY/BUSINESS NAME :</b> 197201770G / SINGAPORE AIRPORT TERMINAL SERVICES LIMITED	10.00	1	10.00
<b>Total (S\$) :</b>			<b>10.00</b>

**Deposit Service Account No. : 030066**  
**Balance Amount in Deposit Account : \$ 465.00**

This is a computer-generated receipt. No signature is required.

Please print a copy of the receipt for your reference.

[HOME](#)[LOGOUT](#)

## Return of Allotment of Shares

Submit

Please fill in the following information. Fields marked \* must be completed.

Resolution/Declaration	Shares payable in cash	For a consideration other than cash	Share Capital/Allottees Particulars	List of Shareholders after the allotment	Summary of Capital
------------------------	---------------------------	---	---	---	-----------------------

Record saved successfully.

## Company Type

Please click on appropriate button :

- company is listed on the securities exchange  
 company is an unlisted public company  
 company is a private company

## Power under Section 161 of the Companies Act \*

The directors have obtained the approval of the company in general meeting to issue shares.

Yes  
 No

## Resolution Made

\* You are only required to fill in this section if the directors are not given the power under Section 161 of the Companies Act to issue shares.

Registration No. : 197201770G

Company Name : SINGAPORE AIRPORT TERMINAL SERVICES LIMITED

Nature of Meeting : \* Directors

Place of Meeting : \*

Date of Meeting : \* (dd/mm/yyyy)

Resolution Type : \* Director's

Description : \*  
(max 2000 characters)Attachment : \*  
(copy of resolution)

## Note :

Uploaded file name will be changed by suffixing time-stamp with the actual file name as

filenameyyyyMMddmmsstt

Browse...

(Click 'Browse' to select file for attachment)

**Persons signing the resolution**

Please indicate the directors/ secretaries who signed the resolution :

- S0036442H / OW CHIN HOCK
- S0070715E / NG KEE CHOE
- S0234645A / CHEW CHOON SENG
- S1001765C / BARRY HENRY PATRICK DESKER
- S1069567H / TAN JIAK NGEE MICHAEL
- S1673157I / YIP WAI PING ANNABELLE
- S1852301I / HONG HAI @ HUANG HAI
- S2163476Z / CHENG WAI WING EDMUND
- S2580327B / RICHARD CHARLES HELFER

Please enter names of other corporate representatives who signed the resolution, if applicable :

**Declaration**

I, LIM HONG ENG SUSANNA, Professional body/service bureau, declare the information which has been submitted herein to be true to the best of my knowledge.

**Return of Allotment of Shares****Submit**

Please fill in the following information. Fields marked \* must be completed.

<b>Resolution / Declaration</b>	<b>Share payable in cash</b>	<b>For a consideration other than cash</b>	<b>Share Capital / Allottees Particulars</b>	<b>List of Shareholders after the Allotment</b>	<b>Summary of Capital</b>
-------------------------------------	----------------------------------	--	--	---	-------------------------------

**Authorised Capital**

	<b>Amount</b>	<b>Nominal Value per Share</b>	<b>Currency</b>
Authorised Capital :	<b>20000000</b>	<b>.1</b>	<b>SINGAPORE DOLLAR ( 099 )</b>

Description of discrepancy :

**Return of Allotment of Shares (Payable in cash) \***

Applicable only if share is payable in cash

<b>Class of Shares :</b>	<b>Ordinary</b>	<b>Preference</b>	<b>Others</b>
Number of shares :	<input type="text" value="2600"/>	<input type="text"/>	<input type="text"/>
Amount paid or due and payable on each share			
paid :	<input type="text" value="0.10"/>	<input type="text"/>	<input type="text"/>
due and payable :	<input type="text" value="0"/>	<input type="text"/>	<input type="text"/>
Amount of premium paid or payable on each share :	<input type="text" value="1.70"/>	<input type="text"/>	<input type="text"/>

<b>Save</b>	<b>Delete Issued Share</b>	<b>Reset</b>	<b>Back</b>
-------------	----------------------------	--------------	-------------



**Return of Allotment of Shares****Submit**

Please fill in the following information. Fields marked \* must be completed.

Resolution / Declaration	Share payable in cash	For a consideration other than cash	Share Capital / Allottees Particulars	List of Shareholders after the allotment	Summary of Capital
--------------------------	-----------------------	-------------------------------------	---------------------------------------	--	--------------------

**Particulars of Allottee**

Please indicate whether the allottee is an Individual : \*

- Allottee is an Individual  
 Allottee is NOT an Individual

If Allottee is an Individual :

Shareholder Category : \* **Individual**Identification No. : \*  **Retrieve Details**Identification Type : \* Name : \* Nationality : \* Mobile No : Occupation : Email Address : Address Type : \*  
 Local  
 Foreign

Local Address (\* if Address Type is Local Address)

Postal Code :  **Retrieve Address**Block/House No. : Street Name : Unit : #  - Building/Estate Name : 

Foreign Address (\* if Address Type is Foreign Address)

Address : 

If Allottee is NOT an Individual :

Shareholder Category : \*  **Search**

Registration No. : \*

198003912M

Retrieve Details

Name :

**THE CENTRAL DEPOSITORY (PTE) LIMITED**

Address Type :

**Local**

Local Address (\* if Address Type is Local Address)

Postal Code : **068804**

Block/House No. : **2**

Street Name : **SHENTON WAY**

Unit : # **19 - 00**

Building/Estate Name : **SGX CENTRE I**

Foreign Address (\* if Address Type is Foreign Address)

Address :

**Details of Shares Allotted** \* Please read instructions carefully before entering.

Note : If any share or shares is/are co-owned by 2 or more persons, please assign an alphabet e.g. A to denote the Group and enter the same in the box. Enter the same alphabet in the box for every allottee in the same group. Skip this box if share(s) are owned by only one person.

Group of Share that is co-owned:  
(Share Group)

If share(s) is/are co-owned, only one allottee is to enter details in (a), (b), (c), (d) and (e). Enter "0" (zero) for subsequent allottees in box (b) and leave blank for rest of the items.

a) Nominal Value per Share :

b) No. of shares allotted :

c) Class of shares allotted :

d) Currency :

e) Date of allotment :

 (dd/mm/yyyy)

**Return of Allotment of Shares****Submit**

Please fill in the following information. Fields marked \* must be completed.

<b>Resolution / Declaration</b>	<b>Share payable in cash</b>	<b>For a consideration other than cash</b>	<b>Share Capital / Allottees Particulars</b>	<b>List of Shareholders after Allotment</b>	<b>Summary of Capital</b>
-------------------------------------	----------------------------------	--	--	---	-------------------------------

**List of Allottees and their particulars****Identification****No./Registration Name  
No.****Shareholder Category**

198003912M	THE CENTRAL DEPOSITORY (PTE) LIMITED	Company / Foreign Branch
------------	---	--------------------------

If No. of shareholders exceeds 50, total No. of issued shares held by the remaining shareholders are :

	<b>Ordinary</b>	<b>Preference</b>	<b>Others</b>
<b>No. of Shares</b>	<b>0</b>	<b>0</b>	<b>0</b>

**Return of Allotment of Shares****Submit**

Please fill in the following information. Fields marked \* must be completed.

<u>Resolution / Declaration</u>	<u>Share payable in cash</u>	<u>For a consideration other than cash</u>	<u>Share Capital / Allottees Particulars</u>	<u>List of Shareholders after the allotment</u>	<u>Summary of Capital</u>
<b>Share Capital (1)</b>					
Currency :	<b>SINGAPORE DOLLAR (099)</b>				
Nominal Value per Share :	<b>0.10</b>				
Amount of Authorised Share Capital :	<b>200000000.00</b>				
Class of Shares :	Ordinary	Preference	Others		
Amount of Issued Share Capital :	<b>102579007.50</b>	<b>0.00</b>	<b>0.00</b>		
Amount of Paid-up Share Capital :	<b>102579007.50</b>	<b>0.00</b>	<b>0.00</b>		

**RECEIPT**

Receipt No : ACR000000920726A  
Transaction No : C040497839  
Agency : RCB - RCB  
Application : BIZFILE PAYMENT SERVICE  
Paid via : Deposit Service Account  
EP Ref No :

Date/Time : 01/11/2004 09:11

**SINGAPORE AIRPORT TERMINAL SERVICES LIMITED**  
**20 AIRPORT BOULEVARD**  
**SATS INFLIGHT CATERING CENTRE 3**  
**SINGAPORE 819659**

---

<b>Sno Code/Description</b>	<b>Unit Price (S\$)</b>	<b>Qty</b>	<b>Amount</b>
1 Lodgment Of Return Of Allotment Of Share <b>COMPANY/BUSINESS NAME :</b> 197201770G / SINGAPORE AIRPORT TERMINAL SERVICES LIMITED	10.00	1	10.00
<b>Total (S\$) :</b>			<b>10.00</b>

---

**Deposit Service Account No. : 030066**  
**Balance Amount in Deposit Account : \$ 505.00**

This is a computer-generated receipt. No signature is required.

Please print a copy of the receipt for your reference.

[HOME](#)[LOGOUT](#)

**Return of Allotment of Shares****Submit**

Please fill in the following information. Fields marked \* must be completed.

Resolution/Declaration	Shares payable in cash	For a consideration other than cash	Share Capital/Allottees Particulars	List of Shareholders after the allotment	Summary of Capital
------------------------	---------------------------	---	---	---	-----------------------

**Record saved successfully.****Company Type**

Please click on appropriate button :

- company is listed on the securities exchange  
 company is an unlisted public company  
 company is a private company

**Power under Section 161 of the Companies Act \***

The directors have obtained the approval of the company in general meeting to issue shares.

Yes  
 No

**Resolution Made**

\* You are only required to fill in this section if the directors are not given the power under Section 161 of the Companies Act to issue shares.

Registration No. : **197201770G**Company Name : **SINGAPORE AIRPORT TERMINAL SERVICES LIMITED**Nature of Meeting : \* **Directors**

Place of Meeting : \*

Date of Meeting : \* (dd/mm/yyyy)

Resolution Type : \* **Director's**Description : \*  
(max 2000 characters)Attachment : \*  
(copy of resolution)**Note :**

Uploaded file name will be changed by suffixing time-stamp with the actual file name as

**filenameyyyyMMddmmsstt****Browse...**

(Click 'Browse' to select file for attachment)

**Persons signing the resolution**

Please indicate the directors/ secretaries who signed the resolution :

- S0036442H / OW CHIN HOCK
- S0070715E / NG KEE CHOE
- S0234645A / CHEW CHOON SENG
- S1001765C / BARRY HENRY PATRICK DESKER
- S1069567H / TAN JIAK NGEE MICHAEL
- S1673157I / YIP WAI PING ANNABELLE
- S1852301I / HONG HAI @ HUANG HAI
- S2163476Z / CHENG WAI WING EDMUND
- S2580327B / RICHARD CHARLES HELFER

Please enter names of other corporate representatives who signed the resolution, if applicable :

**Declaration**

I, LIM HONG ENG SUSANNA, Professional body/service bureau, declare the information which has been submitted herein to be true to the best of my knowledge.

**Return of Allotment of Shares**[Submit](#)

Please fill in the following information. Fields marked \* must be completed.

Resolution / Declaration	Share payable in cash	For a consideration other than cash	Share Capital / Allottees Particulars	List of Shareholders after the Allotment	Summary of Capital
--------------------------	-----------------------	-------------------------------------	---------------------------------------	--	--------------------

**Authorised Capital**

	Amount	Nominal Value per Share	Currency
Authorised Capital :	<b>200000000</b>	<b>.1</b>	<b>SINGAPORE DOLLAR ( 099 )</b>

Description of discrepancy :

**Return of Allotment of Shares (Payable in cash) \***

Applicable only if share is payable in cash

Class of Shares :	Ordinary	Preference	Others
Number of shares :	11600		
Amount paid or due and payable on each share			
paid :	0.10		
due and payable :	0		
Amount of premium paid or payable on each share :	1.50		

[Save](#) | [Delete Issued Share](#) | [Reset](#) | [Back](#)



**Return of Allotment of Shares****Submit**

Please fill in the following information. Fields marked \* must be completed.

Resolution / Declaration	Share payable in cash	For a consideration other than cash	Share Capital / Allottees Particulars	List of Shareholders after the allotment	Summary of Capital
--------------------------	-----------------------	-------------------------------------	---------------------------------------	--	--------------------

**Particulars of Allottee**

Please indicate whether the allottee is an Individual : \*

- Allottee is an Individual  
 Allottee is NOT an Individual

If Allottee is an Individual :

Shareholder Category : \* **Individual**

Identification No. : \*

**Retrieve Details**

Identification Type : \*

NRIC 

Name : \*

Nationality : \*

Mobile No. :

Occupation :

Email Address :

Address Type : \*

- Local  
 Foreign

Local Address (\* if Address Type is Local Address)

Postal Code :

**Retrieve Address**

Block/House No. :

Street Name :

Unit : #

 - 

Building/Estate Name :

Foreign Address (\* if Address Type is Foreign Address)

Address :

If Allottee is NOT an Individual :

Shareholder Category : \*

Company / Foreign Branch **Search**

Registration No. : \*

198003912M

Retrieve Details

Name : **THE CENTRAL DEPOSITORY (PTE) LIMITED**

Address Type : **Local**

Local Address (\* if Address Type is Local Address)

Postal Code : **068804**

Block/House No. : **2**

Street Name : **SHENTON WAY**

Unit : # **19 - 00**

Building/Estate Name : **SGX CENTRE I**

Foreign Address (\* if Address Type is Foreign Address)

Address :

**Details of Shares Allotted** \* Please read instructions carefully before entering.

Note : If any share or shares is/are co-owned by 2 or more persons, please assign an alphabet e.g. A to denote the Group and enter the same in the box. Enter the same alphabet in the box for every allottee in the same group. Skip this box if share(s) are owned by only one person.

Group of Share that is co-owned:  
(Share Group)

If share(s) is/are co-owned, only one allottee is to enter details in (a), (b), (c), (d) and (e). Enter "0" (zero) for subsequent allottees in box (b) and leave blank for rest of the items.

a) Nominal Value per Share :

0.10

b) No. of shares allotted :

11600

c) Class of shares allotted :

Ordinary

d) Currency :

SINGAPORE DOLLAR (099)

e) Date of allotment :

29/10/2004 (dd/mm/yyyy)

Save

Reset

Back

**Return of Allotment of Shares****Submit**

Please fill in the following information. Fields marked \* must be completed.

<b>Resolution / Declaration</b>	<b>Share payable in cash</b>	<b>For a consideration other than cash</b>	<b>Share Capital / Allottees Particulars</b>	<b>List of Shareholders after Allotment</b>	<b>Summary of Capital</b>
-------------------------------------	----------------------------------	--	--	---	-------------------------------

**List of Allottees and their particulars****Identification****No./Registration Name  
No.****Shareholder Category**

198003912M	THE CENTRAL DEPOSITORY (PTE) LIMITED	Company / Foreign Branch
------------	---	--------------------------

If No. of shareholders exceeds 50, total No. of issued shares held by the remaining shareholders are :

	<b>Ordinary</b>	<b>Preference</b>	<b>Others</b>
<b>No. of Shares</b>	<b>0</b>	<b>0</b>	<b>0</b>

**Return of Allotment of Shares****Submit**

Please fill in the following information. Fields marked \* must be completed.

Resolution / Declaration	Share payable in cash	For a consideration other than cash	Share Capital / Allottees Particulars	List of Shareholders after the allotment	Summary of Capital
<b>Share Capital (1)</b>					
Currency :	<b>SINGAPORE DOLLAR (099)</b>				
Nominal Value per Share :	<b>0.10</b>				
Amount of Authorised Share Capital :	<b>200000000.00</b>				
Class of Shares :	Ordinary	Preference	Others		
Amount of Issued Share Capital :	<b>102578747.50</b>	<b>0.00</b>	<b>0.00</b>		
Amount of Paid-up Share Capital :	<b>102578747.50</b>	<b>0.00</b>	<b>0.00</b>		

GST No. :M9-0008879-T

**RECEIPT**

Receipt No : ACR000000920721A

Date/Time : 01/11/2004 09:05

Transaction  
No : C040497829

Agency : RCB - RCB

Application : BIZFILE PAYMENT SERVICE

Paid via : Deposit Service Account

EP Ref No :

**SINGAPORE AIRPORT TERMINAL SERVICES LIMITED  
20 AIRPORT BOULEVARD  
SATS INFLIGHT CATERING CENTRE 3  
SINGAPORE 819659**

---

<b>Sno Code/Description</b>	<b>Unit Price (S\$)</b>	<b>Qty</b>	<b>Amount</b>
1 Lodgment Of Return Of Allotment Of Share	10.00	1	10.00
<b>COMPANY/BUSINESS NAME :</b> 197201770G / SINGAPORE AIRPORT TERMINAL SERVICES LIMITED			
<b>Total (S\$) :</b>			10.00

---

**Deposit Service Account No. : 030066  
Balance Amount in Deposit Account : \$ 515.00**

This is a computer-generated receipt. No signature is required.

Please print a copy of the receipt for your reference.

HOME
------

LOGOUT
--------

**Return of Allotment of Shares****Submit**

Please fill in the following information. Fields marked \* must be completed.

Resolution/Declaration	Shares payable in cash	For a consideration other than cash	Share Capital/Allottees Particulars	List of Shareholders after the allotment	Summary of Capital
------------------------	---------------------------	---	---	---	-----------------------

**Record saved successfully.****Company Type**

Please click on appropriate button :

- company is listed on the securities exchange  
 company is an unlisted public company  
 company is a private company

**Power under Section 161 of the Companies Act \***

The directors have obtained  
the approval of the company in  Yes  
general meeting to issue  No  
shares.

**Resolution Made**

\* You are only required to fill in this section if the directors are not given the power under Section 161 of the Companies Act to issue shares.

Registration No. : **197201770G**Company Name : **SINGAPORE AIRPORT TERMINAL SERVICES LIMITED**Nature of Meeting : \* 

Place of Meeting : \*

Date of Meeting : \*  (dd/mm/yyyy)Resolution Type : \* Description : \*  
(max 2000 characters)Attachment : \*  
(copy of resolution)**Note :**

Uploaded file name will be  
changed by suffixing time-  
stamp with the actual file  
name as

filenameyyyyMMddmmsstt

**Browse...**

(Click 'Browse' to select file for attachment)

**Persons signing the resolution**

Please indicate the directors/ secretaries who signed the resolution :

- S0036442H / OW CHIN HOCK
- S0070715E / NG KEE CHOE
- S0234645A / CHEW CHOON SENG
- S1001765C / BARRY HENRY PATRICK DESKER
- S1069567H / TAN JIAK NGEE MICHAEL
- S1673157I / YIP WAI PING ANNABELLE
- S1852301I / HONG HAI @ HUANG HAI
- S2163476Z / CHENG WAI WING EDMUND
- S2580327B / RICHARD CHARLES HELFER

Please enter names of other corporate representatives who signed the resolution, if applicable :

**Declaration**

I, LIM HONG ENG SUSANNA, Professional body/service bureau, declare the information which has been submitted herein to be true to the best of my knowledge.

**Return of Allotment of Shares****Submit**

Please fill in the following information. Fields marked \* must be completed.

Resolution / Declaration	Share payable in cash	For a consideration other than cash	Share Capital / Allottees Particulars	List of Shareholders after the Allotment	Summary of Capital
<b>Authorised Capital</b>					
	Amount		Nominal Value per Share	Currency	
Authorised Capital :	<b>200000000</b>		<b>.1</b>	<b>SINGAPORE DOLLAR ( 099 )</b>	

Description of discrepancy :

**Return of Allotment of Shares (Payable in cash) \***

Applicable only if share is payable in cash

Class of Shares :	Ordinary	Preference	Others
Number of shares :	2600		
Amount paid or due and payable on each share			
paid :	0.10		
due and payable :	0		
Amount of premium paid or payable on each share :	1.14		

**Save****Delete Issued Share****Reset****Back**



**Return of Allotment of Shares****Submit**

Please fill in the following information. Fields marked \* must be completed.

Resolution / Declaration	Share payable in cash	For a consideration other than cash	Share Capital / Allottees Particulars	List of Shareholders after the allotment	Summary of Capital
--------------------------	-----------------------	-------------------------------------	---------------------------------------	--	--------------------

**Particulars of Allottee**

Please indicate whether the allottee is an Individual : \*

- Allottee is an Individual  
 Allottee is NOT an Individual

**If Allottee is an Individual :**Shareholder Category : \* **Individual**Identification No. : \*  **Retrieve Details**Identification Type : \* Name : \* Nationality : \* Mobile No. : Occupation : Email Address : Address Type : \*  
 Local  
 Foreign

Local Address (\* if Address Type is Local Address)

Postal Code :  **Retrieve Address**Block/House No. : Street Name : Unit : #  - Building/Estate Name : 

Foreign Address (\* if Address Type is Foreign Address)

Address : **If Allottee is NOT an Individual :**Shareholder Category : \*  **Search**

Name : **THE CENTRAL DEPOSITORY (PTE) LIMITED**Address Type : **Local**

Local Address (\* if Address Type is Local Address)

Postal Code : **068804**Block/House No. : **2**Street Name : **SHENTON WAY**Unit : # **19 - 00**Building/Estate Name : **SGX CENTRE I**

Foreign Address (\* if Address Type is Foreign Address)

Address :

**Details of Shares Allotted** \* Please read instructions carefully before entering.

Note : If any share or shares is/are co-owned by 2 or more persons, please assign an alphabet e.g. A to denote the Group and enter the same in the box. Enter the same alphabet in the box for every allottee in the same group. Skip this box if share(s) are owned by only one person.

Group of Share that is co-owned:  
(Share Group)

If share(s) is/are co-owned, only one allottee is to enter details in (a), (b), (c), (d) and (e). Enter "0" (zero) for subsequent allottees in box (b) and leave blank for rest of the items.

a) Nominal Value per Share :

b) No. of shares allotted :

c) Class of shares allotted :

d) Currency :

e) Date of allotment :

 (dd/mm/yyyy)

**Return of Allotment of Shares****Submit**

Please fill in the following information. Fields marked \* must be completed.

<b>Resolution / Declaration</b>	<b>Share payable in cash</b>	<b>For a consideration other than cash</b>	<b>Share Capital / Allottees Particulars</b>	<b>List of Shareholders after Allotment</b>	<b>Summary of Capital</b>
-------------------------------------	----------------------------------	--	--	---	-------------------------------

**List of Allottees and their particulars****Identification****No./Registration Name  
No.****Shareholder Category**

198003912M	THE CENTRAL DEPOSITORY (PTE) LIMITED	Company / Foreign Branch
------------	---	--------------------------

If No. of shareholders exceeds 50, total No. of issued shares held by the remaining shareholders are :

<b>No. of Shares</b>	<b>Ordinary</b>	<b>Preference</b>	<b>Others</b>
	0	0	0

**Return of Allotment of Shares****Submit**

Please fill in the following information. Fields marked \* must be completed.

Resolution / Declaration	Share payable in cash	For a consideration other than cash	Share Capital / Allottees Particulars	List of Shareholders after the allotment	Summary of Capital
--------------------------	-----------------------	-------------------------------------	---------------------------------------	--	--------------------

**Share Capital (1)**

Currency :	<b>SINGAPORE DOLLAR (099)</b>		
Nominal Value per Share :	<b>0.10</b>		
Amount of Authorised Share Capital :	<b>200000000.00</b>		
Class of Shares :	Ordinary	Preference	Others
Amount of Issued Share Capital :	<b>102577587.50</b>	<b>0.00</b>	<b>0.00</b>
Amount of Paid-up Share Capital :	<b>102577587.50</b>	<b>0.00</b>	<b>0.00</b>

GST No. :M9-0008879-T

**RECEIPT**

Receipt No : ACR0000000920717A

Date/Time : 01/11/2004 09:00

Transaction No : C040497826

Agency : RCB - RCB

Application : BIZFILE PAYMENT SERVICE

Paid via : Deposit Service Account

EP Ref No :

**SINGAPORE AIRPORT TERMINAL SERVICES LIMITED****20 AIRPORT BOULEVARD****SATS INFLIGHT CATERING CENTRE 3****SINGAPORE 819659**

---

<b>Sno Code/Description</b>	<b>Unit Price (S\$)</b>	<b>Qty</b>	<b>Amount</b>
1 Lodgment Of Return Of Allotment Of Share <b>COMPANY/BUSINESS NAME :</b> 197201770G / SINGAPORE AIRPORT TERMINAL SERVICES LIMITED	10.00	1	10.00
<b>Total (S\$) :</b>			<b>10.00</b>

---

**Deposit Service Account No. : 030066**  
**Balance Amount in Deposit Account : \$ 525.00**

This is a computer-generated receipt. No signature is required.

Please print a copy of the receipt for your reference.

[HOME](#)[LOGOUT](#)

**Return of Allotment of Shares****Submit**

Please fill in the following information. Fields marked \* must be completed.

Resolution/Declaration	Shares payable in cash	For a consideration other than cash	Share Capital/Allottees Particulars	List of Shareholders after the allotment	Summary of Capital
------------------------	---------------------------	---	---	---	-----------------------

**Record saved successfully.****Company Type**

Please click on appropriate button :

- company is listed on the securities exchange  
 company is an unlisted public company  
 company is a private company

**Power under Section 161 of the Companies Act \***

The directors have obtained  
the approval of the company in  
general meeting to issue  
shares.

Yes  
 No

**Resolution Made**

\* You are only required to fill in this section if the directors are not given the power under Section 161 of the Companies Act to issue shares.

Registration No. : **197201770G**Company Name : **SINGAPORE AIRPORT TERMINAL SERVICES LIMITED**Nature of Meeting : \* **Directors**

Place of Meeting : \*

Date of Meeting : \* (dd/mm/yyyy)

Resolution Type : \* **Director's**Description : \*  
(max 2000 characters)Attachment : \*  
(copy of resolution)**Note :**

Uploaded file name will be  
changed by suffixing time-  
stamp with the actual file  
name as

**filenameyyyyMMddmmsstt****Browse...**

(Click 'Browse' to select file for attachment)

**Persons signing the resolution**

Please indicate the directors/ secretaries who signed the resolution :

- S0036442H / OW CHIN HOCK
- S0070715E / NG KEE CHOE
- S0234645A / CHEW CHOON SENG
- S1001765C / BARRY HENRY PATRICK DESKER
- S1069567H / TAN JIAK NGEE MICHAEL
- S1673157I / YIP WAI PING ANNABELLE
- S1852301I / HONG HAI @ HUANG HAI
- S2163476Z / CHENG WAI WING EDMUND
- S2580327B / RICHARD CHARLES HELFER

Please enter names of other corporate representatives who signed the resolution, if applicable :

**Declaration**

I, LIM HONG ENG SUSANNA, Professional body/service bureau, declare the information which has been submitted herein to be true to the best of my knowledge.

**Return of Allotment of Shares**

Submit

Please fill in the following information. Fields marked \* must be completed.

Resolution / Declaration	Share payable in cash	For a consideration other than cash	Share Capital / Allottees Particulars	List of Shareholders after the Allotment	Summary of Capital
--------------------------	-----------------------	-------------------------------------	---------------------------------------	--	--------------------

**Authorised Capital**

	Amount	Nominal Value per Share	Currency
Authorised Capital :	<b>200000000</b>	<b>.1</b>	<b>SINGAPORE DOLLAR ( 099 )</b>

Description of discrepancy :

**Return of Allotment of Shares (Payable in cash) \***

Applicable only if share is payable in cash

Class of Shares :	Ordinary	Preference	Others
Number of shares :	2600 /		
Amount paid or due and payable on each share			
paid :	0.10		
due and payable :	0		
Amount of premium paid or payable on each share :	1.70		

Save

Delete Issued Share

Reset

Back



**Return of Allotment of Shares**

[Submit](#)

Please fill in the following information. Fields marked \* must be completed.

Resolution / Declaration	Share payable in cash	For a consideration other than cash	Share Capital / Allottees Particulars	List of Shareholders after the allotment	Summary of Capital
--------------------------	-----------------------	-------------------------------------	---------------------------------------	--	--------------------

**Particulars of Allottee**

Please indicate whether the allottee is an Individual : \*

- Allottee is an Individual
- Allottee is NOT an Individual

**If Allottee is an Individual :**

Shareholder Category : \* **Individual**

Identification No. : \*  [Retrieve Details](#)

Identification Type : \*

Name : \*

Nationality : \*

Mobile No :

Occupation :

Email Address :

Address Type : \*  Local  Foreign

Local Address (\* if Address Type is Local Address)

Postal Code :  [Retrieve Address](#)

Block/House No. :

Street Name :

Unit : #  -

Building/Estate Name :

Foreign Address (\* if Address Type is Foreign Address)

Address :

**If Allottee is NOT an Individual :**

Shareholder Category : \*  [Search](#)

Name : **THE CENTRAL DEPOSITORY (PTE) LIMITED**Address Type : **Local**

Local Address (\* if Address Type is Local Address)

Postal Code : **068804**Block/House No. : **2**Street Name : **SHENTON WAY**Unit : # **19 - 00**Building/Estate Name : **SGX CENTRE I**

Foreign Address (\* if Address Type is Foreign Address)

Address :

**Details of Shares Allotted** \* Please read instructions carefully before entering.

Note : If any share or shares is/are co-owned by 2 or more persons, please assign an alphabet e.g. A to denote the Group and enter the same in the box. Enter the same alphabet in the box for every allottee in the same group. Skip this box if share(s) are owned by only one person.

Group of Share that is co-owned:  
(Share Group)

If share(s) is/are co-owned, only one allottee is to enter details in (a), (b), (c), (d) and (e). Enter "0" (zero) for subsequent allottees in box (b) and leave blank for rest of the items.

a) Nominal Value per Share :

b) No. of shares allotted :

c) Class of shares allotted :

d) Currency :

e) Date of allotment :

 (dd/mm/yyyy)

**Return of Allotment of Shares****Submit**

Please fill in the following information. Fields marked \* must be completed.

<b>Resolution / Declaration</b>	<b>Share payable in cash</b>	<b>For a consideration other than cash</b>	<b>Share Capital / Allottees Particulars</b>	<b>List of Shareholders after Allotment</b>	<b>Summary of Capital</b>
-------------------------------------	----------------------------------	--	--	---	-------------------------------

**List of Allottees and their particulars****Identification****No./Registration Name  
No.****Shareholder Category**

198003912M	THE CENTRAL DEPOSITORY (PTE) LIMITED	Company / Foreign Branch
------------	---	--------------------------

If No. of shareholders exceeds 50, total No. of issued shares held by the remaining shareholders are :

<b>No. of Shares</b>	<b>Ordinary</b>	<b>Preference</b>	<b>Others</b>
	0	0	0

**Return of Allotment of Shares****Submit**

Please fill in the following information. Fields marked \* must be completed.

Resolution / Declaration	Share payable in cash	For a consideration other than cash	Share Capital / Allottees Particulars	List of Shareholders after the allotment	Summary of Capital
<b>Share Capital (1)</b>					
Currency :	<b>SINGAPORE DOLLAR (099)</b>				
Nominal Value per Share :	<b>0.10</b>				
Amount of Authorised Share Capital :	<b>200000000.00</b>				
Class of Shares :	Ordinary	Preference	Others		
Amount of Issued Share Capital :	<b>102577327.50</b>	<b>0.00</b>	<b>0.00</b>		
Amount of Paid-up Share Capital :	<b>102577327.50</b>	<b>0.00</b>	<b>0.00</b>		

SEC. MAIL REC'D  
JAN 03 2004  
SECTION 202  
WASH., D.C.

**SINGAPORE AIRPORT TERMINAL SERVICES LIMITED**

**Biz-Filing with Registry of Companies and Businesses**

<u>Date of Filing</u>	<u>Form</u>
28 Oct 2004	Lodgment of Return of Allotment of Share – 3,900 shares
28 Oct 2004	Lodgment of Return of Allotment of Share – 24,700 shares
28 Oct 2004	Lodgment of Return of Allotment of Share – 33,800 shares
28 Oct 2004	Lodgment of Return of Allotment of Share – 2,600 shares
28 Oct 2004	Lodgment of Return of Allotment of Share – 2,600 shares
28 Oct 2004	Lodgment of Return of Allotment of Share – 5,200 shares
26 Oct 2004	Lodgment of Return of Allotment of Share – 7,700 shares
26 Oct 2004	Lodgment of Return of Allotment of Share – 5,200 shares
26 Oct 2004	Lodgment of Return of Allotment of Share – 5,200 shares
25 Oct 2004	Lodgment of Return of Allotment of Share – 18,800 shares
25 Oct 2004	Lodgment of Return of Allotment of Share – 10,400 shares
22 Oct 2004	Lodgment of Return of Allotment of Share – 13,000 shares
22 Oct 2004	Lodgment of Return of Allotment of Share – 7,800 shares
22 Oct 2004	Lodgment of Return of Allotment of Share – 7,800 shares
22 Oct 2004	Lodgment of Return of Allotment of Share – 10,400 shares
22 Oct 2004	Lodgment of Return of Allotment of Share – 5,200 shares
22 Oct 2004	Lodgment of Return of Allotment of Share – 5,200 shares
21 Oct 2004	Lodgment of Return of Allotment of Share – 67,600 shares
21 Oct 2004	Lodgment of Return of Allotment of Share – 32,500 shares

21 Oct 2004	Lodgment of Return of Allotment of Share – 44,200 shares
19 Oct 2004	Lodgment of Return of Allotment of Share – 72,800 shares
19 Oct 2004	Lodgment of Return of Allotment of Share – 20,800 shares
19 Oct 2004	Lodgment of Return of Allotment of Share – 50,700 shares
18 Oct 2004	Lodgment of Return of Allotment of Share – 83,800 shares
18 Oct 2004	Lodgment of Return of Allotment of Share – 35,100 shares
18 Oct 2004	Lodgment of Return of Allotment of Share – 65,600 shares
18 Oct 2004	Lodgment of Return of Allotment of Share – 129,300 shares
18 Oct 2004	Lodgment of Return of Allotment of Share – 32,500 shares
18 Oct 2004	Lodgment of Return of Allotment of Share – 70,800 shares
14 Oct 2004	Lodgment of Return of Allotment of Share – 98,400 shares
14 Oct 2004	Lodgment of Return of Allotment of Share – 28,200 shares
14 Oct 2004	Lodgment of Return of Allotment of Share – 7,800 shares
13 Oct 2004	Lodgment of Return of Allotment of Share – 105,200 shares
13 Oct 2004	Lodgment of Return of Allotment of Share – 41,600 shares
13 Oct 2004	Lodgment of Return of Allotment of Share – 120,200 shares
12 Oct 2004	Lodgment of Return of Allotment of Share – 13,000 shares
12 Oct 2004	Lodgment of Return of Allotment of Share – 6,000 shares
12 Oct 2004	Lodgment of Return of Allotment of Share – 15,600 shares
11 Oct 2004	Lodgment of Return of Allotment of Share – 70,100 shares
11 Oct 2004	Lodgment of Return of Allotment of Share – 7,800 shares
11 Oct 2004	Lodgment of Return of Allotment of Share – 16,200 shares
08 Oct 2004	Lodgment of Return of Allotment of Share – 96,200 shares
08 Oct 2004	Lodgment of Return of Allotment of Share – 41,600 shares
08 Oct 2004	Lodgment of Return of Allotment of Share – 96,200 shares

07 Oct 2004	Lodgment of Return of Allotment of Share – 92,800 shares
07 Oct 2004	Lodgment of Return of Allotment of Share – 50,000 shares
07 Oct 2004	Lodgment of Return of Allotment of Share – 78,600 shares
05 Oct 2004	Lodgment of Return of Allotment of Share – 98,800 shares
05 Oct 2004	Lodgment of Return of Allotment of Share – 15,600 shares
05 Oct 2004	Lodgment of Return of Allotment of Share – 28,600 shares
04 Oct 2004	Lodgment of Return of Allotment of Share – 94,200 shares
04 Oct 2004	Lodgment of Return of Allotment of Share – 10,400 shares
04 Oct 2004	Lodgment of Return of Allotment of Share – 49,400 shares
04 Oct 2004	Lodgment of Notice of Appointment/Cessation of Appointment

**INFORMATION RESOURCES****Receipt Enquiry**

This is a comprehensive listing of receipts available for all transactions.

Receipt No. : ACR0000000914042A  
Date and Time : 28/10/2004 10:40:15  
Payment Mode : DEPOSIT SERVICE ACCOUNT  
Deposit Service Account No : 030066  
Status of Receipt : Processed

**Payment Details**

<b>S/No</b>	<b>Payment Description</b>	<b>Transaction No.</b>	<b>Amount</b>	<b>GST</b>
1	Lodgment Of Return Of Allotment Of Share/Regn No:197201770G/	C040489950	10.00	0.00
<b>Total</b>			<b>10.00</b>	<b>0.00</b>

[Back](#)



**Return of Allotment of Shares**

Submit

Please fill in the following information. Fields marked \* must be completed.

Resolution/Declaration	Shares payable in cash	For a consideration other than cash	Share Capital/Allottees Particulars	List of Shareholders after the allotment	Summary of Capital
------------------------	---------------------------	---	---	---	-----------------------

**Record saved successfully.****Company Type**

Please click on appropriate button :

- company is listed on the securities exchange  
 company is an unlisted public company  
 company is a private company

**Power under Section 161 of the Companies Act \***

The directors have obtained the approval of the company in  Yes  No general meeting to issue shares.

**Resolution Made**

\* You are only required to fill in this section if the directors are not given the power under Section 161 of the Companies Act to issue shares.

Registration No. : **197201770G**Company Name : **SINGAPORE AIRPORT TERMINAL SERVICES LIMITED**

Nature of Meeting : \* Directors

Place of Meeting : \*

Date of Meeting : \* (dd/mm/yyyy)

Resolution Type : \* Director's

Description : \*  
(max 2000 characters)Attachment : \*  
(copy of resolution)**Note :**

Uploaded file name will be changed by suffixing time-stamp with the actual file name as

filenameyyyyMMddmmsstt

Browse...

(Click 'Browse' to select file for attachment)

**Persons signing the resolution**

Please indicate the directors/ secretaries who signed the resolution :

- S0036442H / OW CHIN HOCK
- S0070715E / NG KEE CHOE
- S0234645A / CHEW CHOON SENG
- S1001765C / BARRY HENRY PATRICK DESKER
- S1069567H / TAN JIAK NGEE MICHAEL
- S1673157I / YIP WAI PING ANNABELLE
- S1852301I / HONG HAI @ HUANG HAI
- S2163476Z / CHENG WAI WING EDMUND
- S2580327B / RICHARD CHARLES HELFER

Please enter names of other corporate representatives who signed the resolution, if applicable :

**Declaration**

I, LIM HONG ENG SUSANNA, Professional body/service bureau, declare the information which has been submitted herein to be true to the best of my knowledge.

**Return of Allotment of Shares****Submit**

Please fill in the following information. Fields marked \* must be completed.

<b>Resolution / Declaration</b>	<b>Share payable in cash</b>	<b>For a consideration other than cash</b>	<b>Share Capital / Allottees Particulars</b>	<b>List of Shareholders after the Allotment</b>	<b>Summary of Capital</b>
-------------------------------------	----------------------------------	--	--	---	-------------------------------

**Authorised Capital**

	<b>Amount</b>	<b>Nominal Value per Share</b>	<b>Currency</b>
Authorised Capital :	<b>200000000</b>	<b>.1</b>	<b>SINGAPORE DOLLAR ( 099 )</b>

Description of discrepancy :

**Return of Allotment of Shares (Payable in cash) \***

Applicable only if share is payable in cash

<b>Class of Shares :</b>	<b>Ordinary</b>	<b>Preference</b>	<b>Others</b>
Number of shares :	<input type="text" value="3900"/>	<input type="text"/>	<input type="text"/>
Amount paid or due and payable on each share			
paid :	<input type="text" value="0.10"/>	<input type="text"/>	<input type="text"/>
due and payable :	<input type="text" value="0"/>	<input type="text"/>	<input type="text"/>
Amount of premium paid or payable on each share :	<input type="text" value="1.37"/>	<input type="text"/>	<input type="text"/>

**Save****Delete Issued Share****Reset****Back**

**Return of Allotment of Shares**

Submit

Please fill in the following information. Fields marked \* must be completed.

Resolution / Declaration	Share payable in cash	For a consideration other than cash	Share Capital / Allottees Particulars	List of Shareholders after the allotment	Summary of Capital
--------------------------	-----------------------	-------------------------------------	---------------------------------------	--	--------------------

**Particulars of Allottee**

Please indicate whether the allottee is an Individual : \*

- Allottee is an Individual
- Allottee is NOT an Individual

If Allottee is an Individual :

Shareholder Category : \* **Individual**Identification No. : \*  Retrieve DetailsIdentification Type : \* Name : \* Nationality : \* Mobile No : Occupation : Email Address : Address Type : \*  Local  
 Foreign

Local Address (\* if Address Type is Local Address)

Postal Code :  Retrieve AddressBlock/House No. : 

Street Name :

Unit : #  - 

Building/Estate Name :

Foreign Address (\* if Address Type is Foreign Address)

Address :   

If Allottee is NOT an Individual :

Shareholder Category : \*  Search

Registration No. : **15000972M** **Retrieve Details**  
Name : **THE CENTRAL DEPOSITORY (PTE) LIMITED**

Address Type : **Local**

Local Address (\* if Address Type is Local Address)

Postal Code : **068804**

Block/House No. : **2**

Street Name : **SHENTON WAY**

Unit : # **19 - 00**

Building/Estate Name : **SGX CENTRE I**

Foreign Address (\* if Address Type is Foreign Address)

Address :

**Details of Shares Allotted** \* Please read instructions carefully before entering.

Note : If any share or shares is/are co-owned by 2 or more persons, please assign an alphabet e.g. A to denote the Group and enter the same in the box. Enter the same alphabet in the box for every allottee in the same group. Skip this box if share(s) are owned by only one person.

Group of Share that is co-owned:  
(Share Group)

If share(s) is/are co-owned, only one allottee is to enter details in (a), (b), (c), (d) and (e). Enter "0" (zero) for subsequent allottees in box (b) and leave blank for rest of the items.

- a) Nominal Value per Share :
- b) No. of shares allotted :
- c) Class of shares allotted :
- d) Currency :
- e) Date of allotment :  (dd/mm/yyyy)

**Return of Allotment of Shares**[Submit](#)

Please fill in the following information. Fields marked \* must be completed.

Resolution / Declaration	Share payable in cash	For a consideration other than cash	Share Capital / Allottees Particulars	List of Shareholders after Allotment	Summary of Capital
--------------------------	-----------------------	-------------------------------------	---------------------------------------	--------------------------------------	--------------------

**List of Allottees and their particulars****Identification****No./Registration Name No.****Shareholder Category**

198003912M	THE CENTRAL DEPOSITORY (PTE) LIMITED	Company / Foreign Branch
------------	--------------------------------------	--------------------------

If No. of shareholders exceeds 50, total No. of issued shares held by the remaining shareholders are :

No. of Shares	Ordinary	Preference	Others
	0	0	0

**Return of Allotment of Shares****Submit**

Please fill in the following information. Fields marked \* must be completed.

<u>Resolution / Declaration</u>	<u>Share payable in cash</u>	<u>For a consideration other than cash</u>	<u>Share Capital / Allottees Particulars</u>	<u>List of Shareholders after the allotment</u>	<u>Summary of Capital</u>
-------------------------------------	----------------------------------	--	--	---	-------------------------------

**Share Capital (1)**

Currency :	<b>SINGAPORE DOLLAR (099)</b>		
Nominal Value per Share :	<b>0.10</b>		
Amount of Authorised Share Capital :	<b>200000000.00</b>		
Class of Shares :	Ordinary	Preference	Others
Amount of Issued Share Capital :	<b>102577067.50</b>	<b>0.00</b>	<b>0.00</b>
Amount of Paid-up Share Capital :	<b>102577067.50</b>	<b>0.00</b>	<b>0.00</b>

**RECEIPT**

Receipt No : ACR0000000913882A

Date/Time : 28/10/2004 10:06

Transaction  
No : C040489780

Agency : RCB - RCB

Application : BIZFILE PAYMENT SERVICE

Paid via : Deposit Service Account

EP Ref No :

**SINGAPORE AIRPORT TERMINAL SERVICES LIMITED**  
**20 AIRPORT BOULEVARD**  
**SATS INFLIGHT CATERING CENTRE 3**  
**SINGAPORE 819659**

<b>Sno Code/Description</b>	<b>Unit Price (S\$)</b>	<b>Qty</b>	<b>Amount</b>
1 Lodgment Of Return Of Allotment Of Share <b>COMPANY/BUSINESS NAME :</b> 197201770G / SINGAPORE AIRPORT TERMINAL SERVICES LIMITED	10.00	1	10.00
<b>Total (S\$) :</b>			<b>10.00</b>

**Deposit Service Account No. : 030066****Balance Amount in Deposit Account : \$ 45.00****Your deposit account has reached minimum balance of \$50. Please top-up.**

This is a computer-generated receipt. No signature is required.

Please print a copy of the receipt for your reference.

[HOME](#)[LOGOUT](#)



**LOCAL COMPANY TRANSACTIONS**[HOME](#) [LOGOUT](#)**Return of Allotment of Shares**[Submit](#)

Please fill in the following information. Fields marked \* must be completed.

Resolution/Declaration	Shares payable in cash	For a consideration other than cash	Share Capital/Allottees Particulars	List of Shareholders after the allotment	Summary of Capital
------------------------	---------------------------	---	---	---	-----------------------

**Record saved successfully.****Company Type**

Please click on appropriate button :

- company is listed on the securities exchange  
 company is an unlisted public company  
 company is a private company

**Power under Section 161 of the Companies Act \***

The directors have obtained  
the approval of the company in  Yes  
general meeting to issue  No  
shares.

**Resolution Made**

\* You are only required to fill in this section if the directors are not given the power under Section 161 of the Companies Act to issue shares.

Registration No. : **197201770G**Company Name : **SINGAPORE AIRPORT TERMINAL SERVICES LIMITED**Nature of Meeting : \* Place of Meeting : \*   
Date of Meeting : \*  (dd/mm/yyyy)Resolution Type : \* Description : \*  
(max 2000 characters) Attachment : \*  
(copy of resolution)**Note :**

Uploaded file name will be  
changed by suffixing time-  
stamp with the actual file  
name as

**filenameyyyyMMddmmsstt** [Browse...](#)

(Click 'Browse' to select file for attachment)

**Persons signing the resolution**

Please indicate the directors/ secretaries who signed the resolution :

- S0036442H / OW CHIN HOCK
- S0070715E / NG KEE CHOE
- S0234645A / CHEW CHOON SENG
- S1001765C / BARRY HENRY PATRICK DESKER
- S1069567H / TAN JIAK NGEE MICHAEL
- S1673157I / YIP WAI PING ANNABELLE
- S1852301I / HONG HAI @ HUANG HAI
- S2163476Z / CHENG WAI WING EDMUND
- S2580327B / RICHARD CHARLES HELFER

Please enter names of other corporate representatives who signed the resolution, if applicable :

**Declaration**

I, LIM HONG ENG SUSANNA, Professional body/service bureau, declare the information which has been submitted herein to be true to the best of my knowledge.

**Return of Allotment of Shares****Submit**

Please fill in the following information. Fields marked \* must be completed.

<u>Resolution / Declaration</u>	Share payable in cash	For a consideration other than cash	Share Capital / Allottees Particulars	List of Shareholders after the Allotment	Summary of Capital
---------------------------------	-----------------------	-------------------------------------	---------------------------------------	--	--------------------

**Authorised Capital**

	Amount	Nominal Value per Share	Currency
Authorised Capital :	<b>200000000</b>	<b>.1</b>	<b>SINGAPORE DOLLAR ( 099 )</b>

Description of discrepancy :

**Return of Allotment of Shares (Payable in cash) \***

Applicable only if share is payable in cash

Class of Shares :	Ordinary	Preference	Others
Number of shares :	24700		
Amount paid or due and payable on each share			
paid :	0.10		
due and payable :	0		
Amount of premium paid or payable on each share :	1.50		

**Save****Delete Issued Share****Reset****Back**

**Return of Allotment of Shares****Submit**

Please fill in the following information. Fields marked \* must be completed.

Resolution / Declaration	Share payable in cash	For a consideration other than cash	Share Capital / Allottees Particulars	List of Shareholders after the allotment	Summary of Capital
--------------------------	-----------------------	-------------------------------------	---------------------------------------	--	--------------------

**Particulars of Allottee****Please indicate whether the allottee is an Individual : \***

- Allottee is an Individual
- Allottee is NOT an Individual

**If Allottee is an Individual :**Shareholder Category : \* **Individual**Identification No. : \*  **Retrieve Details**Identification Type : \*  ▼Name : \* Nationality : \*  ▼Mobile No : Occupation : Email Address : Address Type : \*  Local  Foreign

Local Address (\* if Address Type is Local Address)

Postal Code :  **Retrieve Address**Block/House No. : 

Street Name :

Unit : #  - 

Building/Estate Name :

Foreign Address (\* if Address Type is Foreign Address)

Address :   
**If Allottee is NOT an Individual :**Shareholder Category : \*  ▼ **Search**

Registration No. : \*

198003912M

Retrieve Details

Name :

**THE CENTRAL DEPOSITORY (PTE) LIMITED**

Address Type :

**Local**

Local Address (\* if Address Type is Local Address)

Postal Code : **068804**

Block/House No. : **2**

Street Name : **SHENTON WAY**

Unit : # **19 - 00**

Building/Estate Name : **SGX CENTRE I**

Foreign Address (\* if Address Type is Foreign Address)

Address :

**Details of Shares Allotted** \* Please read instructions carefully before entering.

Note : If any share or shares is/are co-owned by 2 or more persons, please assign an alphabet e.g. A to denote the Group and enter the same in the box. Enter the same alphabet in the box for every allottee in the same group. Skip this box if share(s) are owned by only one person.

Group of Share that is co-owned:  
(Share Group)

If share(s) is/are co-owned, only one allottee is to enter details in (a), (b), (c), (d) and (e). Enter "0" (zero) for subsequent allottees in box (b) and leave blank for rest of the items.

a) Nominal Value per Share :

0.10

b) No. of shares allotted :

24700

c) Class of shares allotted :

Ordinary

d) Currency :

SINGAPORE DOLLAR (099)

e) Date of allotment :

25/10/2004 (dd/mm/yyyy)

Save Reset Back

**Return of Allotment of Shares****Submit**

Please fill in the following information. Fields marked \* must be completed.

<b>Resolution / Declaration</b>	<b>Share payable in cash</b>	<b>For a consideration other than cash</b>	<b>Share Capital / Allottees Particulars</b>	<b>List of Shareholders after Allotment</b>	<b>Summary of Capital</b>
-------------------------------------	----------------------------------	--	--	---	-------------------------------

**List of Allottees and their particulars****Identification****No./Registration Name  
No.****Shareholder Category**

198003912M	THE CENTRAL DEPOSITORY (PTE) LIMITED	Company / Foreign Branch
------------	---	--------------------------

If No. of shareholders exceeds 50, total No. of issued shares held by the remaining shareholders are :

<b>No. of Shares</b>	<b>Ordinary</b>	<b>Preference</b>	<b>Others</b>
	0	0	0

**Return of Allotment of Shares****Submit**

Please fill in the following information. Fields marked \* must be completed.

<u>Resolution / Declaration</u>	<u>Share payable in cash</u>	<u>For a consideration other than cash</u>	<u>Share Capital / Allottees Particulars</u>	<u>List of Shareholders after the allotment</u>	<u>Summary of Capital</u>
<b>Share Capital (1)</b>					
Currency :	<b>SINGAPORE DOLLAR (099)</b>				
Nominal Value per Share :	<b>0.10</b>				
Amount of Authorised Share Capital :	<b>200000000.00</b>				
Class of Shares :	Ordinary	Preference	Others		
Amount of Issued Share Capital :	<b>102576677.50</b>	<b>0.00</b>	<b>0.00</b>		
Amount of Paid-up Share Capital :	<b>102576677.50</b>	<b>0.00</b>	<b>0.00</b>		

GST No. :M9-0008879-T

**RECEIPT**

Receipt No : ACR0000000913860A

Date/Time : 28/10/2004 10:01

Transaction No : C040489760

Agency : RCB - RCB

Application : BIZFILE PAYMENT SERVICE

Paid via : Deposit Service Account

EP Ref No :

**SINGAPORE AIRPORT TERMINAL SERVICES LIMITED****20 AIRPORT BOULEVARD****SATS INFLIGHT CATERING CENTRE 3****SINGAPORE 819659**

---

<b>Sno Code/Description</b>	<b>Unit Price (S\$)</b>	<b>Qty</b>	<b>Amount</b>
1 Lodgment Of Return Of Allotment Of Share <b>COMPANY/BUSINESS NAME :</b> 197201770G / SINGAPORE AIRPORT TERMINAL SERVICES LIMITED	10.00	1	10.00
<b>Total (S\$) :</b>			<b>10.00</b>

---

**Deposit Service Account No. : 030066****Balance Amount in Deposit Account : \$ 55.00**

This is a computer-generated receipt. No signature is required.

Please print a copy of the receipt for your reference.

[HOME](#)[LOGOUT](#)



**LOCAL COMPANY TRANSACTIONS**[HOME](#)[LOGOUT](#)**Return of Allotment of Shares**[Submit](#)

Please fill in the following information. Fields marked \* must be completed.

Resolution/Declaration	Shares payable in cash	For a consideration other than cash	Share Capital/Allottees Particulars	List of Shareholders after the allotment	Summary of Capital
------------------------	---------------------------	---	---	---	-----------------------

**Record saved successfully.****Company Type**

Please click on appropriate button :

- company is listed on the securities exchange  
 company is an unlisted public company  
 company is a private company

**Power under Section 161 of the Companies Act \***

The directors have obtained the approval of the company in  Yes  No general meeting to issue shares.

**Resolution Made**

\* You are only required to fill in this section if the directors are not given the power under Section 161 of the Companies Act to issue shares.

Registration No. : **197201770G**Company Name : **SINGAPORE AIRPORT TERMINAL SERVICES LIMITED**Nature of Meeting : \* 

Place of Meeting : \*

Date of Meeting : \*  (dd/mm/yyyy)Resolution Type : \* Description : \*  
(max 2000 characters)
Attachment : \*  
(copy of resolution)**Note :**

Uploaded file name will be changed by suffixing time-stamp with the actual file name as

filenameyyyyMMddmmsstt

 [Browse...](#)

(Click 'Browse' to select file for attachment)

**Persons signing the resolution**

Please indicate the directors/ secretaries who signed the resolution :

- S0036442H / OW CHIN HOCK
- S0070715E / NG KEE CHOE
- S0234645A / CHEW CHOON SENG
- S1001765C / BARRY HENRY PATRICK DESKER
- S1069567H / TAN JIAK NGEЕ MICHAEL
- S1673157I / YIP WAI PING ANNABELLE
- S1852301I / HONG HAI @ HUANG HAI
- S2163476Z / CHENG WAI WING EDMUND
- S2580327B / RICHARD CHARLES HELFER

Please enter names of other corporate representatives who signed the resolution, if applicable :

**Declaration**

I, LIM HONG ENG SUSANNA, Professional body/service bureau, declare the information which has been submitted herein to be true to the best of my knowledge.

**LOCAL COMPANY TRANSACTIONS**[HOME](#) [LOGOUT](#)**Return of Allotment of Shares**[Submit](#)

Please fill in the following information. Fields marked \* must be completed.

<u>Resolution / Declaration</u>	<u>Share payable in cash</u>	<u>For a consideration other than cash</u>	<u>Share Capital / Allottees Particulars</u>	<u>List of Shareholders after the Allotment</u>	<u>Summary of Capital</u>
---------------------------------	------------------------------	--	--	---	---------------------------

**Authorised Capital**

	<u>Amount</u>	<u>Nominal Value per Share</u>	<u>Currency</u>
Authorised Capital :	<b>200000000</b>	<b>.1</b>	<b>SINGAPORE DOLLAR ( 099 )</b>

Description of discrepancy :

**Return of Allotment of Shares (Payable in cash) \***

Applicable only if share is payable in cash

<u>Class of Shares :</u>	<u>Ordinary</u>	<u>Preference</u>	<u>Others</u>
Number of shares :	<input type="text" value="33800"/>	<input type="text"/>	<input type="text"/>
Amount paid or due and payable on each share			
paid :	<input type="text" value="0.10"/>	<input type="text"/>	<input type="text"/>
due and payable :	<input type="text" value="0"/>	<input type="text"/>	<input type="text"/>
Amount of premium paid or payable on each share :	<input type="text" value="1.14"/>	<input type="text"/>	<input type="text"/>

[Save](#) [Delete Issued Share](#) [Reset](#) [Back](#)

**Return of Allotment of Shares**

Submit

Please fill in the following information. Fields marked \* must be completed.

Resolution / Declaration	Share payable in cash	For a consideration other than cash	Share Capital / Allottees Particulars	List of Shareholders after the allotment	Summary of Capital
--------------------------	-----------------------	-------------------------------------	---------------------------------------	--	--------------------

**Particulars of Allottee**

Please indicate whether the allottee is an Individual : \*

- Allottee is an Individual  
 Allottee is NOT an Individual

If Allottee is an Individual :

Shareholder Category : \* **Individual**

Identification No. : \*

Retrieve Details

Identification Type : \*

NRIC 

Name : \*

Nationality : \*

Mobile No :

Occupation :

Email Address :

Address Type : \*

- Local  
 Foreign

Local Address (\* if Address Type is Local Address)

Postal Code :

Retrieve Address

Block/House No. :

Street Name :

Unit : #

 - 

Building/Estate Name :

Foreign Address (\* if Address Type is Foreign Address)

Address :

If Allottee is NOT an Individual :

Shareholder Category : \*

Company / Foreign Branch 

Search

Name : THE CENTRAL DEPOSITORY (PTE) LIMITED

Address Type : Local

Local Address (\* if Address Type is Local Address)

Postal Code : 068804

Block/House No. : 2

Street Name : SHENTON WAY

Unit : # 19 - 00

Building/Estate Name : SGX CENTRE I

Foreign Address (\* if Address Type is Foreign Address)

Address :

**Details of Shares Allotted** \* Please read instructions carefully before entering.

Note : If any share or shares is/are co-owned by 2 or more persons, please assign an alphabet e.g. A to denote the Group and enter the same in the box. Enter the same alphabet in the box for every allottee in the same group. Skip this box if share(s) are owned by only one person.

Group of Share that is co-owned:   
(Share Group)

If share(s) is/are co-owned, only one allottee is to enter details in (a), (b), (c), (d) and (e). Enter "0" (zero) for subsequent allottees in box (b) and leave blank for rest of the items.

a) Nominal Value per Share :

b) No. of shares allotted :

c) Class of shares allotted :

d) Currency :

e) Date of allotment :  (dd/mm/yyyy)

**Return of Allotment of Shares**

Submit

Please fill in the following information. Fields marked \* must be completed.

<b>Resolution / Declaration</b>	<b>Share payable in cash</b>	<b><u>For a consideration other than cash</u></b>	<b>Share Capital / Allottees Particulars</b>	<b>List of Shareholders after Allotment</b>	<b>Summary of Capital</b>
-------------------------------------	----------------------------------	---	--	---	-------------------------------

**List of Allottees and their particulars****Identification****No./Registration Name  
No.****Shareholder Category**

198003912M	THE CENTRAL DEPOSITORY (PTE) LIMITED	Company / Foreign Branch
------------	---	--------------------------

If No. of shareholders exceeds 50, total No. of issued shares held by the remaining shareholders are :

<b>No. of Shares</b>	<b>Ordinary</b>	<b>Preference</b>	<b>Others</b>
	0	0	0

**Return of Allotment of Shares****Submit**

Please fill in the following information. Fields marked \* must be completed.

<u>Resolution / Declaration</u>	<u>Share payable in cash</u>	<u>For a consideration other than cash</u>	<u>Share Capital / Allottees Particulars</u>	<u>List of Shareholders after the allotment</u>	<u>Summary of Capital</u>
-------------------------------------	----------------------------------	--	--	---	-------------------------------

**Share Capital (1)**

Currency :	<b>SINGAPORE DOLLAR (099)</b>		
Nominal Value per Share :	<b>0.10</b>		
Amount of Authorised Share Capital :	<b>200000000.00</b>		
Class of Shares :	Ordinary	Preference	Others
Amount of Issued Share Capital :	<b>102574207.50</b>	<b>0.00</b>	<b>0.00</b>
Amount of Paid-up Share Capital :	<b>102574207.50</b>	<b>0.00</b>	<b>0.00</b>

**RECEIPT**

Receipt No : ACR0000000913825A  
Transaction No : C040489725  
Agency : RCB - RCB  
Application : BIZFILE PAYMENT SERVICE  
Paid via : Deposit Service Account  
EP Ref No :

Date/Time : 28/10/2004 09:55

**SINGAPORE AIRPORT TERMINAL SERVICES LIMITED**  
**20 AIRPORT BOULEVARD**  
**SATS INFLIGHT CATERING CENTRE 3**  
**SINGAPORE 819659**

---

<b>Sno Code/Description</b>	<b>Unit Price (S\$)</b>	<b>Qty</b>	<b>Amount</b>
1 Lodgment Of Return Of Allotment Of Share <b>COMPANY/BUSINESS NAME :</b> 197201770G / SINGAPORE AIRPORT TERMINAL SERVICES LIMITED	10.00	1	10.00
<b>Total (S\$) :</b>			<b>10.00</b>

---

**Deposit Service Account No. : 030066**  
**Balance Amount in Deposit Account : \$ 65.00**

This is a computer-generated receipt. No signature is required.

Please print a copy of the receipt for your reference.

[HOME](#)[LOGOUT](#)



**Return of Allotment of Shares**

Submit

Please fill in the following information. Fields marked \* must be completed.

Resolution/Declaration	Shares payable in cash	For a consideration other than cash	Share Capital/Allottees Particulars	List of Shareholders after the allotment	Summary of Capital
------------------------	---------------------------	---	---	---	-----------------------

**Record saved successfully.****Company Type**

Please click on appropriate button :

- company is listed on the securities exchange  
 company is an unlisted public company  
 company is a private company

**Power under Section 161 of the Companies Act \***

The directors have obtained the approval of the company in  Yes  No general meeting to issue shares.

**Resolution Made**

\* You are only required to fill in this section if the directors are not given the power under Section 161 of the Companies Act to issue shares.

Registration No. : **197201770G**Company Name : **SINGAPORE AIRPORT TERMINAL SERVICES LIMITED**

Nature of Meeting : \* Directors

Place of Meeting : \*

Date of Meeting : \* (dd/mm/yyyy)

Resolution Type : \* Director's

Description : \*  
(max 2000 characters)Attachment : \*  
(copy of resolution)**Note :**

Uploaded file name will be changed by suffixing time-stamp with the actual file name as

filenameyyyyMMddmmsstt

Browse...

(Click 'Browse' to select file for attachment)

### Persons signing the resolution

Please indicate the directors/ secretaries who signed the resolution :

- S0036442H / OW CHIN HOCK
- S0070715E / NG KEE CHOE
- S0234645A / CHEW CHOON SENG
- S1001765C / BARRY HENRY PATRICK DESKER
- S1069567H / TAN JIAK NGEER MICHAEL
- S1673157I / YIP WAI PING ANNABELLE
- S1852301I / HONG HAI @ HUANG HAI
- S2163476Z / CHENG WAI WING EDMUND
- S2580327B / RICHARD CHARLES HELFER

Please enter names of other corporate representatives who signed the resolution, if applicable :

### Declaration

I, LIM HONG ENG SUSANNA, Professional body/service bureau, declare the information which has been submitted herein to be true to the best of my knowledge.

**Return of Allotment of Shares**

[Submit](#)

Please fill in the following information. Fields marked \* must be completed.

<u>Resolution / Declaration</u>	<u>Share payable in cash</u>	<u>For a consideration other than cash</u>	<u>Share Capital / Allottees Particulars</u>	<u>List of Shareholders after the Allotment</u>	<u>Summary of Capital</u>
<b>Authorised Capital</b>					
	Amount		Nominal Value per Share		Currency
Authorised Capital :	<b>20000000</b>		<b>.1</b>		<b>SINGAPORE DOLLAR ( 099 )</b>

Description of discrepancy :

**Return of Allotment of Shares (Payable in cash) \***

Applicable only if share is payable in cash

Class of Shares :	Ordinary	Preference	Others
Number of shares :	<input type="text" value="2600"/>	<input type="text"/>	<input type="text"/>
Amount paid or due and payable on each share			
paid :	<input type="text" value="0.10"/>	<input type="text"/>	<input type="text"/>
due and payable :	<input type="text" value="0"/>	<input type="text"/>	<input type="text"/>
Amount of premium paid or payable on each share :	<input type="text" value="1.70"/>	<input type="text"/>	<input type="text"/>

[Save](#)   [Delete Issued Share](#)   [Reset](#)   [Back](#)

**Return of Allotment of Shares**

Submit

Please fill in the following information. Fields marked \* must be completed.

Resolution / Declaration	Share payable in cash	For a consideration other than cash	Share Capital / Allottees Particulars	List of Shareholders after the allotment	Summary of Capital
--------------------------	-----------------------	-------------------------------------	---------------------------------------	--	--------------------

**Particulars of Allottee**

Please indicate whether the allottee is an Individual : \*

- Allottee is an Individual  
 Allottee is NOT an Individual

If Allottee is an Individual :

Shareholder Category : \* **Individual**Identification No. : \*  Retrieve DetailsIdentification Type : \*  ▼Name : \* Nationality : \*  ▼Mobile No : Occupation : Email Address : 
 Address Type : \*  
 Local  
 Foreign

Local Address (\* if Address Type is Local Address)

Postal Code :  Retrieve AddressBlock/House No. : Street Name : Unit : #  - Building/Estate Name : 

Foreign Address (\* if Address Type is Foreign Address)

Address : 

If Allottee is NOT an Individual :

Shareholder Category : \*  Search

Name : THE CENTRAL DEPOSITORY (PTE) LIMITED

Address Type : Local

Local Address (\* if Address Type is Local Address)

Postal Code : 068804

Block/House No. : 2

Street Name : SHENTON WAY

Unit : # 19 - 00

Building/Estate Name : SGX CENTRE I

Foreign Address (\* if Address Type is Foreign Address)

Address :

**Details of Shares Allotted** \* Please read instructions carefully before entering.

Note : If any share or shares is/are co-owned by 2 or more persons, please assign an alphabet e.g. A to denote the Group and enter the same in the box. Enter the same alphabet in the box for every allottee in the same group. Skip this box if share(s) are owned by only one person.

Group of Share that is co-owned:  
(Share Group) 

If share(s) is/are co-owned, only one allottee is to enter details in (a), (b), (c), (d) and (e). Enter "0" (zero) for subsequent allottees in box (b) and leave blank for rest of the items.

- a) Nominal Value per Share :
- b) No. of shares allotted :
- c) Class of shares allotted :
- d) Currency :
- e) Date of allotment :  (dd/mm/yyyy)

**Return of Allotment of Shares****Submit**

Please fill in the following information. Fields marked \* must be completed.

<b>Resolution / Declaration</b>	<b>Share payable in cash</b>	<b><u>For a consideration other than cash</u></b>	<b>Share Capital / Allottees Particulars</b>	<b>List of Shareholders after Allotment</b>	<b>Summary of Capital</b>
-------------------------------------	----------------------------------	---	--	---	-------------------------------

**List of Allottees and their particulars****Identification****No./Registration Name  
No.****Shareholder Category**

198003912M	THE CENTRAL DEPOSITORY (PTE) LIMITED	Company / Foreign Branch
------------	---	--------------------------

If No. of shareholders exceeds 50, total No. of issued shares held by the remaining shareholders are :

	<b>Ordinary</b>	<b>Preference</b>	<b>Others</b>
<b>No. of Shares</b>	<b>0</b>	<b>0</b>	<b>0</b>

**Return of Allotment of Shares****Submit**

Please fill in the following information. Fields marked \* must be completed.

Resolution / Declaration	Share payable in cash	For a consideration other than cash	Share Capital / Allottees Particulars	List of Shareholders after the allotment	Summary of Capital
--------------------------	-----------------------	-------------------------------------	---------------------------------------	--	--------------------

**Share Capital (1)**

Currency :	<b>SINGAPORE DOLLAR (099)</b>			
Nominal Value per Share :	<b>0.10</b>			
Amount of Authorised Share Capital :	<b>200000000.00</b>			
Class of Shares :	Ordinary	Preference	Others	
Amount of Issued Share Capital :	<b>102570827.50</b>	<b>0.00</b>	<b>0.00</b>	
Amount of Paid-up Share Capital :	<b>102570827.50</b>	<b>0.00</b>	<b>0.00</b>	

**RECEIPT**

Receipt No : ACR0000000913673A

Date/Time : 28/10/2004 08:58

Transaction No : C040489558

Agency : RCB - RCB

Application : BIZFILE PAYMENT SERVICE

Paid via : Deposit Service Account

EP Ref No :

**SINGAPORE AIRPORT TERMINAL SERVICES LIMITED**  
**20 AIRPORT BOULEVARD**  
**SATS INFLIGHT CATERING CENTRE 3**  
**SINGAPORE 819659**

<b>Sno Code/Description</b>	<b>Unit Price (S\$)</b>	<b>Qty</b>	<b>Amount</b>
1 Lodgment Of Return Of Allotment Of Share <b>COMPANY/BUSINESS NAME :</b> 197201770G / SINGAPORE AIRPORT TERMINAL SERVICES LIMITED	10.00	1	10.00
<b>Total (S\$) :</b>			<b>10.00</b>

**Deposit Service Account No. : 030066**  
**Balance Amount in Deposit Account : \$ 75.00**

This is a computer-generated receipt. No signature is required.

Please print a copy of the receipt for your reference.

[HOME](#)[LOGOUT](#)



**Return of Allotment of Shares**

Submit

Please fill in the following information. Fields marked \* must be completed.

Resolution/Declaration	Shares payable in cash	For a consideration other than cash	Share Capital/Allottees Particulars	List of Shareholders after the allotment	Summary of Capital
------------------------	---------------------------	---	---	---	-----------------------

**Record saved successfully.****Company Type**

Please click on appropriate button :

- company is listed on the securities exchange  
 company is an unlisted public company  
 company is a private company

**Power under Section 161 of the Companies Act \***

The directors have obtained the approval of the company in general meeting to issue shares.

Yes  
 No

**Resolution Made**

\* You are only required to fill in this section if the directors are not given the power under Section 161 of the Companies Act to issue shares.

Registration No. : **197201770G**Company Name : **SINGAPORE AIRPORT TERMINAL SERVICES LIMITED**

Nature of Meeting : \* Directors

Place of Meeting : \*

Date of Meeting : \* (dd/mm/yyyy)

Resolution Type : \* Director's

Description : \*  
(max 2000 characters)Attachment : \*  
(copy of resolution)**Note :**

Uploaded file name will be changed by suffixing time-stamp with the actual file name as

filenameyyyyMMddmmsstt

Browse...

(Click 'Browse' to select file for attachment)

**Persons signing the resolution**

Please indicate the directors/ secretaries who signed the resolution :

- S0036442H / OW CHIN HOCK
- S0070715E / NG KEE CHOE
- S0234645A / CHEW CHOON SENG
- S1001765C / BARRY HENRY PATRICK DESKER
- S1069567H / TAN JIAK NGEE MICHAEL
- S1673157I / YIP WAI PING ANNABELLE
- S1852301I / HONG HAI @ HUANG HAI
- S2163476Z / CHENG WAI WING EDMUND
- S2580327B / RICHARD CHARLES HELFER

Please enter names of other corporate representatives who signed the resolution, if applicable :

**Declaration**

I, LIM HONG ENG SUSANNA, Professional body/service bureau, declare the information which has been submitted herein to be true to the best of my knowledge.

**Return of Allotment of Shares**

Submit

Please fill in the following information. Fields marked \* must be completed.

Resolution / Declaration	Share payable in cash	For a consideration other than cash	Share Capital / Allottees Particulars	List of Shareholders after the Allotment	Summary of Capital
--------------------------	-----------------------	-------------------------------------	---------------------------------------	--	--------------------

**Authorised Capital**

	Amount	Nominal Value per Share	Currency
Authorised Capital :	<b>20000000</b>	<b>.1</b>	<b>SINGAPORE DOLLAR ( 099 )</b>

Description of discrepancy :

**Return of Allotment of Shares (Payable in cash) \***

Applicable only if share is payable in cash

Class of Shares :	Ordinary	Preference	Others
Number of shares :	2600		
Amount paid or due and payable on each share			
paid :	0.10		
due and payable :	0		
Amount of premium paid or payable on each share :	1.50		

Save

Delete Issued Share

Reset

Back

**Return of Allotment of Shares****Submit**

Please fill in the following information. Fields marked \* must be completed.

Resolution / Declaration	Share payable in cash	For a consideration other than cash	Share Capital / Allottees Particulars	List of Shareholders after the allotment	Summary of Capital
--------------------------	-----------------------	-------------------------------------	---------------------------------------	--	--------------------

**Particulars of Allottee****Please indicate whether the allottee is an Individual : \***

- Allottee is an Individual  
 Allottee is NOT an Individual ✓

**If Allottee is an Individual :**Shareholder Category : \* **Individual**Identification No. : \*  **Retrieve Details**Identification Type : \*  Name : \* Nationality : \* Mobile No : Occupation : Email Address : 
 Address Type : \*  
 Local  
 Foreign

Local Address (\* if Address Type is Local Address)

Postal Code :  **Retrieve Address**Block/House No. : 

Street Name :

Unit : #  - 

Building/Estate Name :

Foreign Address (\* if Address Type is Foreign Address)

Address : **If Allottee is NOT an Individual :**Shareholder Category : \*  **Search**

Name : **THE CENTRAL DEPOSITORY (PTE) LIMITED**

Address Type : **Local**

Local Address (\* if Address Type is Local Address)

Postal Code : **068804**

Block/House No. : **2**

Street Name : **SHENTON WAY**

Unit : # **19 - 00**

Building/Estate Name : **SGX CENTRE I**

Foreign Address (\* if Address Type is Foreign Address)

Address :

**Details of Shares Allotted** \* Please read instructions carefully before entering.

Note : If any share or shares is/are co-owned by 2 or more persons, please assign an alphabet e.g. A to denote the Group and enter the same in the box. Enter the same alphabet in the box for every allottee in the same group. Skip this box if share(s) are owned by only one person.

Group of Share that is co-owned:  
(Share Group)

If share(s) is/are co-owned, only one allottee is to enter details in (a), (b), (c), (d) and (e). Enter "0" (zero) for subsequent allottees in box (b) and leave blank for rest of the items.

- a) Nominal Value per Share :
- b) No. of shares allotted :
- c) Class of shares allotted :
- d) Currency :
- e) Date of allotment :  (dd/mm/yyyy)

**Return of Allotment of Shares****Submit**

Please fill in the following information. Fields marked \* must be completed.

<b>Resolution / Declaration</b>	<b>Share payable in cash</b>	<b>For a consideration other than cash</b>	<b>Share Capital / Allottees Particulars</b>	<b>List of Shareholders after Allotment</b>	<b>Summary of Capital</b>
-------------------------------------	----------------------------------	--	--	---	-------------------------------

**List of Allottees and their particulars****Identification****No./Registration Name  
No.****Shareholder Category**

198003912M	THE CENTRAL DEPOSITORY (PTE) LIMITED	Company / Foreign Branch
------------	---	--------------------------

If No. of shareholders exceeds 50, total No. of issued shares held by the remaining shareholders are :

	<b>Ordinary</b>	<b>Preference</b>	<b>Others</b>
<b>No. of Shares</b>	<b>0</b>	<b>0</b>	<b>0</b>

**Return of Allotment of Shares****Submit**

Please fill in the following information. Fields marked \* must be completed.

Resolution / Declaration	Share payable in cash	For a consideration other than cash	Share Capital / Allottees Particulars	List of Shareholders after the allotment	Summary of Capital
--------------------------	-----------------------	-------------------------------------	---------------------------------------	--	--------------------

**Share Capital (1)**Currency : **SINGAPORE DOLLAR (099)**Nominal Value per Share : **0.10**Amount of Authorised Share Capital : **200000000.00**

Class of Shares : Ordinary Preference Others

Amount of Issued Share Capital : **102570567.50 0.00 0.00**Amount of Paid-up Share Capital : **102570567.50 0.00 0.00**

GST No. :M9-0008879-T

**RECEIPT**

Receipt No : ACR0000000913666A  
Transaction No : C040489550  
Agency : RCB - RCB  
Application : BIZFILE PAYMENT SERVICE  
Paid via : Deposit Service Account  
EP Ref No :

Date/Time : 28/10/2004 08:50

**SINGAPORE AIRPORT TERMINAL SERVICES LIMITED  
20 AIRPORT BOULEVARD  
SATS INFLIGHT CATERING CENTRE 3  
SINGAPORE 819659**

---

<b>Sno Code/Description</b>	<b>Unit Price (S\$)</b>	<b>Qty</b>	<b>Amount</b>
1 Lodgment Of Return Of Allotment Of Share <b>COMPANY/BUSINESS NAME :</b> 197201770G / SINGAPORE AIRPORT TERMINAL SERVICES LIMITED	10.00	1	10.00
<b>Total (S\$) :</b>			<b>10.00</b>

---

**Deposit Service Account No. : 030066  
Balance Amount in Deposit Account : \$ 85.00**

This is a computer-generated receipt. No signature is required.

Please print a copy of the receipt for your reference.

[HOME](#)[LOGOUT](#)



**Return of Allotment of Shares****Submit**

Please fill in the following information. Fields marked \* must be completed.

Resolution/Declaration	Shares payable in cash	For a consideration other than cash	Share Capital/Allottees Particulars	List of Shareholders after the allotment	Summary of Capital
------------------------	------------------------	-------------------------------------	-------------------------------------	--	--------------------

**Record saved successfully.****Company Type**

Please click on appropriate button :

- company is listed on the securities exchange  
 company is an unlisted public company  
 company is a private company

**Power under Section 161 of the Companies Act \***

The directors have obtained the approval of the company in general meeting to issue shares.

Yes  
 No

**Resolution Made**

\* You are only required to fill in this section if the directors are not given the power under Section 161 of the Companies Act to issue shares.

Registration No. : **197201770G**Company Name : **SINGAPORE AIRPORT TERMINAL SERVICES LIMITED**Nature of Meeting : \* **Directors**

Place of Meeting : \*

Date of Meeting : \* (dd/mm/yyyy)

Resolution Type : \* **Director's**Description : \*  
(max 2000 characters)Attachment : \*  
(copy of resolution)**Note :**

Uploaded file name will be changed by suffixing time-stamp with the actual file name as

**filenameyyyyMMddmmsstt****Browse...**

(Click 'Browse' to select file for attachment)

**Persons signing the resolution**

Please indicate the directors/ secretaries who signed the resolution :

- S0036442H / OW CHIN HOCK
- S0070715E / NG KEE CHOE
- S0234645A / CHEW CHOON SENG
- S1001765C / BARRY HENRY PATRICK DESKER
- S1069567H / TAN JIAK NGEE MICHAEL
- S1673157I / YIP WAI PING ANNABELLE
- S1852301I / HONG HAI @ HUANG HAI
- S2163476Z / CHENG WAI WING EDMUND
- S2580327B / RICHARD CHARLES HELFER

Please enter names of other corporate representatives who signed the resolution, if applicable :

**Declaration**

I, LIM HONG ENG SUSANNA, Professional body/service bureau, declare the information which has been submitted herein to be true to the best of my knowledge.

**Return of Allotment of Shares**

**Submit**

Please fill in the following information. Fields marked \* must be completed.

<u>Resolution / Declaration</u>	<u>Share payable in cash</u>	<u>For a consideration other than cash</u>	<u>Share Capital / Allottees Particulars</u>	<u>List of Shareholders after the Allotment</u>	<u>Summary of Capital</u>
---------------------------------	------------------------------	--	--	---	---------------------------

**Authorised Capital**

	<u>Amount</u>	<u>Nominal Value per Share</u>	<u>Currency</u>
Authorised Capital :	<b>200000000</b>	<b>.1</b>	<b>SINGAPORE DOLLAR ( 099 )</b>

Description of discrepancy :

**Return of Allotment of Shares (Payable in cash) \***

Applicable only if share is payable in cash

<u>Class of Shares :</u>	<u>Ordinary</u>	<u>Preference</u>	<u>Others</u>
Number of shares :	<input type="text" value="5200"/>	<input type="text"/>	<input type="text"/>
Amount paid or due and payable on each share			
paid :	<input type="text" value="0.10"/>	<input type="text"/>	<input type="text"/>
due and payable :	<input type="text" value="0"/>	<input type="text"/>	<input type="text"/>
Amount of premium paid or payable on each share :	<input type="text" value="1.70"/>	<input type="text"/>	<input type="text"/>

**Save**    **Delete Issued Share**    **Reset**    **Back**

**Return of Allotment of Shares**

Submit

Please fill in the following information. Fields marked \* must be completed.

Resolution / Declaration	Share payable in cash	For a consideration other than cash	Share Capital / Allottees Particulars	List of Shareholders after the allotment	Summary of Capital
--------------------------	-----------------------	-------------------------------------	---------------------------------------	--	--------------------

**Particulars of Allottee**

Please indicate whether the allottee is an Individual : \*

- Allottee is an Individual  
 Allottee is NOT an Individual

If Allottee is an Individual :

Shareholder Category : \* **Individual**Identification No. : \*  Retrieve DetailsIdentification Type : \* Name : \* Nationality : \* Mobile No : Occupation : Email Address : Address Type : \*  
 Local  
 Foreign

Local Address (\* if Address Type is Local Address)

Postal Code :  Retrieve AddressBlock/House No. : 

Street Name :

Unit : #  - 

Building/Estate Name :

Foreign Address (\* if Address Type is Foreign Address)

Address : 

If Allottee is NOT an Individual :

Shareholder Category : \*  Search

Registration No. : **198005912M** **THE CENTRAL DEPOSITORY (PTE) LIMITED**

Name : **THE CENTRAL DEPOSITORY (PTE) LIMITED**  
Address Type : **Local**

Local Address (\* if Address Type is Local Address)

Postal Code : **068804**

Block/House No. : **2**

Street Name : **SHENTON WAY**

Unit : # **19 - 00**

Building/Estate Name : **SGX CENTRE I**

Foreign Address (\* if Address Type is Foreign Address)

Address :

**Details of Shares Allotted** \* Please read instructions carefully before entering.

Note : If any share or shares is/are co-owned by 2 or more persons, please assign an alphabet e.g. A to denote the Group and enter the same in the box. Enter the same alphabet in the box for every allottee in the same group. Skip this box if share(s) are owned by only one person.

Group of Share that is co-owned:   
(Share Group)

If share(s) is/are co-owned, only one allottee is to enter details in (a), (b), (c), (d) and (e). Enter "0" (zero) for subsequent allottees in box (b) and leave blank for rest of the items.

- a) Nominal Value per Share :
- b) No. of shares allotted :
- c) Class of shares allotted :
- d) Currency :
- e) Date of allotment :  (dd/mm/yyyy)

**Return of Allotment of Shares****Submit**

Please fill in the following information. Fields marked \* must be completed.

<b>Resolution / Declaration</b>	<b>Share payable in cash</b>	<b>For a consideration other than cash</b>	<b>Share Capital / Allottees Particulars</b>	<b>List of Shareholders after Allotment</b>	<b>Summary of Capital</b>
-------------------------------------	----------------------------------	--	--	---	-------------------------------

**List of Allottees and their particulars****Identification****No./Registration Name  
No.****Shareholder Category**

198003912M	THE CENTRAL DEPOSITORY (PTE) LIMITED	Company / Foreign Branch
------------	---	--------------------------

If No. of shareholders exceeds 50, total No. of issued shares held by the remaining shareholders are :

	<b>Ordinary</b>	<b>Preference</b>	<b>Others</b>
<b>No. of Shares</b>	<b>0</b>	<b>0</b>	<b>0</b>

**Return of Allotment of Shares****Submit**

Please fill in the following information. Fields marked \* must be completed.

<b>Resolution / Declaration</b>	<b>Share payable in cash</b>	<b>For a consideration other than cash</b>	<b>Share Capital / Allottees Particulars</b>	<b>List of Shareholders after the allotment</b>	<b>Summary of Capital</b>
---------------------------------	------------------------------	--	--	---	---------------------------

**Share Capital (1)**

Currency :	<b>SINGAPORE DOLLAR (099)</b>		
Nominal Value per Share :	<b>0.10</b>		
Amount of Authorised Share Capital :	<b>200000000.00</b>		
Class of Shares :	Ordinary	Preference	Others
Amount of Issued Share Capital :	<b>102570307.50</b>	<b>0.00</b>	<b>0.00</b>
Amount of Paid-up Share Capital :	<b>102570307.50</b>	<b>0.00</b>	<b>0.00</b>

GST No. :M9-0008879-T

**RECEIPT**

Receipt No : ACR0000000909032A

Date/Time : 26/10/2004 10:10

Transaction  
No : C040484399

Agency : RCB - RCB

Application : BIZFILE PAYMENT SERVICE

Paid via : Deposit Service Account

EP Ref No :

**SINGAPORE AIRPORT TERMINAL SERVICES LIMITED  
20 AIRPORT BOULEVARD  
SATS INFLIGHT CATERING CENTRE 3  
SINGAPORE 819659**

<b>Sno Code/Description</b>	<b>Unit Price (S\$)</b>	<b>Qty</b>	<b>Amount</b>
1 Lodgment Of Return Of Allotment Of Share <b>COMPANY NAME :</b> 197201770G / SINGAPORE AIRPORT TERMINAL SERVICES LIMITED	10.00	1	10.00
<b>Total (S\$) :</b>			<b>10.00</b>

**Deposit Service Account No. : 030066**  
**Balance Amount in Deposit Account : \$ 95.00**

This is a computer-generated receipt. No signature is required.

Please print a copy of the receipt for your reference.

[HOME](#)[LOGOUT](#)



**Return of Allotment of Shares****Submit**

Please fill in the following information. Fields marked \* must be completed.

Resolution/Declaration	Shares payable in cash	For a consideration other than cash	Share Capital/Allottees Particulars	List of Shareholders after the allotment	Summary of Capital
------------------------	---------------------------	---	---	---	-----------------------

**Record saved successfully.****Company Type**

Please click on appropriate button :

- company is listed on the securities exchange  
 company is an unlisted public company  
 company is a private company

**Power under Section 161 of the Companies Act \***

The directors have obtained the approval of the company in  Yes  No general meeting to issue shares.

**Resolution Made**

\* You are only required to fill in this section if the directors are not given the power under Section 161 of the Companies Act to issue shares.

Registration No. : **197201770G**Company Name : **SINGAPORE AIRPORT TERMINAL SERVICES LIMITED**Nature of Meeting : \*  ▼Place of Meeting : \* Date of Meeting : \*  (dd/mm/yyyy)Resolution Type : \*  ▼Description : \*  
(max 2000 characters)
Attachment : \*  
(copy of resolution)**Note :**

Uploaded file name will be changed by suffixing time-stamp with the actual file name as

**filenameyyyyMMddmmsstt****Browse...**

(Click 'Browse' to select file for attachment)

**Persons signing the resolution**

Please indicate the directors/ secretaries who signed the resolution :

- S0036442H / OW CHIN HOCK
- S0070715E / NG KEE CHOE
- S0234645A / CHEW CHOON SENG
- S1001765C / BARRY HENRY PATRICK DESKER
- S1069567H / TAN JIAK NGEE MICHAEL
- S1673157I / YIP WAI PING ANNABELLE
- S1852301I / HONG HAI @ HUANG HAI
- S2163476Z / CHENG WAI WING EDMUND
- S2580327B / RICHARD CHARLES HELFER

Please enter names of other corporate representatives who signed the resolution, if applicable :

**Declaration**

I, LIM HONG ENG SUSANNA, Professional body/service bureau, declare the information which has been submitted herein to be true to the best of my knowledge.

**Return of Allotment of Shares****Submit**

Please fill in the following information. Fields marked \* must be completed.

Resolution / Declaration	Share payable in cash	For a consideration other than cash	Share Capital / Allottees Particulars	List of Shareholders after the Allotment	Summary of Capital
--------------------------	-----------------------	-------------------------------------	---------------------------------------	--	--------------------

**Authorised Capital**

	Amount	Nominal Value per Share	Currency
Authorised Capital :	<b>20000000</b>	<b>.1</b>	<b>SINGAPORE DOLLAR ( 099 )</b>

Description of discrepancy :

**Return of Allotment of Shares (Payable in cash) \***

Applicable only if share is payable in cash

Class of Shares :	Ordinary	Preference	Others
Number of shares :	<input type="text" value="7700"/>	<input type="text"/>	<input type="text"/>
Amount paid or due and payable on each share			
paid :	<input type="text" value="0.10"/>	<input type="text"/>	<input type="text"/>
due and payable :	<input type="text" value="0"/>	<input type="text"/>	<input type="text"/>
Amount of premium paid or payable on each share :	<input type="text" value="1.50"/>	<input type="text"/>	<input type="text"/>

**Save****Delete Issued Share****Reset****Back**

**Return of Allotment of Shares****Submit**

Please fill in the following information. Fields marked \* must be completed.

<b>Resolution / Declaration</b>	<b>Share payable in cash</b>	<b>For a consideration other than cash</b>	<b>Share Capital / Allottees Particulars</b>	<b>List of Shareholders after the allotment</b>	<b>Summary of Capital</b>
-------------------------------------	----------------------------------	--	--	---	-------------------------------

**Particulars of Allottee**

Please indicate whether the allottee is an Individual : \*

- Allottee is an Individual  
 Allottee is NOT an Individual

If Allottee is an Individual :

Shareholder Category : \* **Individual**Identification No. : \*  **Retrieve Details**Identification Type : \* Name : \* Nationality : \* Mobile No. : Occupation : Email Address : Address Type : \*  
 Local  
 Foreign

Local Address (\* if Address Type is Local Address)

Postal Code :  **Retrieve Address**Block/House No. : 

Street Name :

Unit : #  - 

Building/Estate Name :

Foreign Address (\* if Address Type is Foreign Address)

Address : 

If Allottee is NOT an Individual :

Shareholder Category : \*  **Search**

Name : **THE CENTRAL DEPOSITORY (PTE) LIMITED**

Address Type : **Local**

Local Address (\* if Address Type is Local Address)

Postal Code : **068804**

Block/House No. : **2**

Street Name : **SHENTON WAY**

Unit : # **19 - 00**

Building/Estate Name : **SGX CENTRE I**

Foreign Address (\* if Address Type is Foreign Address)

Address :

**Details of Shares Allotted** \* Please read instructions carefully before entering.

Note : If any share or shares is/are co-owned by 2 or more persons, please assign an alphabet e.g. A to denote the Group and enter the same in the box. Enter the same alphabet in the box for every allottee in the same group. Skip this box if share(s) are owned by only one person.

Group of Share that is co-owned:  
(Share Group)

If share(s) is/are co-owned, only one allottee is to enter details in (a), (b), (c), (d) and (e). Enter "0" (zero) for subsequent allottees in box (b) and leave blank for rest of the items.

a) Nominal Value per Share :

b) No. of shares allotted :

c) Class of shares allotted :

d) Currency :

e) Date of allotment :  (dd/mm/yyyy)

**Return of Allotment of Shares****Submit**

Please fill in the following information. Fields marked \* must be completed.

<b>Resolution / Declaration</b>	<b>Share payable in cash</b>	<b>For a consideration other than cash</b>	<b>Share Capital / Allottees Particulars</b>	<b>List of Shareholders after Allotment</b>	<b>Summary of Capital</b>
-------------------------------------	----------------------------------	--	--	---	-------------------------------

**List of Allottees and their particulars****Identification****No./Registration Name  
No.****Shareholder Category**

198003912M	THE CENTRAL DEPOSITORY (PTE) LIMITED	Company / Foreign Branch
------------	---	--------------------------

If No. of shareholders exceeds 50, total No. of issued shares held by the remaining shareholders are :

<b>No. of Shares</b>	<b>Ordinary</b>	<b>Preference</b>	<b>Others</b>
	0	0	0

**Return of Allotment of Shares****Submit**

Please fill in the following information. Fields marked \* must be completed.

<u>Resolution / Declaration</u>	<u>Share payable in cash</u>	<u>For a consideration other than cash</u>	<u>Share Capital / Allottees Particulars</u>	<u>List of Shareholders after the allotment</u>	<u>Summary of Capital</u>
---------------------------------	------------------------------	--	--	---	---------------------------

**Share Capital (1)**Currency : **SINGAPORE DOLLAR (099)**Nominal Value per Share : **0.10**Amount of Authorised Share Capital : **200000000.00**

Class of Shares : Ordinary Preference Others

Amount of Issued Share Capital : **102569787.50 0.00 0.00**Amount of Paid-up Share Capital : **102569787.50 0.00 0.00**

GST No. :M9-0008879-T

**RECEIPT**

Receipt No : ACR000000908977A

Date/Time : 26/10/2004 09:58

Transaction  
No : C040484340

Agency : RCB - RCB

Application : BIZFILE PAYMENT SERVICE

Paid via : Deposit Service Account

EP Ref No :

**SINGAPORE AIRPORT TERMINAL SERVICES LIMITED  
20 AIRPORT BOULEVARD  
SATS INFLIGHT CATERING CENTRE 3  
SINGAPORE 819659**

<b>Sno Code/Description</b>	<b>Unit Price (S\$)</b>	<b>Qty</b>	<b>Amount</b>
1 Lodgment Of Return Of Allotment Of Share <b>COMPANY NAME :</b> 197201770G / SINGAPORE AIRPORT TERMINAL SERVICES LIMITED	10.00	1	10.00
<b>Total (S\$) :</b>			<b>10.00</b>

**Deposit Service Account No. : 030066**  
**Balance Amount in Deposit Account : \$ 105.00**

This is a computer-generated receipt. No signature is required.

Please print a copy of the receipt for your reference.

[HOME](#)[LOGOUT](#)



**LOCAL COMPANY TRANSACTIONS**[HOME](#) [LOGOUT](#)**Return of Allotment of Shares**[Submit](#)

Please fill in the following information. Fields marked \* must be completed.

Resolution/Declaration	Shares payable in cash	For a consideration other than cash	Share Capital/Allottees Particulars	List of Shareholders after the allotment	Summary of Capital
------------------------	------------------------	-------------------------------------	-------------------------------------	--	--------------------

**Record saved successfully.****Company Type**

Please click on appropriate button :

- company is listed on the securities exchange
- company is an unlisted public company
- company is a private company

**Power under Section 161 of the Companies Act \***

The directors have obtained the approval of the company in general meeting to issue shares.

Yes  
 No

**Resolution Made**

\* You are only required to fill in this section if the directors are not given the power under Section 161 of the Companies Act to issue shares.

Registration No. : **197201770G**Company Name : **SINGAPORE AIRPORT TERMINAL SERVICES LIMITED**Nature of Meeting : \* Place of Meeting : \* Date of Meeting : \*  (dd/mm/yyyy)Resolution Type : \* Description : \*  
(max 2000 characters) Attachment : \*  
(copy of resolution)**Note :**

Uploaded file name will be changed by suffixing time-stamp with the actual file name as

**filenameyyyyMMddmmsstt** [Browse...](#)

(Click 'Browse' to select file for attachment)

**Persons signing the resolution**

Please indicate the directors/ secretaries who signed the resolution :

- S0036442H / OW CHIN HOCK
- S0070715E / NG KEE CHOE
- S0234645A / CHEW CHOON SENG
- S1001765C / BARRY HENRY PATRICK DESKER
- S1069567H / TAN JIAK NGEE MICHAEL
- S1673157I / YIP WAI PING ANNABELLE
- S1852301I / HONG HAI @ HUANG HAI
- S2163476Z / CHENG WAI WING EDMUND
- S2580327B / RICHARD CHARLES HELFER

Please enter names of other corporate representatives who signed the resolution, if applicable :

**Declaration**

I, LIM HONG ENG SUSANNA, Professional body/service bureau, declare the information which has been submitted herein to be true to the best of my knowledge.

**Return of Allotment of Shares**

Submit

Please fill in the following information. Fields marked \* must be completed.

Resolution / Declaration	Share payable in cash	For a consideration other than cash	Share Capital / Allottees Particulars	List of Shareholders after the Allotment	Summary of Capital
--------------------------	-----------------------	-------------------------------------	---------------------------------------	--	--------------------

**Authorised Capital**

	Amount	Nominal Value per Share	Currency
Authorised Capital :	<b>20000000</b>	<b>.1</b>	<b>SINGAPORE DOLLAR ( 099 )</b>

Description of discrepancy :

**Return of Allotment of Shares (Payable in cash) \***

Applicable only if share is payable in cash

Class of Shares :	Ordinary	Preference	Others
Number of shares :	5200		
Amount paid or due and payable on each share			
paid :	0.10		
due and payable :	0		
Amount of premium paid or payable on each share :	1.14		

Save

Delete Issued Share

Reset

Back

**Return of Allotment of Shares****Submit**

Please fill in the following information. Fields marked \* must be completed.

Resolution / Declaration	Share payable in cash	For a consideration other than cash	Share Capital / Allottees Particulars	List of Shareholders after the allotment	Summary of Capital
--------------------------	-----------------------	-------------------------------------	---------------------------------------	--	--------------------

**Particulars of Allottee**

Please indicate whether the allottee is an Individual : \*

- Allottee is an Individual  
 Allottee is NOT an Individual

If Allottee is an Individual :

Shareholder Category : \* **Individual**Identification No. : \*  **Retrieve Details**Identification Type : \* Name : \* Nationality : \* Mobile No : Occupation : Email Address : Address Type : \*  Local  
 Foreign

Local Address (\* if Address Type is Local Address)

Postal Code :  **Retrieve Address**Block/House No. : Street Name : Unit : #  - Building/Estate Name : 

Foreign Address (\* if Address Type is Foreign Address)

Address : 

If Allottee is NOT an Individual :

Shareholder Category : \*  **Search**

Name : **THE CENTRAL DEPOSITORY (PTE) LIMITED**Address Type : **Local**

Local Address (\* if Address Type is Local Address)

Postal Code : **068804**Block/House No. : **2**Street Name : **SHENTON WAY**Unit : # **19 - 00**Building/Estate Name : **SGX CENTRE I**

Foreign Address (\* if Address Type is Foreign Address)

Address :

**Details of Shares Allotted** \* Please read instructions carefully before entering.

Note : If any share or shares is/are co-owned by 2 or more persons, please assign an alphabet e.g. A to denote the Group and enter the same in the box. Enter the same alphabet in the box for every allottee in the same group. Skip this box if share(s) are owned by only one person.

Group of Share that is co-owned:  
(Share Group) 

If share(s) is/are co-owned, only one allottee is to enter details in (a), (b), (c), (d) and (e). Enter "0" (zero) for subsequent allottees in box (b) and leave blank for rest of the items.

- a) Nominal Value per Share :
- b) No. of shares allotted :
- c) Class of shares allotted :
- d) Currency :
- e) Date of allotment :  (dd/mm/yyyy)

**Return of Allotment of Shares****Submit**

Please fill in the following information. Fields marked \* must be completed.

<b>Resolution / Declaration</b>	<b>Share payable in cash</b>	<b>For a consideration other than cash</b>	<b>Share Capital / Allottees Particulars</b>	<b>List of Shareholders after Allotment</b>	<b>Summary of Capital</b>
-------------------------------------	----------------------------------	--	--	---	-------------------------------

**List of Allottees and their particulars****Identification****No./Registration Name  
No.****Shareholder Category**

198003912M	THE CENTRAL DEPOSITORY (PTE) LIMITED	Company / Foreign Branch
------------	---	--------------------------

If No. of shareholders exceeds 50, total No. of issued shares held by the remaining shareholders are :

	<b>Ordinary</b>	<b>Preference</b>	<b>Others</b>
<b>No. of Shares</b>	<b>0</b>	<b>0</b>	<b>0</b>

**Return of Allotment of Shares**

Please fill in the following information. Fields marked \* must be completed.

<u>Resolution / Declaration</u>	<u>Share payable in cash</u>	<u>For a consideration other than cash</u>	<u>Share Capital / Allottees Particulars</u>	<u>List of Shareholders after the allotment</u>	<u>Summary of Capital</u>
-------------------------------------	----------------------------------	--	--	---	-------------------------------

**Share Capital (1)**

Currency :	<b>SINGAPORE DOLLAR (099)</b>		
Nominal Value per Share :	<b>0.10</b>		
Amount of Authorised Share Capital :	<b>200000000.00</b>		
Class of Shares :	Ordinary	Preference	Others
Amount of Issued Share Capital :	<b>102569017.50</b>	<b>0.00</b>	<b>0.00</b>
Amount of Paid-up Share Capital :	<b>102569017.50</b>	<b>0.00</b>	<b>0.00</b>

GST No. :M9-0008879-T

**RECEIPT**

Receipt No : ACR0000000908942A

Date/Time : 26/10/2004 09:50

Transaction  
No : C040484303

Agency : RCB - RCB

Application : BIZFILE PAYMENT SERVICE

Paid via : Deposit Service Account

EP Ref No :

**SINGAPORE AIRPORT TERMINAL SERVICES LIMITED  
20 AIRPORT BOULEVARD  
SATS INFLIGHT CATERING CENTRE 3  
SINGAPORE 819659**

---

<b>Sno Code/Description</b>	<b>Unit Price (S\$)</b>	<b>Qty</b>	<b>Amount</b>
1 Lodgment Of Return Of Allotment Of Share <b>COMPANY NAME :</b> 197201770G / SINGAPORE AIRPORT TERMINAL SERVICES LIMITED	10.00	1	10.00
<b>Total (S\$) :</b>			<b>10.00</b>

---

**Deposit Service Account No. : 030066**  
**Balance Amount in Deposit Account : \$ 115.00**

This is a computer-generated receipt. No signature is required.

Please print a copy of the receipt for your reference.

[HOME](#)[LOGOUT](#)



**Return of Allotment of Shares**

Submit

Please fill in the following information. Fields marked \* must be completed.

Resolution/Declaration	Shares payable in cash	For a consideration other than cash	Share Capital/Allottees Particulars	List of Shareholders after the allotment	Summary of Capital
------------------------	---------------------------	---	---	---	-----------------------

**Record saved successfully.****Company Type**

Please click on appropriate button :

- company is listed on the securities exchange  
 company is an unlisted public company  
 company is a private company

**Power under Section 161 of the Companies Act \***

The directors have obtained  
the approval of the company in  Yes  
general meeting to issue  No  
shares.

**Resolution Made**

\* You are only required to fill in this section if the directors are not given the power under Section 161 of the Companies Act to issue shares.

Registration No. : **197201770G**Company Name : **SINGAPORE AIRPORT TERMINAL SERVICES LIMITED**

Nature of Meeting : \* Directors

Place of Meeting : \*

Date of Meeting : \* (dd/mm/yyyy)

Resolution Type : \* Director's

Description : \*  
(max 2000 characters)Attachment : \*  
(copy of resolution)**Note :**

Uploaded file name will be  
changed by suffixing time-  
stamp with the actual file  
name as

filenameyyyyMMddmmsstt

Browse...

(Click 'Browse' to select file for attachment)

**Persons signing the resolution**

Please indicate the directors/ secretaries who signed the resolution :

- S0036442H / OW CHIN HOCK
- S0070715E / NG KEE CHOE
- S0234645A / CHEW CHOON SENG
- S1001765C / BARRY HENRY PATRICK DESKER
- S1069567H / TAN JIAK NGEE MICHAEL
- S1673157I / YIP WAI PING ANNABELLE
- S1852301I / HONG HAI @ HUANG HAI
- S2163476Z / CHENG WAI WING EDMUND
- S2580327B / RICHARD CHARLES HELFER

Please enter names of other corporate representatives who signed the resolution, if applicable :

**Declaration**

I, LIM HONG ENG SUSANNA, Professional body/service bureau, declare the information which has been submitted herein to be true to the best of my knowledge.

**Return of Allotment of Shares****Submit**

Please fill in the following information. Fields marked \* must be completed.

<u>Resolution / Declaration</u>	<u>Share payable in cash</u>	<u>For a consideration other than cash</u>	<u>Share Capital / Allottees Particulars</u>	<u>List of Shareholders after the Allotment</u>	<u>Summary of Capital</u>
---------------------------------	------------------------------	--	--	---	---------------------------

**Authorised Capital**

	Amount	Nominal Value per Share	Currency
Authorised Capital :	<b>200000000</b>	<b>.1</b>	<b>SINGAPORE DOLLAR ( 099 )</b>

Description of discrepancy :

**Return of Allotment of Shares (Payable in cash) \***

Applicable only if share is payable in cash

Class of Shares :	Ordinary	Preference	Others
Number of shares :	<input type="text" value="5200"/>	<input type="text"/>	<input type="text"/>
Amount paid or due and payable on each share			
paid :	<input type="text" value="0.10"/>	<input type="text"/>	<input type="text"/>
due and payable :	<input type="text" value="0"/>	<input type="text"/>	<input type="text"/>
Amount of premium paid or payable on each share :	<input type="text" value="1.70"/>	<input type="text"/>	<input type="text"/>

<b>Save</b>	<b>Delete Issued Share</b>	<b>Reset</b>	<b>Back</b>
-------------	----------------------------	--------------	-------------

**Return of Allotment of Shares**

Submit

Please fill in the following information. Fields marked \* must be completed.

Resolution / Declaration	Share payable in cash	For a consideration other than cash	Share Capital / Allottees Particulars	List of Shareholders after the allotment	Summary of Capital
--------------------------	-----------------------	-------------------------------------	---------------------------------------	--	--------------------

**Particulars of Allottee**

Please indicate whether the allottee is an Individual : \*

- Allottee is an Individual  
 Allottee is NOT an Individual

If Allottee is an Individual :

Shareholder Category : \* **Individual**

Identification No. : \*

Retrieve Details

Identification Type : \*

NRIC 

Name : \*

Nationality : \*

Mobile No :

Occupation :

Email Address :

Address Type : \*

- Local  
 Foreign

Local Address (\* if Address Type is Local Address)

Postal Code :

Retrieve Address

Block/House No. :

Street Name :

Unit : #

 - 

Building/Estate Name :

Foreign Address (\* if Address Type is Foreign Address)

Address :

If Allottee is NOT an Individual :

Shareholder Category : \*

Company / Foreign Branch 

Search

Name : **THE CENTRAL DEPOSITORY (PTE) LIMITED**

Address Type : **Local**

Local Address (\* if Address Type is Local Address)

Postal Code : **068804**

Block/House No. : **2**

Street Name : **SHENTON WAY**

Unit : # **19 - 00**

Building/Estate Name : **SGX CENTRE I**

Foreign Address (\* if Address Type is Foreign Address)

Address :

**Details of Shares Allotted** \* Please read instructions carefully before entering.

Note : If any share or shares is/are co-owned by 2 or more persons, please assign an alphabet e.g. A to denote the Group and enter the same in the box. Enter the same alphabet in the box for every allottee in the same group. Skip this box if share(s) are owned by only one person.

Group of Share that is co-owned:  
(Share Group)

If share(s) is/are co-owned, only one allottee is to enter details in (a), (b), (c), (d) and (e). Enter "0" (zero) for subsequent allottees in box (b) and leave blank for rest of the items.

- a) Nominal Value per Share :  ✓
- b) No. of shares allotted :  ✓
- c) Class of shares allotted :  ▼
- d) Currency :  ▼
- e) Date of allotment :  (dd/mm/yyyy) ✓

**Return of Allotment of Shares**[Submit](#)

Please fill in the following information. Fields marked \* must be completed.

<b>Resolution / Declaration</b>	<b>Share payable in cash</b>	<b>For a consideration other than cash</b>	<b>Share Capital / Allottees Particulars</b>	<b>List of Shareholders after Allotment</b>	<b>Summary of Capital</b>
-------------------------------------	----------------------------------	--	--	---	-------------------------------

**List of Allottees and their particulars****Identification****No./Registration Name  
No.****Shareholder Category**

198003912M	THE CENTRAL DEPOSITORY (PTE) LIMITED	Company / Foreign Branch
------------	---	--------------------------

If No. of shareholders exceeds 50, total No. of issued shares held by the remaining shareholders are :

	<b>Ordinary</b>	<b>Preference</b>	<b>Others</b>
<b>No. of Shares</b>	<b>0</b>	<b>0</b>	<b>0</b>

**Return of Allotment of Shares****Submit**

Please fill in the following information. Fields marked \* must be completed.

<u>Resolution / Declaration</u>	<u>Share payable in cash</u>	<u>For a consideration other than cash</u>	<u>Share Capital / Allottees Particulars</u>	<u>List of Shareholders after the allotment</u>	<u>Summary of Capital</u>
---------------------------------	------------------------------	--	--	---	---------------------------

**Share Capital (1)**

Currency :	<b>SINGAPORE DOLLAR (099)</b>		
Nominal Value per Share :	<b>0.10</b>		
Amount of Authorised Share Capital :	<b>200000000.00</b>		
Class of Shares :	Ordinary	Preference	Others
Amount of Issued Share Capital :	<b>102568497.50</b>	<b>0.00</b>	<b>0.00</b>
Amount of Paid-up Share Capital :	<b>102568497.50</b>	<b>0.00</b>	<b>0.00</b>

GST No. :M9-0008879-T

**RECEIPT**

Receipt No : ACR0000000906969A

Date/Time : 25/10/2004 09:48

Transaction No : C040482161

Agency : RCB - RCB

Application : BIZFILE PAYMENT SERVICE

Paid via : Deposit Service Account

EP Ref No :

**SINGAPORE AIRPORT TERMINAL SERVICES LIMITED**  
**20 AIRPORT BOULEVARD**  
**SATS INFLIGHT CATERING CENTRE 3**  
**SINGAPORE 819659**

<b>Sno Code/Description</b>	<b>Unit Price (\$)</b>	<b>Qty</b>	<b>Amount</b>
1 Lodgment Of Return Of Allotment Of Share <b>COMPANY NAME :</b> 197201770G / SINGAPORE AIRPORT TERMINAL SERVICES LIMITED	10.00	1	10.00
<b>Total (\$):</b>			<b>10.00</b>

**Deposit Service Account No. : 030066**  
**Balance Amount in Deposit Account : \$ 125.00**

This is a computer-generated receipt. No signature is required.

Please print a copy of the receipt for your reference.

[HOME](#)[LOGOUT](#)



**Return of Allotment of Shares**

Submit

Please fill in the following information. Fields marked \* must be completed.

Resolution/Declaration	Shares payable in cash	For a consideration other than cash	Share Capital/Allottees Particulars	List of Shareholders after the allotment	Summary of Capital
------------------------	---------------------------	---	---	---	-----------------------

**Record saved successfully.****Company Type**

Please click on appropriate button :

- company is listed on the securities exchange
- company is an unlisted public company
- company is a private company

**Power under Section 161 of the Companies Act \***

The directors have obtained  
the approval of the company in  Yes  
general meeting to issue  No  
shares.

**Resolution Made**

\* You are only required to fill in this section if the directors are not given the power under Section 161 of the Companies Act to issue shares.

Registration No. : **197201770G**Company Name : **SINGAPORE AIRPORT TERMINAL SERVICES LIMITED**

Nature of Meeting : \* Directors

Place of Meeting : \*

Date of Meeting : \* (dd/mm/yyyy)

Resolution Type : \* Director's

Description : \*  
(max 2000 characters)Attachment : \*  
(copy of resolution)**Note :**

Uploaded file name will be  
changed by suffixing time-  
stamp with the actual file  
name as

filenameyyyyMMddmmsstt

Browse...

(Click 'Browse' to select file for attachment)

**Persons signing the resolution**

Please indicate the directors/ secretaries who signed the resolution :

- S0036442H / OW CHIN HOCK
- S0070715E / NG KEE CHOE
- S0234645A / CHEW CHOON SENG
- S1001765C / BARRY HENRY PATRICK DESKER
- S1069567H / TAN JIAK NGEE MICHAEL
- S1673157I / YIP WAI PING ANNABELLE
- S1852301I / HONG HAI @ HUANG HAI
- S2163476Z / CHENG WAI WING EDMUND
- S2580327B / RICHARD CHARLES HELFER

Please enter names of other corporate representatives who signed the resolution, if applicable :

**Declaration**

I, LIM HONG ENG SUSANNA, Professional body/service bureau, declare the information which has been submitted herein to be true to the best of my knowledge.

**Return of Allotment of Shares****Submit**

Please fill in the following information. Fields marked \* must be completed.

<b>Resolution / Declaration</b>	<b>Share payable in cash</b>	<b>For a consideration other than cash</b>	<b>Share Capital / Allottees Particulars</b>	<b>List of Shareholders after the Allotment</b>	<b>Summary of Capital</b>
-------------------------------------	----------------------------------	--	--	---	-------------------------------

**Authorised Capital**

	<b>Amount</b>	<b>Nominal Value per Share</b>	<b>Currency</b>
<b>Authorised Capital :</b>	<b>200000000</b>	<b>.1</b>	<b>SINGAPORE DOLLAR ( 099 )</b>

Description of discrepancy :

**Return of Allotment of Shares (Payable in cash) \***

Applicable only if share is payable in cash

<b>Class of Shares :</b>	<b>Ordinary</b>	<b>Preference</b>	<b>Others</b>
<b>Number of shares :</b>	<input type="text" value="18800"/>	<input type="text"/>	<input type="text"/>
<b>Amount paid or due and payable on each share</b>			
<b>paid :</b>	<input type="text" value="0.10"/>	<input type="text"/>	<input type="text"/>
<b>due and payable :</b>	<input type="text" value="0"/>	<input type="text"/>	<input type="text"/>
<b>Amount of premium paid or payable on each share :</b>	<input type="text" value="1.50"/>	<input type="text"/>	<input type="text"/>

**Save** **Delete Issued Share** **Reset** **Back**

**Return of Allotment of Shares****Submit**

Please fill in the following information. Fields marked \* must be completed.

Resolution / Declaration	Share payable in cash	For a consideration other than cash	Share Capital / Allottees Particulars	List of Shareholders after the allotment	Summary of Capital
--------------------------	-----------------------	-------------------------------------	---------------------------------------	--	--------------------

**Particulars of Allottee**

Please indicate whether the allottee is an Individual : \*

- Allottee is an Individual  
 Allottee is NOT an Individual

If Allottee is an Individual :

Shareholder Category : \* **Individual**Identification No. : \*  **Retrieve Details**Identification Type : \*  Name : \* Nationality : \*  Mobile No : Occupation : Email Address : Address Type : \*  
 Local  
 Foreign

Local Address (\* if Address Type is Local Address)

Postal Code :  **Retrieve Address**Block/House No. :  Street Name : Unit : #  - Building/Estate Name : 

Foreign Address (\* if Address Type is Foreign Address)

Address : 

If Allottee is NOT an Individual :

Shareholder Category : \*   **Search**

Registration No.: \*

198003912M

Retrieve Details

Name :

**THE CENTRAL DEPOSITORY (PTE) LIMITED**

Address Type :

**Local**

Local Address (\* if Address Type is Local Address)

Postal Code : **068804**

Block/House No. : **2**

Street Name : **SHENTON WAY**

Unit : # **19 - 00**

Building/Estate Name : **SGX CENTRE I**

Foreign Address (\* if Address Type is Foreign Address)

Address :

**Details of Shares Allotted** \* Please read instructions carefully before entering.

Note : If any share or shares is/are co-owned by 2 or more persons, please assign an alphabet e.g. A to denote the Group and enter the same in the box. Enter the same alphabet in the box for every allottee in the same group. Skip this box if share(s) are owned by only one person.

Group of Share that is co-owned:  
(Share Group)

If share(s) is/are co-owned, only one allottee is to enter details in (a), (b), (c), (d) and (e). Enter "0" (zero) for subsequent allottees in box (b) and leave blank for rest of the items.

a) Nominal Value per Share :

0.10

b) No. of shares allotted :

18800

c) Class of shares allotted :

Ordinary

d) Currency :

SINGAPORE DOLLAR (099)

e) Date of allotment :

20/10/2004 (dd/mm/yyyy)

Save

Reset

Back

**Return of Allotment of Shares****Submit**

Please fill in the following information. Fields marked \* must be completed.

<b>Resolution / Declaration</b>	<b>Share payable in cash</b>	<b>For a consideration other than cash</b>	<b>Share Capital / Allottees Particulars</b>	<b>List of Shareholders after Allotment</b>	<b>Summary of Capital</b>
-------------------------------------	----------------------------------	--	--	---	-------------------------------

**List of Allottees and their particulars****Identification****No./Registration Name  
No.****Shareholder Category**

198003912M	THE CENTRAL DEPOSITORY (PTE) LIMITED	Company / Foreign Branch
------------	---	--------------------------

If No. of shareholders exceeds 50, total No. of issued shares held by the remaining shareholders are :

<b>No. of Shares</b>	<b>Ordinary</b>	<b>Preference</b>	<b>Others</b>
	0	0	0

**Return of Allotment of Shares**

Submit

Please fill in the following information. Fields marked \* must be completed.

Resolution / Declaration	Share payable in cash	For a consideration other than cash	Share Capital / Allottees Particulars	List of Shareholders after the allotment	Summary of Capital
<b>Share Capital (1)</b>					
Currency :	<b>SINGAPORE DOLLAR (099)</b>				
Nominal Value per Share :	<b>0.10</b>				
Amount of Authorised Share Capital :	<b>200000000.00</b>				
Class of Shares :	Ordinary	Preference	Others		
Amount of Issued Share Capital :	<b>102567977.50</b>	<b>0.00</b>	<b>0.00</b>		
Amount of Paid-up Share Capital :	<b>102567977.50</b>	<b>0.00</b>	<b>0.00</b>		

GST No. :M9-0008879-T

**RECEIPT**

Receipt No : ACR0000000906949A

Date/Time : 25/10/2004 09:40

Transaction  
No : C040482143

Agency : RCB - RCB

Application : BIZFILE PAYMENT SERVICE

Paid via : Deposit Service Account

EP Ref No :

**SINGAPORE AIRPORT TERMINAL SERVICES LIMITED**  
**20 AIRPORT BOULEVARD**  
**SATS INFLIGHT CATERING CENTRE 3**  
**SINGAPORE 819659**

---

<b>Sno Code/Description</b>	<b>Unit Price (S\$)</b>	<b>Qty</b>	<b>Amount</b>
1 Lodgment Of Return Of Allotment Of Share <b>COMPANY NAME :</b> 197201770G / SINGAPORE AIRPORT TERMINAL SERVICES LIMITED	10.00	1	10.00
<b>Total (S\$) :</b>			<b>10.00</b>

---

**Deposit Service Account No. : 030066**  
**Balance Amount in Deposit Account : \$ 135.00**

This is a computer-generated receipt. No signature is required.

Please print a copy of the receipt for your reference.

[HOME](#)[LOGOUT](#)



**Return of Allotment of Shares**

Submit

Please fill in the following information. Fields marked \* must be completed.

Resolution/Declaration	Shares payable in cash	For a consideration <u>other than cash</u>	Share Capital/Allottees Particulars	List of Shareholders after the allotment	Summary of Capital
------------------------	---------------------------	--	---	---	-----------------------

Record saved successfully.

**Company Type**

Please click on appropriate button :

- company is listed on the securities exchange
- company is an unlisted public company
- company is a private company

**Power under Section 161 of the Companies Act \***

The directors have obtained  
the approval of the company in  Yes  
general meeting to issue  No  
shares.

**Resolution Made**

\* You are only required to fill in this section if the directors are not given the power under Section 161 of the Companies Act to issue shares.

Registration No. : **197201770G**Company Name : **SINGAPORE AIRPORT TERMINAL SERVICES LIMITED**

Nature of Meeting : \* Directors

Place of Meeting : \*

Date of Meeting : \* (dd/mm/yyyy)

Resolution Type : \* Director's

Description : \*  
(max 2000 characters)Attachment : \*  
(copy of resolution)**Note :**

Uploaded file name will be  
changed by suffixing time-  
stamp with the actual file  
name as

filenameyyyyMMddmmsstt

Browse...

(Click 'Browse' to select file for attachment)

**Persons signing the resolution**

Please indicate the directors/ secretaries who signed the resolution :

- S0036442H / OW' CHIN HOCK
- S0070715E / NG KEE CHOE
- S0234645A / CHEW CHOON SENG
- S1001765C / BARRY HENRY PATRICK DESKER
- S1069567H / TAN JIAK NGEE MICHAEL
- S1673157I / YIP WAI PING ANNABELLE
- S1852301I / HONG HAI @ HUANG HAI
- S2163476Z / CHENG WAI WING EDMUND
- S2580327B / RICHARD CHARLES HELFER

Please enter names of other corporate representatives who signed the resolution, if applicable :

**Declaration**

I, LIM HONG ENG SUSANNA, Professional body/service bureau, declare the information which has been submitted herein to be true to the best of my knowledge.

**Return of Allotment of Shares**

**Submit**

Please fill in the following information. Fields marked \* must be completed.

<u>Resolution / Declaration</u>	<u>Share payable in cash</u>	<u>For a consideration other than cash</u>	<u>Share Capital / Allottees Particulars</u>	<u>List of Shareholders after the Allotment</u>	<u>Summary of Capital</u>
---------------------------------	------------------------------	--	--	---	---------------------------

**Authorised Capital**

	<u>Amount</u>	<u>Nominal Value per Share</u>	<u>Currency</u>
Authorised Capital :	<b>200000000</b>	<b>.1</b>	<b>SINGAPORE DOLLAR ( 099 )</b>

Description of discrepancy :

**Return of Allotment of Shares (Payable in cash) \***

Applicable only if share is payable in cash

<u>Class of Shares :</u>	<u>Ordinary</u>	<u>Preference</u>	<u>Others</u>
Number of shares :	<input type="text" value="10400"/>	<input type="text"/>	<input type="text"/>
Amount paid or due and payable on each share			
paid :	<input type="text" value="0.10"/>	<input type="text"/>	<input type="text"/>
due and payable :	<input type="text" value="0"/>	<input type="text"/>	<input type="text"/>
Amount of premium paid or payable on each share :	<input type="text" value="1.14"/>	<input type="text"/>	<input type="text"/>

**Save**    **Delete Issued Share**    **Reset**    **Back**

**Return of Allotment of Shares****Submit**

Please fill in the following information. Fields marked \* must be completed.

Resolution / Declaration	Share payable in cash	For a consideration other than cash	Share Capital / Allottees Particulars	List of Shareholders after the allotment	Summary of Capital
--------------------------	-----------------------	-------------------------------------	---------------------------------------	--	--------------------

**Particulars of Allottee**

Please indicate whether the allottee is an Individual : \*

- Allottee is an Individual  
 Allottee is NOT an Individual

**If Allottee is an Individual :**Shareholder Category : \* **Individual**

Identification No. : \*

**Retrieve Details**

Identification Type : \*

Name : \*

Nationality : \*

Mobile No :

Occupation :

Email Address :

Address Type : \*

- Local  
 Foreign

Local Address (\* if Address Type is Local Address)

Postal Code :

**Retrieve Address**

Block/House No. :

Street Name :

Unit : #

 - 

Building/Estate Name :

Foreign Address (\* if Address Type is Foreign Address)

Address :

**If Allottee is NOT an Individual :**

Shareholder Category : \*

**Search**

Registration No. : \*

198003912M

Retrieve Details

Name : **THE CENTRAL DEPOSITORY (PTE) LIMITED**

Address Type : **Local**

Local Address (\* if Address Type is Local Address)

Postal Code : **068804**

Block/House No. : **2**

Street Name : **SHENTON WAY**

Unit : # **19 - 00**

Building/Estate Name : **SGX CENTRE I**

Foreign Address (\* if Address Type is Foreign Address)

Address :

**Details of Shares Allotted** \* Please read instructions carefully before entering.

Note : If any share or shares is/are co-owned by 2 or more persons, please assign an alphabet e.g. A to denote the Group and enter the same in the box. Enter the same alphabet in the box for every allottee in the same group. Skip this box if share(s) are owned by only one person.

Group of Share that is co-owned:  
(Share Group)

If share(s) is/are co-owned, only one allottee is to enter details in (a), (b), (c), (d) and (e). Enter "0" (zero) for subsequent allottees in box (b) and leave blank for rest of the items.

a) Nominal Value per Share :

0.10

b) No. of shares allotted :

10400

c) Class of shares allotted :

Ordinary

d) Currency :

SINGAPORE DOLLAR (099)

e) Date of allotment :

20/10/2004 (dd/mm/yyyy)

Save

Reset

Back

**Return of Allotment of Shares****Submit**

Please fill in the following information. Fields marked \* must be completed.

<b>Resolution / Declaration</b>	<b>Share payable in cash</b>	<b>For a consideration other than cash</b>	<b>Share Capital / Allottees Particulars</b>	<b>List of Shareholders after Allotment</b>	<b>Summary of Capital</b>
-------------------------------------	----------------------------------	--	--	---	-------------------------------

**List of Allottees and their particulars****Identification****No./Registration Name  
No.****Shareholder Category**

198003912M	THE CENTRAL DEPOSITORY (PTE) LIMITED	Company / Foreign Branch
------------	---	--------------------------

If No. of shareholders exceeds 50, total No. of issued shares held by the remaining shareholders are :

	<b>Ordinary</b>	<b>Preference</b>	<b>Others</b>
<b>No. of Shares</b>	<b>0</b>	<b>0</b>	<b>0</b>

**Return of Allotment of Shares**

**Submit**

Please fill in the following information. Fields marked \* must be completed.

<b>Resolution / Declaration</b>	<b>Share payable in cash</b>	<b>For a consideration other than cash</b>	<b>Share Capital / Allottees Particulars</b>	<b>List of Shareholders after the allotment</b>	<b>Summary of Capital</b>
---------------------------------	------------------------------	--	--	---	---------------------------

**Share Capital (1)**

Currency :	<b>SINGAPORE DOLLAR (099)</b>		
Nominal Value per Share :	<b>0.10</b>		
Amount of Authorised Share Capital :	<b>200000000.00</b>		
Class of Shares :	Ordinary	Preference	Others
Amount of Issued Share Capital :	<b>102566097.50</b>	<b>0.00</b>	<b>0.00</b>
Amount of Paid-up Share Capital :	<b>102566097.50</b>	<b>0.00</b>	<b>0.00</b>

GST No. :M9-0008879-T

**RECEIPT**

Receipt No : ACR0000000904841A

Date/Time : 22/10/2004 12:02

Transaction No : C040479806

Agency : RCB - RCB

Application : BIZFILE PAYMENT SERVICE

Paid via : Deposit Service Account

EP Ref No :

**SINGAPORE AIRPORT TERMINAL SERVICES LIMITED  
20 AIRPORT BOULEVARD  
SATS INFLIGHT CATERING CENTRE 3  
SINGAPORE 819659**

---

<b>Sno Code/Description</b>	<b>Unit Price (S\$)</b>	<b>Qty</b>	<b>Amount</b>
1 Lodgment Of Return Of Allotment Of Share <b>COMPANY NAME :</b> 197201770G / SINGAPORE AIRPORT TERMINAL SERVICES LIMITED	10.00	1	10.00
<b>Total (S\$) :</b>			<b>10.00</b>

---

**Deposit Service Account No. : 030066**  
**Balance Amount in Deposit Account : \$ 145.00**

This is a computer-generated receipt. No signature is required.

Please print a copy of the receipt for your reference.

[HOME](#)[LOGOUT](#)



**Return of Allotment of Shares**

Submit

Please fill in the following information. Fields marked \* must be completed.

Resolution/Declaration	Shares payable in cash	For a consideration other than cash	Share Capital/Allottees Particulars	List of Shareholders after the allotment	Summary of Capital
------------------------	---------------------------	---	---	---	-----------------------

Record saved successfully.

**Company Type**

Please click on appropriate button :

- company is listed on the securities exchange
- company is an unlisted public company
- company is a private company

**Power under Section 161 of the Companies Act \***

The directors have obtained  
the approval of the company in  Yes  
general meeting to issue  No  
shares.

**Resolution Made**

\* You are only required to fill in this section if the directors are not given the power under Section 161 of the Companies Act to issue shares.

Registration No. : **197201770G**Company Name : **SINGAPORE AIRPORT TERMINAL SERVICES LIMITED**

Nature of Meeting : \* Directors

Place of Meeting : \*

Date of Meeting : \* (dd/mm/yyyy)

Resolution Type : \* Director's

Description : \*  
(max 2000 characters)Attachment : \*  
(copy of resolution)**Note :**

Uploaded file name will be  
changed by suffixing time-  
stamp with the actual file  
name as

filenameyyyyMMddmsstt

Browse...

(Click 'Browse' to select file for attachment)

**Persons signing the resolution**

Please indicate the directors/ secretaries who signed the resolution :

- S0036442H / OW CHIN HOCK
- S0070715E / NG KEE CHOE
- S0234645A / CHEW CHOON SENG
- S1001765C / BARRY HENRY PATRICK DESKER
- S1069567H / TAN JIAK NGEE MICHAEL
- S1673157I / YIP WAI PING ANNABELLE
- S1852301I / HONG HAI @ HUANG HAI
- S2163476Z / CHENG WAI WING EDMUND
- S2580327B / RICHARD CHARLES HELFER

Please enter names of other corporate representatives who signed the resolution, if applicable :

**Declaration**

I, LIM HONG ENG SUSANNA, Professional body/service bureau, declare the information which has been submitted herein to be true to the best of my knowledge.

**Return of Allotment of Shares**

Submit

Please fill in the following information. Fields marked \* must be completed.

Resolution / Declaration	Share payable in cash	For a consideration other than cash	Share Capital / Allottees Particulars	List of Shareholders after the Allotment	Summary of Capital
--------------------------	-----------------------	-------------------------------------	---------------------------------------	--	--------------------

**Authorised Capital**

	Amount	Nominal Value per Share	Currency
Authorised Capital :	<b>20000000</b>	<b>.1</b>	<b>SINGAPORE DOLLAR ( 099 )</b>

Description of discrepancy :

**Return of Allotment of Shares (Payable in cash) \***

Applicable only if share is payable in cash

Class of Shares :	Ordinary	Preference	Others
Number of shares :	13000		
Amount paid or due and payable on each share			
paid :	0.10		
due and payable :	0		
Amount of premium paid or payable on each share :	1.50		

Save Delete Issued Share Reset Back

**Return of Allotment of Shares**

Submit

Please fill in the following information. Fields marked \* must be completed.

<u>Resolution / Declaration</u>	<u>Share payable in cash</u>	<u>For a consideration other than cash</u>	<u>Share Capital / Allottees Particulars</u>	<u>List of Shareholders after the allotment</u>	<u>Summary of Capital</u>
-------------------------------------	----------------------------------	--	--	---	-------------------------------

**Particulars of Allottee**

Please indicate whether the allottee is an Individual : \*

- Allottee is an Individual  
 Allottee is NOT an Individual

If Allottee is an Individual :

Shareholder Category : \* **Individual**Identification No. : \*  Retrieve DetailsIdentification Type : \*  ▼Name : \* Nationality : \*  ▼Mobile No : Occupation : Email Address : Address Type : \*  
 Local  
 Foreign

Local Address (\* if Address Type is Local Address)

Postal Code :  Retrieve AddressBlock/House No. :  ▼

Street Name :

Unit : #  - 

Building/Estate Name :

Foreign Address (\* if Address Type is Foreign Address)

Address : 

If Allottee is NOT an Individual :

Shareholder Category : \*  ▼ Search

Registration No. : \*

198003912M

Retrieve Details

Name :

**THE CENTRAL DEPOSITORY (PTE) LIMITED**

Address Type :

**Local**

Local Address (\* if Address Type is Local Address)

Postal Code : **068804**

Block/House No. : **2**

Street Name : **SHENTON WAY**

Unit : # **19 - 00**

Building/Estate Name : **SGX CENTRE I**

Foreign Address (\* if Address Type is Foreign Address)

Address :

**Details of Shares Allotted** \* Please read instructions carefully before entering.

Note : If any share or shares is/are co-owned by 2 or more persons, please assign an alphabet e.g. A to denote the Group and enter the same in the box. Enter the same alphabet in the box for every allottee in the same group. Skip this box if share(s) are owned by only one person.

Group of Share that is co-owned:  
(Share Group)

If share(s) is/are co-owned, only one allottee is to enter details in (a), (b), (c), (d) and (e). Enter "0" (zero) for subsequent allottees in box (b) and leave blank for rest of the items.

a) Nominal Value per Share :

0.10

b) No. of shares allotted :

13000

c) Class of shares allotted :

Ordinary

d) Currency :

SINGAPORE DOLLAR (099)

e) Date of allotment :

19/10/2004 (dd/mm/yyyy)

Save

Reset

Back

**Return of Allotment of Shares****Submit**

Please fill in the following information. Fields marked \* must be completed.

<b>Resolution / Declaration</b>	<b>Share payable in cash</b>	<b>For a consideration other than cash</b>	<b>Share Capital / Allottees Particulars</b>	<b>List of Shareholders after Allotment</b>	<b>Summary of Capital</b>
-------------------------------------	----------------------------------	--	--	---	-------------------------------

**List of Allottees and their particulars****Identification****No./Registration Name  
No.****Shareholder Category**

198003912M	THE CENTRAL DEPOSITORY (PTE) LIMITED	Company / Foreign Branch
------------	---	--------------------------

If No. of shareholders exceeds 50, total No. of issued shares held by the remaining shareholders are :

<b>No. of Shares</b>	<b>Ordinary</b>	<b>Preference</b>	<b>Others</b>
	0	0	0

**Return of Allotment of Shares****Submit**

Please fill in the following information. Fields marked \* must be completed.

<u>Resolution / Declaration</u>	<u>Share payable in cash</u>	<u>For a consideration other than cash</u>	<u>Share Capital / Allottees Particulars</u>	<u>List of Shareholders after the allotment</u>	<u>Summary of Capital</u>
---------------------------------	------------------------------	--	--	---	---------------------------

**Share Capital (1)**

Currency :	<b>SINGAPORE DOLLAR (099)</b>			
Nominal Value per Share :	<b>0.10</b>			
Amount of Authorised Share Capital :	<b>200000000.00</b>			
Class of Shares :	Ordinary	Preference	Others	
Amount of Issued Share Capital :	<b>102565057.50</b>	<b>0.00</b>	<b>0.00</b>	
Amount of Paid-up Share Capital :	<b>102565057.50</b>	<b>0.00</b>	<b>0.00</b>	

**RECEIPT**

Receipt No : ACR0000000904819A

Date/Time : 22/10/2004 11:56

Transaction No : C040479781

Agency : RCB - RCB

Application : BIZFILE PAYMENT SERVICE

Paid via : Deposit Service Account

EP Ref No :

**SINGAPORE AIRPORT TERMINAL SERVICES LIMITED  
20 AIRPORT BOULEVARD  
SATS INFLIGHT CATERING CENTRE 3  
SINGAPORE 819659**

---

<b>Sno Code/Description</b>	<b>Unit Price (S\$)</b>	<b>Qty</b>	<b>Amount</b>
1 Lodgment Of Return Of Allotment Of Share <b>COMPANY NAME :</b> 197201770G / SINGAPORE AIRPORT TERMINAL SERVICES LIMITED	10.00	1	10.00
<b>Total (S\$) :</b>			<b>10.00</b>

---

**Deposit Service Account No. : 030066**  
**Balance Amount in Deposit Account : \$ 155.00**

This is a computer-generated receipt. No signature is required.

Please print a copy of the receipt for your reference.

[HOME](#)[LOGOUT](#)



**LOCAL COMPANY TRANSACTIONS**[HOME](#)[LOGOUT](#)**Return of Allotment of Shares**[Submit](#)

Please fill in the following information. Fields marked \* must be completed.

Resolution/Declaration	Shares payable in cash	For a consideration other than cash	Share Capital/Allottees Particulars	List of Shareholders after the allotment	Summary of Capital
------------------------	---------------------------	---	---	---	-----------------------

**Record saved successfully.****Company Type**

Please click on appropriate button :

- company is listed on the securities exchange
- company is an unlisted public company
- company is a private company

**Power under Section 161 of the Companies Act \***

The directors have obtained  
the approval of the company in  Yes  
general meeting to issue  No  
shares.

**Resolution Made**

\* You are only required to fill in this section if the directors are not given the power under Section 161 of the Companies Act to issue shares.

Registration No. : **197201770G**Company Name : **SINGAPORE AIRPORT TERMINAL SERVICES LIMITED**Nature of Meeting : \*  ▼Place of Meeting : \*   
Date of Meeting: \*  (dd/mm/yyyy)Resolution Type : \*  ▼Description : \*  
(max 2000 characters) Attachment : \*  
(copy of resolution)**Note :**

Uploaded file name will be  
changed by suffixing time-  
stamp with the actual file  
name as

**filenameyyyyMMddmmsstt** [Browse...](#)

(Click 'Browse' to select file for attachment)

**Persons signing the resolution**

Please indicate the directors/ secretaries who signed the resolution :

- S0036442H / OW CHIN HOCK
- S0070715E / NG KEE CHOE
- S0234645A / CHEW CHOON SENG
- S1001765C / BARRY HENRY PATRICK DESKER
- S1069567H / TAN JIAK NGEE MICHAEL
- S1673157I / YIP WAI PING ANNABELLE
- S1852301I / HONG HAI @ HUANG HAI
- S2163476Z / CHENG WAI WING EDMUND
- S2580327B / RICHARD CHARLES HELFER

Please enter names of other corporate representatives who signed the resolution, if applicable :

**Declaration**

I, LIM HONG ENG SUSANNA, Professional body/service bureau, declare the information which has been submitted herein to be true to the best of my knowledge.

**Return of Allotment of Shares**

**Submit**

Please fill in the following information. Fields marked \* must be completed.

<u>Resolution / Declaration</u>	<u>Share payable in cash</u>	<u>For a consideration other than cash</u>	<u>Share Capital / Allottees Particulars</u>	<u>List of Shareholders after the Allotment</u>	<u>Summary of Capital</u>
---------------------------------	------------------------------	--	--	---	---------------------------

**Authorised Capital**

	<u>Amount</u>	<u>Nominal Value per Share</u>	<u>Currency</u>
Authorised Capital :	<b>200000000</b>	<b>.1</b>	<b>SINGAPORE DOLLAR ( 099 )</b>

Description of discrepancy :

**Return of Allotment of Shares (Payable in cash) \***

Applicable only if share is payable in cash

<u>Class of Shares :</u>	<u>Ordinary</u>	<u>Preference</u>	<u>Others</u>
Number of shares :	<input type="text" value="7800"/>	<input type="text"/>	<input type="text"/>
Amount paid or due and payable on each share			
paid :	<input type="text" value="0.10"/>	<input type="text"/>	<input type="text"/>
due and payable :	<input type="text" value="0"/>	<input type="text"/>	<input type="text"/>
Amount of premium paid or payable on each share :	<input type="text" value="1.14"/>	<input type="text"/>	<input type="text"/>

**Save**    **Delete Issued Share**    **Reset**    **Back**

**Return of Allotment of Shares**

Submit

Please fill in the following information. Fields marked \* must be completed.

Resolution / Declaration	Share payable in cash	For a consideration other than cash	Share Capital / Allottees Particulars	List of Shareholders after the allotment	Summary of Capital
-----------------------------	--------------------------	---	---	---	-----------------------

**Particulars of Allottee**

Please indicate whether the allottee is an Individual : \*

- Allottee is an Individual  
 Allottee is NOT an Individual

If Allottee is an Individual :

Shareholder Category : \* **Individual**Identification No. : \*  Retrieve DetailsIdentification Type : \* Name : \* Nationality : \* Mobile No : Occupation : Email Address : Address Type : \*  Local  
 Foreign

Local Address (\* if Address Type is Local Address)

Postal Code :  Retrieve AddressBlock/House No. : Street Name : Unit : #  - Building/Estate Name : 

Foreign Address (\* if Address Type is Foreign Address)

Address :   

If Allottee is NOT an Individual :

Shareholder Category : \*  Search

Registration No. : \* 198003912M Retrieve Details  
Name : **THE CENTRAL DEPOSITORY (PTE) LIMITED**

Address Type : **Local**

Local Address (\* if Address Type is Local Address)

Postal Code : **068804**

Block/House No. : **2**

Street Name : **SHENTON WAY**

Unit : # **19 - 00**

Building/Estate Name : **SGX CENTRE I**

Foreign Address (\* if Address Type is Foreign Address)

Address :

**Details of Shares Allotted** \* Please read instructions carefully before entering.

Note : If any share or shares is/are co-owned by 2 or more persons, please assign an alphabet e.g. A to denote the Group and enter the same in the box. Enter the same alphabet in the box for every allottee in the same group. Skip this box if share(s) are owned by only one person.

Group of Share that is co-owned:  
(Share Group)

If share(s) is/are co-owned, only one allottee is to enter details in (a), (b), (c), (d) and (e). Enter "0" (zero) for subsequent allottees in box (b) and leave blank for rest of the items.

a) Nominal Value per Share :

b) No. of shares allotted :

c) Class of shares allotted :

d) Currency :

e) Date of allotment :  (dd/mm/yyyy)

**Return of Allotment of Shares****Submit**

Please fill in the following information. Fields marked \* must be completed.

<b>Resolution / Declaration</b>	<b>Share payable in cash</b>	<b><u>For a consideration other than cash</u></b>	<b>Share Capital / Allottees Particulars</b>	<b>List of Shareholders after Allotment</b>	<b>Summary of Capital</b>
-------------------------------------	----------------------------------	---	--	---	-------------------------------

**List of Allottees and their particulars****Identification****No./Registration Name  
No.****Shareholder Category**

198003912M	THE CENTRAL DEPOSITORY (PTE) LIMITED	Company / Foreign Branch
------------	---	--------------------------

If No. of shareholders exceeds 50, total No. of issued shares held by the remaining shareholders are :

	<b>Ordinary</b>	<b>Preference</b>	<b>Others</b>
<b>No. of Shares</b>	<b>0</b>	<b>0</b>	<b>0</b>

**Return of Allotment of Shares****Submit**

Please fill in the following information. Fields marked \* must be completed.

<b>Resolution / Declaration</b>	<b>Share payable in cash</b>	<b>For a consideration other than cash</b>	<b>Share Capital / Allottees Particulars</b>	<b>List of Shareholders after the allotment</b>	<b>Summary of Capital</b>
<b>Share Capital (1)</b>					
Currency :	<b>SINGAPORE DOLLAR (099)</b>				
Nominal Value per Share :	<b>0.10</b>				
Amount of Authorised Share Capital :	<b>200000000.00</b>				
Class of Shares :	Ordinary	Preference	Others		
Amount of Issued Share Capital :	<b>102563757.50</b>	<b>0.00</b>	<b>0.00</b>		
Amount of Paid-up Share Capital :	<b>102563757.50</b>	<b>0.00</b>	<b>0.00</b>		

GST No. :M9-0008879-T

**RECEIPT**

Receipt No : ACR0000000904796A

Date/Time : 22/10/2004 11:51

Transaction  
No : C040479753

Agency : RCB - RCB

Application : BIZFILE PAYMENT SERVICE

Paid via : Deposit Service Account

EP Ref No :

**SINGAPORE AIRPORT TERMINAL SERVICES LIMITED  
20 AIRPORT BOULEVARD  
SATS INFLIGHT CATERING CENTRE 3  
SINGAPORE 819659**

<b>Sno Code/Description</b>	<b>Unit Price (S\$)</b>	<b>Qty</b>	<b>Amount</b>
1 Lodgment Of Return Of Allotment Of Share <b>COMPANY NAME :</b> 197201770G / SINGAPORE AIRPORT TERMINAL SERVICES LIMITED	10.00	1	10.00
<b>Total (S\$) :</b>			<b>10.00</b>

**Deposit Service Account No. : 030066**  
**Balance Amount in Deposit Account : \$ 165.00**

This is a computer-generated receipt. No signature is required.

Please print a copy of the receipt for your reference.

[HOME](#)[LOGOUT](#)



**LOCAL COMPANY TRANSACTIONS**[HOME](#)[LOGOUT](#)**Return of Allotment of Shares**[Submit](#)

Please fill in the following information. Fields marked \* must be completed.

Resolution/Declaration	Shares payable in cash	For a consideration other than cash	Share Capital/Allottees Particulars	List of Shareholders after the allotment	Summary of Capital
------------------------	---------------------------	---	---	---	-----------------------

**Record saved successfully.****Company Type**

Please click on appropriate button :

- company is listed on the securities exchange  
 company is an unlisted public company  
 company is a private company

**Power under Section 161 of the Companies Act \***

The directors have obtained the approval of the company in  Yes  No general meeting to issue shares.

**Resolution Made**

\* You are only required to fill in this section if the directors are not given the power under Section 161 of the Companies Act to issue shares.

Registration No. : **197201770G**Company Name : **SINGAPORE AIRPORT TERMINAL SERVICES LIMITED**Nature of Meeting : \* 

Place of Meeting : \*

Date of Meeting: \*

 (dd/mm/yyyy)

Resolution Type : \*

Description : \*  
(max 2000 characters)Attachment : \*  
(copy of resolution)

**Note :**  
Uploaded file name will be changed by suffixing time-stamp with the actual file name as

filenameyyyyMMddmmsstt

 [Browse...](#)

(Click 'Browse' to select file for attachment)

**Persons signing the resolution**

Please indicate the directors/ secretaries who signed the resolution :

- S0036442H / OW CHIN HOCK
- S0070715E / NG KEE CHOE
- S0234645A / CHEW CHOON SENG
- S1001765C / BARRY HENRY PATRICK DESKER
- S1069567H / TAN JIAK NGEE MICHAEL
- S1673157I / YIP WAI PING ANNABELLE
- S1852301I / HONG HAI @ HUANG HAI
- S2163476Z / CHENG WAI WING EDMUND
- S2580327B / RICHARD CHARLES HELFER

Please enter names of other corporate representatives who signed the resolution, if applicable :

**Declaration**

I, LIM HONG ENG SUSANNA, Professional body/service bureau, declare the information which has been submitted herein to be true to the best of my knowledge.

**Return of Allotment of Shares**

**Submit**

Please fill in the following information. Fields marked \* must be completed.

<u>Resolution / Declaration</u>	<u>Share payable in cash</u>	<u>For a consideration other than cash</u>	<u>Share Capital / Allottees Particulars</u>	<u>List of Shareholders after the Allotment</u>	<u>Summary of Capital</u>
---------------------------------	------------------------------	--	--	---	---------------------------

**Authorised Capital**

	<u>Amount</u>	<u>Nominal Value per Share</u>	<u>Currency</u>
Authorised Capital :	<b>200000000</b>	<b>.1</b>	<b>SINGAPORE DOLLAR ( 099 )</b>

Description of discrepancy :

**Return of Allotment of Shares (Payable in cash) \***

Applicable only if share is payable in cash

<u>Class of Shares :</u>	<u>Ordinary</u>	<u>Preference</u>	<u>Others</u>
Number of shares :	<input type="text" value="7800"/>	<input type="text"/>	<input type="text"/>
Amount paid or due and payable on each share			
paid :	<input type="text" value="0.10"/>	<input type="text"/>	<input type="text"/>
due and payable :	<input type="text" value="0"/>	<input type="text"/>	<input type="text"/>
Amount of premium paid or payable on each share :	<input type="text" value="1.70"/>	<input type="text"/>	<input type="text"/>

**Save**    **Delete Issued Share**    **Reset**    **Back**

**Return of Allotment of Shares**

Submit

Please fill in the following information. Fields marked \* must be completed.

<u>Resolution / Declaration</u>	<u>Share payable in cash</u>	<u>For a consideration other than cash</u>	<u>Share Capital / Allottees Particulars</u>	<u>List of Shareholders after the allotment</u>	<u>Summary of Capital</u>
-------------------------------------	----------------------------------	--	--	---	-------------------------------

**Particulars of Allottee**

Please indicate whether the allottee is an Individual : \*

- Allottee is an Individual  
 Allottee is NOT an Individual

If Allottee is an Individual :

Shareholder Category : \* **Individual**

Identification No. : \*

 Retrieve Details

Identification Type : \*

Name : \*

Nationality : \*

Mobile No :

Occupation :

Email Address :

Address Type : \*

- Local  
 Foreign

Local Address (\* if Address Type is Local Address)

Postal Code :

 Retrieve Address

Block/House No. :

Street Name :

Unit : #  - 

Building/Estate Name :

Foreign Address (\* if Address Type is Foreign Address)

Address :

If Allottee is NOT an Individual :

Shareholder Category : \*

 Search

Registration No. : \*

198003912M

Retrieve Details

Name : **THE CENTRAL DEPOSITORY (PTE) LIMITED**

Address Type : **Local**

Local Address (\* if Address Type is Local Address)

Postal Code : **068804**

Block/House No. : **2**

Street Name : **SHENTON WAY**

Unit : # **19 - 00**

Building/Estate Name : **SGX CENTRE I**

Foreign Address (\* if Address Type is Foreign Address)

Address :

**Details of Shares Allotted** \* Please read instructions carefully before entering.

Note : If any share or shares is/are co-owned by 2 or more persons, please assign an alphabet e.g. **A** to denote the Group and enter the same in the box. Enter the same alphabet in the box for every allottee in the same group. Skip this box if share(s) are owned by only one person.

Group of Share that is co-owned:  
(Share Group)

If share(s) is/are co-owned, only one allottee is to enter details in (a), (b), (c), (d) and (e). Enter "0" (zero) for subsequent allottees in box (b) and leave blank for rest of the items.

a) Nominal Value per Share :

b) No. of shares allotted :

c) Class of shares allotted :

d) Currency :

e) Date of allotment :  (dd/mm/yyyy)

**Return of Allotment of Shares**[Submit](#)

Please fill in the following information. Fields marked \* must be completed.

<b>Resolution / Declaration</b>	<b>Share payable in cash</b>	<b><u>For a consideration other than cash</u></b>	<b>Share Capital / Allottees Particulars</b>	<b>List of Shareholders after Allotment</b>	<b>Summary of Capital</b>
-------------------------------------	----------------------------------	---	--	---	-------------------------------

**List of Allottees and their particulars****Identification****No./Registration Name  
No.****Shareholder Category**

198003912M	THE CENTRAL DEPOSITORY (PTE) LIMITED	Company / Foreign Branch
------------	---	--------------------------

If No. of shareholders exceeds 50, total No. of issued shares held by the remaining shareholders are :

<b>No. of Shares</b>	<b>Ordinary</b>	<b>Preference</b>	<b>Others</b>
	0	0	0

**Return of Allotment of Shares****Submit**

Please fill in the following information. Fields marked \* must be completed.

<u>Resolution / Declaration</u>	<u>Share payable in cash</u>	<u>For a consideration other than cash</u>	<u>Share Capital / Allottees Particulars</u>	<u>List of Shareholders after the allotment</u>	<u>Summary of Capital</u>
<b>Share Capital (1)</b>					
Currency :	<b>SINGAPORE DOLLAR (099)</b>				
Nominal Value per Share :	<b>0.10</b>				
Amount of Authorised Share Capital :	<b>200000000.00</b>				
Class of Shares :	Ordinary	Preference	Others		
Amount of Issued Share Capital :	<b>102562977.50</b>	<b>0.00</b>	<b>0.00</b>		
Amount of Paid-up Share Capital :	<b>102562977.50</b>	<b>0.00</b>	<b>0.00</b>		



GST No. :M9-0008879-T

**RECEIPT**

Receipt No : ACR0000000904531A  
Transaction No : C040479464  
Agency : RCB - RCB  
Application : BIZFILE PAYMENT SERVICE  
Paid via : Deposit Service Account  
EP Ref No :

Date/Time : 22/10/2004 10:39

**SINGAPORE AIRPORT TERMINAL SERVICES LIMITED**  
**20 AIRPORT BOULEVARD**  
**SATS INFLIGHT CATERING CENTRE 3**  
**SINGAPORE 819659**

---

<b>Sno Code/Description</b>	<b>Unit Price (\$)</b>	<b>Qty</b>	<b>Amount</b>
1 Lodgment Of Return Of Allotment Of Share	10.00	1	10.00
<b>COMPANY NAME :</b> 197201770G / SINGAPORE AIRPORT TERMINAL SERVICES LIMITED			
<b>Total (\$):</b>			<b>10.00</b>

---

**Deposit Service Account No. : 030066**  
**Balance Amount in Deposit Account : \$ 175.00**

This is a computer-generated receipt. No signature is required.

Please print a copy of the receipt for your reference.

[HOME](#)[LOGOUT](#)



**LOCAL COMPANY TRANSACTIONS**

HOME

LOGOUT

**Return of Allotment of Shares**

Submit

Please fill in the following information. Fields marked \* must be completed.

Resolution/Declaration	Shares payable in cash	For a consideration other than cash	Share Capital/Allottees Particulars	List of Shareholders after the allotment	Summary of Capital
------------------------	---------------------------	---	---	---	-----------------------

**Record saved successfully.****Company Type**

Please click on appropriate button :

- company is listed on the securities exchange  
 company is an unlisted public company  
 company is a private company

**Power under Section 161 of the Companies Act \***

The directors have obtained the approval of the company in general meeting to issue shares.

Yes  
 No

**Resolution Made**

\* You are only required to fill in this section if the directors are not given the power under Section 161 of the Companies Act to issue shares.

Registration No. : **197201770G**Company Name : **SINGAPORE AIRPORT TERMINAL SERVICES LIMITED**

Nature of Meeting : \* Directors

Place of Meeting : \*

Date of Meeting : \* (dd/mm/yyyy)

Resolution Type : \* Director's

Description : \*  
(max 2000 characters)Attachment : \*  
(copy of resolution)**Note :**

Uploaded file name will be changed by suffixing time-stamp with the actual file name as

filenameyyyyMMddmmsstt

Browse...

(Click 'Browse' to select file for attachment)

**Persons signing the resolution**

Please indicate the directors/ secretaries who signed the resolution :

- S0036442H / OW CHIN HOCK
- S0070715E / NG KEE CHOE
- S0234645A / CHEW CHOON SENG
- S1001765C / BARRY HENRY PATRICK DESKER
- S1069567H / TAN JIAK NGEE MICHAEL
- S1673157I / YIP WAI PING ANNABELLE
- S1852301I / HONG HAI @ HUANG HAI
- S2163476Z / CHENG WAI WING EDMUND
- S2580327B / RICHARD CHARLES HELFER

Please enter names of other corporate representatives who signed the resolution, if applicable :

**Declaration**

I, LIM HONG ENG SUSANNA, Professional body/service bureau, declare the information which has been submitted herein to be true to the best of my knowledge.

**Return of Allotment of Shares**

Please fill in the following information. Fields marked \* must be completed.

<b>Resolution / Declaration</b>	<b>Share payable in cash</b>	<b>For a consideration other than cash</b>	<b>Share Capital / Allottees Particulars</b>	<b>List of Shareholders after the Allotment</b>	<b>Summary of Capital</b>
-------------------------------------	----------------------------------	--	--	---	-------------------------------

**Authorised Capital**

	<b>Amount</b>	<b>Nominal Value per Share</b>	<b>Currency</b>
Authorised Capital :	<b>20000000</b>	<b>.1</b>	<b>SINGAPORE DOLLAR ( 099 )</b>

Description of discrepancy :

**Return of Allotment of Shares (Payable in cash) \***

Applicable only if share is payable in cash

<b>Class of Shares :</b>	<b>Ordinary</b>	<b>Preference</b>	<b>Others</b>
Number of shares :	<input type="text" value="10400"/>	<input type="text"/>	<input type="text"/>
Amount paid or due and payable on each share			
paid :	<input type="text" value="0.10"/>	<input type="text"/>	<input type="text"/>
due and payable :	<input type="text" value="0"/>	<input type="text"/>	<input type="text"/>
Amount of premium paid or payable on each share :	<input type="text" value="1.50"/>	<input type="text"/>	<input type="text"/>

**Return of Allotment of Shares****Submit**

Please fill in the following information. Fields marked \* must be completed.

<u>Resolution / Declaration</u>	<u>Share payable in cash</u>	<u>For a consideration other than cash</u>	<u>Share Capital / Allottees Particulars</u>	<u>List of Shareholders after the allotment</u>	<u>Summary of Capital</u>
-------------------------------------	----------------------------------	--	--	---	-------------------------------

**Particulars of Allottee**

Please indicate whether the allottee is an Individual : \*

- Allottee is an Individual  
 Allottee is NOT an Individual

**If Allottee is an Individual :**Shareholder Category : \* **Individual**Identification No. : \*  **Retrieve Details**Identification Type : \*  ▼Name : \* Nationality : \*  ▼Mobile No : Occupation : Email Address : Address Type : \*  
 Local  
 Foreign

Local Address (\* if Address Type is Local Address)

Postal Code :  **Retrieve Address**Block/House No. :  ▼Street Name : Unit : #  - Building/Estate Name : 

Foreign Address (\* if Address Type is Foreign Address)

Address : **If Allottee is NOT an Individual :**Shareholder Category : \*  ▼ **Search**

Name : THE CENTRAL DEPOSITORY (PTE) LIMITED

Address Type : Local

Local Address (\* if Address Type is Local Address)

Postal Code : 068804

Block/House No. : 2

Street Name : SHENTON WAY

Unit : # 19 - 00

Building/Estate Name : SGX CENTRE I

Foreign Address (\* if Address Type is Foreign Address)

Address :

**Details of Shares Allotted** \* Please read instructions carefully before entering.

Note : If any share or shares is/are co-owned by 2 or more persons, please assign an alphabet e.g. A to denote the Group and enter the same in the box. Enter the same alphabet in the box for every allottee in the same group. Skip this box if share(s) are owned by only one person.

Group of Share that is co-owned:   
(Share Group)

If share(s) is/are co-owned, only one allottee is to enter details in (a), (b), (c), (d) and (e). Enter "0" (zero) for subsequent allottees in box (b) and leave blank for rest of the items.

a) Nominal Value per Share :

b) No. of shares allotted :

c) Class of shares allotted :

d) Currency :

e) Date of allotment :  (dd/mm/yyyy)

**Return of Allotment of Shares****Submit**

Please fill in the following information. Fields marked \* must be completed.

<b>Resolution / Declaration</b>	<b>Share payable in cash</b>	<b>For a consideration other than cash</b>	<b>Share Capital / Allottees Particulars</b>	<b>List of Shareholders after Allotment</b>	<b>Summary of Capital</b>
-------------------------------------	----------------------------------	--	--	---	-------------------------------

**List of Allottees and their particulars****Identification****No./Registration Name  
No.****Shareholder Category**

198003912M	THE CENTRAL DEPOSITORY (PTE) LIMITED	Company / Foreign Branch
------------	---	--------------------------

If No. of shareholders exceeds 50, total No. of issued shares held by the remaining shareholders are :

<b>No. of Shares</b>	<b>Ordinary</b>	<b>Preference</b>	<b>Others</b>
	0	0	0

**Return of Allotment of Shares****Submit**

Please fill in the following information. Fields marked \* must be completed.

<u>Resolution / Declaration</u>	<u>Share payable in cash</u>	<u>For a consideration other than cash</u>	<u>Share Capital / Allottees Particulars</u>	<u>List of Shareholders after the allotment</u>	<u>Summary of Capital</u>
<b>Share Capital (1)</b>					
Currency :	<b>SINGAPORE DOLLAR (099)</b>				
Nominal Value per Share :	<b>0.10</b>				
Amount of Authorised Share Capital :	<b>200000000.00</b>				
Class of Shares :	Ordinary	Preference	Others		
Amount of Issued Share Capital :	<b>102562197.50</b>	<b>0.00</b>	<b>0.00</b>		
Amount of Paid-up Share Capital :	<b>102562197.50</b>	<b>0.00</b>	<b>0.00</b>		

GST No. :M9-0008879-T

**RECEIPT**

Receipt No : ACR0000000904512A

Date/Time : 22/10/2004 10:33

Transaction  
No : C040479436

Agency : RCB - RCB

Application : BIZFILE PAYMENT SERVICE

Paid via : Deposit Service Account

EP Ref No :

**SINGAPORE AIRPORT TERMINAL SERVICES LIMITED**  
**20 AIRPORT BOULEVARD**  
**SATS INFLIGHT CATERING CENTRE 3**  
**SINGAPORE 819659**

<b>Sno Code/Description</b>	<b>Unit Price (S\$)</b>	<b>Qty</b>	<b>Amount</b>
1 Lodgment Of Return Of Allotment Of Share <b>COMPANY NAME :</b> 197201770G / SINGAPORE AIRPORT TERMINAL SERVICES LIMITED	10.00	1	10.00
<b>Total (S\$) :</b>			<b>10.00</b>

**Deposit Service Account No. : 030066**  
**Balance Amount in Deposit Account : \$ 185.00**

This is a computer-generated receipt. No signature is required.

Please print a copy of the receipt for your reference.

[HOME](#)[LOGOUT](#)



**Return of Allotment of Shares****Submit**

Please fill in the following information. Fields marked \* must be completed.

Resolution/Declaration	Shares payable in cash	For a consideration other than cash	Share Capital/Allottees Particulars	List of Shareholders after the allotment	Summary of Capital
------------------------	------------------------	-------------------------------------	-------------------------------------	--	--------------------

**Record saved successfully.****Company Type**

Please click on appropriate button :

- company is listed on the securities exchange ✓
- company is an unlisted public company
- company is a private company

**Power under Section 161 of the Companies Act \***

The directors have obtained the approval of the company in general meeting to issue shares.

Yes ✓

No

**Resolution Made**

\* You are only required to fill in this section if the directors are not given the power under Section 161 of the Companies Act to issue shares.

Registration No. : **197201770G**

Company Name : **SINGAPORE AIRPORT TERMINAL SERVICES LIMITED**

Nature of Meeting : \*

Place of Meeting : \*

Date of Meeting: \*  (dd/mm/yyyy)

Resolution Type : \*

Description : \*

(max 2000 characters)

Attachment : \*  
(copy of resolution)

**Note :**  
 Uploaded file name will be changed by suffixing time-stamp with the actual file name as  
**filenameyyyyMMddmmsstt**

**Browse...**

(Click 'Browse' to select file for attachment)

**Persons signing the resolution**

Please indicate the directors/ secretaries who signed the resolution :

- S0036442H / OW CHIN HOCK
- S0070715E / NG KEE CHOE
- S0234645A / CHEW CHOON SENG
- S1001765C / BARRY HENRY PATRICK DESKER
- S1069567H / TAN JIAK NGEE MICHAEL
- S1673157I / YIP WAI PING ANNABELLE
- S1852301I / HONG HAI @ HUANG HAI
- S2163476Z / CHENG WAI WING EDMUND
- S2580327B / RICHARD CHARLES HELFER

Please enter names of other corporate representatives who signed the resolution, if applicable :

**Declaration**

I, LIM HONG ENG SUSANNA, Professional body/service bureau, declare the information which has been submitted herein to be true to the best of my knowledge.

**Return of Allotment of Shares****Submit**

Please fill in the following information. Fields marked \* must be completed.

<u>Resolution / Declaration</u>	<u>Share payable in cash</u>	<u>For a consideration other than cash</u>	<u>Share Capital / Allottees Particulars</u>	<u>List of Shareholders after the Allotment</u>	<u>Summary of Capital</u>
---------------------------------	------------------------------	--	--	---	---------------------------

**Authorised Capital**

	<u>Amount</u>	<u>Nominal Value per Share</u>	<u>Currency</u>
Authorised Capital :	<b>20000000</b>	<b>.1</b>	<b>SINGAPORE DOLLAR ( 099 )</b>

Description of discrepancy :

**Return of Allotment of Shares (Payable in cash) \***

Applicable only if share is payable in cash

<u>Class of Shares :</u>	<u>Ordinary</u>	<u>Preference</u>	<u>Others</u>
Number of shares :	<input type="text" value="5200"/>	<input type="text"/>	<input type="text"/>
Amount paid or due and payable on each share			
paid :	<input type="text" value="0.10"/>	<input type="text"/>	<input type="text"/>
due and payable :	<input type="text" value="0"/>	<input type="text"/>	<input type="text"/>
Amount of premium paid or payable on each share :	<input type="text" value="1.14"/>	<input type="text"/>	<input type="text"/>

**Save****Delete Issued Share****Reset****Back**

**Return of Allotment of Shares****Submit**

Please fill in the following information. Fields marked \* must be completed.

<u>Resolution / Declaration</u>	<u>Share payable in cash</u>	<u>For a consideration other than cash</u>	<u>Share Capital / Allottees Particulars</u>	<u>List of Shareholders after the allotment</u>	<u>Summary of Capital</u>
---------------------------------	------------------------------	--	--	---	---------------------------

**Particulars of Allottee****Please indicate whether the allottee is an Individual : \***

- Allottee is an Individual
- Allottee is NOT an Individual

**If Allottee is an Individual :**Shareholder Category : \* **Individual**Identification No. : \*  **Retrieve Details**Identification Type : \*  Name : \* Nationality : \*  Mobile No : Occupation : Email Address : Address Type : \*  Local  Foreign

Local Address (\* if Address Type is Local Address)

Postal Code :  **Retrieve Address**Block/House No. :  

Street Name :

Unit : #  - 

Building/Estate Name :

Foreign Address (\* if Address Type is Foreign Address)

Address : **If Allottee is NOT an Individual :**Shareholder Category : \*   **Search**

Registration No. : \*

198003912M

Retrieve Details

Name :

**THE CENTRAL DEPOSITORY (PTE) LIMITED**

Address Type :

**Local**

Local Address (\* if Address Type is Local Address)

Postal Code : **068804**

Block/House No. : **2**

Street Name : **SHENTON WAY**

Unit : # **19 - 00**

Building/Estate Name : **SGX CENTRE I**

Foreign Address (\* if Address Type is Foreign Address)

Address :

**Details of Shares Allotted** \* Please read instructions carefully before entering.

Note : If any share or shares is/are co-owned by 2 or more persons, please assign an alphabet e.g. A to denote the Group and enter the same in the box. Enter the same alphabet in the box for every allottee in the same group. Skip this box if share(s) are owned by only one person.

Group of Share that is co-owned:  
(Share Group)

If share(s) is/are co-owned, only one allottee is to enter details in (a), (b), (c), (d) and (e). Enter "0" (zero) for subsequent allottees in box (b) and leave blank for rest of the items.

a) Nominal Value per Share :

0.10

b) No. of shares allotted :

5200

c) Class of shares allotted :

Ordinary

d) Currency :

SINGAPORE DOLLAR (099)

e) Date of allotment :

18/10/2004

(dd/mm/yyyy)

Save

Reset

Back

**Return of Allotment of Shares****Submit**

Please fill in the following information. Fields marked \* must be completed.

<b>Resolution / Declaration</b>	<b>Share payable in cash</b>	<b>For a consideration other than cash</b>	<b>Share Capital / Allottees Particulars</b>	<b>List of Shareholders after Allotment</b>	<b>Summary of Capital</b>
-------------------------------------	----------------------------------	--	--	---	-------------------------------

**List of Allottees and their particulars****Identification****No./Registration Name  
No.****Shareholder Category**

198003912M	THE CENTRAL DEPOSITORY (PTE) LIMITED	Company / Foreign Branch
------------	---	--------------------------

If No. of shareholders exceeds 50, total No. of issued shares held by the remaining shareholders are :

<b>No. of Shares</b>	<b>Ordinary</b>	<b>Preference</b>	<b>Others</b>
	0	0	0

**Return of Allotment of Shares****Submit**

Please fill in the following information. Fields marked \* must be completed.

<u>Resolution / Declaration</u>	<u>Share payable in cash</u>	<u>For a consideration other than cash</u>	<u>Share Capital / Allottees Particulars</u>	<u>List of Shareholders after the allotment</u>	<u>Summary of Capital</u>
<b>Share Capital (1)</b>					
Currency :	<b>SINGAPORE DOLLAR (099)</b>				
Nominal Value per Share :	<b>0.10</b>				
Amount of Authorised Share Capital :	<b>200000000.00</b>				
Class of Shares :	Ordinary	Preference	Others		
Amount of Issued Share Capital :	<b>102561157.50</b>	<b>0.00</b>	<b>0.00</b>		
Amount of Paid-up Share Capital :	<b>102561157.50</b>	<b>0.00</b>	<b>0.00</b>		

GST No. :M9-0008879-T

**RECEIPT**

Receipt No : ACR0000000904487A

Date/Time : 22/10/2004 10:26

Transaction  
No : C040479405

Agency : RCB - RCB

Application : BIZFILE PAYMENT SERVICE

Paid via : Deposit Service Account

EP Ref No :

**SINGAPORE AIRPORT TERMINAL SERVICES LIMITED  
20 AIRPORT BOULEVARD  
SATS INFLIGHT CATERING CENTRE 3  
SINGAPORE 819659**

<b>Sno Code/Description</b>	<b>Unit Price (S\$)</b>	<b>Qty</b>	<b>Amount</b>
1 Lodgment Of Return Of Allotment Of Share <b>COMPANY NAME :</b> 197201770G / SINGAPORE AIRPORT TERMINAL SERVICES LIMITED	10.00	1	10.00
<b>Total (S\$) :</b>			<b>10.00</b>

**Deposit Service Account No. : 030066**  
**Balance Amount in Deposit Account : \$ 195.00**

This is a computer-generated receipt. No signature is required.

Please print a copy of the receipt for your reference.

[HOME](#)[LOGOUT](#)



**Return of Allotment of Shares**

Submit

Please fill in the following information. Fields marked \* must be completed.

Resolution/Declaration	Shares payable in cash	For a consideration other than cash	Share Capital/Allottees Particulars	List of Shareholders after the allotment	Summary of Capital
------------------------	---------------------------	---	---	---	-----------------------

Record saved successfully.

**Company Type**

Please click on appropriate button :

- company is listed on the securities exchange  
 company is an unlisted public company  
 company is a private company

**Power under Section 161 of the Companies Act \***

The directors have obtained the approval of the company in  Yes  
 general meeting to issue  No shares.

**Resolution Made**

\* You are only required to fill in this section if the directors are not given the power under Section 161 of the Companies Act to issue shares.

Registration No. : **197201770G**Company Name : **SINGAPORE AIRPORT TERMINAL SERVICES LIMITED**

Nature of Meeting : \* Directors

Place of Meeting : \*

Date of Meeting : \* (dd/mm/yyyy)

Resolution Type : \* Director's

Description : \*  
(max 2000 characters)Attachment : \*  
(copy of resolution)**Note :**

Uploaded file name will be changed by suffixing time-stamp with the actual file name as

filenameyyyyMMddmmsstt

Browse...

(Click 'Browse' to select file for attachment)

**Persons signing the resolution**

Please indicate the directors/ secretaries who signed the resolution :

- S0036442H / OW CHIN HOCK
- S0070715E / NG KEE CHOE
- S0234645A / CHEW CHOON SENG
- S1001765C / BARRY HENRY PATRICK DESKER
- S1069567H / TAN JIAK NGEE MICHAEL
- S1673157I / YIP WAI PING ANNABELLE
- S1852301I / HONG HAI @ HUANG HAI
- S2163476Z / CHENG WAI WING EDMUND
- S2580327B / RICHARD CHARLES HELFER

Please enter names of other corporate representatives who signed the resolution, if applicable :

**Declaration**

I, LIM HONG ENG SUSANNA, Professional body/service bureau, declare the information which has been submitted herein to be true to the best of my knowledge.

**Return of Allotment of Shares****Submit**

Please fill in the following information. Fields marked \* must be completed.

<b>Resolution / Declaration</b>	<b>Share payable in cash</b>	<b>For a consideration other than cash</b>	<b>Share Capital / Allottees Particulars</b>	<b>List of Shareholders after the Allotment</b>	<b>Summary of Capital</b>
---------------------------------	------------------------------	--	--	---	---------------------------

**Authorised Capital**

	<b>Amount</b>	<b>Nominal Value per Share</b>	<b>Currency</b>
Authorised Capital :	<b>200000000</b>	<b>.1</b>	<b>SINGAPORE DOLLAR ( 099 )</b>

Description of discrepancy :

**Return of Allotment of Shares (Payable in cash) \***

Applicable only if share is payable in cash

<b>Class of Shares :</b>	<b>Ordinary</b>	<b>Preference</b>	<b>Others</b>
Number of shares :	5200 /		
Amount paid or due and payable on each share			
paid :	0.10 /		
due and payable :	0 /		
Amount of premium paid or payable on each share :	1.70 /		

**Save** **Delete Issued Share** **Reset** **Back**

**Return of Allotment of Shares**

Submit

Please fill in the following information. Fields marked \* must be completed.

Resolution / Declaration	Share payable in cash	For a consideration other than cash	Share Capital / Allottees Particulars	List of Shareholders after the allotment	Summary of Capital
-----------------------------	--------------------------	---	---	---	-----------------------

**Particulars of Allottee**

Please indicate whether the allottee is an Individual : \*

- Allottee is an Individual  
 Allottee is NOT an Individual

If Allottee is an Individual :

Shareholder Category : \* **Individual**

Identification No. : \*

Retrieve Details

Identification Type : \*

NRIC 

Name : \*

Nationality : \*

Mobile No. :

Occupation :

Email Address :

Address Type : \*

- Local  
 Foreign

Local Address (\* if Address Type is Local Address)

Postal Code :

Retrieve Address

Block/House No. :

Street Name :

Unit : #

 - 

Building/Estate Name :

Foreign Address (\* if Address Type is Foreign Address)

Address :

If Allottee is NOT an Individual :

Shareholder Category : \*

Company / Foreign Branch 

Search

Registration No.: \*

198003912M

Retrieve Details

Name :

THE CENTRAL DEPOSITORY (PTE) LIMITED

Address Type :

Local

Local Address (\* if Address Type is Local Address)

Postal Code : 068804

Block/House No. : 2

Street Name : SHENTON WAY

Unit : # 19 - 00

Building/Estate Name : SGX CENTRE I

Foreign Address (\* if Address Type is Foreign Address)

Address :

**Details of Shares Allotted** \* Please read instructions carefully before entering.

Note : If any share or shares is/are co-owned by 2 or more persons, please assign an alphabet e.g. A to denote the Group and enter the same in the box. Enter the same alphabet in the box for every allottee in the same group. Skip this box if share(s) are owned by only one person.

Group of Share that is co-owned:  
(Share Group)

If share(s) is/are co-owned, only one allottee is to enter details in (a), (b), (c), (d) and (e). Enter "0" (zero) for subsequent allottees in box (b) and leave blank for rest of the items.

a) Nominal Value per Share :

b) No. of shares allotted :

c) Class of shares allotted :

d) Currency :

e) Date of allotment :

 (dd/mm/yyyy)

Save

Reset

Back

**Return of Allotment of Shares****Submit**

Please fill in the following information. Fields marked \* must be completed.

<b>Resolution / Declaration</b>	<b>Share payable in cash</b>	<b>For a consideration other than cash</b>	<b>Share Capital / Allottees Particulars</b>	<b>List of Shareholders after Allotment</b>	<b>Summary of Capital</b>
-------------------------------------	----------------------------------	--	--	---	-------------------------------

**List of Allottees and their particulars****Identification****No./ Registration Name  
No.****Shareholder Category**

198003912M	THE CENTRAL DEPOSITORY (PTE) LIMITED	Company / Foreign Branch
------------	---	--------------------------

If No. of shareholders exceeds 50, total No. of issued shares held by the remaining shareholders are :

<b>No. of Shares</b>	<b>Ordinary</b>	<b>Preference</b>	<b>Others</b>
	0	0	0

**Return of Allotment of Shares****Submit**

Please fill in the following information. Fields marked \* must be completed.

<u>Resolution / Declaration</u>	<u>Share payable in cash</u>	<u>For a consideration other than cash</u>	<u>Share Capital / Allottees Particulars</u>	<u>List of Shareholders after the allotment</u>	<u>Summary of Capital</u>
<b>Share Capital (1)</b>					
Currency :	<b>SINGAPORE DOLLAR (099)</b>				
Nominal Value per Share :	<b>0.10</b>				
Amount of Authorised Share Capital :	<b>200000000.00</b>				
Class of Shares :	Ordinary	Preference	Others		
Amount of Issued Share Capital :	<b>102560637.50</b>	<b>0.00</b>	<b>0.00</b>		
Amount of Paid-up Share Capital :	<b>102560637.50</b>	<b>0.00</b>	<b>0.00</b>		

**RECEIPT**

Receipt No : ACR0000000902633A

Date/Time : 21/10/2004 10:39

Transaction No : C040477408

Agency : RCB - RCB

Application : BIZFILE PAYMENT SERVICE

Paid via : Deposit Service Account

EP Ref No :

**SINGAPORE AIRPORT TERMINAL SERVICES LIMITED**  
**20 AIRPORT BOULEVARD**  
**SATS INFLIGHT CATERING CENTRE 3**  
**SINGAPORE 819659**

<b>Sno Code/Description</b>	<b>Unit Price (S\$)</b>	<b>Qty</b>	<b>Amount</b>
1 Lodgment Of Return Of Allotment Of Share	10.00	1	10.00
<b>COMPANY NAME :</b> 197201770G / SINGAPORE AIRPORT TERMINAL SERVICES LIMITED			
<b>Total (S\$) :</b>			<b>10.00</b>

**Deposit Service Account No. : 030066**  
**Balance Amount in Deposit Account : \$ 205.00**

This is a computer-generated receipt. No signature is required.

Please print a copy of the receipt for your reference.

[HOME](#)[LOGOUT](#)



**LOCAL COMPANY TRANSACTIONS****Return of Allotment of Shares****Submit**

Please fill in the following information. Fields marked \* must be completed.

Resolution/Declaration	Shares payable in cash	For a consideration other than cash	Share Capital/Allottees Particulars	List of Shareholders after the allotment	Summary of Capital
------------------------	---------------------------	---	---	---	-----------------------

**Record saved successfully.****Company Type**

Please click on appropriate button :

- company is listed on the securities exchange
- company is an unlisted public company
- company is a private company

**Power under Section 161 of the Companies Act \***

The directors have obtained  
the approval of the company in  Yes  
general meeting to issue  No  
shares.

**Resolution Made**

\* You are only required to fill in this section if the directors are not given the power under Section 161 of the Companies Act to issue shares.

Registration No. : **197201770G**Company Name : **SINGAPORE AIRPORT TERMINAL SERVICES LIMITED**Nature of Meeting : \* Place of Meeting : \* Date of Meeting : \*  (dd/mm/yyyy)Resolution Type : \* Description : \*   
(max 2000 characters)Attachment : \*  
(copy of resolution)**Note :**  **Browse...**

Uploaded file name will be  
changed by suffixing time-  
stamp with the actual file  
name as

(Click 'Browse' to select file for attachment)

**filenameyyyyMMddmmsstt**

**Persons signing the resolution**

Please indicate the directors/ secretaries who signed the resolution :

- S0036442H / OW CHIN HOCK
- S0070715E / NG KEE CHOE
- S0234645A / CHEW CHOON SENG
- S1001765C / BARRY HENRY PATRICK DESKER
- S1069567H / TAN JIAK NGEE MICHAEL
- S1673157I / YIP WAI PING ANNABELLE
- S1852301I / HONG HAI @ HUANG HAI
- S2163476Z / CHENG WAI WING EDMUND
- S2580327B / RICHARD CHARLES HELFER

Please enter names of other corporate representatives who signed the resolution, if applicable :

**Declaration**

I, LIM HONG ENG SUSANNA, Professional body/service bureau, declare the information which has been submitted herein to be true to the best of my knowledge.

**Return of Allotment of Shares**[Submit](#)

Please fill in the following information. Fields marked \* must be completed.

<u>Resolution / Declaration</u>	<u>Share payable in cash</u>	<u>For a consideration other than cash</u>	<u>Share Capital / Allottees Particulars</u>	<u>List of Shareholders after the Allotment</u>	<u>Summary of Capital</u>
---------------------------------	------------------------------	--	--	---	---------------------------

**Authorised Capital**

	Amount	Nominal Value per Share	Currency
Authorised Capital :	<b>200000000</b>	<b>.1</b>	<b>SINGAPORE DOLLAR ( 099 )</b>

Description of discrepancy :

**Return of Allotment of Shares (Payable in cash) \***

Applicable only if share is payable in cash

Class of Shares :	Ordinary	Preference	Others
Number of shares :	<input type="text" value="67600"/>	<input type="text"/>	<input type="text"/>
Amount paid or due and payable on each share			
paid :	<input type="text" value="0.10"/>	<input type="text"/>	<input type="text"/>
due and payable :	<input type="text" value="0"/>	<input type="text"/>	<input type="text"/>
Amount of premium paid or payable on each share :	<input type="text" value="1.50"/>	<input type="text"/>	<input type="text"/>

[Save](#)
[Delete Issued Share](#)
[Reset](#)
[Back](#)

**Return of Allotment of Shares****Submit**

Please fill in the following information. Fields marked \* must be completed.

<u>Resolution / Declaration</u>	<u>Share payable in cash</u>	<u>For a consideration other than cash</u>	<u>Share Capital / Allottees Particulars</u>	<u>List of Shareholders after the allotment</u>	<u>Summary of Capital</u>
---------------------------------	------------------------------	--	--	---	---------------------------

**Particulars of Allottee****Please indicate whether the allottee is an Individual : \***

- Allottee is an Individual
- Allottee is NOT an Individual

**If Allottee is an Individual :**Shareholder Category : \* **Individual**Identification No. : \*  **Retrieve Details**Identification Type : \* Name : \* Nationality : \* Mobile No : Occupation : Email Address : Address Type : \*  Local  Foreign

Local Address (\* if Address Type is Local Address)

Postal Code :  **Retrieve Address**Block/House No. : Street Name : Unit : #  - Building/Estate Name : 

Foreign Address (\* if Address Type is Foreign Address)

Address :   
**If Allottee is NOT an Individual :**Shareholder Category : \*  **Search**

Registration No. : **THE CENTRAL DEPOSITORY (PTE) LIMITED**

Address Type : **Local**

Local Address (\* if Address Type is Local Address)

Postal Code : **068804**

Block/House No. : **2**

Street Name : **SHENTON WAY**

Unit : # **19 - 00**

Building/Estate Name : **SGX CENTRE I**

Foreign Address (\* if Address Type is Foreign Address)

Address :

**Details of Shares Allotted** \* Please read instructions carefully before entering.

Note : If any share or shares is/are co-owned by 2 or more persons, please assign an alphabet e.g. A to denote the Group and enter the same in the box. Enter the same alphabet in the box for every allottee in the same group. Skip this box if share(s) are owned by only one person.

Group of Share that is co-owned:  
(Share Group)

If share(s) is/are co-owned, only one allottee is to enter details in (a), (b), (c), (d) and (e). Enter "0" (zero) for subsequent allottees in box (b) and leave blank for rest of the items.

- a) Nominal Value per Share :
- b) No. of shares allotted :
- c) Class of shares allotted :
- d) Currency :
- e) Date of allotment :  (dd/mm/yyyy)

**Return of Allotment of Shares****Submit**

Please fill in the following information. Fields marked \* must be completed.

<b>Resolution / Declaration</b>	<b>Share payable in cash</b>	<b>For a consideration other than cash</b>	<b>Share Capital / Allottees Particulars</b>	<b>List of Shareholders after Allotment</b>	<b>Summary of Capital</b>
-------------------------------------	----------------------------------	--	--	---	-------------------------------

**List of Allottees and their particulars****Identification****No./Registration Name  
No.****Shareholder Category**

198003912M	THE CENTRAL DEPOSITORY (PTE) LIMITED	Company / Foreign Branch
------------	---	--------------------------

If No. of shareholders exceeds 50, total No. of issued shares held by the remaining shareholders are :

<b>No. of Shares</b>	<b>Ordinary</b>	<b>Preference</b>	<b>Others</b>
	0	0	0

## Return of Allotment of Shares

Submit

Please fill in the following information. Fields marked \* must be completed.

<u>Resolution / Declaration</u>	<u>Share payable in cash</u>	<u>For a consideration other than cash</u>	<u>Share Capital / Allottees Particulars</u>	<u>List of Shareholders after the allotment</u>	<u>Summary of Capital</u>
<b>Share Capital (1)</b>					
Currency :	<b>SINGAPORE DOLLAR (099)</b>				
Nominal Value per Share :	<b>0.10</b>				
Amount of Authorised Share Capital :	<b>200000000.00</b>				
Class of Shares :	Ordinary	Preference	Others		
Amount of Issued Share Capital :	<b>102560117.50</b>	<b>0.00</b>	<b>0.00</b>		
Amount of Paid-up Share Capital :	<b>102560117.50</b>	<b>0.00</b>	<b>0.00</b>		

**RECEIPT**

Receipt No : ACR0000000902610A  
Transaction No : C040477383  
Agency : RCB - RCB  
Application : BIZFILE PAYMENT SERVICE  
Paid via : Deposit Service Account  
EP Ref No :

Date/Time : 21/10/2004 10:33

**SINGAPORE AIRPORT TERMINAL SERVICES LIMITED**  
**20 AIRPORT BOULEVARD**  
**SATS INFLIGHT CATERING CENTRE 3**  
**SINGAPORE 819659**

---

<b>Sno Code/Description</b>	<b>Unit Price (S\$)</b>	<b>Qty</b>	<b>Amount</b>
1 Lodgment Of Return Of Allotment Of Share	10.00	1	10.00
<b>COMPANY NAME :</b> 197201770G / SINGAPORE AIRPORT TERMINAL SERVICES LIMITED			
<b>Total (S\$) :</b>			10.00

---

**Deposit Service Account No. : 030066**  
**Balance Amount in Deposit Account : \$ 215.00**

This is a computer-generated receipt. No signature is required.

Please print a copy of the receipt for your reference.

[HOME](#)[LOGOUT](#)



**Return of Allotment of Shares**

Submit

Please fill in the following information. Fields marked \* must be completed.

Resolution/Declaration	Shares payable in cash	For a consideration other than cash	Share Capital/Allottees Particulars	List of Shareholders after the allotment	Summary of Capital
------------------------	---------------------------	---	---	---	-----------------------

**Record saved successfully.****Company Type**

Please click on appropriate button :

- company is listed on the securities exchange  
 company is an unlisted public company  
 company is a private company

**Power under Section 161 of the Companies Act \***

The directors have obtained the approval of the company in  Yes  
 general meeting to issue  No  
 shares.

**Resolution Made**

\* You are only required to fill in this section if the directors are not given the power under Section 161 of the Companies Act to issue shares.

Registration No. : **197201770G**Company Name : **SINGAPORE AIRPORT TERMINAL SERVICES LIMITED**

Nature of Meeting : \* Directors

Place of Meeting : \*

Date of Meeting : \* (dd/mm/yyyy)

Resolution Type : \* Director's

Description : \*  
(max 2000 characters)Attachment : \*  
(copy of resolution)**Note :**

Uploaded file name will be changed by suffixing time-stamp with the actual file name as

filenameyyyyMMddmmsstt

Browse...

(Click 'Browse' to select file for attachment)

**Persons signing the resolution**

Please indicate the directors/ secretaries who signed the resolution :

- S0036442H / OW CHIN HOCK
- S0070715E / NG KEE CHOE
- S0234645A / CHEW CHOON SENG
- S1001765C / BARRY HENRY PATRICK DESKER
- S1069567H / TAN JIAK NGEE MICHAEL
- S1673157I / YIP WAI PING ANNABELLE
- S1852301I / HONG HAI @ HUANG HAI
- S2163476Z / CHENG WAI WING EDMUND
- S2580327B / RICHARD CHARLES HELFER

Please enter names of other corporate representatives who signed the resolution, if applicable :

**Declaration**

I, LIM HONG ENG SUSANNA, Professional body/service bureau, declare the information which has been submitted herein to be true to the best of my knowledge.

**Return of Allotment of Shares**

**Submit**

Please fill in the following information. Fields marked \* must be completed.

<u>Resolution / Declaration</u>	<u>Share payable in cash</u>	<u>For a consideration other than cash</u>	<u>Share Capital / Allottees Particulars</u>	<u>List of Shareholders after the Allotment</u>	<u>Summary of Capital</u>
---------------------------------	------------------------------	--	--	---	---------------------------

**Authorised Capital**

	<u>Amount</u>	<u>Nominal Value per Share</u>	<u>Currency</u>
Authorised Capital :	<b>200000000</b>	<b>.1</b>	<b>SINGAPORE DOLLAR ( 099 )</b>

Description of discrepancy :

**Return of Allotment of Shares (Payable in cash) \***

Applicable only if share is payable in cash

<u>Class of Shares :</u>	<u>Ordinary</u>	<u>Preference</u>	<u>Others</u>
Number of shares :	<input checked="checked" type="text" value="32500"/>	<input type="text"/>	<input type="text"/>
Amount paid or due and payable on each share			
paid :	<input type="text" value="0.10"/>	<input type="text"/>	<input type="text"/>
due and payable :	<input type="text" value="0"/>	<input type="text"/>	<input type="text"/>
Amount of premium paid or payable on each share :	<input checked="checked" type="text" value="1.14"/>	<input type="text"/>	<input type="text"/>

**Save**    **Delete Issued Share**    **Reset**    **Back**

**LOCAL COMPANY TRANSACTIONS**[HOME](#) [LOGOUT](#)**Return of Allotment of Shares**[Submit](#)

Please fill in the following information. Fields marked \* must be completed.

<u>Resolution / Declaration</u>	<u>Share payable in cash</u>	<u>For a consideration other than cash</u>	<u>Share Capital / Allottees Particulars</u>	<u>List of Shareholders after the allotment</u>	<u>Summary of Capital</u>
---------------------------------	------------------------------	--	--	---	---------------------------

**Particulars of Allottee****Please indicate whether the allottee is an Individual : \***

- Allottee is an Individual
- Allottee is NOT an Individual

**If Allottee is an Individual :**Shareholder Category : \* **Individual**Identification No. : \*  [Retrieve Details](#)Identification Type : \* Name : \* Nationality : \* Mobile No : Occupation : Email Address : Address Type : \*  Local  Foreign

Local Address (\* if Address Type is Local Address)

Postal Code :  [Retrieve Address](#)Block/House No. : Street Name : Unit : #  - Building/Estate Name : 

Foreign Address (\* if Address Type is Foreign Address)

Address :   
**If Allottee is NOT an Individual :**Shareholder Category : \*  [Search](#)

Registration NO. : \*    
Name : **THE CENTRAL DEPOSITORY (PTE) LIMITED**

Address Type : **Local**

Local Address (\* if Address Type is Local Address)

Postal Code : **068804**

Block/House No. : **2**

Street Name : **SHENTON WAY**

Unit : # **19 - 00**

Building/Estate Name : **SGX CENTRE I**

Foreign Address (\* if Address Type is Foreign Address)

Address :

**Details of Shares Allotted** \* Please read instructions carefully before entering.

Note : If any share or shares is/are co-owned by 2 or more persons, please assign an alphabet e.g. **A** to denote the Group and enter the same in the box. Enter the same alphabet in the box for every allottee in the same group. Skip this box if share(s) are owned by only one person.

Group of Share that is co-owned:  
(Share Group)

If share(s) is/are co-owned, only one allottee is to enter details in (a), (b), (c), (d) and (e). Enter "0" (zero) for subsequent allottees in box (b) and leave blank for rest of the items.

a) Nominal Value per Share :  ✓

b) No. of shares allotted :  ✓

c) Class of shares allotted :  ▼ ✓

d) Currency :  ▼

e) Date of allotment :  (dd/mm/yyyy)

**Return of Allotment of Shares****Submit**

Please fill in the following information. Fields marked \* must be completed.

<b>Resolution / Declaration</b>	<b>Share payable in cash</b>	<b>For a consideration other than cash</b>	<b>Share Capital / Allottees Particulars</b>	<b>List of Shareholders after Allotment</b>	<b>Summary of Capital</b>
-------------------------------------	----------------------------------	--	--	---	-------------------------------

**List of Allottees and their particulars****Identification****No./Registration Name  
No.****Shareholder Category**

198003912M	THE CENTRAL DEPOSITORY (PTE) LIMITED	Company / Foreign Branch
------------	---	--------------------------

If No. of shareholders exceeds 50, total No. of issued shares held by the remaining shareholders are :

<b>No. of Shares</b>	<b>Ordinary</b>	<b>Preference</b>	<b>Others</b>
	0	0	0

**Return of Allotment of Shares****Submit**

Please fill in the following information. Fields marked \* must be completed.

<u>Resolution / Declaration</u>	<u>Share payable in cash</u>	<u>For a consideration other than cash</u>	<u>Share Capital / Allottees Particulars</u>	<u>List of Shareholders after the allotment</u>	<u>Summary of Capital</u>
<b>Share Capital (1)</b>					
Currency :	<b>SINGAPORE DOLLAR (099)</b>				
Nominal Value per Share :	<b>0.10</b>				
Amount of Authorised Share Capital :	<b>200000000.00</b>				
Class of Shares :	Ordinary	Preference	Others		
Amount of Issued Share Capital :	<b>102553357.50</b>	<b>0.00</b>	<b>0.00</b>		
Amount of Paid-up Share Capital :	<b>102553357.50</b>	<b>0.00</b>	<b>0.00</b>		

**RECEIPT**

Receipt No : ACR0000000902405A

Date/Time : 21/10/2004 09:09

Transaction  
No : C040477157

Agency : RCB - RCB

Application : BIZFILE PAYMENT SERVICE

Paid via : Deposit Service Account

EP Ref No :

**SINGAPORE AIRPORT TERMINAL SERVICES LIMITED  
20 AIRPORT BOULEVARD  
SATS INFLIGHT CATERING CENTRE 3  
SINGAPORE 819659**

---

<b>Sno Code/Description</b>	<b>Unit Price (S\$)</b>	<b>Qty</b>	<b>Amount</b>
1 Lodgment Of Return Of Allotment Of Share <b>COMPANY NAME :</b> 197201770G / SINGAPORE AIRPORT TERMINAL SERVICES LIMITED	10.00	1	10.00
<hr/>			
			<b>Total (S\$) :</b>
			10.00

---

**Deposit Service Account No. : 030066****Balance Amount in Deposit Account : \$ 225.00**

This is a computer-generated receipt. No signature is required.

Please print a copy of the receipt for your reference.

[HOME](#)[LOGOUT](#)



**Return of Allotment of Shares****Submit**

Please fill in the following information. Fields marked \* must be completed.

Resolution/Declaration	Shares payable in cash	For a consideration other than cash	Share Capital/Allottees Particulars	List of Shareholders after the allotment	Summary of Capital
------------------------	---------------------------	---	---	---	-----------------------

**Record saved successfully.****Company Type**

Please click on appropriate button :

- company is listed on the securities exchange
- company is an unlisted public company
- company is a private company

**Power under Section 161 of the Companies Act \***

The directors have obtained  
the approval of the company in  Yes  
general meeting to issue  No  
shares.

**Resolution Made**

\* You are only required to fill in this section if the directors are not given the power under Section 161 of the Companies Act to issue shares.

Registration No. : **197201770G**Company Name : **SINGAPORE AIRPORT TERMINAL SERVICES LIMITED**Nature of Meeting : \* **Directors** ▼

Place of Meeting : \*

Date of Meeting : \*  (dd/mm/yyyy)Resolution Type : \* **Director's** ▼Description : \*  
(max 2000 characters)
Attachment : \*  
(copy of resolution)**Note :**

Uploaded file name will be  
changed by suffixing time-  
stamp with the actual file  
name as

 **Browse...**

(Click 'Browse' to select file for attachment)

**filenameyyyyMMddmmsstt**

**Persons signing the resolution**

Please indicate the directors/ secretaries who signed the resolution :

- S0036442H / OW CHIN HOCK
- S0070715E / NG KEE CHOE
- S0234645A / CHEW CHOON SENG
- S1001765C / BARRY HENRY PATRICK DESKER
- S1069567H / TAN JIAK NGEE MICHAEL
- S1673157I / YIP WAI PING ANNABELLE
- S1852301I / HONG HAI @ HUANG HAI
- S2163476Z / CHENG WAI WING EDMUND
- S2580327B / RICHARD CHARLES HELFER

Please enter  
names of other  
corporate  
representatives  
who signed the  
resolution, if  
applicable :

**Declaration**

I, LIM HONG ENG SUSANNA, Professional body/service bureau, declare the information which has been submitted herein to be true to the best of my knowledge.

**Return of Allotment of Shares**

**Submit**

Please fill in the following information. Fields marked \* must be completed.

<b>Resolution / Declaration</b>	<b>Share payable in cash</b>	<b>For a consideration other than cash</b>	<b>Share Capital / Allottees Particulars</b>	<b>List of Shareholders after the Allotment</b>	<b>Summary of Capital</b>
---------------------------------	------------------------------	--	--	---	---------------------------

**Authorised Capital**

	<b>Amount</b>	<b>Nominal Value per Share</b>	<b>Currency</b>
Authorised Capital :	<b>200000000</b>	<b>.1</b>	<b>SINGAPORE DOLLAR ( 099 )</b>

Description of discrepancy :

**Return of Allotment of Shares (Payable in cash) \***

Applicable only if share is payable in cash

<b>Class of Shares :</b>	<b>Ordinary</b>	<b>Preference</b>	<b>Others</b>
Number of shares :	<input type="text" value="44200"/>	<input type="text"/>	<input type="text"/>
Amount paid or due and payable on each share			
paid :	<input type="text" value="0.10"/>	<input type="text"/>	<input type="text"/>
due and payable :	<input type="text" value="0"/>	<input type="text"/>	<input type="text"/>
Amount of premium paid or payable on each share :	<input type="text" value="1.70"/>	<input type="text"/>	<input type="text"/>

**Save**    **Delete Issued Share**    **Reset**    **Back**

**Return of Allotment of Shares****Submit**

Please fill in the following information. Fields marked \* must be completed.

<b>Resolution / Declaration</b>	<b>Share payable in cash</b>	<b>For a consideration other than cash</b>	<b>Share Capital / Allottees Particulars</b>	<b>List of Shareholders after the allotment</b>	<b>Summary of Capital</b>
-------------------------------------	----------------------------------	--	--	---	-------------------------------

**Particulars of Allottee**

Please indicate whether the allottee is an Individual : \*

- Allottee is an Individual  
 Allottee is NOT an Individual

If Allottee is an Individual :

Shareholder Category : \* **Individual**Identification No. : \*  **Retrieve Details**Identification Type : \*  Name : \* Nationality : \*  Mobile No : Occupation : Email Address : Address Type : \*  
 Local  
 Foreign

Local Address (\* if Address Type is Local Address)

Postal Code :  **Retrieve Address**Block/House No. :  

Street Name :

Unit : #  - 

Building/Estate Name :

Foreign Address (\* if Address Type is Foreign Address)

Address :   

If Allottee is NOT an Individual :

Shareholder Category : \*   **Search**

Registration No. : \*

198003912M

Retrieve Details

Name :

**THE CENTRAL DEPOSITORY (PTE) LIMITED**

Address Type :

**Local**

Local Address (\* if Address Type is Local Address)

Postal Code : **068804**

Block/House No. : **2**

Street Name : **SHENTON WAY**

Unit : # **19 - 00**

.Building/Estate Name : **SGX CENTRE I**

Foreign Address (\* if Address Type is Foreign Address)

Address :

**Details of Shares Allotted** \* Please read instructions carefully before entering.

Note : If any share or shares is/are co-owned by 2 or more persons, please assign an alphabet e.g. A to denote the Group and enter the same in the box. Enter the same alphabet in the box for every allottee in the same group. Skip this box if share(s) are owned by only one person.

Group of Share that is co-owned:  
(Share Group)

If share(s) is/are co-owned, only one allottee is to enter details in (a), (b), (c), (d) and (e). Enter "0" (zero) for subsequent allottees in box (b) and leave blank for rest of the items.

a) Nominal Value per Share :

0.10

b) No. of shares allotted :

44200

c) Class of shares allotted :

Ordinary

d) Currency :

SINGAPORE DOLLAR (099)

e) Date of allotment :

15/10/2004 (dd/mm/yyyy)

Save

Reset

Back

**Return of Allotment of Shares****Submit**

Please fill in the following information. Fields marked \* must be completed.

<b>Resolution / Declaration</b>	<b>Share payable in cash</b>	<b>For a consideration other than cash</b>	<b>Share Capital / Allottees Particulars</b>	<b>List of Shareholders after Allotment</b>	<b>Summary of Capital</b>
-------------------------------------	----------------------------------	--	--	---	-------------------------------

**List of Allottees and their particulars****Identification****No./Registration Name  
No.****Shareholder Category**

198003912M	THE CENTRAL DEPOSITORY (PTE) LIMITED	Company / Foreign Branch
------------	---	--------------------------

If No. of shareholders exceeds 50, total No. of issued shares held by the remaining shareholders are :

	<b>Ordinary</b>	<b>Preference</b>	<b>Others</b>
<b>No. of Shares</b>	<b>0</b>	<b>0</b>	<b>0</b>

**Return of Allotment of Shares****Submit**

Please fill in the following information. Fields marked \* must be completed.

Resolution / Declaration	Share payable in cash	For a consideration other than cash	Share Capital / Allottees Particulars	List of Shareholders after the allotment	Summary of Capital
--------------------------	-----------------------	-------------------------------------	---------------------------------------	--	--------------------

**Share Capital (1)**

Currency :	<b>SINGAPORE DOLLAR (099)</b>			
Nominal Value per Share :	<b>0.10</b>			
Amount of Authorised Share Capital :	<b>200000000.00</b>			
Class of Shares :	Ordinary	Preference	Others	
Amount of Issued Share Capital :	<b>102550107.50</b>	<b>0.00</b>	<b>0.00</b>	
Amount of Paid-up Share Capital :	<b>102550107.50</b>	<b>0.00</b>	<b>0.00</b>	

GST No. :M9-0008879-T

**RECEIPT**

Receipt No : ACR0000000899251A

Date/Time : 19/10/2004 12:07

Transaction  
No : C040473732

Agency : RCB - RCB

Application : BIZFILE PAYMENT SERVICE

Paid via : Deposit Service Account

EP Ref No :

**SINGAPORE AIRPORT TERMINAL SERVICES LIMITED  
20 AIRPORT BOULEVARD  
SATS INFLIGHT CATERING CENTRE 3  
SINGAPORE 819659**

Sno	Code/Description	Unit Price (S\$)	Qty	Amount
1	Lodgment Of Return Of Allotment Of Share <b>COMPANY NAME :</b> 197201770G / SINGAPORE AIRPORT TERMINAL SERVICES LIMITED	10.00	1	10.00
<b>Total (S\$) :</b>				<b>10.00</b>

**Deposit Service Account No. : 030066**  
**Balance Amount in Deposit Account : \$ 235.00**

This is a computer-generated receipt. No signature is required.

Please print a copy of the receipt for your reference.

[HOME](#)[LOGOUT](#)



**Return of Allotment of Shares**

Submit

Please fill in the following information. Fields marked \* must be completed.

Resolution/Declaration	Shares payable in cash	For a consideration other than cash	Share Capital/Allottees Particulars	List of Shareholders after the allotment	Summary of Capital
------------------------	---------------------------	---	---	---	-----------------------

Record saved successfully.

**Company Type**

Please click on appropriate button :

- company is listed on the securities exchange  
 company is an unlisted public company  
 company is a private company

**Power under Section 161 of the Companies Act \***

The directors have obtained the approval of the company in  Yes  
 general meeting to issue  No shares.

**Resolution Made**

\* You are only required to fill in this section if the directors are not given the power under Section 161 of the Companies Act to issue shares.

Registration No. : **197201770G**Company Name : **SINGAPORE AIRPORT TERMINAL SERVICES LIMITED**

Nature of Meeting : \* Directors

Place of Meeting : \*

Date of Meeting : \* (dd/mm/yyyy)

Resolution Type : \* Director's

Description : \*  
(max 2000 characters)Attachment : \*  
(copy of resolution)**Note :**

Uploaded file name will be changed by suffixing time-stamp with the actual file name as

filenameyyyyMMddmmsstt

Browse...

(Click 'Browse' to select file for attachment)

**Persons signing the resolution**

Please indicate the directors/ secretaries who signed the resolution :

- S0036442H / OW CHIN HOCK
- S0070715E / NG KEE CHOE
- S0234645A / CHEW CHOON SENG
- S1001765C / BARRY HENRY PATRICK DESKER
- S1069567H / TAN JIAK NGEE MICHAEL
- S1673157I / YIP WAI PING ANNABELLE
- S1852301I / HONG HAI @ HUANG HAI
- S2163476Z / CHENG WAI WING EDMUND
- S2580327B / RICHARD CHARLES HELFER

Please enter names of other corporate representatives who signed the resolution, if applicable :

**Declaration**

I, LIM HONG ENG SUSANNA, Professional body/service bureau, declare the information which has been submitted herein to be true to the best of my knowledge.

**Return of Allotment of Shares**

[Submit](#)

Please fill in the following information. Fields marked \* must be completed.

<u>Resolution / Declaration</u>	<u>Share payable in cash</u>	<u>For a consideration other than cash</u>	<u>Share Capital / Allottees Particulars</u>	<u>List of Shareholders after the Allotment</u>	<u>Summary of Capital</u>
---------------------------------	------------------------------	--	--	---	---------------------------

**Authorised Capital**

	<u>Amount</u>	<u>Nominal Value per Share</u>	<u>Currency</u>
Authorised Capital :	<b>200000000</b>	<b>.1</b>	<b>SINGAPORE DOLLAR ( 099 )</b>

Description of discrepancy :

**Return of Allotment of Shares (Payable in cash) \***

Applicable only if share is payable in cash

<u>Class of Shares :</u>	<u>Ordinary</u>	<u>Preference</u>	<u>Others</u>
Number of shares :	<input type="text" value="72800"/>	<input type="text"/>	<input type="text"/>
Amount paid or due and payable on each share			
paid :	<input type="text" value="0.10"/>	<input type="text"/>	<input type="text"/>
due and payable :	<input type="text" value="0"/>	<input type="text"/>	<input type="text"/>
Amount of premium paid or payable on each share :	<input type="text" value="1.50"/>	<input type="text"/>	<input type="text"/>

[Save](#) [Delete Issued Share](#) [Reset](#) [Back](#)

**Return of Allotment of Shares****Submit**

Please fill in the following information. Fields marked \* must be completed.

<u>Resolution / Declaration</u>	<u>Share payable in cash</u>	<u>For a consideration other than cash</u>	<u>Share Capital / Allottees Particulars</u>	<u>List of Shareholders after the allotment</u>	<u>Summary of Capital</u>
---------------------------------	------------------------------	--	--	---	---------------------------

**Particulars of Allottee****Please indicate whether the allottee is an Individual : \***

- Allottee is an Individual
- Allottee is NOT an Individual

**If Allottee is an Individual :**Shareholder Category : \* **Individual**Identification No. : \*  **Retrieve Details**Identification Type : \*  Name : \* Nationality : \*  Mobile No : Occupation : Email Address : Address Type : \*  Local  
 Foreign

Local Address (\* if Address Type is Local Address)

Postal Code :  **Retrieve Address**Block/House No. : 

Street Name :

Unit : #  - 

Building/Estate Name :

Foreign Address (\* if Address Type is Foreign Address)

Address :   
**If Allottee is NOT an Individual :**Shareholder Category : \*   **Search**

Registration No. : \*

198003912M

Retrieve Details

Name :

**THE CENTRAL DEPOSITORY (PTE) LIMITED**

Address Type :

**Local**

Local Address (\* if Address Type is Local Address)

Postal Code : **068804**

Block/House No. : **2**

Street Name : **SHENTON WAY**

Unit : # **19 - 00**

Building/Estate Name : **SGX CENTRE I**

Foreign Address (\* if Address Type is Foreign Address)

Address :

**Details of Shares Allotted** \* Please read instructions carefully before entering.

Note : If any share or shares is/are co-owned by 2 or more persons, please assign an alphabet e.g. A to denote the Group and enter the same in the box. Enter the same alphabet in the box for every allottee in the same group. Skip this box if share(s) are owned by only one person.

Group of Share that is co-owned:  
(Share Group)

If share(s) is/are co-owned, only one allottee is to enter details in (a), (b), (c), (d) and (e). Enter "0" (zero) for subsequent allottees in box (b) and leave blank for rest of the items.

a) Nominal Value per Share :

0.10

b) No. of shares allotted :

72800

c) Class of shares allotted :

Ordinary

d) Currency :

SINGAPORE DOLLAR (099)

e) Date of allotment :

13/10/2004

(dd/mm/yyyy)

Save

Reset

Back

**Return of Allotment of Shares****Submit**

Please fill in the following information. Fields marked \* must be completed.

<b>Resolution / Declaration</b>	<b>Share payable in cash</b>	<b><u>For a consideration other than cash</u></b>	<b><u>Share Capital / Allottees Particulars</u></b>	<b>List of Shareholders after Allotment</b>	<b>Summary of Capital</b>
-------------------------------------	----------------------------------	---	---	---	-------------------------------

**List of Allottees and their particulars****Identification****No./Registration Name  
No.****Shareholder Category**

198003912M	THE CENTRAL DEPOSITORY (PTE) LIMITED	Company / Foreign Branch
------------	---	--------------------------

If No. of shareholders exceeds 50, total No. of issued shares held by the remaining shareholders are :

<b>No. of Shares</b>	<b>Ordinary</b>	<b>Preference</b>	<b>Others</b>
	0	0	0

**LOCAL COMPANY TRANSACTIONS****HOME**      **LOGOUT****Return of Allotment of Shares****Submit**

Please fill in the following information. Fields marked \* must be completed.

<u>Resolution / Declaration</u>	<u>Share payable in cash</u>	<u>For a consideration other than cash</u>	<u>Share Capital / Allottees Particulars</u>	<u>List of Shareholders after the allotment</u>	<u>Summary of Capital</u>
---------------------------------	------------------------------	--	--	---	---------------------------

**Share Capital (1)**

Currency :	<b>SINGAPORE DOLLAR (099)</b>		
Nominal Value per Share :	<b>0.10</b>		
Amount of Authorised Share Capital :	<b>200000000.00</b>		
Class of Shares :	Ordinary	Preference	Others
Amount of Issued Share Capital :	<b>102545687.50</b>	<b>0.00</b>	<b>0.00</b>
Amount of Paid-up Share Capital :	<b>102545687.50</b>	<b>0.00</b>	<b>0.00</b>

GST No. :M9-0008879-T

**RECEIPT**

Receipt No : ACR0000000899211A

Date/Time : 19/10/2004 11:55

Transaction  
No : C040473687

Agency : RCB - RCB

Application : BIZFILE PAYMENT SERVICE

Paid via : Deposit Service Account

EP Ref No :

**SINGAPORE AIRPORT TERMINAL SERVICES LIMITED**  
**20 AIRPORT BOULEVARD**  
**SATS INFLIGHT CATERING CENTRE 3**  
**SINGAPORE 819659**

<b>Sno Code/Description</b>	<b>Unit Price (S\$)</b>	<b>Qty</b>	<b>Amount</b>
1 Lodgment Of Return Of Allotment Of Share <b>COMPANY NAME :</b> 197201770G / SINGAPORE AIRPORT TERMINAL SERVICES LIMITED	10.00	1	10.00
<b>Total (S\$) :</b>			<b>10.00</b>

**Deposit Service Account No. : 030066**  
**Balance Amount in Deposit Account : \$ 245.00**

This is a computer-generated receipt. No signature is required.

Please print a copy of the receipt for your reference.

[HOME](#)[LOGOUT](#)



**Return of Allotment of Shares****Submit**

Please fill in the following information. Fields marked \* must be completed.

Resolution/Declaration	Shares payable in cash	For a consideration other than cash	Share Capital/Allottees Particulars	List of Shareholders after the allotment	Summary of Capital
------------------------	---------------------------	---	---	---	-----------------------

**Record saved successfully.****Company Type**

Please click on appropriate button :

- company is listed on the securities exchange
- company is an unlisted public company
- company is a private company

**Power under Section 161 of the Companies Act \***

The directors have obtained  
the approval of the company in  Yes  
general meeting to issue  No  
shares.

**Resolution Made**

\* You are only required to fill in this section if the directors are not given the power under Section 161 of the Companies Act to issue shares.

Registration No. : **197201770G**Company Name : **SINGAPORE AIRPORT TERMINAL SERVICES LIMITED**Nature of Meeting : \* **Directors**

Place of Meeting : \*

Date of Meeting : \* (dd/mm/yyyy)

Resolution Type : \* **Director's**Description : \*  
(max 2000 characters)Attachment : \*  
(copy of resolution)**Note :**

Uploaded file name will be  
changed by suffixing time-  
stamp with the actual file  
name as

**filenameyyyyMMddmmsstt****Browse...**

(Click 'Browse' to select file for attachment)

**Persons signing the resolution**

Please indicate the directors/ secretaries who signed the resolution :

- S0036442H / OW CHIN HOCK
- S0070715E / NG KEE CHOE
- S0234645A / CHEW CHOON SENG
- S1001765C / BARRY HENRY PATRICK DESKER
- S1069567H / TAN JIAK NGEE MICHAEL
- S1673157I / YIP WAI PING ANNABELLE
- S1852301I / HONG HAI @ HUANG HAI
- S2163476Z / CHENG WAI WING EDMUND
- S2580327B / RICHARD CHARLES HELFER

Please enter names of other corporate representatives who signed the resolution, if applicable :

**Declaration**

I, LIM HONG ENG SUSANNA, Professional body/service bureau, declare the information which has been submitted herein to be true to the best of my knowledge.

**Return of Allotment of Shares**

Please fill in the following information. Fields marked \* must be completed.

<b>Resolution / Declaration</b>	<b>Share payable in cash</b>	<b>For a consideration other than cash</b>	<b>Share Capital / Allottees Particulars</b>	<b>List of Shareholders after the Allotment</b>	<b>Summary of Capital</b>
-------------------------------------	----------------------------------	--	--	---	-------------------------------

**Authorised Capital**

	<b>Amount</b>	<b>Nominal Value per Share</b>	<b>Currency</b>
Authorised Capital :	<b>20000000</b>	<b>.1</b>	<b>SINGAPORE DOLLAR ( 099 )</b>

Description of discrepancy :

**Return of Allotment of Shares (Payable in cash) \***

Applicable only if share is payable in cash

<b>Class of Shares :</b>	<b>Ordinary</b>	<b>Preference</b>	<b>Others</b>
Number of shares :	<input type="text" value="20800"/>	<input type="text"/>	<input type="text"/>
Amount paid or due and payable on each share			
paid :	<input type="text" value="0.10"/>	<input type="text"/>	<input type="text"/>
due and payable :	<input type="text" value="0"/>	<input type="text"/>	<input type="text"/>
Amount of premium paid or payable on each share :	<input type="text" value="1.14"/>	<input type="text"/>	<input type="text"/>

**Return of Allotment of Shares****Submit**

Please fill in the following information. Fields marked \* must be completed.

Resolution / Declaration	Share payable in cash	For a consideration other than cash	Share Capital / Allottees Particulars	List of Shareholders after the allotment	Summary of Capital
--------------------------	-----------------------	-------------------------------------	---------------------------------------	--	--------------------

**Particulars of Allottee**

Please indicate whether the allottee is an Individual : \*

- Allottee is an Individual  
 Allottee is NOT an Individual ✓

**If Allottee is an Individual :**Shareholder Category : \* **Individual**

Identification No. : \*

**Retrieve Details**

Identification Type : \*

NRIC 

Name : \*

Nationality : \*

Mobile No :

Occupation :

Email Address :

Address Type : \*

- Local  
 Foreign

Local Address (\* if Address Type is Local Address)

Postal Code :

**Retrieve Address**

Block/House No. :

Street Name :

Unit : #

 - 

Building/Estate Name :

Foreign Address (\* if Address Type is Foreign Address)

Address :

**If Allottee is NOT an Individual :**

Shareholder Category : \*

Company / Foreign Branch **Search**

Registration No. : \*

198003912M

Retrieve Details

Name :

**THE CENTRAL DEPOSITORY (PTE) LIMITED**

Address Type :

**Local**

Local Address (\* if Address Type is Local Address)

Postal Code : **068804**

Block/House No. : **2**

Street Name : **SHENTON WAY**

Unit : # **19 - 00**

Building/Estate Name : **SGX CENTRE I**

Foreign Address (\* if Address Type is Foreign Address)

Address :

**Details of Shares Allotted** \* Please read instructions carefully before entering.

Note : If any share or shares is/are co-owned by 2 or more persons, please assign an alphabet e.g. A to denote the Group and enter the same in the box. Enter the same alphabet in the box for every allottee in the same group. Skip this box if share(s) are owned by only one person.

Group of Share that is co-owned:  
(Share Group)

If share(s) is/are co-owned, only one allottee is to enter details in (a), (b), (c), (d) and (e). Enter "0" (zero) for subsequent allottees in box (b) and leave blank for rest of the items.

a) Nominal Value per Share :

0.10

b) No. of shares allotted :

20800

c) Class of shares allotted :

Ordinary

d) Currency :

SINGAPORE DOLLAR (099)

e) Date of allotment :

13/10/2004

(dd/mm/yyyy)

Save

Reset

Back

**Return of Allotment of Shares****Submit**

Please fill in the following information. Fields marked \* must be completed.

Resolution / Declaration	Share payable in cash	For a consideration other than cash	Share Capital / Allottees Particulars	List of Shareholders after Allotment	Summary of Capital
-----------------------------	--------------------------	---	---	--	-----------------------

**List of Allottees and their particulars****Identification**

**No./Registration Name  
No.**

**Shareholder Category**

198003912M	THE CENTRAL DEPOSITORY (PTE) LIMITED	Company / Foreign Branch
------------	---	--------------------------

If No. of shareholders exceeds 50, total No. of issued shares held by the remaining shareholders are :

No. of Shares	Ordinary	Preference	Others
	0	0	0

**Return of Allotment of Shares****Submit**

Please fill in the following information. Fields marked \* must be completed.

Resolution / Declaration	Share payable in cash	For a consideration other than cash	Share Capital / Allottees Particulars	List of Shareholders after the allotment	Summary of Capital
<b>Share Capital (1)</b>					
Currency :	<b>SINGAPORE DOLLAR (099)</b>				
Nominal Value per Share :	<b>0.10</b>				
Amount of Authorised Share Capital :	<b>200000000.00</b>				
Class of Shares :	Ordinary	Preference	Others		
Amount of Issued Share Capital :	<b>102538407.50</b>	<b>0.00</b>	<b>0.00</b>		
Amount of Paid-up Share Capital :	<b>102538407.50</b>	<b>0.00</b>	<b>0.00</b>		

GST No. : M9-0008879-T

**RECEIPT**

Receipt No : ACR0000000898765A

Date/Time : 19/10/2004 09:39

Transaction No : C040473187

Agency : RCB - RCB

Application : BIZFILE PAYMENT SERVICE

Paid via : Deposit Service Account

EP Ref No :

**SINGAPORE AIRPORT TERMINAL SERVICES LIMITED  
20 AIRPORT BOULEVARD  
SATS INFLIGHT CATERING CENTRE 3  
SINGAPORE 819659**

---

<b>Sno Code/Description</b>	<b>Unit Price (S\$)</b>	<b>Qty</b>	<b>Amount</b>
1 Lodgment Of Return Of Allotment Of Share <b>COMPANY NAME :</b> 197201770G / SINGAPORE AIRPORT TERMINAL SERVICES LIMITED	10.00	1	10.00
<b>Total (S\$) :</b>			10.00

---

**Deposit Service Account No. : 030066**  
**Balance Amount in Deposit Account : \$ 255.00**

This is a computer-generated receipt. No signature is required.

Please print a copy of the receipt for your reference.

[HOME](#)[LOGOUT](#)



**Return of Allotment of Shares****Submit**

Please fill in the following information. Fields marked \* must be completed.

Resolution/Declaration	Shares payable in cash	For a consideration other than cash	Share Capital/Allottees Particulars	List of Shareholders after the allotment	Summary of Capital
------------------------	------------------------	-------------------------------------	-------------------------------------	--	--------------------

**Record saved successfully.****Company Type**

Please click on appropriate button :

- company is listed on the securities exchange
- company is an unlisted public company
- company is a private company

**Power under Section 161 of the Companies Act \***

The directors have obtained the approval of the company in  Yes  No general meeting to issue shares.

**Resolution Made**

\* You are only required to fill in this section if the directors are not given the power under Section 161 of the Companies Act to issue shares.

Registration No. : **197201770G**Company Name : **SINGAPORE AIRPORT TERMINAL SERVICES LIMITED**Nature of Meeting : \* **Directors** ▼

Place of Meeting : \*

Date of Meeting : \*  (dd/mm/yyyy)Resolution Type : \* **Director's** ▼Description : \*  
(max 2000 characters)
Attachment : \*  
(copy of resolution)**Note :**

Uploaded file name will be changed by suffixing time-stamp with the actual file name as

**filenameyyyyMMddmmsstt** **Browse...**

(Click 'Browse' to select file for attachment)

**Persons signing the resolution**

Please indicate the directors/ secretaries who signed the resolution :

- S0036442H / OW CHIN HOCK
- S0070715E / NG KEE CHOE
- S0234645A / CHEW CHOON SENG
- S1001765C / BARRY HENRY PATRICK DESKER
- S1069567H / TAN JIAK NGEE MICHAEL
- S1673157I / YIP WAI PING ANNABELLE
- S1852301I / HONG HAI @ HUANG HAI
- S2163476Z / CHENG WAI WING EDMUND
- S2580327B / RICHARD CHARLES HELFER

Please enter names of other corporate representatives who signed the resolution, if applicable :

**Declaration**

I, LIM HONG ENG SUSANNA, Professional body/service bureau, declare the information which has been submitted herein to be true to the best of my knowledge.

**Return of Allotment of Shares**

[Submit](#)

Please fill in the following information. Fields marked \* must be completed.

Resolution / Declaration	Share payable in cash	For a consideration other than cash	Share Capital / Allottees Particulars	List of Shareholders after the Allotment	Summary of Capital
--------------------------	-----------------------	-------------------------------------	---------------------------------------	--	--------------------

**Authorised Capital**

	Amount	Nominal Value per Share	Currency
Authorised Capital :	<b>200000000</b>	<b>.1</b>	<b>SINGAPORE DOLLAR ( 099 )</b>

Description of discrepancy :

**Return of Allotment of Shares (Payable in cash) \***

Applicable only if share is payable in cash

Class of Shares :	Ordinary	Preference	Others
Number of shares :	<input type="text" value="50700"/>	<input type="text"/>	<input type="text"/>
Amount paid or due and payable on each share			
paid :	<input type="text" value="0.10"/>	<input type="text"/>	<input type="text"/>
due and payable :	<input type="text" value="0"/>	<input type="text"/>	<input type="text"/>
Amount of premium paid or payable on each share :	<input type="text" value="1.70"/>	<input type="text"/>	<input type="text"/>

[Save](#) [Delete Issued Share](#) [Reset](#) [Back](#)

**Return of Allotment of Shares****Submit**

Please fill in the following information. Fields marked \* must be completed.

Resolution / Declaration	Share payable in cash	For a consideration other than cash	Share Capital / Allottees Particulars	List of Shareholders after the allotment	Summary of Capital
--------------------------	-----------------------	-------------------------------------	---------------------------------------	--	--------------------

**Particulars of Allottee**

Please indicate whether the allottee is an Individual : \*

- Allottee is an Individual  
 Allottee is NOT an Individual

If Allottee is an Individual :

Shareholder Category : \* **Individual**

Identification No. : \*

**Retrieve Details**

Identification Type : \*

NRIC 

Name : \*

Nationality : \*

Mobile No. :

Occupation :

Email Address :

Address Type : \*

- Local  
 Foreign

Local Address (\* if Address Type is Local Address)

Postal Code :

**Retrieve Address**

Block/House No. :

Street Name :

Unit : #

 - 

Building/Estate Name :

Foreign Address (\* if Address Type is Foreign Address)

Address :

If Allottee is NOT an Individual :

Shareholder Category : \*

Company / Foreign Branch **Search**

Registration No. : \*

198003912M

Retrieve Details

Name :

**THE CENTRAL DEPOSITORY (PTE) LIMITED**

Address Type :

**Local**

Local Address (\* if Address Type is Local Address)

Postal Code : **068804**

Block/House No. : **2**

Street Name : **SHENTON WAY**

Unit : # **19 - 00**

Building/Estate Name : **SGX CENTRE I**

Foreign Address (\* if Address Type is Foreign Address)

Address :

**Details of Shares Allotted** \* Please read instructions carefully before entering.

Note : If any share or shares is/are co-owned by 2 or more persons, please assign an alphabet e.g. A to denote the Group and enter the same in the box. Enter the same alphabet in the box for every allottee in the same group. Skip this box if share(s) are owned by only one person.

Group of Share that is co-owned:  
(Share Group)

If share(s) is/are co-owned, only one allottee is to enter details in (a), (b), (c), (d) and (e). Enter "0" (zero) for subsequent allottees in box (b) and leave blank for rest of the items.

a) Nominal Value per Share :

0.10

b) No. of shares allotted :

50700

c) Class of shares allotted :

Ordinary

d) Currency :

SINGAPORE DOLLAR (099)

e) Date of allotment :

13/10/2004 (dd/mm/yyyy)

Save

Reset

Back

**Return of Allotment of Shares****Submit**

Please fill in the following information. Fields marked \* must be completed.

<b>Resolution / Declaration</b>	<b>Share payable in cash</b>	<b>For a consideration other than cash</b>	<b>Share Capital / Allottees Particulars</b>	<b>List of Shareholders after Allotment</b>	<b>Summary of Capital</b>
-------------------------------------	----------------------------------	--	--	---	-------------------------------

**List of Allottees and their particulars****Identification****No./Registration Name  
No.****Shareholder Category**

198003912M	THE CENTRAL DEPOSITORY (PTE) LIMITED	Company / Foreign Branch
------------	---	--------------------------

If No. of shareholders exceeds 50, total No. of issued shares held by the remaining shareholders are :

	<b>Ordinary</b>	<b>Preference</b>	<b>Others</b>
<b>No. of Shares</b>	<b>0</b>	<b>0</b>	<b>0</b>

**Return of Allotment of Shares****Submit**

Please fill in the following information. Fields marked \* must be completed.

<b>Resolution / Declaration</b>	<b>Share payable in cash</b>	<b>For a consideration other than cash</b>	<b>Share Capital / Allottees Particulars</b>	<b>List of Shareholders after the allotment</b>	<b>Summary of Capital</b>
<b>Share Capital (1)</b>					
Currency :	<b>SINGAPORE DOLLAR (099)</b>				
Nominal Value per Share :	<b>0.10</b>				
Amount of Authorised Share Capital :	<b>200000000.00</b>				
Class of Shares :	Ordinary	Preference	Others		
Amount of Issued Share Capital :	<b>102536327.50</b>	<b>0.00</b>	<b>0.00</b>		
Amount of Paid-up Share Capital :	<b>102536327.50</b>	<b>0.00</b>	<b>0.00</b>		

**RECEIPT**

Receipt No : ACR0000000897703A

Date/Time : 18/10/2004 14:39

Transaction No : C040472007

Agency : RCB - RCB

Application : BIZFILE PAYMENT SERVICE

Paid via : Deposit Service Account

EP Ref No :

**SINGAPORE AIRPORT TERMINAL SERVICES LIMITED****20 AIRPORT BOULEVARD****SATS INFLIGHT CATERING CENTRE 3****SINGAPORE 819659**

<b>Sno</b>	<b>Code/Description</b>	<b>Unit Price (S\$)</b>	<b>Qty</b>	<b>Amount</b>
1	Lodgment Of Return Of Allotment Of Share <b>COMPANY NAME :</b> 197201770G / SINGAPORE AIRPORT TERMINAL SERVICES LIMITED	10.00	1	10.00
			<b>Total (S\$) :</b>	10.00

**Deposit Service Account No. : 030066****Balance Amount in Deposit Account : \$ 265.00**

This is a computer-generated receipt. No signature is required.

Please print a copy of the receipt for your reference.

[HOME](#)[LOGOUT](#)



**Return of Allotment of Shares**

Submit

Please fill in the following information. Fields marked \* must be completed.

Resolution/Declaration	Shares payable in cash	For a consideration other than cash	Share Capital/Allottees Particulars	List of Shareholders after the allotment	Summary of Capital
------------------------	---------------------------	---	---	---	-----------------------

**Record saved successfully.****Company Type**

Please click on appropriate button :

- company is listed on the securities exchange  
 company is an unlisted public company  
 company is a private company

**Power under Section 161 of the Companies Act \***

The directors have obtained the approval of the company in  Yes  No general meeting to issue shares.

**Resolution Made**

\* You are only required to fill in this section if the directors are not given the power under Section 161 of the Companies Act to issue shares.

Registration No. : **197201770G**Company Name : **SINGAPORE AIRPORT TERMINAL SERVICES LIMITED**

Nature of Meeting : \* Directors

Place of Meeting : \*

Date of Meeting : \* (dd/mm/yyyy)

Resolution Type : \* Director's

Description : \*  
(max 2000 characters)Attachment : \*  
(copy of resolution)**Note :**

Uploaded file name will be changed by suffixing time-stamp with the actual file name as

filenameyyyyMMddmmsstt

Browse...

(Click 'Browse' to select file for attachment)

**Persons signing the resolution**

Please indicate the directors/ secretaries who signed the resolution :

- S0036442H / OW CHIN HOCK
- S0070715E / NG KEE CHOE
- S0234645A / CHEW CHOON SENG
- S1001765C / BARRY HENRY PATRICK DESKER
- S1069567H / TAN JIAK NGEE MICHAEL
- S1673157I / YIP WAI PING ANNABELLE
- S1852301I / HONG HAI @ HUANG HAI
- S2163476Z / CHENG WAI WING EDMUND
- S2580327B / RICHARD CHARLES HELFER

Please enter names of other corporate representatives who signed the resolution, if applicable :

**Declaration**

I, LIM HONG ENG SUSANNA, Professional body/service bureau, declare the information which has been submitted herein to be true to the best of my knowledge.

**Return of Allotment of Shares****Submit**

Please fill in the following information. Fields marked \* must be completed.

<b>Resolution / Declaration</b>	<b>Share payable in cash</b>	<b>For a consideration other than cash</b>	<b>Share Capital / Allottees Particulars</b>	<b>List of Shareholders after the Allotment</b>	<b>Summary of Capital</b>
-------------------------------------	----------------------------------	--	--	---	-------------------------------

**Authorised Capital**

	<b>Amount</b>	<b>Nominal Value per Share</b>	<b>Currency</b>
Authorised Capital :	<b>20000000</b>	<b>.1</b>	<b>SINGAPORE DOLLAR ( 099 )</b>

Description of discrepancy :

**Return of Allotment of Shares (Payable in cash) \***

Applicable only if share is payable in cash

<b>Class of Shares :</b>	<b>Ordinary</b>	<b>Preference</b>	<b>Others</b>
Number of shares :	<input type="text" value="83800"/>	<input type="text"/>	<input type="text"/>
Amount paid or due and payable on each share			
paid :	<input type="text" value="0.10"/>	<input type="text"/>	<input type="text"/>
due and payable :	<input type="text" value="0"/>	<input type="text"/>	<input type="text"/>
Amount of premium paid or payable on each share :	<input type="text" value="1.50"/>	<input type="text"/>	<input type="text"/>

**Save****Delete Issued Share****Reset****Back**

**Return of Allotment of Shares****Submit**

Please fill in the following information. Fields marked \* must be completed.

<u>Resolution / Declaration</u>	<u>Share payable in cash</u>	<u>For a consideration other than cash</u>	<u>Share Capital / Allottees Particulars</u>	<u>List of Shareholders after the allotment</u>	<u>Summary of Capital</u>
-------------------------------------	----------------------------------	--	--	---	-------------------------------

**Particulars of Allottee**

Please indicate whether the allottee is an Individual : \*

- Allottee is an Individual  
 Allottee is NOT an Individual

If Allottee is an Individual :

Shareholder Category : \* **Individual**Identification No. : \*  **Retrieve Details**Identification Type : \*  ▼Name : \* Nationality : \*  ▼Mobile No : Occupation : Email Address : Address Type : \*  
 Local  
 Foreign

Local Address (\* if Address Type is Local Address)

Postal Code :  **Retrieve Address**Block/House No. :  ▼

Street Name :

Unit : #  - 

Building/Estate Name :

Foreign Address (\* if Address Type is Foreign Address)

Address : 

If Allottee is NOT an Individual :

Shareholder Category : \*  ▼ **Search**

Registration No. : \*

198003912M

Retrieve Details

Name :

**THE CENTRAL DEPOSITORY (PTE) LIMITED**

Address Type :

**Local**

Local Address (\* if Address Type is Local Address)

Postal Code : **068804**

Block/House No. : **2**

Street Name : **SHENTON WAY**

Unit : # **19 - 00**

Building/Estate Name : **SGX CENTRE I**

Foreign Address (\* if Address Type is Foreign Address)

Address :

**Details of Shares Allotted** \* Please read instructions carefully before entering.

Note : If any share or shares is/are co-owned by 2 or more persons, please assign an alphabet e.g. A to denote the Group and enter the same in the box. Enter the same alphabet in the box for every allottee in the same group. Skip this box if share(s) are owned by only one person.

Group of Share that is co-owned:  
(Share Group)

If share(s) is/are co-owned, only one allottee is to enter details in (a), (b), (c), (d) and (e). Enter "0" (zero) for subsequent allottees in box (b) and leave blank for rest of the items.

a) Nominal Value per Share :

0.10

b) No. of shares allotted :

83800

c) Class of shares allotted :

Ordinary

d) Currency :

SINGAPORE DOLLAR (099)

e) Date of allotment :

12/10/2004

(dd/mm/yyyy)

Save

Reset

Back

**Return of Allotment of Shares****Submit**

Please fill in the following information. Fields marked \* must be completed.

<b>Resolution / Declaration</b>	<b>Share payable in cash</b>	<b>For a consideration other than cash</b>	<b>Share Capital / Allottees Particulars</b>	<b>List of Shareholders after Allotment</b>	<b>Summary of Capital</b>
-------------------------------------	----------------------------------	--	--	---	-------------------------------

**List of Allottees and their particulars****Identification****No./Registration Name****Shareholder Category****No.**

198003912M	THE CENTRAL DEPOSITORY (PTE) LIMITED	Company / Foreign Branch
------------	---	--------------------------

If No. of shareholders exceeds 50, total No. of issued shares held by the remaining shareholders are :

<b>No. of Shares</b>	<b>Ordinary</b>	<b>Preference</b>	<b>Others</b>
	0	0	0

**Return of Allotment of Shares****Submit**

Please fill in the following information. Fields marked \* must be completed.

<u>Resolution / Declaration</u>	<u>Share payable in cash</u>	<u>For a consideration other than cash</u>	<u>Share Capital / Allottees Particulars</u>	<u>List of Shareholders after the allotment</u>	<u>Summary of Capital</u>
<b>Share Capital (1)</b>					
Currency :	<b>SINGAPORE DOLLAR (099)</b>				
Nominal Value per Share :	<b>0.10</b>				
Amount of Authorised Share Capital :	<b>200000000.00</b>				
Class of Shares :	Ordinary	Preference	Others		
Amount of Issued Share Capital :	<b>102531257.50</b>	<b>0.00</b>	<b>0.00</b>		
Amount of Paid-up Share Capital :	<b>102531257.50</b>	<b>0.00</b>	<b>0.00</b>		

**RECEIPT**

Receipt No : ACR0000000897673A

Date/Time : 18/10/2004 14:31

Transaction No : C040471970

Agency : RCB - RCB

Application : BIZFILE PAYMENT SERVICE

Paid via : Deposit Service Account

EP Ref No :

**SINGAPORE AIRPORT TERMINAL SERVICES LIMITED**  
**20 AIRPORT BOULEVARD**  
**SATS INFLIGHT CATERING CENTRE 3**  
**SINGAPORE 819659**

Sno	Code/Description	Unit Price (S\$)	Qty	Amount
1	Lodgment Of Return Of Allotment Of Share <b>COMPANY NAME :</b> 197201770G / SINGAPORE AIRPORT TERMINAL SERVICES LIMITED	10.00	1	10.00
Total (S\$) :				10.00

**Deposit Service Account No. : 030066**  
**Balance Amount in Deposit Account : \$ 275.00**

This is a computer-generated receipt. No signature is required.

Please print a copy of the receipt for your reference.

[HOME](#)[LOGOUT](#)



**Return of Allotment of Shares**

Submit

Please fill in the following information. Fields marked \* must be completed.

Resolution/Declaration	Shares payable in cash	For a consideration other than cash	Share Capital/Allottees Particulars	List of Shareholders after the allotment	Summary of Capital
------------------------	---------------------------	---	---	---	-----------------------

**Record saved successfully.****Company Type**

Please click on appropriate button :

- company is listed on the securities exchange  
 company is an unlisted public company  
 company is a private company

**Power under Section 161 of the Companies Act \***

The directors have obtained  
the approval of the company in  Yes ✓  
general meeting to issue  No  
shares.

**Resolution Made**

\* You are only required to fill in this section if the directors are not given the power under Section 161 of the Companies Act to issue shares.

Registration No. : **197201770G**Company Name : **SINGAPORE AIRPORT TERMINAL SERVICES LIMITED**

Nature of Meeting : \* Directors

Place of Meeting : \*

Date of Meeting : \* (dd/mm/yyyy)

Resolution Type : \* Director's

Description : \*  
(max 2000 characters)Attachment : \*  
(copy of resolution)**Note :**

Uploaded file name will be  
changed by suffixing time-  
stamp with the actual file  
name as

filenameyyyyMMddmmsstt

Browse...

(Click 'Browse' to select file for attachment)

Maximum File Size: 20 MB

### Persons signing the resolution

Please indicate the directors/ secretaries who signed the resolution :

- S0036442H / OW CHIN HOCK
- S0070715E / NG KEE CHOE
- S0234645A / CHEW CHOON SENG
- S1001765C / BARRY HENRY PATRICK DESKER
- S1069567H / TAN JIAK NGEE MICHAEL
- S1673157I / YIP WAI PING ANNABELLE
- S1852301I / HONG HAI @ HUANG HAI
- S2163476Z / CHENG WAI WING EDMUND
- S2580327B / RICHARD CHARLES HELFER

Please enter names of other corporate representatives who signed the resolution, if applicable :

### Declaration

I, LIM HONG ENG SUSANNA, Professional body/service bureau, declare the information which has been submitted herein to be true to the best of my knowledge.

**Return of Allotment of Shares**

**Submit**

Please fill in the following information. Fields marked \* must be completed.

Resolution / Declaration	Share payable in cash	For a consideration other than cash	Share Capital / Allottees Particulars	List of Shareholders after the Allotment	Summary of Capital
<b>Authorised Capital</b>					
	Amount		Nominal Value per Share	Currency	
Authorised Capital :	<b>200000000</b>		<b>.1</b>	<b>SINGAPORE DOLLAR ( 099 )</b>	

Description of discrepancy :

**Return of Allotment of Shares (Payable in cash) \***

Applicable only if share is payable in cash

Class of Shares :	Ordinary	Preference	Others
Number of shares :	<input type="text" value="35100"/>	<input type="text"/>	<input type="text"/>
Amount paid or due and payable on each share			
paid :	<input type="text" value="0.10"/>	<input type="text"/>	<input type="text"/>
due and payable :	<input type="text" value="0"/>	<input type="text"/>	<input type="text"/>
Amount of premium paid or payable on each share :	<input type="text" value="1.14"/>	<input type="text"/>	<input type="text"/>

**Save**    **Delete Issued Share**    **Reset**    **Back**

**Return of Allotment of Shares****Submit**

Please fill in the following information. Fields marked \* must be completed.

<u>Resolution / Declaration</u>	<u>Share payable in cash</u>	<u>For a consideration other than cash</u>	<u>Share Capital / Allottees Particulars</u>	<u>List of Shareholders after the allotment</u>	<u>Summary of Capital</u>
---------------------------------	------------------------------	--	--	---	---------------------------

**Particulars of Allottee****Please indicate whether the allottee is an Individual : \***

- Allottee is an Individual  
 Allottee is NOT an Individual

**If Allottee is an Individual :**Shareholder Category : \* **Individual**

Identification No. : \*

**Retrieve Details**

Identification Type : \*

Name : \*

Nationality : \*

Mobile No :

Occupation :

Email Address :

Address Type : \*

- Local  
 Foreign

Local Address (\* if Address Type is Local Address)

Postal Code :

**Retrieve Address**

Block/House No. :

Street Name :

Unit : #

 - 

Building/Estate Name :

Foreign Address (\* if Address Type is Foreign Address)

Address :

**If Allottee is NOT an Individual :**

Shareholder Category : \*

**Search**

Registration No. : \*

198003912M

Retrieve Details

Name : **THE CENTRAL DEPOSITORY (PTE) LIMITED**

Address Type : **Local**

Local Address (\* if Address Type is Local Address)

Postal Code : **068804**

Block/House No. : **2**

Street Name : **SHENTON WAY**

Unit : # **19 - 00**

Building/Estate Name : **SGX CENTRE I**

Foreign Address (\* if Address Type is Foreign Address)

Address :

**Details of Shares Allotted** \* Please read instructions carefully before entering.

Note : If any share or shares is/are co-owned by 2 or more persons, please assign an alphabet e.g. A to denote the Group and enter the same in the box. Enter the same alphabet in the box for every allottee in the same group. Skip this box if share(s) are owned by only one person.

Group of Share that is co-owned:  
(Share Group)

If share(s) is/are co-owned, only one allottee is to enter details in (a), (b), (c), (d) and (e). Enter "0" (zero) for subsequent allottees in box (b) and leave blank for rest of the items.

a) Nominal Value per Share :

b) No. of shares allotted :

c) Class of shares allotted :

d) Currency :

e) Date of allotment :  (dd/mm/yyyy)

**Return of Allotment of Shares**

Please fill in the following information. Fields marked \* must be completed.

<b>Resolution / Declaration</b>	<b>Share payable in cash</b>	<b><u>For a consideration other than cash</u></b>	<b>Share Capital / Allottees Particulars</b>	<b>List of Shareholders after Allotment</b>	<b>Summary of Capital</b>
-------------------------------------	----------------------------------	---	--	---	-------------------------------

**List of Allottees and their particulars****Identification****No./Registration Name  
No.****Shareholder Category**

198003912M	THE CENTRAL DEPOSITORY (PTE) LIMITED	Company / Foreign Branch
------------	---	--------------------------

If No. of shareholders exceeds 50, total No. of issued shares held by the remaining shareholders are :

<b>No. of Shares</b>	<b>Ordinary</b>	<b>Preference</b>	<b>Others</b>
	0	0	0

**Return of Allotment of Shares****Submit**

Please fill in the following information. Fields marked \* must be completed.

<u>Resolution / Declaration</u>	<u>Share payable in cash</u>	<u>For a consideration other than cash</u>	<u>Share Capital / Allottees Particulars</u>	<u>List of Shareholders after the allotment</u>	<u>Summary of Capital</u>
---------------------------------	------------------------------	--	--	---	---------------------------

**Share Capital (1)**

Currency :	<b>SINGAPORE DOLLAR (099)</b>		
Nominal Value per Share :	<b>0.10</b>		
Amount of Authorised Share Capital :	<b>200000000.00</b>		
Class of Shares :	Ordinary	Preference	Others
Amount of Issued Share Capital :	<b>102522877.50</b>	<b>0.00</b>	<b>0.00</b>
Amount of Paid-up Share Capital :	<b>102522877.50</b>	<b>0.00</b>	<b>0.00</b>

**RECEIPT**

Receipt No : ACR0000000897654A

Date/Time : 18/10/2004 14:25

Transaction No : C040471950

Agency : RCB - RCB

Application : BIZFILE PAYMENT SERVICE

Paid via : Deposit Service Account

EP Ref No :

**SINGAPORE AIRPORT TERMINAL SERVICES LIMITED****20 AIRPORT BOULEVARD****SATS INFLIGHT CATERING CENTRE 3****SINGAPORE 819659**

---

<b>Sno Code/Description</b>	<b>Unit Price (S\$)</b>	<b>Qty</b>	<b>Amount</b>
1 Lodgment Of Return Of Allotment Of Share	10.00	1	10.00
<b>COMPANY NAME :</b> 197201770G / SINGAPORE AIRPORT TERMINAL SERVICES LIMITED			
<b>Total (S\$) :</b>			10.00

---

**Deposit Service Account No. : 030066****Balance Amount in Deposit Account : \$ 285.00**

This is a computer-generated receipt. No signature is required.

Please print a copy of the receipt for your reference.

[HOME](#)[LOGOUT](#)



**Return of Allotment of Shares****Submit**

Please fill in the following information. Fields marked \* must be completed.

Resolution/Declaration	Shares payable in cash	For a consideration other than cash	Share Capital/Allottees Particulars	List of Shareholders after the allotment	Summary of Capital
------------------------	---------------------------	---	---	---	-----------------------

**Record saved successfully.****Company Type**

Please click on appropriate button :

- company is listed on the securities exchange ✓  
 company is an unlisted public company  
 company is a private company

**Power under Section 161 of the Companies Act \***

The directors have obtained the approval of the company in general meeting to issue shares.

Yes  
 No ✓

**Resolution Made**

\* You are only required to fill in this section if the directors are not given the power under Section 161 of the Companies Act to issue shares.

Registration No. : **197201770G**Company Name : **SINGAPORE AIRPORT TERMINAL SERVICES LIMITED**Nature of Meeting : \* Directors 

Place of Meeting : \*

Date of Meeting: \* (dd/mm/yyyy)

Resolution Type : \* Director's Description : \*  
(max 2000 characters)Attachment : \*  
(copy of resolution)**Note :**

Uploaded file name will be changed by suffixing time-stamp with the actual file name as

**filenameyyyyMMddmmsstt****Browse...**

(Click 'Browse' to select file for attachment)

**Persons signing the resolution**

Please indicate the directors/ secretaries who signed the resolution :

- S0036442H / OW CHIN HOCK
- S0070715E / NG KEE CHOE
- S0234645A / CHEW CHOON SENG
- S1001765C / BARRY HENRY PATRICK DESKER
- S1069567H / TAN JIAK NGEE MICHAEL
- S1673157I / YIP WAI PING ANNABELLE
- S1852301I / HONG HAI @ HUANG HAI
- S2163476Z / CHENG WAI WING EDMUND
- S2580327B / RICHARD CHARLES HELFER

Please enter names of other corporate representatives who signed the resolution, if applicable :

**Declaration**

I, LIM HONG ENG SUSANNA, Professional body/service bureau, declare the information which has been submitted herein to be true to the best of my knowledge.

**Return of Allotment of Shares**

Submit

Please fill in the following information. Fields marked \* must be completed.

Resolution / Declaration	Share payable in cash	For a consideration other than cash	Share Capital / Allottees Particulars	List of Shareholders after the Allotment	Summary of Capital
--------------------------	-----------------------	-------------------------------------	---------------------------------------	--	--------------------

**Authorised Capital**

	Amount	Nominal Value per Share	Currency
Authorised Capital :	<b>200000000</b>	<b>.1</b>	<b>SINGAPORE DOLLAR ( 099 )</b>

Description of discrepancy :

**Return of Allotment of Shares (Payable in cash) \***

Applicable only if share is payable in cash

Class of Shares :	Ordinary	Preference	Others
Number of shares :	65600		
Amount paid or due and payable on each share			
paid :	0.10		
due and payable :	0		
Amount of premium paid or payable on each share :	1.70		

Save

Delete Issued Share

Reset

Back

**Return of Allotment of Shares****Submit**

Please fill in the following information. Fields marked \* must be completed.

Resolution / Declaration	Share payable in cash	For a consideration other than cash	Share Capital / Allottees / Particulars	List of Shareholders after the allotment	Summary of Capital
-----------------------------	--------------------------	---	---	---	-----------------------

**Particulars of Allottee****Please indicate whether the allottee is an Individual : \***

- Allottee is an Individual  
 Allottee is NOT an Individual

**If Allottee is an Individual :**Shareholder Category : \* **Individual**

Identification No. : \*

**Retrieve Details**

Identification Type : \*

NRIC 

Name : \*

Nationality : \*

Mobile No. :

Occupation :

Email Address :

Address Type : \*

- Local  
 Foreign

Local Address (\* if Address Type is Local Address)

Postal Code :

**Retrieve Address**

Block/House No. :

Street Name :

Unit : #

 - 

Building/Estate Name :

Foreign Address (\* if Address Type is Foreign Address)

Address :

**If Allottee is NOT an Individual :**

Shareholder Category : \*

Company / Foreign Branch **Search**

Registration No. : \*

198003912M

Retrieve Details

Name :

**THE CENTRAL DEPOSITORY (PTE) LIMITED**

Address Type :

**Local**

Local Address (\* if Address Type is Local Address)

Postal Code : **068804**

Block/House No. : **2**

Street Name : **SHENTON WAY**

Unit : # **19 - 00**

Building/Estate Name : **SGX CENTRE I**

Foreign Address (\* if Address Type is Foreign Address)

Address :

**Details of Shares Allotted** \* Please read instructions carefully before entering.

Note : If any share or shares is/are co-owned by 2 or more persons, please assign an alphabet e.g. A to denote the Group and enter the same in the box. Enter the same alphabet in the box for every allottee in the same group. Skip this box if share(s) are owned by only one person.

Group of Share that is co-owned:  
(Share Group)

If share(s) is/are co-owned, only one allottee is to enter details in (a), (b), (c), (d) and (e). Enter "0" (zero) for subsequent allottees in box (b) and leave blank for rest of the items.

a) Nominal Value per Share :

0.10

b) No. of shares allotted :

65600

c) Class of shares allotted :

Ordinary

d) Currency :

SINGAPORE DOLLAR (099)

e) Date of allotment :

12/10/2004

(dd/mm/yyyy)

Save

Reset

Back

**Return of Allotment of Shares****Submit**

Please fill in the following information. Fields marked \* must be completed.

<b>Resolution / Declaration</b>	<b>Share payable in cash</b>	<b>For a consideration other than cash</b>	<b>Share Capital / Allottees Particulars</b>	<b>List of Shareholders after Allotment</b>	<b>Summary of Capital</b>
-------------------------------------	----------------------------------	--	--	---	-------------------------------

**List of Allottees and their particulars****Identification****No./Registration Name  
No.****Shareholder Category**

198003912M	THE CENTRAL DEPOSITORY (PTE) LIMITED	Company / Foreign Branch
------------	---	--------------------------

If No. of shareholders exceeds 50, total No. of issued shares held by the remaining shareholders are :

<b>No. of Shares</b>	<b>Ordinary</b>	<b>Preference</b>	<b>Others</b>
	0	0	0

**Return of Allotment of Shares**[Submit](#)

Please fill in the following information. Fields marked \* must be completed.

<u>Resolution / Declaration</u>	<u>Share payable in cash</u>	<u>For a consideration other than cash</u>	<u>Share Capital / Allottees Particulars</u>	<u>List of Shareholders after the allotment</u>	<u>Summary of Capital</u>
---------------------------------	------------------------------	--	--	---	---------------------------

**Share Capital (1)**

Currency :	<b>SINGAPORE DOLLAR (099)</b>		
Nominal Value per Share :	<b>0.10</b>		
Amount of Authorised Share Capital :	<b>200000000.00</b>		
Class of Shares :	Ordinary	Preference	Others
Amount of Issued Share Capital :	<b>102519367.50</b>	<b>0.00</b>	<b>0.00</b>
Amount of Paid-up Share Capital :	<b>102519367.50</b>	<b>0.00</b>	<b>0.00</b>

GST No. :M9-0008879-T

**RECEIPT**

Receipt No : ACR0000000896948A

Date/Time : 18/10/2004 09:26

Transaction  
No : C040471185

Agency : RCB - RCB

Application : BIZFILE PAYMENT SERVICE

Paid via : Deposit Service Account

EP Ref No :

**SINGAPORE AIRPORT TERMINAL SERVICES LIMITED**  
**20 AIRPORT BOULEVARD**  
**SATS INFLIGHT CATERING CENTRE 3**  
**SINGAPORE 819659**

<b>Sno Code/Description</b>	<b>Unit Price (S\$)</b>	<b>Qty</b>	<b>Amount</b>
1 Lodgment Of Return Of Allotment Of Share <b>COMPANY NAME :</b> 197201770G / SINGAPORE AIRPORT TERMINAL SERVICES LIMITED	10.00	1	10.00
<b>Total (S\$) :</b>			<b>10.00</b>

**Deposit Service Account No. : 030066**  
**Balance Amount in Deposit Account : \$ 295.00**

This is a computer-generated receipt. No signature is required.

Please print a copy of the receipt for your reference.

[HOME](#)[LOGOUT](#)



**LOCAL COMPANY TRANSACTIONS**[HOME](#) [LOGOUT](#)**Return of Allotment of Shares**[Submit](#)

Please fill in the following information. Fields marked \* must be completed.

Resolution/Declaration	Shares payable in cash	For a consideration other than cash	Share Capital/Allottees Particulars	List of Shareholders after the allotment	Summary of Capital
------------------------	------------------------	-------------------------------------	-------------------------------------	--	--------------------

**Record saved successfully.****Company Type**

Please click on appropriate button :

- company is listed on the securities exchange
- company is an unlisted public company
- company is a private company

**Power under Section 161 of the Companies Act \***

The directors have obtained the approval of the company in  Yes  No general meeting to issue shares.

**Resolution Made**

\* You are only required to fill in this section if the directors are not given the power under Section 161 of the Companies Act to issue shares.

Registration No. : **197201770G**Company Name : **SINGAPORE AIRPORT TERMINAL SERVICES LIMITED**Nature of Meeting : \* Place of Meeting : \* Date of Meeting : \*  (dd/mm/yyyy)Resolution Type : \* Description : \* (max 2000 characters) 

Attachment : \* (copy of resolution)

Note :  [Browse...](#)

Uploaded file name will be changed by suffixing time-stamp with the actual file name as **filenameyyyyMMddmmsstt**

(Click 'Browse' to select file for attachment)

**Persons signing the resolution**

Please indicate the directors/ secretaries who signed the resolution :

- S0036442H / OW CHIN HOCK
- S0070715E / NG KEE CHOE
- S0234645A / CHEW CHOON SENG
- S1001765C / BARRY HENRY PATRICK DESKER
- S1069567H / TAN JIAK NGEE MICHAEL
- S1673157I / YIP WAI PING ANNABELLE
- S1852301I / HONG HAI @ HUANG HAI
- S2163476Z / CHENG WAI WING EDMUND
- S2580327B / RICHARD CHARLES HELFER

Please enter names of other corporate representatives who signed the resolution, if applicable :

**Declaration**

I, LIM HONG ENG SUSANNA, Professional body/service bureau, declare the information which has been submitted herein to be true to the best of my knowledge.

**Return of Allotment of Shares****Submit**

Please fill in the following information. Fields marked \* must be completed.

Resolution / Declaration	Share payable in cash	For a consideration other than cash	Share Capital / Allottees Particulars	List of Shareholders after the Allotment	Summary of Capital
--------------------------	-----------------------	-------------------------------------	---------------------------------------	--	--------------------

**Authorised Capital**

	Amount	Nominal Value per Share	Currency
Authorised Capital :	<b>200000000</b>	<b>.1</b>	<b>SINGAPORE DOLLAR ( 099 )</b>

Description of discrepancy :

**Return of Allotment of Shares (Payable in cash) \***

Applicable only if share is payable in cash

Class of Shares :	Ordinary	Preference	Others
Number of shares :	129300 ✓		
Amount paid or due and payable on each share			
paid :	0.10 ✓		
due and payable :	0 ✓		
Amount of premium paid or payable on each share :	1.50		

**Save****Delete Issued Share****Reset****Back**

**Return of Allotment of Shares****Submit**

Please fill in the following information. Fields marked \* must be completed.

Resolution / Declaration	Share payable in cash	For a consideration other than cash	Share Capital / Allottees Particulars	List of Shareholders after the allotment	Summary of Capital
--------------------------	-----------------------	-------------------------------------	---------------------------------------	--	--------------------

**Particulars of Allottee****Please indicate whether the allottee is an Individual : \***

- Allottee is an Individual
- Allottee is NOT an Individual

**If Allottee is an Individual :**Shareholder Category : \* **Individual**Identification No. : \*  **Retrieve Details**Identification Type : \* Name : \* Nationality : \* Mobile No : Occupation : Email Address : Address Type : \*  Local  
 Foreign

Local Address (\* if Address Type is Local Address)

Postal Code :  **Retrieve Address**Block/House No. : Street Name : Unit : #  - Building/Estate Name : 

Foreign Address (\* if Address Type is Foreign Address)

Address :   
**If Allottee is NOT an Individual :**Shareholder Category : \*  **Search**

Name : THE CENTRAL DEPOSITORY (PTE) LIMITED

Address Type : Local

Local Address (\* if Address Type is Local Address)

Postal Code : 068804

Block/House No. : 2

Street Name : SHENTON WAY

Unit : # 19 - 00

Building/Estate Name : SGX CENTRE I

Foreign Address (\* if Address Type is Foreign Address)

Address :

**Details of Shares Allotted** \* Please read instructions carefully before entering.

Note : If any share or shares is/are co-owned by 2 or more persons, please assign an alphabet e.g. A to denote the Group and enter the same in the box. Enter the same alphabet in the box for every allottee in the same group. Skip this box if share(s) are owned by only one person.

Group of Share that is co-owned:  
(Share Group) 

If share(s) is/are co-owned, only one allottee is to enter details in (a), (b), (c), (d) and (e). Enter "0" (zero) for subsequent allottees in box (b) and leave blank for rest of the items.

- a) Nominal Value per Share :
- b) No. of shares allotted :
- c) Class of shares allotted :
- d) Currency :
- e) Date of allotment :  (dd/mm/yyyy)

**Return of Allotment of Shares****Submit**

Please fill in the following information. Fields marked \* must be completed.

<b>Resolution / Declaration</b>	<b>Share payable in cash</b>	<b>For a consideration other than cash</b>	<b>Share Capital / Allottees Particulars</b>	<b>List of Shareholders after Allotment</b>	<b>Summary of Capital</b>
-------------------------------------	----------------------------------	--	--	---	-------------------------------

**List of Allottees and their particulars****Identification****No./Registration Name  
No.****Shareholder Category**

198003912M	THE CENTRAL DEPOSITORY (PTE) LIMITED	Company / Foreign Branch
------------	---	--------------------------

If No. of shareholders exceeds 50, total No. of issued shares held by the remaining shareholders are :

<b>No. of Shares</b>	<b>Ordinary</b>	<b>Preference</b>	<b>Others</b>
	0	0	0

**Return of Allotment of Shares****Submit**

Please fill in the following information. Fields marked \* must be completed.

Resolution / Declaration	Share payable in cash	For a consideration other than cash	Share Capital / Allottees Particulars	List of Shareholders after the allotment	Summary of Capital
--------------------------	-----------------------	-------------------------------------	---------------------------------------	--	--------------------

**Share Capital (1)**

Currency :	<b>SINGAPORE DOLLAR (099)</b>		
Nominal Value per Share :	<b>0.10</b>		
Amount of Authorised Share Capital :	<b>200000000.00</b>		
Class of Shares :	Ordinary	Preference	Others
Amount of Issued Share Capital :	<b>102512807.50</b>	<b>0.00</b>	<b>0.00</b>
Amount of Paid-up Share Capital :	<b>102512807.50</b>	<b>0.00</b>	<b>0.00</b>

**RECEIPT**

Receipt No : ACR0000000896931A

Date/Time : 18/10/2004 09:14

Transaction  
No : C040471165

Agency : RCB - RCB

Application : BIZFILE PAYMENT SERVICE

Paid via : Deposit Service Account

EP Ref No :

**SINGAPORE AIRPORT TERMINAL SERVICES LIMITED****20 AIRPORT BOULEVARD****SATS INFLIGHT CATERING CENTRE 3****SINGAPORE 819659**

---

<b>Sno Code/Description</b>	<b>Unit Price (S\$)</b>	<b>Qty</b>	<b>Amount</b>
1 Lodgment Of Return Of Allotment Of Share <b>COMPANY NAME :</b> 197201770G / SINGAPORE AIRPORT TERMINAL SERVICES LIMITED	10.00	1	10.00
<hr/>			
Total (S\$) :			10.00

---

**Deposit Service Account No. : 030066**  
**Balance Amount in Deposit Account : \$ 305.00**

This is a computer-generated receipt. No signature is required.

Please print a copy of the receipt for your reference.

[HOME](#)[LOGOUT](#)



**Return of Allotment of Shares**

Submit

Please fill in the following information. Fields marked \* must be completed.

Resolution/Declaration	Shares payable in cash	For a consideration other than cash	Share Capital/Allottees Particulars	List of Shareholders after the allotment	Summary of Capital
------------------------	------------------------	-------------------------------------	-------------------------------------	--	--------------------

**Record saved successfully.****Company Type**

Please click on appropriate button :

- company is listed on the securities exchange ✓
- company is an unlisted public company
- company is a private company

**Power under Section 161 of the Companies Act \***

The directors have obtained the approval of the company in  Yes ✓  
 general meeting to issue  No shares.

**Resolution Made**

\* You are only required to fill in this section if the directors are not given the power under Section 161 of the Companies Act to issue shares.

Registration No. : **197201770G**Company Name : **SINGAPORE AIRPORT TERMINAL SERVICES LIMITED**

Nature of Meeting : \* Directors ▼

Place of Meeting : \*

Date of Meeting : \* (dd/mm/yyyy)

Resolution Type : \* Director's ▼

Description : \*  
(max 2000 characters)Attachment : \*  
(copy of resolution)**Note :**

Uploaded file name will be changed by suffixing time-stamp with the actual file name as

**filenameyyyyMMddmmsstt**

Browse...

(Click 'Browse' to select file for attachment)

**Persons signing the resolution**

Please indicate the directors/ secretaries who signed the resolution :

- S0036442H / OW CHIN HOCK
- S0070715E / NG KEE CHOE
- S0234645A / CHEW CHOON SENG
- S1001765C / BARRY HENRY PATRICK DESKER
- S1069567H / TAN JIAK NGEEN MICHAEL
- S1673157I / YIP WAI PING ANNABELLE
- S1852301I / HONG HAI @ HUANG HAI
- S2163476Z / CHENG WAI WING EDMUND
- S2580327B / RICHARD CHARLES HELFER

Please enter names of other corporate representatives who signed the resolution, if applicable :

**Declaration**

I, LIM HONG ENG SUSANNA, Professional body/service bureau, declare the information which has been submitted herein to be true to the best of my knowledge.

**Return of Allotment of Shares**[Submit](#)

Please fill in the following information. Fields marked \* must be completed.

Resolution / Declaration	Share payable in cash	For a consideration other than cash	Share Capital / Allottees Particulars	List of Shareholders after the Allotment	Summary of Capital
--------------------------	-----------------------	-------------------------------------	---------------------------------------	--	--------------------

**Authorised Capital**

	Amount	Nominal Value per Share	Currency
Authorised Capital :	<b>20000000</b>	<b>.1</b>	<b>SINGAPORE DOLLAR ( 099 )</b>

Description of discrepancy :

**Return of Allotment of Shares (Payable in cash) \***

Applicable only if share is payable in cash

Class of Shares :	Ordinary	Preference	Others
Number of shares :	<input type="text" value="32500"/>	<input type="text"/>	<input type="text"/>
Amount paid or due and payable on each share			
paid :	<input type="text" value="0.10"/>	<input type="text"/>	<input type="text"/>
due and payable :	<input type="text" value="0"/>	<input type="text"/>	<input type="text"/>
Amount of premium paid or payable on each share :	<input type="text" value="1.14"/>	<input type="text"/>	<input type="text"/>

<a href="#">Save</a>	<a href="#">Delete Issued Share</a>	<a href="#">Reset</a>	<a href="#">Back</a>
----------------------	-------------------------------------	-----------------------	----------------------

**Return of Allotment of Shares**

Submit

Please fill in the following information. Fields marked \* must be completed.

Resolution / Declaration	Share payable in cash	For a consideration other than cash	Share Capital / Allottees Particulars	List of Shareholders after the allotment	Summary of Capital
--------------------------	-----------------------	-------------------------------------	---------------------------------------	--	--------------------

**Particulars of Allottee**

Please indicate whether the allottee is an Individual : \*

- Allottee is an Individual  
 Allottee is NOT an Individual

If Allottee is an Individual :

Shareholder Category : \* **Individual**

Identification No. : \*

Retrieve Details

Identification Type : \*

NRIC

Name : \*

Nationality : \*

Mobile No :

Occupation :

Email Address :

Address Type : \*

- Local  
 Foreign

Local Address (\* if Address Type is Local Address)

Postal Code :

Retrieve Address

Block/House No. :

Street Name :

Unit : #

 - 

Building/Estate Name :

Foreign Address (\* if Address Type is Foreign Address)

Address :

If Allottee is NOT an Individual :

Shareholder Category : \*

Company / Foreign Branch

Search

Name : THE CENTRAL DEPOSITORY (PTE) LIMITED

Address Type : Local

Local Address (\* if Address Type is Local Address)

Postal Code : 068804

Block/House No. : 2

Street Name : SHENTON WAY

Unit : # 19 - 00

Building/Estate Name : SGX CENTRE I

Foreign Address (\* if Address Type is Foreign Address)

Address :

**Details of Shares Allotted** \* Please read instructions carefully before entering.

Note : If any share or shares is/are co-owned by 2 or more persons, please assign an alphabet e.g. A to denote the Group and enter the same in the box. Enter the same alphabet in the box for every allottee in the same group. Skip this box if share(s) are owned by only one person.

Group of Share that is co-owned:   
(Share Group)

If share(s) is/are co-owned, only one allottee is to enter details in (a), (b), (c), (d) and (e). Enter "0" (zero) for subsequent allottees in box (b) and leave blank for rest of the items.

a) Nominal Value per Share :

b) No. of shares allotted :

c) Class of shares allotted :

d) Currency :

e) Date of allotment :  (dd/mm/yyyy)

**Return of Allotment of Shares****Submit**

Please fill in the following information. Fields marked \* must be completed.

<b>Resolution / Declaration</b>	<b>Share payable in cash</b>	<b>For a consideration other than cash</b>	<b>Share Capital / Allottees Particulars</b>	<b>List of Shareholders after Allotment</b>	<b>Summary of Capital</b>
-------------------------------------	----------------------------------	--	--	---	-------------------------------

**List of Allottees and their particulars****Identification****No./Registration Name  
No.****Shareholder Category**

198003912M	THE CENTRAL DEPOSITORY (PTE) LIMITED	Company / Foreign Branch
------------	---	--------------------------

If No. of shareholders exceeds 50, total No. of issued shares held by the remaining shareholders are :

<b>No. of Shares</b>	<b>Ordinary</b>	<b>Preference</b>	<b>Others</b>
	0	0	0

**Return of Allotment of Shares****Submit**

Please fill in the following information. Fields marked \* must be completed.

Resolution / Declaration	Share payable in cash	For a consideration other than cash	Share Capital / Allottees Particulars	List of Shareholders after the allotment	Summary of Capital
--------------------------	-----------------------	-------------------------------------	---------------------------------------	--	--------------------

**Share Capital (1)**

Currency :	<b>SINGAPORE DOLLAR (099)</b>		
Nominal Value per Share :	<b>0.10</b>		
Amount of Authorised Share Capital :	<b>200000000.00</b>		
Class of Shares :	Ordinary	Preference	Others
Amount of Issued Share Capital :	<b>102499877.50</b>	<b>0.00</b>	<b>0.00</b>
Amount of Paid-up Share Capital :	<b>102499877.50</b>	<b>0.00</b>	<b>0.00</b>

GST No. :M9-0008879-T

**RECEIPT**

Receipt No : ACR0000000896925A

Date/Time : 18/10/2004 09:02

Transaction  
No : C040471154

Agency : RCB - RCB

Application : BIZFILE PAYMENT SERVICE

Paid via : Deposit Service Account

EP Ref No :

**SINGAPORE AIRPORT TERMINAL SERVICES LIMITED  
20 AIRPORT BOULEVARD  
SATS INFLIGHT CATERING CENTRE 3  
SINGAPORE 819659**

<b>Sno Code/Description</b>	<b>Unit Price (S\$)</b>	<b>Qty</b>	<b>Amount</b>
1 Lodgment Of Return Of Allotment Of Share <b>COMPANY NAME :</b> 197201770G / SINGAPORE AIRPORT TERMINAL SERVICES LIMITED	10.00	1	10.00
<b>Total (S\$) :</b>			<b>10.00</b>

**Deposit Service Account No. : 030066  
Balance Amount in Deposit Account : \$ 315.00**

This is a computer-generated receipt. No signature is required.

Please print a copy of the receipt for your reference.

[HOME](#)[LOGOUT](#)



**Return of Allotment of Shares****Submit**

Please fill in the following information. Fields marked \* must be completed.

Resolution/Declaration	Shares payable in cash	For a consideration other than cash	Share Capital/Allottees Particulars	List of Shareholders after the allotment	Summary of Capital
------------------------	------------------------	-------------------------------------	-------------------------------------	--	--------------------

**Record saved successfully.****Company Type**

Please click on appropriate button :

- company is listed on the securities exchange  
 company is an unlisted public company  
 company is a private company

**Power under Section 161 of the Companies Act \***

The directors have obtained the approval of the company in  Yes  No general meeting to issue shares.

**Resolution Made**

\* You are only required to fill in this section if the directors are not given the power under Section 161 of the Companies Act to issue shares.

Registration No. : **197201770G**Company Name : **SINGAPORE AIRPORT TERMINAL SERVICES LIMITED**Nature of Meeting : \* **Directors**

Place of Meeting : \*

Date of Meeting : \* (dd/mm/yyyy)

Resolution Type : \* **Director's**Description : \*  
(max 2000 characters)Attachment : \*  
(copy of resolution)**Note :**

Uploaded file name will be changed by suffixing time-stamp with the actual file name as

filenameyyyyMMddmmsstt

**Browse...**

(Click 'Browse' to select file for attachment)

**Persons signing the resolution**

Please indicate the directors/ secretaries who signed the resolution :

- S0036442H / OW CHIN HOCK
- S0070715E / NG KEE CHOE
- S0234645A / CHEW CHOON SENG
- S1001765C / BARRY HENRY PATRICK DESKER
- S1069567H / TAN JIAK NGEE MICHAEL
- S1673157I / YIP WAI PING ANNABELLE
- S1852301I / HONG HAI @ HUANG HAI
- S2163476Z / CHENG WAI WING EDMUND
- S2580327B / RICHARD CHARLES HELFER

Please enter names of other corporate representatives who signed the resolution, if applicable :

**Declaration**

I, LIM HONG ENG SUSANNA, Professional body/service bureau, declare the information which has been submitted herein to be true to the best of my knowledge.

**Return of Allotment of Shares**

[Submit](#)

Please fill in the following information. Fields marked \* must be completed.

Resolution / Declaration	Share payable in cash	For a consideration other than cash	Share Capital / Allottees Particulars	List of Shareholders after the Allotment	Summary of Capital
--------------------------	-----------------------	-------------------------------------	---------------------------------------	--	--------------------

**Authorised Capital**

	Amount	Nominal Value per Share	Currency
Authorised Capital :	<b>200000000</b>	<b>.1</b>	<b>SINGAPORE DOLLAR ( 099 )</b>

Description of discrepancy :

**Return of Allotment of Shares (Payable in cash) \***

Applicable only if share is payable in cash

Class of Shares :	Ordinary	Preference	Others
Number of shares :	<input type="text" value="70800"/>	<input type="text"/>	<input type="text"/>
Amount paid or due and payable on each share			
paid :	<input type="text" value="0.10"/>	<input type="text"/>	<input type="text"/>
due and payable :	<input type="text" value="0"/>	<input type="text"/>	<input type="text"/>
Amount of premium paid or payable on each share :	<input type="text" value="1.70"/>	<input type="text"/>	<input type="text"/>

[Save](#)   [Delete Issued Share](#)   [Reset](#)   [Back](#)

**Return of Allotment of Shares**

Submit

Please fill in the following information. Fields marked \* must be completed.

Resolution / Declaration	Share payable in cash	For a consideration other than cash	Share Capital / Allottees Particulars	List of Shareholders after the allotment	Summary of Capital
--------------------------	-----------------------	-------------------------------------	---------------------------------------	--	--------------------

**Particulars of Allottee**

Please indicate whether the allottee is an Individual : \*

- Allottee is an Individual  
 Allottee is NOT an Individual

If Allottee is an Individual :

Shareholder Category : \* **Individual**

Identification No. : \*

Retrieve Details

Identification Type : \*

Name : \*

Nationality : \*

Mobile No :

Occupation :

Email Address :

Address Type : \*

- Local  
 Foreign

Local Address (\* if Address Type is Local Address)

Postal Code :

Retrieve Address

Block/House No. :

Street Name :

Unit : #

 - 

Building/Estate Name :

Foreign Address (\* if Address Type is Foreign Address)

Address :

If Allottee is NOT an Individual :

Shareholder Category : \*

Search

Name : **THE CENTRAL DEPOSITORY (PTE) LIMITED**Address Type : **Local**

Local Address (\* if Address Type is Local Address)

Postal Code : **068804**Block/House No. : **2**Street Name : **SHENTON WAY**Unit : # **19 - 00**Building/Estate Name : **SGX CENTRE I**

Foreign Address (\* if Address Type is Foreign Address)

Address :

**Details of Shares Allotted** \* Please read instructions carefully before entering.

Note : If any share or shares is/are co-owned by 2 or more persons, please assign an alphabet e.g. A to denote the Group and enter the same in the box. Enter the same alphabet in the box for every allottee in the same group. Skip this box if share(s) are owned by only one person.

Group of Share that is co-owned:  
(Share Group) 

If share(s) is/are co-owned, only one allottee is to enter details in (a), (b), (c), (d) and (e). Enter "0" (zero) for subsequent allottees in box (b) and leave blank for rest of the items.

- a) Nominal Value per Share :
- b) No. of shares allotted :
- c) Class of shares allotted :
- d) Currency :
- e) Date of allotment :  (dd/mm/yyyy) ✓

**Return of Allotment of Shares****Submit**

Please fill in the following information. Fields marked \* must be completed.

<b>Resolution / Declaration</b>	<b>Share payable in cash</b>	<b>For a consideration other than cash</b>	<b>Share Capital / Allottees Particulars</b>	<b>List of Shareholders after Allotment</b>	<b>Summary of Capital</b>
-------------------------------------	----------------------------------	--	--	---	-------------------------------

**List of Allottees and their particulars****Identification****No./Registration Name  
No.****Shareholder Category**

198003912M	THE CENTRAL DEPOSITORY (PTE) LIMITED	Company / Foreign Branch
------------	---	--------------------------

If No. of shareholders exceeds 50, total No. of issued shares held by the remaining shareholders are :

	<b>Ordinary</b>	<b>Preference</b>	<b>Others</b>
<b>No. of Shares</b>	<b>0</b>	<b>0</b>	<b>0</b>

**Return of Allotment of Shares****Submit**

Please fill in the following information. Fields marked \* must be completed.

Resolution / Declaration	Share payable in cash	For a consideration other than cash	Share Capital / Allottees Particulars	List of Shareholders after the allotment	Summary of Capital
--------------------------	-----------------------	-------------------------------------	---------------------------------------	--	--------------------

**Share Capital (1)**

Currency :	<b>SINGAPORE DOLLAR (099)</b>		
Nominal Value per Share :	<b>0.10</b>		
Amount of Authorised Share Capital :	<b>200000000.00</b>		
Class of Shares :	Ordinary	Preference	Others
Amount of Issued Share Capital :	<b>102496627.50</b>	<b>0.00</b>	<b>0.00</b>
Amount of Paid-up Share Capital :	<b>102496627.50</b>	<b>0.00</b>	<b>0.00</b>

GST No. :M9-0008879-T

**RECEIPT**

Receipt No : ACR0000000893115A

Date/Time : 14/10/2004 10:43

Transaction  
No : C040466948

Agency : RCB - RCB

Application : BIZFILE PAYMENT SERVICE

Paid via : Deposit Service Account

EP Ref No :

**SINGAPORE AIRPORT TERMINAL SERVICES LIMITED  
20 AIRPORT BOULEVARD  
SATS INFLIGHT CATERING CENTRE 3  
SINGAPORE 819659**

<b>Sno Code/Description</b>	<b>Unit Price (S\$)</b>	<b>Qty</b>	<b>Amount</b>
1 Lodgment Of Return Of Allotment Of Share <b>COMPANY NAME :</b> 197201770G / SINGAPORE AIRPORT TERMINAL SERVICES LIMITED	10.00	1	10.00
<b>Total (S\$) :</b>			<b>10.00</b>

**Deposit Service Account No. : 030066**  
**Balance Amount in Deposit Account : \$ 325.00**

This is a computer-generated receipt. No signature is required.

Please print a copy of the receipt for your reference.

[HOME](#)[LOGOUT](#)



**Return of Allotment of Shares****Submit**

Please fill in the following information. Fields marked \* must be completed.

Resolution/Declaration	Shares payable in cash	For a consideration other than cash	Share Capital/Allottees Particulars	List of Shareholders after the allotment	Summary of Capital
------------------------	---------------------------	---	---	---	-----------------------

**Record saved successfully.****Company Type**

Please click on appropriate button :

- company is listed on the securities exchange  
 company is an unlisted public company  
 company is a private company

**Power under Section 161 of the Companies Act \***

The directors have obtained the approval of the company in  Yes  No general meeting to issue shares.

**Resolution Made**

\* You are only required to fill in this section if the directors are not given the power under Section 161 of the Companies Act to issue shares.

Registration No. : **197201770G**Company Name : **SINGAPORE AIRPORT TERMINAL SERVICES LIMITED**Nature of Meeting : \* 

Place of Meeting : \*

Date of Meeting : \*  (dd/mm/yyyy)Resolution Type : \* Description : \*  
(max 2000 characters)Attachment : \*  
(copy of resolution)**Note :**

Uploaded file name will be changed by suffixing time-stamp with the actual file name as

filenameyyyyMMddmmsstt

**Browse...**

(Click 'Browse' to select file for attachment)

**Persons signing the resolution**

Please indicate the directors/ secretaries who signed the resolution :

- S0036442H / OW CHIN HOCK
- S0070715E / NG KEE CHOE
- S0234645A / CHEW CHOON SENG
- S1001765C / BARRY HENRY PATRICK DESKER
- S1069567H / TAN JIAK NGEN MICHAEL
- S1673157I / YIP WAI PING ANNABELLE
- S1852301I / HONG HAI @ HUANG HAI
- S2163476Z / CHENG WAI WING EDMUND
- S2580327B / RICHARD CHARLES HELFER

Please enter names of other corporate representatives who signed the resolution, if applicable :

**Declaration**

I, LIM HONG ENG SUSANNA, Professional body/service bureau, declare the information which has been submitted herein to be true to the best of my knowledge.

**Return of Allotment of Shares****Submit**

Please fill in the following information. Fields marked \* must be completed.

Resolution / Declaration	Share payable in cash	For a consideration other than cash	Share Capital / Allottees Particulars	List of Shareholders after the Allotment	Summary of Capital
--------------------------	-----------------------	-------------------------------------	---------------------------------------	--	--------------------

**Authorised Capital**

	Amount	Nominal Value per Share	Currency
Authorised Capital :	<b>200000000</b>	<b>.1</b>	<b>SINGAPORE DOLLAR ( 099 )</b>

Description of discrepancy :

**Return of Allotment of Shares (Payable in cash) \***

Applicable only if share is payable in cash

Class of Shares :	Ordinary	Preference	Others
Number of shares :	<input type="text" value="98400"/>	<input type="text"/>	<input type="text"/>
Amount paid or due and payable on each share			
paid :	<input type="text" value="0.10"/>	<input type="text"/>	<input type="text"/>
due and payable :	<input type="text" value="0"/>	<input type="text"/>	<input type="text"/>
Amount of premium paid or payable on each share :	<input type="text" value="1.50"/>	<input type="text"/>	<input type="text"/>

**Save****Delete Issued Share****Reset****Back**

**Return of Allotment of Shares**

Submit

Please fill in the following information. Fields marked \* must be completed.

Resolution / Declaration	Share payable in cash	For a consideration other than cash	Share Capital / Allottees Particulars	List of Shareholders after the allotment	Summary of Capital
--------------------------	-----------------------	-------------------------------------	---------------------------------------	--	--------------------

**Particulars of Allottee**

Please indicate whether the allottee is an Individual : \*

- Allottee is an Individual  
 Allottee is NOT an Individual

If Allottee is an Individual :

Shareholder Category : \* **Individual**

Identification No. : \*

Retrieve Details

Identification Type : \*

NRIC

Name : \*

Nationality : \*

Mobile No :

Occupation :

Email Address :

Address Type : \*

- Local  
 Foreign

Local Address (\* if Address Type is Local Address)

Postal Code :

Retrieve Address

Block/House No. :

Street Name :

Unit : #

 - 

Building/Estate Name :

Foreign Address (\* if Address Type is Foreign Address)

Address :

If Allottee is NOT an Individual :

Shareholder Category : \*

Company / Foreign Branch

Search

Registration No. : \*

198003912M

Retrieve Details

Name :

**THE CENTRAL DEPOSITORY (PTE) LIMITED**

Address Type :

**Local**

Local Address (\* if Address Type is Local Address)

Postal Code : **068804**

Block/House No. : **2**

Street Name : **SHENTON WAY**

Unit : # **19 - 00**

Building/Estate Name : **SGX CENTRE I**

Foreign Address (\* if Address Type is Foreign Address)

Address :

**Details of Shares Allotted** \* Please read instructions carefully before entering.

Note : If any share or shares is/are co-owned by 2 or more persons, please assign an alphabet e.g. A to denote the Group and enter the same in the box. Enter the same alphabet in the box for every allottee in the same group. Skip this box if share(s) are owned by only one person.

Group of Share that is co-owned:  
(Share Group)

If share(s) is/are co-owned, only one allottee is to enter details in (a), (b), (c), (d) and (e). Enter "0" (zero) for subsequent allottees in box (b) and leave blank for rest of the items.

a) Nominal Value per Share :

0.10

b) No. of shares allotted :

98400

c) Class of shares allotted :

Ordinary

d) Currency :

SINGAPORE DOLLAR (099)

e) Date of allotment :

08/10/2004 (dd/mm/yyyy)

Save

Reset

Back

**Return of Allotment of Shares****Submit**

Please fill in the following information. Fields marked \* must be completed.

<b>Resolution / Declaration</b>	<b>Share payable in cash</b>	<b>For a consideration other than cash</b>	<b>Share Capital / Allottees Particulars</b>	<b>List of Shareholders after Allotment</b>	<b>Summary of Capital</b>
-------------------------------------	----------------------------------	--	--	---	-------------------------------

**List of Allottees and their particulars****Identification****No./Registration Name  
No.****Shareholder Category**

198003912M	THE CENTRAL DEPOSITORY (PTE) LIMITED	Company / Foreign Branch
------------	---	--------------------------

If No. of shareholders exceeds 50, total No. of issued shares held by the remaining shareholders are :

	<b>Ordinary</b>	<b>Preference</b>	<b>Others</b>
<b>No. of Shares</b>	0	0	0

**Return of Allotment of Shares****Submit**

Please fill in the following information. Fields marked \* must be completed.

<u>Resolution / Declaration</u>	<u>Share payable in cash</u>	<u>For a consideration other than cash</u>	<u>Share Capital / Allottees Particulars</u>	<u>List of Shareholders after the allotment</u>	<u>Summary of Capital</u>
<b>Share Capital (1)</b>					
Currency :	<b>SINGAPORE DOLLAR (099)</b>				
Nominal Value per Share :	<b>0.10</b>				
Amount of Authorised Share Capital :	<b>200000000.00</b>				
Class of Shares :	Ordinary	Preference	Others		
Amount of Issued Share Capital :	<b>102489547.50</b>	<b>0.00</b>	<b>0.00</b>		
Amount of Paid-up Share Capital :	<b>102489547.50</b>	<b>0.00</b>	<b>0.00</b>		

GST No. :M9-0008879-T

**RECEIPT**

Receipt No : ACR0000000893093A

Date/Time : 14/10/2004 10:37

Transaction No : C040466925

Agency : RCB - RCB

Application : BIZFILE PAYMENT SERVICE

Paid via : Deposit Service Account

EP Ref No :

**SINGAPORE AIRPORT TERMINAL SERVICES LIMITED****20 AIRPORT BOULEVARD****SATS INFLIGHT CATERING CENTRE 3****SINGAPORE 819659**

---

<b>Sno Code/Description</b>	<b>Unit Price (S\$)</b>	<b>Qty</b>	<b>Amount</b>
1 Lodgment Of Return Of Allotment Of Share <b>COMPANY NAME :</b> 197201770G / SINGAPORE AIRPORT TERMINAL SERVICES LIMITED	10.00	1	10.00
<hr/>			
Total (S\$) :			10.00

---

**Deposit Service Account No. : 030066****Balance Amount in Deposit Account : \$ 335.00**

This is a computer-generated receipt. No signature is required.

Please print a copy of the receipt for your reference.

[HOME](#)[LOGOUT](#)



**Return of Allotment of Shares****Submit**

Please fill in the following information. Fields marked \* must be completed.

Resolution/Declaration	Shares payable in cash	For a consideration other than cash	Share Capital/Allottees Particulars	List of Shareholders after the allotment	Summary of Capital
------------------------	---------------------------	---	---	---	-----------------------

**Record saved successfully.****Company Type**

Please click on appropriate button :

- company is listed on the securities exchange  
 company is an unlisted public company  
 company is a private company

**Power under Section 161 of the Companies Act \***

The directors have obtained the approval of the company in  Yes  No general meeting to issue shares.

**Resolution Made**

\* You are only required to fill in this section if the directors are not given the power under Section 161 of the Companies Act to issue shares.

Registration No. : **197201770G**Company Name : **SINGAPORE AIRPORT TERMINAL SERVICES LIMITED**Nature of Meeting : \*  ▼

Place of Meeting : \*

Date of Meeting : \*  (dd/mm/yyyy)Resolution Type : \*  ▼Description : \*  
(max 2000 characters)
Attachment : \*  
(copy of resolution)**Note :**

Uploaded file name will be changed by suffixing time-stamp with the actual file name as

**filenameyyyyMMddmmsstt**
 **Browse...**

(Click 'Browse' to select file for attachment)

**Persons signing the resolution**

Please indicate the directors/ secretaries who signed the resolution :

- S0036442H / OW CHIN HOCK
- S0070715E / NG KEE CHOE
- S0234645A / CHEW CHOON SENG
- S1001765C / BARRY HENRY PATRICK DESKER
- S1069567H / TAN JIAK NGEE MICHAEL
- S1673157I / YIP WAI PING ANNABELLE
- S1852301I / HONG HAI @ HUANG HAI
- S2163476Z / CHENG WAI WING EDMUND
- S2580327B / RICHARD CHARLES HELFER

Please enter names of other corporate representatives who signed the resolution, if applicable :

**Declaration**

I, LIM HONG ENG SUSANNA, Professional body/service bureau, declare the information which has been submitted herein to be true to the best of my knowledge.

**Return of Allotment of Shares****Submit**

Please fill in the following information. Fields marked \* must be completed.

Resolution / Declaration	Share payable in cash	For a consideration other than cash	Share Capital / Allottees Particulars	List of Shareholders after the Allotment	Summary of Capital
--------------------------	-----------------------	-------------------------------------	---------------------------------------	--	--------------------

**Authorised Capital**

	Amount	Nominal Value per Share	Currency
Authorised Capital :	<b>200000000</b>	<b>.1</b>	<b>SINGAPORE DOLLAR ( 099 )</b>

Description of discrepancy :

**Return of Allotment of Shares (Payable in cash) \***

Applicable only if share is payable in cash

Class of Shares :	Ordinary	Preference	Others
Number of shares :	<input type="text" value="28200"/>	<input type="text"/>	<input type="text"/>
Amount paid or due and payable on each share			
paid :	<input type="text" value="0.10"/>	<input type="text"/>	<input type="text"/>
due and payable :	<input type="text" value="0"/>	<input type="text"/>	<input type="text"/>
Amount of premium paid or payable on each share :	<input type="text" value="1.14"/>	<input type="text"/>	<input type="text"/>

**Save****Delete Issued Share****Reset****Back**

**Return of Allotment of Shares****Submit**

Please fill in the following information. Fields marked \* must be completed.

Resolution / Declaration	Share payable in cash	For a consideration other than cash	Share Capital / Allottees Particulars	List of Shareholders after the allotment	Summary of Capital
--------------------------	-----------------------	-------------------------------------	---------------------------------------	--	--------------------

**Particulars of Allottee**

Please indicate whether the allottee is an Individual : \*

- Allottee is an Individual  
 Allottee is NOT an Individual

If Allottee is an Individual :

Shareholder Category : \* **Individual**Identification No. : \*  **Retrieve Details**Identification Type : \* Name : \* Nationality : \* Mobile No : Occupation : Email Address : Address Type : \*  
 Local  
 Foreign

Local Address (\* if Address Type is Local Address)

Postal Code :  **Retrieve Address**Block/House No. : Street Name : Unit : #  - Building/Estate Name : 

Foreign Address (\* if Address Type is Foreign Address)

Address : 

If Allottee is NOT an Individual :

Shareholder Category : \*  **Search**

Registration No. : \*

Name : **THE CENTRAL DEPOSITORY (PTE) LIMITED**

Address Type : **Local**

Local Address (\* if Address Type is Local Address)

Postal Code : **068804**

Block/House No. : **2**

Street Name : **SHENTON WAY**

Unit : # **19 - 00**

Building/Estate Name : **SGX CENTRE I**

Foreign Address (\* if Address Type is Foreign Address)

Address :

**Details of Shares Allotted** \* Please read instructions carefully before entering.

Note : If any share or shares is/are co-owned by 2 or more persons, please assign an alphabet e.g. A to denote the Group and enter the same in the box. Enter the same alphabet in the box for every allottee in the same group. Skip this box if share(s) are owned by only one person.

Group of Share that is co-owned:  
(Share Group)

If share(s) is/are co-owned, only one allottee is to enter details in (a), (b), (c), (d) and (e). Enter "0" (zero) for subsequent allottees in box (b) and leave blank for rest of the items.

- a) Nominal Value per Share :
- b) No. of shares allotted :
- c) Class of shares allotted :
- d) Currency :
- e) Date of allotment :  (dd/mm/yyyy)

**Return of Allotment of Shares****Submit**

Please fill in the following information. Fields marked \* must be completed.

<b>Resolution / Declaration</b>	<b>Share payable in cash</b>	<b>For a consideration other than cash</b>	<b>Share Capital / Allottees Particulars</b>	<b>List of Shareholders after Allotment</b>	<b>Summary of Capital</b>
-------------------------------------	----------------------------------	--	--	---	-------------------------------

**List of Allottees and their particulars****Identification****No./Registration Name  
No.****Shareholder Category**

198003912M	THE CENTRAL DEPOSITORY (PTE) LIMITED	Company / Foreign Branch
------------	---	--------------------------

If No. of shareholders exceeds 50, total No. of issued shares held by the remaining shareholders are :

	<b>Ordinary</b>	<b>Preference</b>	<b>Others</b>
<b>No. of Shares</b>	<b>0</b>	<b>0</b>	<b>0</b>

**Return of Allotment of Shares****Submit**

Please fill in the following information. Fields marked \* must be completed.

Resolution / Declaration	Share payable in cash	For a consideration other than cash	Share Capital / Allottees Particulars	List of Shareholders after the allotment	Summary of Capital
<b>Share Capital (1)</b>					
Currency :	<b>SINGAPORE DOLLAR (099)</b>				
Nominal Value per Share :	<b>0.10</b>				
Amount of Authorised Share Capital :	<b>200000000.00</b>				
Class of Shares :	Ordinary	Preference	Others		
Amount of Issued Share Capital :	<b>102479707.50</b>	<b>0.00</b>	<b>0.00</b>		
Amount of Paid-up Share Capital :	<b>102479707.50</b>	<b>0.00</b>	<b>0.00</b>		

**RECEIPT**

Receipt No : ACR0000000893073A

Date/Time : 14/10/2004 10:31

Transaction  
No : C040466899

Agency : RCB - RCB

Application : BIZFILE PAYMENT SERVICE

Paid via : Deposit Service Account

EP Ref No :

**SINGAPORE AIRPORT TERMINAL SERVICES LIMITED**  
**20 AIRPORT BOULEVARD**  
**SATS INFLIGHT CATERING CENTRE 3**  
**SINGAPORE 819659**

<b>Sno Code/Description</b>	<b>Unit Price (S\$)</b>	<b>Qty</b>	<b>Amount</b>
1 Lodgment Of Return Of Allotment Of Share <b>COMPANY NAME :</b> 197201770G / SINGAPORE AIRPORT TERMINAL SERVICES LIMITED	10.00	1	10.00
<b>Total (S\$) :</b>			<b>10.00</b>

**Deposit Service Account No. : 030066**  
**Balance Amount in Deposit Account : \$ 345.00**

This is a computer-generated receipt. No signature is required.

Please print a copy of the receipt for your reference.

[HOME](#)[LOGOUT](#)



**LOCAL COMPANY TRANSACTIONS**[HOME](#) [LOGOUT](#)**Return of Allotment of Shares**[Submit](#)

Please fill in the following information. Fields marked \* must be completed.

Resolution/Declaration	Shares payable in cash	For a consideration other than cash	Share Capital/Allottees Particulars	List of Shareholders after the allotment	Summary of Capital
------------------------	------------------------	-------------------------------------	-------------------------------------	--	--------------------

**Record saved successfully.****Company Type**

Please click on appropriate button :

- company is listed on the securities exchange
- company is an unlisted public company
- company is a private company

**Power under Section 161 of the Companies Act \***

The directors have obtained the approval of the company in  Yes  No shares.

**Resolution Made**

\* You are only required to fill in this section if the directors are not given the power under Section 161 of the Companies Act to issue shares.

Registration No. : **197201770G**Company Name : **SINGAPORE AIRPORT TERMINAL SERVICES LIMITED**Nature of Meeting : \*  ▼Place of Meeting : \* Date of Meeting : \*  (dd/mm/yyyy)Resolution Type : \*  ▼Description : \*   
(max 2000 characters)Attachment : \*  
(copy of resolution)**Note :**  [Browse...](#)

Uploaded file name will be changed by suffixing time-stamp with the actual file name as  
**filenameyyyyMMddmmsstt**

(Click 'Browse' to select file for attachment)

### Persons signing the resolution

Please indicate the directors/ secretaries who signed the resolution :

- S0036442H / OW CHIN HOCK
- S0070715E / NG KEE CHOE
- S0234645A / CHEW CHOON SENG
- S1001765C / BARRY HENRY PATRICK DESKER
- S1069567H / TAN JIAK NGEE MICHAEL
- S1673157I / YIP WAI PING ANNABELLE
- S1852301I / HONG HAI @ HUANG HAI
- S2163476Z / CHENG WAI WING EDMUND
- S2580327B / RICHARD CHARLES HELFER

Please enter names of other corporate representatives who signed the resolution, if applicable :

### Declaration

I, LIM HONG ENG SUSANNA, Professional body/service bureau, declare the information which has been submitted herein to be true to the best of my knowledge.

**Return of Allotment of Shares****Submit**

Please fill in the following information. Fields marked \* must be completed.

Resolution / Declaration	Share payable in cash	For a consideration other than cash	Share Capital / Allottees Particulars	List of Shareholders after the Allotment	Summary of Capital
--------------------------	-----------------------	-------------------------------------	---------------------------------------	--	--------------------

**Authorised Capital**

	Amount	Nominal Value per Share	Currency
Authorised Capital :	<b>20000000</b>	<b>.1</b>	<b>SINGAPORE DOLLAR ( 099 )</b>

Description of discrepancy :

**Return of Allotment of Shares (Payable in cash) \***

Applicable only if share is payable in cash

Class of Shares :	Ordinary	Preference	Others
Number of shares :	7800 ✓		
Amount paid or due and payable on each share			
paid :	0.10		
due and payable :	0		
Amount of premium paid or payable on each share :	1.70		

**Save****Delete Issued Share****Reset****Back**

**Return of Allotment of Shares**

Submit

Please fill in the following information. Fields marked \* must be completed.

Resolution / Declaration	Share payable in cash	For a consideration other than cash	Share Capital / Allottees Particulars	List of Shareholders after the allotment	Summary of Capital
-----------------------------	--------------------------	---	---	---	-----------------------

**Particulars of Allottee**

Please indicate whether the allottee is an Individual : \*

- Allottee is an Individual  
 Allottee is NOT an Individual

If Allottee is an Individual :

Shareholder Category : \* **Individual**Identification No. : \*  Retrieve DetailsIdentification Type : \* Name : \* Nationality : \* Mobile No : Occupation : Email Address : Address Type : \*  
 Local  
 Foreign

Local Address (\* if Address Type is Local Address)

Postal Code :  Retrieve AddressBlock/House No. : 

Street Name :

Unit : #  - 

Building/Estate Name :

Foreign Address (\* if Address Type is Foreign Address)

Address : 

If Allottee is NOT an Individual :

Shareholder Category : \*  Search

Registration No. : \*

198003912M

Retrieve Details

Name :

**THE CENTRAL DEPOSITORY (PTE) LIMITED**

Address Type :

**Local**

Local Address (\* if Address Type is Local Address)

Postal Code : **068804**

Block/House No. : **2**

Street Name : **SHENTON WAY**

Unit : # **19 - 00**

Building/Estate Name : **SGX CENTRE I**

Foreign Address (\* if Address Type is Foreign Address)

Address :

**Details of Shares Allotted** \* Please read instructions carefully before entering.

Note : If any share or shares is/are co-owned by 2 or more persons, please assign an alphabet e.g. A to denote the Group and enter the same in the box. Enter the same alphabet in the box for every allottee in the same group. Skip this box if share(s) are owned by only one person.

Group of Share that is co-owned:  
(Share Group)

If share(s) is/are co-owned, only one allottee is to enter details in (a), (b), (c), (d) and (e). Enter "0" (zero) for subsequent allottees in box (b) and leave blank for rest of the items.

a) Nominal Value per Share :

0.10

b) No. of shares allotted :

7800

c) Class of shares allotted :

Ordinary

d) Currency :

SINGAPORE DOLLAR (099)

e) Date of allotment :

08/10/2004 (dd/mm/yyyy)

Save

Reset

Back

**Return of Allotment of Shares****Submit**

Please fill in the following information. Fields marked \* must be completed.

<b>Resolution / Declaration</b>	<b>Share payable in cash</b>	<b>For a consideration other than cash</b>	<b>Share Capital / Allottees Particulars</b>	<b>List of Shareholders after Allotment</b>	<b>Summary of Capital</b>
-------------------------------------	----------------------------------	--	--	---	-------------------------------

**List of Allottees and their particulars****Identification****No./Registration Name  
No.****Shareholder Category**

198003912M	THE CENTRAL DEPOSITORY (PTE) LIMITED	Company / Foreign Branch
------------	---	--------------------------

If No. of shareholders exceeds 50, total No. of issued shares held by the remaining shareholders are :

	<b>Ordinary</b>	<b>Preference</b>	<b>Others</b>
<b>No. of Shares</b>	<b>0</b>	<b>0</b>	<b>0</b>

**Return of Allotment of Shares**

Submit

Please fill in the following information. Fields marked \* must be completed.

<u>Resolution / Declaration</u>	<u>Share payable in cash</u>	<u>For a consideration other than cash</u>	<u>Share Capital / Allottees Particulars</u>	<u>List of Shareholders after the allotment</u>	<u>Summary of Capital</u>
---------------------------------	------------------------------	--	--	---	---------------------------

**Share Capital (1)**

Currency :	<b>SINGAPORE DOLLAR (099)</b>				
Nominal Value per Share :	<b>0.10</b>				
Amount of Authorised Share Capital :	<b>200000000.00</b>				
Class of Shares :	Ordinary	Preference	Others		
Amount of Issued Share Capital :	<b>102476887.50</b>	<b>0.00</b>	<b>0.00</b>		
Amount of Paid-up Share Capital :	<b>102476887.50</b>	<b>0.00</b>	<b>0.00</b>		

**RECEIPT**

Receipt No : ACR0000000891161A

Date/Time : 13/10/2004 10:56

Transaction No : C040464842

Agency : RCB - RCB

Application : BIZFILE PAYMENT SERVICE

Paid via : Deposit Service Account

EP Ref No :

**SINGAPORE AIRPORT TERMINAL SERVICES LIMITED  
20 AIRPORT BOULEVARD  
SATS INFLIGHT CATERING CENTRE 3  
SINGAPORE 819659**

<b>Sno Code/Description</b>	<b>Unit Price (S\$)</b>	<b>Qty</b>	<b>Amount</b>
1 Lodgment Of Return Of Allotment Of Share <b>COMPANY NAME :</b> 197201770G / SINGAPORE AIRPORT TERMINAL SERVICES LIMITED	10.00	1	10.00
<b>Total (S\$) :</b>			<b>10.00</b>

**Deposit Service Account No. : 030066**  
**Balance Amount in Deposit Account : \$ 355.00**

This is a computer-generated receipt. No signature is required.

Please print a copy of the receipt for your reference.

[HOME](#)[LOGOUT](#)



**Return of Allotment of Shares**

Submit

Please fill in the following information. Fields marked \* must be completed.

Resolution/Declaration	Shares payable in cash	For a consideration other than cash	Share Capital/Allottees Particulars	List of Shareholders after the allotment	Summary of Capital
------------------------	------------------------	-------------------------------------	-------------------------------------	--	--------------------

Record saved successfully.

**Company Type**

Please click on appropriate button :

- company is listed on the securities exchange ✓
- company is an unlisted public company
- company is a private company

**Power under Section 161 of the Companies Act \***

The directors have obtained the approval of the company in general meeting to issue shares.

Yes ✓

No

**Resolution Made**

\* You are only required to fill in this section if the directors are not given the power under Section 161 of the Companies Act to issue shares.

Registration No. : **197201770G**Company Name : **SINGAPORE AIRPORT TERMINAL SERVICES LIMITED**

Nature of Meeting : \* Directors ▼

Place of Meeting : \*

Date of Meeting : \* (dd/mm/yyyy)

Resolution Type : \* Director's ▼

Description : \*  
(max 2000 characters)Attachment : \*  
(copy of resolution)**Note :**

Uploaded file name will be changed by suffixing time-stamp with the actual file name as

filenameyyyyMMddmmsstt

Browse...

(Click 'Browse' to select file for attachment)

**Persons signing the resolution**

Please indicate the directors/ secretaries who signed the resolution :

- S0036442H / OW CHIN HOCK
- S0070715E / NG KEE CHOE
- S0234645A / CHEW CHOON SENG
- S1001765C / BARRY HENRY PATRICK DESKER
- S1069567H / TAN JIAK NGEЕ MICHAEL
- S1673157I / YIP WAI PING ANNABELLE
- S1852301I / HONG HAI @ HUANG HAI
- S2163476Z / CHENG WAI WING EDMUND
- S2580327B / RICHARD CHARLES HELFER

Please enter names of other corporate representatives who signed the resolution, if applicable :

**Declaration**

I, LIM HONG ENG SUSANNA, Professional body/service bureau, declare the information which has been submitted herein to be true to the best of my knowledge.

**Return of Allotment of Shares****Submit**

Please fill in the following information. Fields marked \* must be completed.

<u>Resolution / Declaration</u>	<u>Share payable in cash</u>	<u>For a consideration other than cash</u>	<u>Share Capital / Allottees Particulars</u>	<u>List of Shareholders after the Allotment</u>	<u>Summary of Capital</u>
---------------------------------	------------------------------	--	--	---	---------------------------

**Authorised Capital**

	<u>Amount</u>	<u>Nominal Value per Share</u>	<u>Currency</u>
Authorised Capital :	<b>20000000</b>	<b>.1</b>	<b>SINGAPORE DOLLAR ( 099 )</b>

Description of discrepancy :

**Return of Allotment of Shares (Payable in cash) \***

Applicable only if share is payable in cash

<u>Class of Shares :</u>	<u>Ordinary</u>	<u>Preference</u>	<u>Others</u>
Number of shares :	<input type="text" value="105200"/>	<input type="text"/>	<input type="text"/>
Amount paid or due and payable on each share			
paid :	<input type="text" value="0.10"/>	<input type="text"/>	<input type="text"/>
due and payable :	<input type="text" value="0"/>	<input type="text"/>	<input type="text"/>
Amount of premium paid or payable on each share :	<input type="text" value="1.50"/>	<input type="text"/>	<input type="text"/>

<b>Save</b>	<b>Delete Issued Share</b>	<b>Reset</b>	<b>Back</b>
-------------	----------------------------	--------------	-------------

**Return of Allotment of Shares****Submit**

Please fill in the following information. Fields marked \* must be completed.

<u>Resolution / Declaration</u>	<u>Share payable in cash</u>	<u>For a consideration other than cash</u>	<u>Share Capital / Allottees Particulars</u>	<u>List of Shareholders after the allotment</u>	<u>Summary of Capital</u>
---------------------------------	------------------------------	--	--	---	---------------------------

**Particulars of Allottee****Please indicate whether the allottee is an Individual : \***

- Allottee is an Individual  
 Allottee is NOT an Individual

**If Allottee is an Individual :** ✓Shareholder Category : \* **Individual**Identification No. : \*  **Retrieve Details**Identification Type : \*  ▼Name : \* Nationality : \*  ▼Mobile No : Occupation : Email Address : Address Type : \*  
 Local  
 Foreign

Local Address (\* if Address Type is Local Address)

Postal Code :  **Retrieve Address**Block/House No. :  ▼

Street Name :

Unit : #  - 

Building/Estate Name :

Foreign Address (\* if Address Type is Foreign Address)

Address : **If Allottee is NOT an Individual :**Shareholder Category : \*  ▼ **Search**

Registration No. : \*

198003912M

Retrieve Details

Name :

THE CENTRAL DEPOSITORY (PTE) LIMITED

Address Type :

Local

Local Address (\* if Address Type is Local Address)

Postal Code : **068804**

Block/House No. : **2**

Street Name : **SHENTON WAY**

Unit : # **19 - 00**

Building/Estate Name : **SGX CENTRE I**

Foreign Address (\* if Address Type is Foreign Address)

Address :

**Details of Shares Allotted** \* Please read instructions carefully before entering.

Note : If any share or shares is/are co-owned by 2 or more persons, please assign an alphabet e.g. A to denote the Group and enter the same in the box. Enter the same alphabet in the box for every allottee in the same group. Skip this box if share(s) are owned by only one person.

Group of Share that is co-owned:  
(Share Group)

If share(s) is/are co-owned, only one allottee is to enter details in (a), (b), (c), (d) and (e). Enter "0" (zero) for subsequent allottees in box (b) and leave blank for rest of the items.

a) Nominal Value per Share :

0.10 ✓

b) No. of shares allotted :

105200 ✓

c) Class of shares allotted :

Ordinary ✓

d) Currency :

SINGAPORE DOLLAR (099)

e) Date of allotment :

07/10/2004 (dd/mm/yyyy)

Save

Reset

Back

**Return of Allotment of Shares****Submit**

Please fill in the following information. Fields marked \* must be completed.

<b>Resolution / Declaration</b>	<b>Share payable in cash</b>	<b>For a consideration other than cash</b>	<b>Share Capital / Allottees Particulars</b>	<b>List of Shareholders after Allotment</b>	<b>Summary of Capital</b>
-------------------------------------	----------------------------------	--	--	---	-------------------------------

**List of Allottees and their particulars****Identification****No./Registration Name  
No.****Shareholder Category**

198003912M	THE CENTRAL DEPOSITORY (PTE) LIMITED	Company / Foreign Branch
------------	---	--------------------------

If No. of shareholders exceeds 50, total No. of issued shares held by the remaining shareholders are :

	<b>Ordinary</b>	<b>Preference</b>	<b>Others</b>
<b>No. of Shares</b>	0	0	0

**Return of Allotment of Shares****Submit**

Please fill in the following information. Fields marked \* must be completed.

<u>Resolution / Declaration</u>	<u>Share payable in cash</u>	<u>For a consideration other than cash</u>	<u>Share Capital / Allottees Particulars</u>	<u>List of Shareholders after the allotment</u>	<u>Summary of Capital</u>
-------------------------------------	----------------------------------	--	--	---	-------------------------------

**Share Capital (1)**

Currency :	<b>SINGAPORE DOLLAR (099)</b>		
Nominal Value per Share :	<b>0.10</b>		
Amount of Authorised Share Capital :	<b>200000000.00</b>		
Class of Shares :	Ordinary	Preference	Others
Amount of Issued Share Capital :	<b>102476107.50</b>	<b>0.00</b>	<b>0.00</b>
Amount of Paid-up Share Capital :	<b>102476107.50</b>	<b>0.00</b>	<b>0.00</b>

**RECEIPT**

Receipt No : ACR0000000891116A

Date/Time : 13/10/2004 10:43

Transaction  
No : C040464799

Agency : RCB - RCB

Application : BIZFILE PAYMENT SERVICE

Paid via : Deposit Service Account

EP Ref No :

**SINGAPORE AIRPORT TERMINAL SERVICES LIMITED**  
**20 AIRPORT BOULEVARD**  
**SATS INFLIGHT CATERING CENTRE 3**  
**SINGAPORE 819659**

<b>Sno Code/Description</b>	<b>Unit Price (S\$)</b>	<b>Qty</b>	<b>Amount</b>
1 Lodgment Of Return Of Allotment Of Share <b>COMPANY NAME :</b> 197201770G / SINGAPORE AIRPORT TERMINAL SERVICES LIMITED	10.00	1	10.00
<b>Total (S\$) :</b>			<b>10.00</b>

**Deposit Service Account No. : 030066**  
**Balance Amount in Deposit Account : \$ 365.00**

This is a computer-generated receipt. No signature is required.

Please print a copy of the receipt for your reference.

[HOME](#)[LOGOUT](#)



**LOCAL COMPANY TRANSACTIONS**[HOME](#) [LOGOUT](#)**Return of Allotment of Shares**[Submit](#)

Please fill in the following information. Fields marked \* must be completed.

Resolution/Declaration	Shares payable in cash	For a consideration other than cash	Share Capital/Allottees Particulars	List of Shareholders after the allotment	Summary of Capital
------------------------	------------------------	-------------------------------------	-------------------------------------	--	--------------------

**Record saved successfully.****Company Type**

Please click on appropriate button :

- company is listed on the securities exchange
- company is an unlisted public company
- company is a private company

**Power under Section 161 of the Companies Act \***

The directors have obtained the approval of the company in general meeting to issue shares.

Yes  No

**Resolution Made**

\* You are only required to fill in this section if the directors are not given the power under Section 161 of the Companies Act to issue shares.

Registration No. : **197201770G**Company Name : **SINGAPORE AIRPORT TERMINAL SERVICES LIMITED**Nature of Meeting : \* Place of Meeting : \* Date of Meeting : \*  (dd/mm/yyyy)Resolution Type : \* Description : \* (max 2000 characters) 

Attachment : \* (copy of resolution)

**Note :** Uploaded file name will be changed by suffixing time-stamp with the actual file name as **filenameyyyyMMddmmsstt**

[Browse...](#)

(Click 'Browse' to select file for attachment)

### Persons signing the resolution

Please indicate the directors/ secretaries who signed the resolution :

- S0036442H / OW CHIN HOCK
- S0070715E / NG KEE CHOE
- S0234645A / CHEW CHOON SENG
- S1001765C / BARRY HENRY PATRICK DESKER
- S1069567H / TAN JIAK NGEE MICHAEL
- S1673157I / YIP WAI PING ANNABELLE
- S1852301I / HONG HAI @ HUANG HAI
- S2163476Z / CHENG WAI WING EDMUND
- S2580327B / RICHARD CHARLES HELFER

Please enter names of other corporate representatives who signed the resolution, if applicable :

### Declaration

I, LIM HONG ENG SUSANNA, Professional body/service bureau, declare the information which has been submitted herein to be true to the best of my knowledge.

**Return of Allotment of Shares**

Submit

Please fill in the following information. Fields marked \* must be completed.

Resolution / Declaration	Share payable in cash	For a consideration other than cash	Share Capital / Allottees Particulars	List of Shareholders after the Allotment	Summary of Capital
--------------------------	-----------------------	-------------------------------------	---------------------------------------	--	--------------------

**Authorised Capital**

	Amount	Nominal Value per Share	Currency
Authorised Capital :	<b>200000000</b>	<b>.1</b>	<b>SINGAPORE DOLLAR ( 099 )</b>

Description of discrepancy :

**Return of Allotment of Shares (Payable in cash) \***

Applicable only if share is payable in cash

Class of Shares :	Ordinary	Preference	Others
Number of shares :	41600		
Amount paid or due and payable on each share			
paid :	0.10		
due and payable :	0		
Amount of premium paid or payable on each share :	1.14		

Save

Delete Issued Share

Reset

Back

**Return of Allotment of Shares**

Submit

Please fill in the following information. Fields marked \* must be completed.

<u>Resolution / Declaration</u>	<u>Share payable in cash</u>	<u>For a consideration other than cash</u>	<u>Share Capital / Allottees Particulars</u>	<u>List of Shareholders after the allotment</u>	<u>Summary of Capital</u>
-------------------------------------	----------------------------------	--	--	---	-------------------------------

**Particulars of Allottee**

Please indicate whether the allottee is an Individual : \*

- Allottee is an Individual  
 Allottee is NOT an Individual

If Allottee is an Individual :

Shareholder Category : \* **Individual**Identification No. : \*  Retrieve DetailsIdentification Type : \* Name : \* Nationality : \* Mobile No : Occupation : Email Address : Address Type : \*  
 Local  
 Foreign

Local Address (\* if Address Type is Local Address)

Postal Code :  Retrieve AddressBlock/House No. : 

Street Name :

Unit : #  - 

Building/Estate Name :

Foreign Address (\* if Address Type is Foreign Address)

Address : 

If Allottee is NOT an Individual :

Shareholder Category : \*  Search

Registration No. : \*

198003912M

Retrieve Details

Name :

THE CENTRAL DEPOSITORY (PTE) LIMITED

Address Type :

Local

Local Address (\* if Address Type is Local Address)

Postal Code : **068804**

Block/House No. : **2**

Street Name : **SHENTON WAY**

Unit : # **19 - 00**

Building/Estate Name : **SGX CENTRE I**

Foreign Address (\* if Address Type is Foreign Address)

Address :

**Details of Shares Allotted** \* Please read instructions carefully before entering.

Note : If any share or shares is/are co-owned by 2 or more persons, please assign an alphabet e.g..A to denote the Group and enter the same in the box. Enter the same alphabet in the box for every allottee in the same group. Skip this box if share(s) are owned by only one person.

Group of Share that is co-owned:  
(Share Group)

If share(s) is/are co-owned, only one allottee is to enter details in (a), (b), (c), (d) and (e). Enter "0" (zero) for subsequent allottees in box (b) and leave blank for rest of the items.

a) Nominal Value per Share :

0.10

b) No. of shares allotted :

41600

c) Class of shares allotted :

Ordinary

d) Currency :

SINGAPORE DOLLAR (099)

e) Date of allotment :

07/10/2004 (dd/mm/yyyy)

Save

Reset

Back

**Return of Allotment of Shares****Submit**

Please fill in the following information. Fields marked \* must be completed.

Resolution / Declaration	Share payable in cash	For a consideration other than cash	Share Capital / Allottees Particulars	List of Shareholders after Allotment	Summary of Capital
--------------------------	-----------------------	-------------------------------------	---------------------------------------	--------------------------------------	--------------------

**List of Allottees and their particulars****Identification****No./Registration Name No.****Shareholder Category**

198003912M	THE CENTRAL DEPOSITORY (PTE) LIMITED	Company / Foreign Branch
------------	--------------------------------------	--------------------------

If No. of shareholders exceeds 50, total No. of issued shares held by the remaining shareholders are :

No. of Shares	Ordinary	Preference	Others
	0	0	0

**Return of Allotment of Shares****Submit**

Please fill in the following information. Fields marked \* must be completed.

<u>Resolution / Declaration</u>	<u>Share payable in cash</u>	<u>For a consideration other than cash</u>	<u>Share Capital / Allottees Particulars</u>	<u>List of Shareholders after the allotment</u>	<u>Summary of Capital</u>
<b>Share Capital (1)</b>					
Currency :	<b>SINGAPORE DOLLAR (099)</b>				
Nominal Value per Share :	<b>0.10</b>				
Amount of Authorised Share Capital :	<b>200000000.00</b>				
Class of Shares :	Ordinary	Preference	Others		
Amount of Issued Share Capital :	<b>102465587.50</b>	<b>0.00</b>	<b>0.00</b>		
Amount of Paid-up Share Capital :	<b>102465587.50</b>	<b>0.00</b>	<b>0.00</b>		

GST No. :M9-0008879-T

**RECEIPT**

Receipt No : ACR0000000891083A

Date/Time : 13/10/2004 10:36

Transaction No : C040464761

Agency : RCB - RCB

Application : BIZFILE PAYMENT SERVICE

Paid via : Deposit Service Account

EP Ref No :

**SINGAPORE AIRPORT TERMINAL SERVICES LIMITED**  
**20 AIRPORT BOULEVARD**  
**SATS INFLIGHT CATERING CENTRE 3**  
**SINGAPORE 819659**

<b>Sno Code/Description</b>	<b>Unit Price (\$)</b>	<b>Qty</b>	<b>Amount</b>
1 Lodgment Of Return Of Allotment Of Share <b>COMPANY NAME :</b> 197201770G / SINGAPORE AIRPORT TERMINAL SERVICES LIMITED	10.00	1	10.00
<b>Total (\$):</b>			<b>10.00</b>

**Deposit Service Account No. : 030066**  
**Balance Amount in Deposit Account : \$ 375.00**

This is a computer-generated receipt. No signature is required.

Please print a copy of the receipt for your reference.

[HOME](#)[LOGOUT](#)



**Return of Allotment of Shares****Submit**

Please fill in the following information. Fields marked \* must be completed.

Resolution/Declaration	Shares payable in cash	For a consideration other than cash	Share Capital/Allottees Particulars	List of Shareholders after the allotment	Summary of Capital
------------------------	------------------------	-------------------------------------	-------------------------------------	--	--------------------

**Record saved successfully.****Company Type**

Please click on appropriate button :

- company is listed on the securities exchange
- company is an unlisted public company
- company is a private company

**Power under Section 161 of the Companies Act \***

The directors have obtained the approval of the company in  Yes  No general meeting to issue shares.

**Resolution Made**

\* You are only required to fill in this section if the directors are not given the power under Section 161 of the Companies Act to issue shares.

Registration No. : **197201770G**Company Name : **SINGAPORE AIRPORT TERMINAL SERVICES LIMITED**Nature of Meeting : \* **Directors**Place of Meeting : \* Date of Meeting : \*  (dd/mm/yyyy)Resolution Type : \* **Director's**Description : \*  (max 2000 characters)

Attachment : \* (copy of resolution)

**Note :**  **Browse...**

Uploaded file name will be changed by suffixing time-stamp with the actual file name as **filenameyyyyMMddmmsstt**

(Click 'Browse' to select file for attachment)

### Persons signing the resolution

Please indicate the directors/ secretaries who signed the resolution :

- S0036442H / OW CHIN HOCK
- S0070715E / NG KEE CHOE
- S0234645A / CHEW CHOON SENG
- S1001765C / BARRY HENRY PATRICK DESKER
- S1069567H / TAN JIAK NGEE MICHAEL
- S1673157I / YIP WAI PING ANNABELLE
- S1852301I / HONG HAI @ HUANG HAI
- S2163476Z / CHENG WAI WING EDMUND
- S2580327B / RICHARD CHARLES HELFER

Please enter names of other corporate representatives who signed the resolution, if applicable :

### Declaration

I, LIM HONG ENG SUSANNA, Professional body/service bureau, declare the information which has been submitted herein to be true to the best of my knowledge.

**Return of Allotment of Shares****Submit**

Please fill in the following information. Fields marked \* must be completed.

Resolution / Declaration	Share payable in cash	For a consideration other than cash	Share Capital / Allottees Particulars	List of Shareholders after the Allotment	Summary of Capital
--------------------------	-----------------------	-------------------------------------	---------------------------------------	--	--------------------

**Authorised Capital**

	Amount	Nominal Value per Share	Currency
Authorised Capital :	<b>20000000</b>	<b>.1</b>	<b>SINGAPORE DOLLAR ( 099 )</b>

Description of discrepancy :

**Return of Allotment of Shares (Payable in cash) \***

Applicable only if share is payable in cash

Class of Shares :	Ordinary	Preference	Others
Number of shares :	<input type="text" value="120200"/>	<input type="text"/>	<input type="text"/>
Amount paid or due and payable on each share			
paid :	<input type="text" value="0.10"/>	<input type="text"/>	<input type="text"/>
due and payable :	<input type="text" value="0"/>	<input type="text"/>	<input type="text"/>
Amount of premium paid or payable on each share :	<input type="text" value="1.70"/>	<input type="text"/>	<input type="text"/>

**Save****Delete Issued Share****Reset****Back**

**Return of Allotment of Shares****Submit**

Please fill in the following information. Fields marked \* must be completed.

Resolution / Declaration	Share payable in cash	For a consideration other than cash	Share Capital / Allottees Particulars	List of Shareholders after the allotment	Summary of Capital
--------------------------	-----------------------	-------------------------------------	---------------------------------------	--	--------------------

**Particulars of Allottee****Please indicate whether the allottee is an Individual : \***

- Allottee is an Individual  
 Allottee is NOT an Individual

**If Allottee is an Individual :**Shareholder Category : \* **Individual**Identification No. : \*  **Retrieve Details**Identification Type : \*  ▼Name : \* Nationality : \*  ▼Mobile No : Occupation : Email Address : Address Type : \*  
 Local  
 Foreign

Local Address (\* if Address Type is Local Address)

Postal Code :  **Retrieve Address**Block/House No. : Street Name : Unit : #  - Building/Estate Name : 

Foreign Address (\* if Address Type is Foreign Address)

Address : **If Allottee is NOT an Individual :**Shareholder Category : \*  ▼ **Search**

Registration No. : \*

198003912M

Retrieve Details

Name :

THE CENTRAL DEPOSITORY (PTE) LIMITED

Address Type :

Local

Local Address (\* if Address Type is Local Address)

Postal Code : **068804**

Block/House No. : **2**

Street Name : **SHENTON WAY**

Unit : # **19 - 00**

Building/Estate Name : **SGX CENTRE 1**

Foreign Address (\* if Address Type is Foreign Address)

Address :

**Details of Shares Allotted** \* Please read instructions carefully before entering.

Note : If any share or shares is/are co-owned by 2 or more persons, please assign an alphabet e.g. A to denote the Group and enter the same in the box. Enter the same alphabet in the box for every allottee in the same group. Skip this box if share(s) are owned by only one person.

Group of Share that is co-owned:  
(Share Group)

If share(s) is/are co-owned, only one allottee is to enter details in (a), (b), (c), (d) and (e). Enter "0" (zero) for subsequent allottees in box (b) and leave blank for rest of the items.

a) Nominal Value per Share :

0.10 ✓

b) No. of shares allotted :

120200 ✓

c) Class of shares allotted :

Ordinary ✓

d) Currency :

SINGAPORE DOLLAR (099) ✓

e) Date of allotment :

07/10/2004 (dd/mm/yyyy) ✓

Save

Reset

Back

**Return of Allotment of Shares**[Submit](#)

Please fill in the following information. Fields marked \* must be completed.

<b>Resolution / Declaration</b>	<b>Share payable in cash</b>	<b>For a consideration other than cash</b>	<b>Share Capital / Allottees Particulars</b>	<b>List of Shareholders after Allotment</b>	<b>Summary of Capital</b>
-------------------------------------	----------------------------------	--	--	---	-------------------------------

**List of Allottees and their particulars****Identification****No./Registration Name  
No.****Shareholder Category**

198003912M	THE CENTRAL DEPOSITORY (PTE) LIMITED	Company / Foreign Branch
------------	---	--------------------------

If No. of shareholders exceeds 50, total No. of issued shares held by the remaining shareholders are :

<b>No. of Shares</b>	<b>Ordinary</b>	<b>Preference</b>	<b>Others</b>
	0	0	0

**Return of Allotment of Shares****Submit**

Please fill in the following information. Fields marked \* must be completed.

Resolution / Declaration	Share payable in cash	For a consideration other than cash	Share Capital / Allottees Particulars	List of Shareholders after the allotment	Summary of Capital
-----------------------------	--------------------------	---	---	---	-----------------------

**Share Capital (1)**

Currency :	<b>SINGAPORE DOLLAR (099)</b>				
Nominal Value per Share :	<b>0.10</b>				
Amount of Authorised Share Capital :	<b>200000000.00</b>				
Class of Shares :	Ordinary	Preference	Others		
Amount of Issued Share Capital :	<b>102461427.50</b>	<b>0.00</b>	<b>0.00</b>		
Amount of Paid-up Share Capital :	<b>102461427.50</b>	<b>0.00</b>	<b>0.00</b>		

**RECEIPT**

Receipt No : ACR0000000889109A

Date/Time : 12/10/2004 09:49

Transaction  
No : C040462638

Agency : RCB - RCB

Application : BIZFILE PAYMENT SERVICE

Paid via : Deposit Service Account

EP Ref No :

**SINGAPORE AIRPORT TERMINAL SERVICES LIMITED  
20 AIRPORT BOULEVARD  
SATS INFLIGHT CATERING CENTRE 3  
SINGAPORE 819659**

<b>Sno Code/Description</b>	<b>Unit Price (S\$)</b>	<b>Qty</b>	<b>Amount</b>
1 Lodgment Of Return Of Allotment Of Share <b>COMPANY NAME :</b> 197201770G / SINGAPORE AIRPORT TERMINAL SERVICES LIMITED	10.00	1	10.00
<b>Total (S\$) :</b>			<b>10.00</b>

**Deposit Service Account No. : 030066**  
**Balance Amount in Deposit Account : \$ 385.00**

This is a computer-generated receipt. No signature is required.

Please print a copy of the receipt for your reference.

[HOME](#)[LOGOUT](#)



**Return of Allotment of Shares****Submit**

Please fill in the following information. Fields marked \* must be completed.

Resolution/Declaration	Shares payable in cash	For a consideration other than cash	Share Capital/Allottees Particulars	List of Shareholders after the allotment	Summary of Capital
------------------------	---------------------------	---	---	---	-----------------------

**Record saved successfully.****Company Type**

Please click on appropriate button :

- company is listed on the securities exchange /  
 company is an unlisted public company  
 company is a private company

**Power under Section 161 of the Companies Act \***

The directors have obtained  
the approval of the company in  Yes  
general meeting to issue  No  
shares.

**Resolution Made**

\* You are only required to fill in this section if the directors are not given the power under Section 161 of the Companies Act to issue shares.

Registration No. : **197201770G**Company Name : **SINGAPORE AIRPORT TERMINAL SERVICES LIMITED**

Nature of Meeting : \* Directors

Place of Meeting : \*

Date of Meeting : \* (dd/mm/yyyy)

Resolution Type : \* Director's

Description : \*  
(max 2000 characters)Attachment : \*  
(copy of resolution)**Note :**

Uploaded file name will be  
changed by suffixing time-  
stamp with the actual file  
name as

filenameyyyyMMddmmsstt

**Browse...**

(Click 'Browse' to select file for attachment)

### Persons signing the resolution

Please indicate the directors/ secretaries who signed the resolution :

- S0036442H / OW CHIN HOCK
- S0070715E / NG KEE CHOE
- S0234645A / CHEW CHOON SENG
- S1001765C / BARRY HENRY PATRICK DESKER
- S1069567H / TAN JIAK NGEE MICHAEL
- S1673157I / YIP WAI PING ANNABELLE
- S1852301I / HONG HAI @ HUANG HAI
- S2163476Z / CHENG WAI WING EDMUND
- S2580327B / RICHARD CHARLES HELFER

Please enter  
names of other  
corporate  
representatives  
who signed the  
resolution, if  
applicable :

### Declaration

I, LIM HONG ENG SUSANNA, Professional body/service bureau, declare the information which has been submitted herein to be true to the best of my knowledge.

**Return of Allotment of Shares**

[Submit](#)

Please fill in the following information. Fields marked \* must be completed.

Resolution / Declaration	Share payable in cash	For a consideration other than cash	Share Capital / Allottees Particulars	List of Shareholders after the Allotment	Summary of Capital
--------------------------	-----------------------	-------------------------------------	---------------------------------------	--	--------------------

**Authorised Capital**

	Amount	Nominal Value per Share	Currency
Authorised Capital :	<b>20000000</b>	<b>.1</b>	<b>SINGAPORE DOLLAR ( 099 )</b>

Description of discrepancy :

**Return of Allotment of Shares (Payable in cash) \***

Applicable only if share is payable in cash

Class of Shares :	Ordinary	Preference	Others
Number of shares :	<input type="text" value="13000"/>	<input type="text"/>	<input type="text"/>
Amount paid or due and payable on each share			
paid :	<input type="text" value="0.10"/>	<input type="text"/>	<input type="text"/>
due and payable :	<input type="text" value="0"/>	<input type="text"/>	<input type="text"/>
Amount of premium paid or payable on each share :	<input type="text" value="1.50"/>	<input type="text"/>	<input type="text"/>

[Save](#) [Delete Issued Share](#) [Reset](#) [Back](#)

**Return of Allotment of Shares****Submit**

Please fill in the following information. Fields marked \* must be completed.

<u>Resolution / Declaration</u>	<u>Share payable in cash</u>	<u>For a consideration other than cash</u>	<u>Share Capital / Allottees Particulars</u>	<u>List of Shareholders after the allotment</u>	<u>Summary of Capital</u>
-------------------------------------	----------------------------------	--	--	---	-------------------------------

**Particulars of Allottee**

Please indicate whether the allottee is an Individual : \*

- Allottee is an Individual  
 Allottee is NOT an Individual

If Allottee is an Individual :

Shareholder Category : \* **Individual**Identification No. : \*  **Retrieve Details**Identification Type : \* Name : \* Nationality : \* Mobile No : Occupation : Email Address : Address Type : \*  
 Local  
 Foreign

Local Address (\* if Address Type is Local Address)

Postal Code :  **Retrieve Address**Block/House No. : Street Name : Unit : #  - Building/Estate Name : 

Foreign Address (\* if Address Type is Foreign Address)

Address :   

If Allottee is NOT an Individual :

Shareholder Category : \*  **Search**

Registration NO. :    
Name : **THE CENTRAL DEPOSITORY (PTE) LIMITED**

Address Type : **Local**

Local Address (\* if Address Type is Local Address)

Postal Code : **068804**

Block/House No. : **2**

Street Name : **SHENTON WAY**

Unit : # **19 - 00**

Building/Estate Name : **SGX CENTRE I**

Foreign Address (\* if Address Type is Foreign Address)

Address :

**Details of Shares Allotted** \* Please read instructions carefully before entering.

Note : If any share or shares is/are co-owned by 2 or more persons, please assign an alphabet e.g. A to denote the Group and enter the same in the box. Enter the same alphabet in the box for every allottee in the same group. Skip this box if share(s) are owned by only one person.

Group of Share that is co-owned:   
(Share Group)

If share(s) is/are co-owned, only one allottee is to enter details in (a), (b), (c), (d) and (e). Enter "0" (zero) for subsequent allottees in box (b) and leave blank for rest of the items.

- a) Nominal Value per Share :
- b) No. of shares allotted :
- c) Class of shares allotted :
- d) Currency :
- e) Date of allotment :  (dd/mm/yyyy)

**Return of Allotment of Shares****Submit**

Please fill in the following information. Fields marked \* must be completed.

<b>Resolution / Declaration</b>	<b>Share payable in cash</b>	<b>For a consideration other than cash</b>	<b>Share Capital / Allottees Particulars</b>	<b>List of Shareholders after Allotment</b>	<b>Summary of Capital</b>
-------------------------------------	----------------------------------	--	--	---	-------------------------------

**List of Allottees and their particulars****Identification****No./Registration Name  
No.****Shareholder Category**

198003912M	THE CENTRAL DEPOSITORY (PTE) LIMITED	Company / Foreign Branch
------------	---	--------------------------

If No. of shareholders exceeds 50, total No. of issued shares held by the remaining shareholders are :

<b>No. of Shares</b>	<b>Ordinary</b>	<b>Preference</b>	<b>Others</b>
	0	0	0

**Return of Allotment of Shares**

Please fill in the following information. Fields marked \* must be completed.

Resolution / Declaration	Share payable in cash	For a consideration other than cash	Share Capital / Allottees Particulars	List of Shareholders after the allotment	Summary of Capital
-----------------------------	--------------------------	---	---	---	-----------------------

**Share Capital (1)**

Currency :	<b>SINGAPORE DOLLAR (099)</b>		
Nominal Value per Share :	<b>0.10</b>		
Amount of Authorised Share Capital :	<b>200000000.00</b>		
Class of Shares :	Ordinary	Preference	Others
Amount of Issued Share Capital :	<b>102449407.50</b>	<b>0.00</b>	<b>0.00</b>
Amount of Paid-up Share Capital :	<b>102449407.50</b>	<b>0.00</b>	<b>0.00</b>

**RECEIPT**

Receipt No : ACR0000000889075A

Date/Time : 12/10/2004 09:43

Transaction No : C040462599

Agency : RCB - RCB

Application : BIZFILE PAYMENT SERVICE

Paid via : Deposit Service Account

EP Ref No :

**SINGAPORE AIRPORT TERMINAL SERVICES LIMITED**  
**20 AIRPORT BOULEVARD**  
**SATS INFLIGHT CATERING CENTRE 3**  
**SINGAPORE 819659**

Sno Code/Description	Unit Price (S\$)	Qty	Amount
1 Lodgment Of Return Of Allotment Of Share <b>COMPANY NAME :</b> 197201770G / SINGAPORE AIRPORT TERMINAL SERVICES LIMITED	10.00	1	10.00
Total (S\$) :			10.00

**Deposit Service Account No. : 030066**  
**Balance Amount in Deposit Account : \$ 395.00**

This is a computer-generated receipt. No signature is required.

Please print a copy of the receipt for your reference.

[HOME](#)[LOGOUT](#)



**Return of Allotment of Shares****Submit**

Please fill in the following information. Fields marked \* must be completed.

Resolution/Declaration	Shares payable in cash	For a consideration other than cash	Share Capital/Allottees Particulars	List of Shareholders after the allotment	Summary of Capital
------------------------	---------------------------	---	---	---	-----------------------

**Record saved successfully.****Company Type**

Please click on appropriate button :

- company is listed on the securities exchange  
 company is an unlisted public company  
 company is a private company

**Power under Section 161 of the Companies Act \***

The directors have obtained  
the approval of the company in  Yes  
general meeting to issue  No  
shares.

**Resolution Made**

\* You are only required to fill in this section if the directors are not given the power under Section 161 of the Companies Act to issue shares.

Registration No. : **197201770G**Company Name : **SINGAPORE AIRPORT TERMINAL SERVICES LIMITED**Nature of Meeting : \* 

Place of Meeting : \*

Date of Meeting: \*  (dd/mm/yyyy)Resolution Type : \* Description : \*  
(max 2000 characters)Attachment : \*  
(copy of resolution)**Note :**

Uploaded file name will be  
changed by suffixing time-  
stamp with the actual file  
name as

**filenameyyyyMMddmmsstt****Browse...**

(Click 'Browse' to select file for attachment)

### Persons signing the resolution

Please indicate the directors/ secretaries who signed the resolution :

- S0036442H / OW CHIN HOCK
- S0070715E / NG KEE CHOE
- S0234645A / CHEW CHOON SENG
- S1001765C / BARRY HENRY PATRICK DESKER
- S1069567H / TAN JIAK NGEЕ MICHAEL
- S1673157I / YIP WAI PING ANNABELLE
- S1852301I / HONG HAI @ HUANG HAI
- S2163476Z / CHENG WAI WING EDMUND
- S2580327B / RICHARD CHARLES HELFER

Please enter  
names of other  
corporate  
representatives  
who signed the  
resolution, if  
applicable :

### Declaration

I, LIM HONG ENG SUSANNA, Professional body/service bureau, declare the information which has been submitted herein to be true to the best of my knowledge.

**Return of Allotment of Shares****Submit**

Please fill in the following information. Fields marked \* must be completed.

Resolution / Declaration	Share payable in cash	For a consideration other than cash	Share Capital / Allottees Particulars	List of Shareholders after the Allotment	Summary of Capital
--------------------------	-----------------------	-------------------------------------	---------------------------------------	--	--------------------

**Authorised Capital**

	Amount	Nominal Value per Share	Currency
Authorised Capital :	<b>20000000</b>	<b>.1</b>	<b>SINGAPORE DOLLAR ( 099 )</b>

Description of discrepancy :

**Return of Allotment of Shares (Payable in cash) \***

Applicable only if share is payable in cash

Class of Shares :	Ordinary	Preference	Others
Number of shares :	6000		
Amount paid or due and payable on each share			
paid :	0.10		
due and payable :	0		
Amount of premium paid or payable on each share :	1.14		

**Save****Delete Issued Share****Reset****Back**

**Return of Allotment of Shares****Submit**

Please fill in the following information. Fields marked \* must be completed.

Resolution / Declaration	Share payable in cash	For a consideration other than cash	Share Capital / Allottees Particulars	List of Shareholders after the allotment	Summary of Capital
--------------------------	-----------------------	-------------------------------------	---------------------------------------	--	--------------------

**Particulars of Allottee**

Please indicate whether the allottee is an Individual : \*

- Allottee is an Individual  
 Allottee is NOT an Individual

If Allottee is an Individual :

Shareholder Category : \* **Individual**Identification No. : \*  **Retrieve Details**Identification Type : \*  ▼Name : \* Nationality : \*  ▼Mobile No : Occupation : Email Address : Address Type : \*  
 Local  
 Foreign

Local Address (\* if Address Type is Local Address)

Postal Code :  **Retrieve Address**Block/House No. :  ▼Street Name : Unit : #  - Building/Estate Name : 

Foreign Address (\* if Address Type is Foreign Address)

Address : 

If Allottee is NOT an Individual :

Shareholder Category : \*  ▼ **Search**

Registration No. :  THE CENTRAL DEPOSITORY (PTE) LIMITED

Address Type : **Local**

Local Address (\* if Address Type is Local Address)

Postal Code : **068804**

Block/House No. : **2**

Street Name : **SHENTON WAY**

Unit : # **19 - 00**

Building/Estate Name : **SGX CENTRE I**

Foreign Address (\* if Address Type is Foreign Address)

Address :

**Details of Shares Allotted** \* Please read instructions carefully before entering.

Note : If any share or shares is/are co-owned by 2 or more persons, please assign an alphabet e.g. A to denote the Group and enter the same in the box. Enter the same alphabet in the box for every allottee in the same group. Skip this box if share(s) are owned by only one person.

Group of Share that is co-owned:

If share(s) is/are co-owned, only one allottee is to enter details in (a), (b), (c), (d) and (e). Enter "0" (zero) for subsequent allottees in box (b) and leave blank for rest of the items.

a) Nominal Value per Share :

b) No. of shares allotted :

c) Class of shares allotted :

d) Currency :

e) Date of allotment :  (dd/mm/yyyy)

**Return of Allotment of Shares****Submit**

Please fill in the following information. Fields marked \* must be completed.

Resolution / Declaration	Share payable in cash	For a consideration other than cash	Share Capital / Allottees Particulars	List of Shareholders after Allotment	Summary of Capital
-----------------------------	--------------------------	---	---	--	-----------------------

**List of Allottees and their particulars****Identification**

No./Registration No.	Name	Shareholder Category
-------------------------	------	----------------------

198003912M

THE CENTRAL DEPOSITORY (PTE)  
LIMITED

Company / Foreign Branch

If No. of shareholders exceeds 50, total No. of issued shares held by the remaining shareholders are :

No. of Shares	Ordinary	Preference	Others
	0	0	0

**Return of Allotment of Shares****Submit**

Please fill in the following information. Fields marked \* must be completed.

Resolution / Declaration	Share payable in cash	For a consideration other than cash	Share Capital / Allottees Particulars	List of Shareholders after the allotment	Summary of Capital
<b>Share Capital (1)</b>					
Currency :	<b>SINGAPORE DOLLAR (099)</b>				
Nominal Value per Share :	<b>0.10</b>				
Amount of Authorised Share Capital :	<b>200000000.00</b>				
Class of Shares :	Ordinary	Preference	Others		
Amount of Issued Share Capital :	<b>102448107.50</b>	<b>0.00</b>	<b>0.00</b>		
Amount of Paid-up Share Capital :	<b>102448107.50</b>	<b>0.00</b>	<b>0.00</b>		

**RECEIPT**

Receipt No : ACR0000000889039A

Date/Time : 12/10/2004 09:35

Transaction No : C040462568

Agency : RCB - RCB

Application : BIZFILE PAYMENT SERVICE

Paid via : Deposit Service Account

EP Ref No :

**SINGAPORE AIRPORT TERMINAL SERVICES LIMITED**  
**20 AIRPORT BOULEVARD**  
**SATS INFLIGHT CATERING CENTRE 3**  
**SINGAPORE 819659**

<b>Sno</b>	<b>Code/Description</b>	<b>Unit Price (S\$)</b>	<b>Qty</b>	<b>Amount</b>
1	Lodgment Of Return Of Allotment Of Share <b>COMPANY NAME :</b> 197201770G / SINGAPORE AIRPORT TERMINAL SERVICES LIMITED	10.00	1	10.00
			<b>Total (S\$) :</b>	10.00

**Deposit Service Account No. : 030066**  
**Balance Amount in Deposit Account : \$ 405.00**

This is a computer-generated receipt. No signature is required.

Please print a copy of the receipt for your reference.

[HOME](#)[LOGOUT](#)



**Return of Allotment of Shares****Submit**

Please fill in the following information. Fields marked \* must be completed.

Resolution/Declaration	Shares payable in cash	For a consideration other than cash	Share Capital/Allottees Particulars	List of Shareholders after the allotment	Summary of Capital
------------------------	---------------------------	---	---	---	-----------------------

**Record saved successfully.****Company Type**

Please click on appropriate button :

- company is listed on the securities exchange ✓
- company is an unlisted public company
- company is a private company

**Power under Section 161 of the Companies Act \***

The directors have obtained  
the approval of the company in  Yes ✓  
general meeting to issue  No  
shares.

**Resolution Made**

\* You are only required to fill in this section if the directors are not given the power under Section 161 of the Companies Act to issue shares.

Registration No. : **197201770G**Company Name : **SINGAPORE AIRPORT TERMINAL SERVICES LIMITED**

Nature of Meeting : \* Directors ▼

Place of Meeting : \*

Date of Meeting : \* (dd/mm/yyyy)

Resolution Type : \* Director's ▼

Description : \*  
(max 2000 characters)Attachment : \*  
(copy of resolution)**Note :**

Uploaded file name will be  
changed by suffixing time-  
stamp with the actual file  
name as

filenameyyyyMMddmmsst

**Browse...**

(Click 'Browse' to select file for attachment)

**Persons signing the resolution**

Please indicate the directors/ secretaries who signed the resolution :

- S0036442H / OW CHIN HOCK
- S0070715E / NG KEE CHOE
- S0234645A / CHEW CHOON SENG
- S1001765C / BARRY HENRY PATRICK DESKER
- S1069567H / TAN JIAK NGEE MICHAEL
- S1673157I / YIP WAI PING ANNABELLE
- S1852301I / HONG HAI @ HUANG HAI
- S2163476Z / CHENG WAI WING EDMUND
- S2580327B / RICHARD CHARLES HELFER

Please enter names of other corporate representatives who signed the resolution, if applicable :

**Declaration**

I, LIM HONG ENG SUSANNA, Professional body/service bureau, declare the information which has been submitted herein to be true to the best of my knowledge.

**Return of Allotment of Shares**

Submit

Please fill in the following information. Fields marked \* must be completed.

Resolution / Declaration	Share payable in cash	For a consideration other than cash	Share Capital / Allottees Particulars	List of Shareholders after the Allotment	Summary of Capital
--------------------------	-----------------------	-------------------------------------	---------------------------------------	--	--------------------

**Authorised Capital**

	Amount	Nominal Value per Share	Currency
Authorised Capital :	<b>200000000</b>	<b>.1</b>	<b>SINGAPORE DOLLAR ( 099 )</b>

Description of discrepancy :

**Return of Allotment of Shares (Payable in cash) \***

Applicable only if share is payable in cash

Class of Shares :	Ordinary	Preference	Others
Number of shares :	15600		
Amount paid or due and payable on each share			
paid :	0.10		
due and payable :	0		
Amount of premium paid or payable on each share :	1.70		

Save

Delete Issued Share

Reset

Back

**Return of Allotment of Shares****Submit**

Please fill in the following information. Fields marked \* must be completed.

Resolution / Declaration	Share payable in cash	For a consideration other than cash	Share Capital / Allottees Particulars	List of Shareholders after the allotment	Summary of Capital
--------------------------	-----------------------	-------------------------------------	---------------------------------------	--	--------------------

**Particulars of Allottee**

Please indicate whether the allottee is an Individual : \*

- Allottee is an Individual
- Allottee is NOT an Individual

If Allottee is an Individual :

Shareholder Category : \* **Individual**

Identification No. : \*  **Retrieve Details**

Identification Type : \*

Name : \*

Nationality : \*

Mobile No :

Occupation :

Email Address :

Address Type : \*  Local  Foreign

Local Address (\* if Address Type is Local Address)

Postal Code :  **Retrieve Address**

Block/House No. :

Street Name :

Unit : #  -

Building/Estate Name : 

Foreign Address (\* if Address Type is Foreign Address)

Address :

If Allottee is NOT an Individual :

Shareholder Category : \*  **Search**

Registration No. :  Name : **THE CENTRAL DEPOSITORY (PTE) LIMITED**

Address Type : **Local**

Local Address (\* if Address Type is Local Address)

Postal Code : **068804**

Block/House No. : **2**

Street Name : **SHENTON WAY**

Unit : # **19 - 00**

Building/Estate Name : **SGX CENTRE I**

Foreign Address (\* if Address Type is Foreign Address)

Address :

**Details of Shares Allotted** \* Please read instructions carefully before entering.

Note : If any share or shares is/are co-owned by 2 or more persons, please assign an alphabet e.g. A to denote the Group and enter the same in the box. Enter the same alphabet in the box for every allottee in the same group. Skip this box if share(s) are owned by only one person.

Group of Share that is co-owned:  
(Share Group)

If share(s) is/are co-owned, only one allottee is to enter details in (a), (b), (c), (d) and (e). Enter "0" (zero) for subsequent allottees in box (b) and leave blank for rest of the items.

a) Nominal Value per Share :

b) No. of shares allotted :

c) Class of shares allotted :

d) Currency :

e) Date of allotment :  (dd/mm/yyyy)

**Return of Allotment of Shares****Submit**

Please fill in the following information. Fields marked \* must be completed.

<b>Resolution / Declaration</b>	<b>Share payable in cash</b>	<b>For a consideration other than cash</b>	<b>Share Capital / Allottees Particulars</b>	<b>List of Shareholders after Allotment</b>	<b>Summary of Capital</b>
-------------------------------------	----------------------------------	--	--	---	-------------------------------

**List of Allottees and their particulars****Identification****No./Registration Name  
No.****Shareholder Category**

198003912M	THE CENTRAL DEPOSITORY (PTE) LIMITED	Company / Foreign Branch
------------	---	--------------------------

If No. of shareholders exceeds 50, total No. of issued shares held by the remaining shareholders are :

	<b>Ordinary</b>	<b>Preference</b>	<b>Others</b>
<b>No. of Shares</b>	<b>0</b>	<b>0</b>	<b>0</b>

**Return of Allotment of Shares****Submit**

Please fill in the following information. Fields marked \* must be completed.

Resolution / Declaration	Share payable in cash	For a consideration other than cash	Share Capital / Allottees Particulars	List of Shareholders after the allotment	Summary of Capital
--------------------------	-----------------------	-------------------------------------	---------------------------------------	--	--------------------

**Share Capital (1)**

Currency :	<b>SINGAPORE DOLLAR (099)</b>		
Nominal Value per Share :	<b>0.10</b>		
Amount of Authorised Share Capital :	<b>200000000.00</b>		
Class of Shares :	Ordinary	Preference	Others
Amount of Issued Share Capital :	<b>102447507.50</b>	<b>0.00</b>	<b>0.00</b>
Amount of Paid-up Share Capital :	<b>102447507.50</b>	<b>0.00</b>	<b>0.00</b>

**RECEIPT**

Receipt No : ACR0000000887848A

Date/Time : 11/10/2004 12:47

Transaction  
No : C040461231

Agency : RCB - RCB

Application : BIZFILE PAYMENT SERVICE

Paid via : Deposit Service Account

EP Ref No :

**SINGAPORE AIRPORT TERMINAL SERVICES LIMITED****20 AIRPORT BOULEVARD****SATS INFLIGHT CATERING CENTRE 3****SINGAPORE 819659**

---

<b>Sno Code/Description</b>	<b>Unit Price (S\$)</b>	<b>Qty Amount</b>	
1 Lodgment Of Return Of Allotment Of Share	10.00	1	10.00
<b>COMPANY NAME :</b> 197201770G / SINGAPORE AIRPORT TERMINAL SERVICES LIMITED			
<hr/>			<hr/>
Total (S\$) :			10.00

---

**Deposit Service Account No. : 030066****Balance Amount in Deposit Account : \$ 415.00**

This is a computer-generated receipt. No signature is required.

Please print a copy of the receipt for your reference.

[HOME](#)[LOGOUT](#)



**Return of Allotment of Shares**

Submit

Please fill in the following information. Fields marked \* must be completed.

Resolution/Declaration	Shares payable in cash	For a consideration other than cash	Share Capital/Allottees Particulars	List of Shareholders after the allotment	Summary of Capital
------------------------	---------------------------	---	---	---	-----------------------

**Record saved successfully.****Company Type**

Please click on appropriate button :

- company is listed on the securities exchange  
 company is an unlisted public company  
 company is a private company

**Power under Section 161 of the Companies Act \***

The directors have obtained the approval of the company in  Yes  No general meeting to issue shares.

**Resolution Made**

\* You are only required to fill in this section if the directors are not given the power under Section 161 of the Companies Act to issue shares.

Registration No. : **197201770G**Company Name : **SINGAPORE AIRPORT TERMINAL SERVICES LIMITED**

Nature of Meeting : \* Directors ▼

Place of Meeting : \*

Date of Meeting : \* (dd/mm/yyyy)

Resolution Type : \* Director's ▼

Description : \*  
(max 2000 characters)Attachment : \*  
(copy of resolution)**Note :**

Uploaded file name will be changed by suffixing time-stamp with the actual file name as

**filenameyyyyMMddmmsstt**

Browse...

(Click 'Browse' to select file for attachment)

### Persons signing the resolution

Please indicate the directors/ secretaries who signed the resolution :

- S0036442H / OW CHIN HOCK
- S0070715E / NG KEE CHOE
- S0234645A / CHEW CHOON SENG
- S1001765C / BARRY HENRY PATRICK DESKER
- S1069567H / TAN JIAK NGEE MICHAEL
- S1673157I / YIP WAI PING ANNABELLE
- S1852301I / HONG HAI @ HUANG HAI
- S2163476Z / CHENG WAI WING EDMUND
- S2580327B / RICHARD CHARLES HELFER

Please enter  
names of other  
corporate  
representatives  
who signed the  
resolution, if  
applicable :

### Declaration

I, LIM HONG ENG SUSANNA, Professional body/service bureau, declare the information which has been submitted herein to be true to the best of my knowledge.

**Return of Allotment of Shares****Submit**

Please fill in the following information. Fields marked \* must be completed.

Resolution / Declaration	Share payable in cash	For a consideration other than cash	Share Capital / Allottees Particulars	List of Shareholders after the Allotment	Summary of Capital
--------------------------	-----------------------	-------------------------------------	---------------------------------------	--	--------------------

**Authorised Capital**

	Amount	Nominal Value per Share	Currency
Authorised Capital :	<b>20000000</b>	<b>.1</b>	<b>SINGAPORE DOLLAR ( 099 )</b>

Description of discrepancy :

**Return of Allotment of Shares (Payable in cash) \***

Applicable only if share is payable in cash

Class of Shares :	Ordinary	Preference	Others
Number of shares :	70100		
Amount paid or due and payable on each share			
paid :	0.10		
due and payable :	0		
Amount of premium paid or payable on each share :	1.50		

**Save****Delete Issued Share****Reset****Back**

**Return of Allotment of Shares**

Submit

Please fill in the following information. Fields marked \* must be completed.

Resolution / Declaration	Share payable in cash	For a consideration other than cash	Share Capital / Allottees Particulars	List of Shareholders after the allotment	Summary of Capital
--------------------------	-----------------------	-------------------------------------	---------------------------------------	--	--------------------

**Particulars of Allottee**

Please indicate whether the allottee is an Individual : \*

- Allottee is an Individual  
 Allottee is NOT an Individual

If Allottee is an Individual :

Shareholder Category : \* **Individual**

Identification No. : \*

Retrieve Details

Identification Type : \*

NRIC 

Name : \*

Nationality : \*

Mobile No :

Occupation :

Email Address :

Address Type : \*

- Local  
 Foreign

Local Address (\* if Address Type is Local Address)

Postal Code :

Retrieve Address

Block/House No. :

Street Name :

Unit : #

 - 

Building/Estate Name :

Foreign Address (\* if Address Type is Foreign Address)

Address :

If Allottee is NOT an Individual :

Shareholder Category : \*

Company / Foreign Branch 

Search

Name : **THE CENTRAL DEPOSITORY (PTE) LIMITED**Address Type : **Local**

Local Address (\* if Address Type is Local Address)

Postal Code : **068804**Block/House No. : **2**Street Name : **SHENTON WAY**Unit : # **19 - 00**Building/Estate Name : **SGX CENTRE I**

Foreign Address (\* if Address Type is Foreign Address)

Address :

**Details of Shares Allotted** \* Please read instructions carefully before entering.

Note : If any share or shares is/are co-owned by 2 or more persons, please assign an alphabet e.g. A to denote the Group and enter the same in the box. Enter the same alphabet in the box for every allottee in the same group. Skip this box if share(s) are owned by only one person.

Group of Share that is co-owned:  
(Share Group)

If share(s) is/are co-owned, only one allottee is to enter details in (a), (b), (c), (d) and (e). Enter "0" (zero) for subsequent allottees in box (b) and leave blank for rest of the items.

a) Nominal Value per Share :

b) No. of shares allotted :

c) Class of shares allotted :

d) Currency :

e) Date of allotment :

 (dd/mm/yyyy)

**LOCAL COMPANY TRANSACTIONS**

[HOME](#)   [LOGOUT](#)

**Return of Allotment of Shares**

[Submit](#)

Please fill in the following information. Fields marked \* must be completed.

Resolution / Declaration	Share payable in cash	For a consideration other than cash	Share Capital / Allottees Particulars	List of Shareholders after Allotment	Summary of Capital
--------------------------	-----------------------	-------------------------------------	---------------------------------------	--------------------------------------	--------------------

**List of Allottees and their particulars**

**Identification**

No./Registration No.	Name	Shareholder Category
198003912M	THE CENTRAL DEPOSITORY (PTE) LIMITED	Company / Foreign Branch

If No. of shareholders exceeds 50, total No. of issued shares held by the remaining shareholders are :

No. of Shares	Ordinary	Preference	Others
	0	0	0

**Return of Allotment of Shares**

Please fill in the following information. Fields marked \* must be completed.

<u>Resolution / Declaration</u>	<u>Share payable in cash</u>	<u>For a consideration other than cash</u>	<u>Share Capital / Allottees Particulars</u>	<u>List of Shareholders after the allotment</u>	<u>Summary of Capital</u>
-------------------------------------	----------------------------------	--	--	---	-------------------------------

**Share Capital (1)**

Currency :	<b>SINGAPORE DOLLAR (099)</b>		
Nominal Value per Share :	<b>0.10</b>		
Amount of Authorised Share Capital :	<b>200000000.00</b>		
Class of Shares :	Ordinary	Preference	Others
Amount of Issued Share Capital :	<b>102445947.50</b>	<b>0.00</b>	<b>0.00</b>
Amount of Paid-up Share Capital :	<b>102445947.50</b>	<b>0.00</b>	<b>0.00</b>

**RECEIPT**

Receipt No : ACR0000000887796A

Date/Time : 11/10/2004 12:22

Transaction  
No : C040461171

Agency : RCB - RCB

Application : BIZFILE PAYMENT SERVICE

Paid via : Deposit Service Account

EP Ref No :

**SINGAPORE AIRPORT TERMINAL SERVICES LIMITED**  
**20 AIRPORT BOULEVARD**  
**SATS INFLIGHT CATERING CENTRE 3**  
**SINGAPORE 819659**

---

<b>Sno Code/Description</b>	<b>Unit Price (S\$)</b>	<b>Qty</b>	<b>Amount</b>
1 Lodgment Of Return Of Allotment Of Share <b>COMPANY NAME :</b> 197201770G / SINGAPORE AIRPORT TERMINAL SERVICES LIMITED	10.00	1	10.00
<b>Total (S\$) :</b>			<b>10.00</b>

---

**Deposit Service Account No. : 030066**  
**Balance Amount in Deposit Account : \$ 425.00**

This is a computer-generated receipt. No signature is required.

Please print a copy of the receipt for your reference.

[HOME](#)[LOGOUT](#)



**LOCAL COMPANY TRANSACTIONS****Return of Allotment of Shares****Submit**

Please fill in the following information. Fields marked \* must be completed.

Resolution/Declaration	Shares payable in cash	For a consideration other than cash	Share Capital/Allottees Particulars	List of Shareholders after the allotment	Summary of Capital
------------------------	------------------------	-------------------------------------	-------------------------------------	--	--------------------

**Record saved successfully.****Company Type**

Please click on appropriate button :

- company is listed on the securities exchange
- company is an unlisted public company
- company is a private company

**Power under Section 161 of the Companies Act \***

The directors have obtained the approval of the company in  Yes  No general meeting to issue shares.

**Resolution Made**

\* You are only required to fill in this section if the directors are not given the power under Section 161 of the Companies Act to issue shares.

Registration No. : **197201770G**Company Name : **SINGAPORE AIRPORT TERMINAL SERVICES LIMITED**Nature of Meeting : \* **Directors** ▼Place of Meeting : \*  
  
Date of Meeting : \*  (dd/mm/yyyy)Resolution Type : \* **Director's** ▼Description : \*  
(max 2000 characters)  
Attachment : \*  
(copy of resolution)**Note :**  **Browse...**

Uploaded file name will be changed by suffixing time-stamp with the actual file name as

**filenameyyyyMMddmmsstt**

### Persons signing the resolution

Please indicate the directors/ secretaries who signed the resolution :

- S0036442H / OW CHIN HOCK
- S0070715E / NG KEE CHOE
- S0234645A / CHEW CHOON SENG
- S1001765C / BARRY HENRY PATRICK DESKER
- S1069567H / TAN JIAK NGEER MICHAEL
- S1673157I / YIP WAI PING ANNABELLE
- S1852301I / HONG HAI @ HUANG HAI
- S2163476Z / CHENG WAI WING EDMUND
- S2580327B / RICHARD CHARLES HELFER

Please enter  
names of other  
corporate  
representatives  
who signed the  
resolution, if  
applicable :

### Declaration

I, LIM HONG ENG SUSANNA, Professional body/service bureau, declare the information which has been submitted herein to be true to the best of my knowledge.

**Return of Allotment of Shares**

Submit

Please fill in the following information. Fields marked \* must be completed.

Resolution / Declaration	Share payable in cash	For a consideration other than cash	Share Capital / Allottees Particulars	List of Shareholders after the Allotment	Summary of Capital
--------------------------	-----------------------	-------------------------------------	---------------------------------------	--	--------------------

**Authorised Capital**

	Amount	Nominal Value per Share	Currency
Authorised Capital :	<b>20000000</b>	<b>.1</b>	<b>SINGAPORE DOLLAR ( 099 )</b>

Description of discrepancy :

**Return of Allotment of Shares (Payable in cash) \***

Applicable only if share is payable in cash

Class of Shares :	Ordinary	Preference	Others
Number of shares :	7800		
Amount paid or due and payable on each share			
paid :	0.10		
due and payable :	0		
Amount of premium paid or payable on each share :	1.14		

Save

Delete Issued Share

Reset

Back

**Return of Allotment of Shares**

Submit

Please fill in the following information. Fields marked \* must be completed.

Resolution / Declaration	Share payable in cash	For a consideration other than cash	Share Capital / Allottees Particulars	List of Shareholders after the allotment	Summary of Capital
-----------------------------	--------------------------	---	---	---	-----------------------

**Particulars of Allottee**

Please indicate whether the allottee is an Individual : \*

- Allottee is an Individual  
 Allottee is NOT an Individual

If Allottee is an Individual :

Shareholder Category : \* **Individual**Identification No. : \*  Retrieve DetailsIdentification Type : \* Name : \* Nationality : \* Mobile No : Occupation : Email Address : Address Type : \*  
 Local  
 Foreign

Local Address (\* if Address Type is Local Address)

Postal Code :  Retrieve AddressBlock/House No. : Street Name : Unit : #  - Building/Estate Name : 

Foreign Address (\* if Address Type is Foreign Address)

Address : 

If Allottee is NOT an Individual :

Shareholder Category : \*  Search

Name : THE CENTRAL DEPOSITORY (PTE) LIMITED

Address Type : Local

Local Address (\* if Address Type is Local Address)

Postal Code : 068804

Block/House No. : 2

Street Name : SHENTON WAY

Unit : # 19 - 00

Building/Estate Name : SGX CENTRE I

Foreign Address (\* if Address Type is Foreign Address)

Address :

**Details of Shares Allotted** \* Please read instructions carefully before entering.

Note : If any share or shares is/are co-owned by 2 or more persons, please assign an alphabet e.g. A to denote the Group and enter the same in the box. Enter the same alphabet in the box for every allottee in the same group. Skip this box if share(s) are owned by only one person.

Group of Share that is co-owned:  (Share Group)

If share(s) is/are co-owned, only one allottee is to enter details in (a), (b), (c), (d) and (e). Enter "0" (zero) for subsequent allottees in box (b) and leave blank for rest of the items.

a) Nominal Value per Share :

b) No. of shares allotted :

c) Class of shares allotted :

d) Currency :

e) Date of allotment :  (dd/mm/yyyy)

**Return of Allotment of Shares****Submit**

Please fill in the following information. Fields marked \* must be completed.

<b>Resolution / Declaration</b>	<b>Share payable in cash</b>	<b>For a consideration other than cash</b>	<b>Share Capital / Allottees Particulars</b>	<b>List of Shareholders after Allotment</b>	<b>Summary of Capital</b>
-------------------------------------	----------------------------------	--	--	---	-------------------------------

**List of Allottees and their particulars****Identification****No./Registration Name****Shareholder Category****No.**

198003912M	THE CENTRAL DEPOSITORY (PTE) LIMITED	Company / Foreign Branch
------------	---	--------------------------

If No. of shareholders exceeds 50, total No. of issued shares held by the remaining shareholders are :

	<b>Ordinary</b>	<b>Preference</b>	<b>Others</b>
<b>No. of Shares</b>	<b>0</b>	<b>0</b>	<b>0</b>

**Return of Allotment of Shares****Submit**

Please fill in the following information. Fields marked \* must be completed.

<u>Resolution / Declaration</u>	<u>Share payable in cash</u>	<u>For a consideration other than cash</u>	<u>Share Capital / Allottees Particulars</u>	<u>List of Shareholders after the allotment</u>	<u>Summary of Capital</u>
---------------------------------	------------------------------	--	--	---	---------------------------

**Share Capital (1)**

Currency :	<b>SINGAPORE DOLLAR (099)</b>		
Nominal Value per Share :	<b>0.10</b>		
Amount of Authorised Share Capital :	<b>200000000.00</b>		
Class of Shares :	Ordinary	Preference	Others
Amount of Issued Share Capital :	<b>102438937.50</b>	<b>0.00</b>	<b>0.00</b>
Amount of Paid-up Share Capital :	<b>102438937.50</b>	<b>0.00</b>	<b>0.00</b>

✓

GST No. :M9-0008879-T

**RECEIPT**

Receipt No : ACR0000000887257A

Date/Time : 11/10/2004 09:42

Transaction  
No : C040460612

Agency : RCB - RCB

Application : BIZFILE PAYMENT SERVICE

Paid via : Deposit Service Account

EP Ref No :

**SINGAPORE AIRPORT TERMINAL SERVICES LIMITED****20 AIRPORT BOULEVARD****SATS INFLIGHT CATERING CENTRE 3****SINGAPORE 819659**

Sno	Code/Description	Unit Price (S\$)	Qty	Amount
1	Lodgment Of Return Of Allotment Of Share <b>COMPANY NAME :</b> 197201770G / SINGAPORE AIRPORT TERMINAL SERVICES LIMITED	10.00	1	10.00
			Total (S\$) :	10.00

**Deposit Service Account No. : 030066**  
**Balance Amount in Deposit Account : \$ 435.00**

This is a computer-generated receipt. No signature is required.

Please print a copy of the receipt for your reference.

[HOME](#)[LOGOUT](#)



**Return of Allotment of Shares****Submit**

Please fill in the following information. Fields marked \* must be completed.

Resolution/Declaration	Shares payable in cash	For a consideration other than cash	Share Capital/Allottees Particulars	List of Shareholders after the allotment	Summary of Capital
------------------------	------------------------	-------------------------------------	-------------------------------------	--	--------------------

**Record saved successfully.****Company Type**

Please click on appropriate button :

- company is listed on the securities exchange
- company is an unlisted public company
- company is a private company

**Power under Section 161 of the Companies Act \***

The directors have obtained the approval of the company in general meeting to issue shares.

Yes  No

**Resolution Made**

\* You are only required to fill in this section if the directors are not given the power under Section 161 of the Companies Act to issue shares.

Registration No. : **197201770G**Company Name : **SINGAPORE AIRPORT TERMINAL SERVICES LIMITED**Nature of Meeting : \* **Directors** ▼Place of Meeting : \*  
  
Date of Meeting : \*  (dd/mm/yyyy)Resolution Type : \* **Director's** ▼Description : \*  
(max 2000 characters)  
Attachment : \*  
(copy of resolution)**Note :**  **Browse...**

Uploaded file name will be changed by suffixing time-stamp with the actual file name as

(Click 'Browse' to select file for attachment)

**filenameyyyyMMddmmsstt**

**Persons signing the resolution**

Please indicate the directors/ secretaries who signed the resolution :

- S0036442H / OW CHIN HOCK
- S0070715E / NG KEE CHOE
- S0234645A / CHEW CHOON SENG
- S1001765C / BARRY HENRY PATRICK DESKER
- S1069567H / TAN JIAK NGEE MICHAEL
- S1673157I / YIP WAI PING ANNABELLE
- S1852301I / HONG HAI @ HUANG HAI
- S2163476Z / CHENG WAI WING EDMUND
- S2580327B / RICHARD CHARLES HELFER

Please enter names of other corporate representatives who signed the resolution, if applicable :

**Declaration**

I, LIM HONG ENG SUSANNA, Professional body/service bureau, declare the information which has been submitted herein to be true to the best of my knowledge.

**Return of Allotment of Shares**

Submit

Please fill in the following information. Fields marked \* must be completed.

<b>Resolution / Declaration</b>	<b>Share payable in cash</b>	<b>For a consideration other than cash</b>	<b>Share Capital / Allottees Particulars</b>	<b>List of Shareholders after the Allotment</b>	<b>Summary of Capital</b>
-------------------------------------	----------------------------------	--	--	---	-------------------------------

**Authorised Capital**

	<b>Amount</b>	<b>Nominal Value per Share</b>	<b>Currency</b>
Authorised Capital :	<b>200000000</b>	<b>.1</b>	<b>SINGAPORE DOLLAR ( 099 )</b>

Description of discrepancy :

**Return of Allotment of Shares (Payable in cash) \***

Applicable only if share is payable in cash

<b>Class of Shares :</b>	<b>Ordinary</b>	<b>Preference</b>	<b>Others</b>
Number of shares :	<input type="text" value="16200"/>	<input type="text"/>	<input type="text"/>
Amount paid or due and payable on each share			
paid :	<input type="text" value="0.10"/>	<input type="text"/>	<input type="text"/>
due and payable :	<input type="text" value="0"/>	<input type="text"/>	<input type="text"/>
Amount of premium paid or payable on each share :	<input type="text" value="1.70"/>	<input type="text"/>	<input type="text"/>

Save

Delete Issued Share

Reset

Back

**Return of Allotment of Shares**

Submit

Please fill in the following information. Fields marked \* must be completed.

Resolution / Declaration	Share payable in cash	For a consideration other than cash	Share Capital / Allottees Particulars	List of Shareholders after the allotment	Summary of Capital
--------------------------	-----------------------	-------------------------------------	---------------------------------------	--	--------------------

**Particulars of Allottee**

Please indicate whether the allottee is an Individual : \*

- Allottee is an Individual  
 Allottee is NOT an Individual

If Allottee is an Individual :

Shareholder Category : \* **Individual**Identification No. : \*  Retrieve DetailsIdentification Type : \* Name : \* Nationality : \* Mobile No : Occupation : Email Address : Address Type : \*  
 Local  
 Foreign

Local Address (\* if Address Type is Local Address)

Postal Code :  Retrieve AddressBlock/House No. : Street Name : Unit : #  - Building/Estate Name : 

Foreign Address (\* if Address Type is Foreign Address)

Address : 

If Allottee is NOT an Individual :

Shareholder Category : \*  Search

Registration No. : \*

198003912M

Retrieve Details

Name :

**THE CENTRAL DEPOSITORY (PTE) LIMITED**

Address Type :

**Local**

Local Address (\* if Address Type is Local Address)

Postal Code : **068804**

Block/House No. : **2**

Street Name : **SHENTON WAY**

Unit : # **19 - 00**

Building/Estate Name : **SGX CENTRE I**

Foreign Address (\* if Address Type is Foreign Address)

Address :

**Details of Shares Allotted** \* Please read instructions carefully before entering.

Note : If any share or shares is/are co-owned by 2 or more persons, please assign an alphabet e.g. A to denote the Group and enter the same in the box. Enter the same alphabet in the box for every allottee in the same group. Skip this box if share(s) are owned by only one person.

Group of Share that is co-owned:  
(Share Group)

If share(s) is/are co-owned, only one allottee is to enter details in (a), (b), (c), (d) and (e). Enter "0" (zero) for subsequent allottees in box (b) and leave blank for rest of the items.

a) Nominal Value per Share :

0.10 ✓

b) No. of shares allotted :

16200 ✓

c) Class of shares allotted :

Ordinary ▼ ✓

d) Currency :

SINGAPORE DOLLAR (099) ▼

e) Date of allotment :

04/10/2004 (dd/mm/yyyy)

Save

Reset

Back

**Return of Allotment of Shares****Submit**

Please fill in the following information. Fields marked \* must be completed.

<b>Resolution / Declaration</b>	<b>Share payable in cash</b>	<b>For a consideration other than cash</b>	<b>Share Capital / Allotees Particulars</b>	<b>List of Shareholders after Allotment</b>	<b>Summary of Capital</b>
-------------------------------------	----------------------------------	--	---	---	-------------------------------

**List of Allotees and their particulars****Identification****No./Registration Name  
No.****Shareholder Category**

198003912M	THE CENTRAL DEPOSITORY (PTE) LIMITED	Company / Foreign Branch
------------	---	--------------------------

If No. of shareholders exceeds 50, total No. of issued shares held by the remaining shareholders are :

	<b>Ordinary</b>	<b>Preference</b>	<b>Others</b>
<b>No. of Shares</b>	0	0	0

**Return of Allotment of Shares****Submit**

Please fill in the following information. Fields marked \* must be completed.

Resolution / Declaration	Share payable in cash	For a consideration other than cash	Share Capital / Allottees Particulars	List of Shareholders after the allotment	Summary of Capital
--------------------------	-----------------------	-------------------------------------	---------------------------------------	--	--------------------

**Share Capital (1)**

Currency :	<b>SINGAPORE DOLLAR (099)</b>		
Nominal Value per Share :	<b>0.10</b>		
Amount of Authorised Share Capital :	<b>200000000.00</b>		
Class of Shares :	Ordinary	Preference	Others
Amount of Issued Share Capital :	<b>102438157.50</b>	<b>0.00</b>	<b>0.00</b>
Amount of Paid-up Share Capital :	<b>102438157.50</b>	<b>0.00</b>	<b>0.00</b>

**RECEIPT**

Receipt No : ACR0000000885916A

Date/Time : 08/10/2004 14:45

Transaction No : C040459055

Agency : RCB - RCB

Application : BIZFILE PAYMENT SERVICE

Paid via : Deposit Service Account

EP Ref No :

**SINGAPORE AIRPORT TERMINAL SERVICES LIMITED  
20 AIRPORT BOULEVARD  
SATS INFLIGHT CATERING CENTRE 3  
SINGAPORE 819659**

<b>Sno Code/Description</b>	<b>Unit Price (S\$)</b>	<b>Qty</b>	<b>Amount</b>
1 Lodgment Of Return Of Allotment Of Share <b>COMPANY NAME :</b> 197201770G / SINGAPORE AIRPORT TERMINAL SERVICES LIMITED	10.00	1	10.00
<b>Total (S\$) :</b>			10.00

**Deposit Service Account No. : 030066**  
**Balance Amount in Deposit Account : \$ 445.00**

This is a computer-generated receipt. No signature is required.

Please print a copy of the receipt for your reference.

[HOME](#)[LOGOUT](#)



**Return of Allotment of Shares****Submit**

Please fill in the following information. Fields marked \* must be completed.

Resolution/Declaration	Shares payable in cash	For a consideration other than cash	Share Capital/Allottees Particulars	List of Shareholders after the allotment	Summary of Capital
------------------------	---------------------------	---	---	---	-----------------------

**Record saved successfully.****Company Type**

Please click on appropriate button :

- company is listed on the securities exchange  
 company is an unlisted public company  
 company is a private company

**Power under Section 161 of the Companies Act \***

The directors have obtained  
the approval of the company in  Yes  
general meeting to issue  No  
shares.

**Resolution Made**

\* You are only required to fill in this section if the directors are not given the power under Section 161 of the Companies Act to issue shares.

Registration No. : **197201770G**Company Name : **SINGAPORE AIRPORT TERMINAL SERVICES LIMITED**Nature of Meeting : \*  ▼

Place of Meeting : \*

Date of Meeting: \*  (dd/mm/yyyy)Resolution Type : \*  ▼Description : \*  
(max 2000 characters)Attachment : \*  
(copy of resolution)**Note :**

Uploaded file name will be  
changed by suffixing time-  
stamp with the actual file  
name as

**filenameyyyyMMddmmsstt****Browse...**

(Click 'Browse' to select file for attachment)

**Persons signing the resolution**

Please indicate the directors/ secretaries who signed the resolution :

- S0036442H / OW CHIN HOCK
- S0070715E / NG KEE CHOE
- S0234645A / CHEW CHOON SENG
- S1001765C / BARRY HENRY PATRICK DESKER
- S1069567H / TAN JIAK NGEE MICHAEL
- S1673157I / YIP WAI PING ANNABELLE
- S1852301I / HONG HAI @ HUANG HAI
- S2163476Z / CHENG WAI WING EDMUND
- S2580327B / RICHARD CHARLES HELFER

Please enter names of other corporate representatives who signed the resolution, if applicable :

**Declaration**

I, LIM HONG ENG SUSANNA, Professional body/service bureau, declare the information which has been submitted herein to be true to the best of my knowledge.

**Return of Allotment of Shares**[Submit](#)

Please fill in the following information. Fields marked \* must be completed.

Resolution / Declaration	Share payable in cash	For a consideration other than cash	Share Capital / Allottees Particulars	List of Shareholders after the Allotment	Summary of Capital
--------------------------	-----------------------	-------------------------------------	---------------------------------------	--	--------------------

**Authorised Capital**

	Amount	Nominal Value per Share	Currency
Authorised Capital :	<b>200000000</b>	<b>.1</b>	<b>SINGAPORE DOLLAR ( 099 )</b>

Description of discrepancy :

**Return of Allotment of Shares (Payable in cash) \***

Applicable only if share is payable in cash

Class of Shares :	Ordinary	Preference	Others
Number of shares :	<input type="text" value="96200"/>	<input type="text"/>	<input type="text"/>
Amount paid or due and payable on each share			
paid :	<input type="text" value="0.10"/>	<input type="text"/>	<input type="text"/>
due and payable :	<input type="text" value="0"/>	<input type="text"/>	<input type="text"/>
Amount of premium paid or payable on each share :	<input type="text" value="1.50"/>	<input type="text"/>	<input type="text"/>

[Save](#)
[Delete Issued Share](#)
[Reset](#)
[Back](#)

**Return of Allotment of Shares****Submit**

Please fill in the following information. Fields marked \* must be completed.

<u>Resolution / Declaration</u>	<u>Share payable in cash</u>	<u>For a consideration other than cash</u>	<u>Share Capital / Allottees Particulars</u>	<u>List of Shareholders after the allotment</u>	<u>Summary of Capital</u>
---------------------------------	------------------------------	--	--	---	---------------------------

**Particulars of Allottee**

Please indicate whether the allottee is an Individual : \*

- Allottee is an Individual  
 Allottee is NOT an Individual

If Allottee is an Individual :

Shareholder Category : \* **Individual**

Identification No. : \*

**Retrieve Details**

Identification Type : \*

NRIC

Name : \*

Nationality : \*

Mobile No :

Occupation :

Email Address :

Address Type : \*

- Local  
 Foreign

Local Address (\* if Address Type is Local Address)

Postal Code :

**Retrieve Address**

Block/House No. :

Street Name :

Unit : #

 - 

Building/Estate Name :

Foreign Address (\* if Address Type is Foreign Address)

Address :

If Allottee is NOT an Individual :

Shareholder Category : \*

Company / Foreign Branch**Search**

Name : **THE CENTRAL DEPOSITORY (PTE) LIMITED**Address Type : **Local**

Local Address (\* if Address Type is Local Address)

Postal Code : **068804**Block/House No. : **2**Street Name : **SHENTON WAY**Unit : # **19 - 00**Building/Estate Name : **SGX CENTRE I**

Foreign Address (\* if Address Type is Foreign Address)

Address :

**Details of Shares Allotted** \* Please read instructions carefully before entering.

Note : If any share or shares is/are co-owned by 2 or more persons, please assign an alphabet e.g. A to denote the Group and enter the same in the box. Enter the same alphabet in the box for every allottee in the same group. Skip this box if share(s) are owned by only one person.

Group of Share that is co-owned:  
(Share Group) 

If share(s) is/are co-owned, only one allottee is to enter details in (a), (b), (c), (d) and (e). Enter "0" (zero) for subsequent allottees in box (b) and leave blank for rest of the items.

a) Nominal Value per Share : b) No. of shares allotted : c) Class of shares allotted : d) Currency : e) Date of allotment :  (dd/mm/yyyy)

**Return of Allotment of Shares****Submit**

Please fill in the following information. Fields marked \* must be completed.

<b>Resolution / Declaration</b>	<b>Share payable in cash</b>	<b>For a consideration other than cash</b>	<b>Share Capital / Allottees Particulars</b>	<b>List of Shareholders after Allotment</b>	<b>Summary of Capital</b>
-------------------------------------	----------------------------------	--	--	---	-------------------------------

**List of Allottees and their particulars****Identification****No./Registration Name  
No.****Shareholder Category**

198003912M	THE CENTRAL DEPOSITORY (PTE) LIMITED	Company / Foreign Branch
------------	---	--------------------------

If No. of shareholders exceeds 50, total No. of issued shares held by the remaining shareholders are :

	<b>Ordinary</b>	<b>Preference</b>	<b>Others</b>
<b>No. of Shares</b>	0	0	0

**Return of Allotment of Shares****Submit**

Please fill in the following information. Fields marked \* must be completed.

Resolution / Declaration	Share payable in cash	For a consideration other than cash	Share Capital / Allottees Particulars	List of Shareholders after the allotment	Summary of Capital
--------------------------	-----------------------	-------------------------------------	---------------------------------------	--	--------------------

**Share Capital (1)**

Currency :	<b>SINGAPORE DOLLAR (099)</b>		
Nominal Value per Share :	<b>0.10</b>		
Amount of Authorised Share Capital :	<b>200000000.00</b>		
Class of Shares :	Ordinary	Preference	Others
Amount of Issued Share Capital :	<b>102436537.50</b>	<b>0.00</b>	<b>0.00</b>
Amount of Paid-up Share Capital :	<b>102436537.50</b>	<b>0.00</b>	<b>0.00</b>

✓

GST No. :M9-0008879-T

**RECEIPT**

Receipt No : ACR0000000885255A

Date/Time : 08/10/2004 10:36

Transaction No : C040458418

Agency : RCB - RCB

Application : BIZFILE PAYMENT SERVICE

Paid via : Deposit Service Account

EP Ref No :

**SINGAPORE AIRPORT TERMINAL SERVICES LIMITED  
20 AIRPORT BOULEVARD  
SATS INFLIGHT CATERING CENTRE 3  
SINGAPORE 819659**

<b>Sno Code/Description</b>	<b>Unit Price (S\$)</b>	<b>Qty</b>	<b>Amount</b>
1 Lodgment Of Return Of Allotment Of Share <b>COMPANY NAME :</b> 197201770G / SINGAPORE AIRPORT TERMINAL SERVICES LIMITED	10:00	1	10.00
<b>Total (S\$) :</b>			<b>10.00</b>

**Deposit Service Account No. : 030066**  
**Balance Amount in Deposit Account : \$ 455.00**

This is a computer-generated receipt. No signature is required.

Please print a copy of the receipt for your reference.

[HOME](#)[LOGOUT](#)



**Return of Allotment of Shares**

Submit

Please fill in the following information. Fields marked \* must be completed.

Resolution/Declaration	Shares payable in cash	For a consideration <u>other than cash</u>	Share Capital/Allottees Particulars	List of Shareholders after the allotment	Summary of Capital
------------------------	---------------------------	--	---	---	-----------------------

**Record saved successfully.****Company Type**

Please click on appropriate button :

- company is listed on the securities exchange  
 company is an unlisted public company  
 company is a private company

**Power under Section 161 of the Companies Act \***

The directors have obtained  
the approval of the company in  Yes  
general meeting to issue  No  
shares.

**Resolution Made**

\* You are only required to fill in this section if the directors are not given the power under Section 161 of the Companies Act to issue shares.

Registration No. : **197201770G**Company Name : **SINGAPORE AIRPORT TERMINAL SERVICES LIMITED**Nature of Meeting : \* Directors 

Place of Meeting : \*

Date of Meeting : \*  (dd/mm/yyyy)Resolution Type : \* Director's Description : \*  
(max 2000 characters)Attachment : \*  
(copy of resolution)**Note :**Uploaded file name will be  
changed by suffixing time-  
stamp with the actual file  
name as

filenameyyyyMMddmmsstt

Browse...

(Click 'Browse' to select file for attachment)

### Persons signing the resolution

Please indicate the directors/ secretaries who signed the resolution :

- S0036442H / OW CHIN HOCK
- S0070715E / NG KEE CHOE
- S0234645A / CHEW CHOON SENG
- S1001765C / BARRY HENRY PATRICK DESKER
- S1069567H / TAN JIAK NGEE MICHAEL
- S1673157I / YIP WAI PING ANNABELLE
- S1852301I / HONG HAI @ HUANG HAI
- S2163476Z / CHENG WAI WING EDMUND
- S2580327B / RICHARD CHARLES HELFER

Please enter  
names of other  
corporate  
representatives  
who signed the  
resolution, if  
applicable :

### Declaration

I, LIM HONG ENG SUSANNA, Professional body/service bureau, declare the information which has been submitted herein to be true to the best of my knowledge.

**Return of Allotment of Shares**

[Submit](#)

Please fill in the following information. Fields marked \* must be completed.

<u>Resolution / Declaration</u>	<u>Share payable in cash</u>	<u>For a consideration other than cash</u>	<u>Share Capital / Allottees Particulars</u>	<u>List of Shareholders after the Allotment</u>	<u>Summary of Capital</u>
---------------------------------	------------------------------	--	--	---	---------------------------

**Authorised Capital**

	Amount	Nominal Value per Share	Currency
Authorised Capital :	<b>200000000</b>	<b>.1</b>	<b>SINGAPORE DOLLAR ( 099 )</b>

Description of discrepancy :

**Return of Allotment of Shares (Payable in cash) \***

Applicable only if share is payable in cash

Class of Shares :	Ordinary	Preference	Others
Number of shares :	<input type="text" value="41600"/>	<input type="text"/>	<input type="text"/>
Amount paid or due and payable on each share			
paid :	<input type="text" value="0.10"/>	<input type="text"/>	<input type="text"/>
due and payable :	<input type="text" value="0"/>	<input type="text"/>	<input type="text"/>
Amount of premium paid or payable on each share :	<input type="text" value="1.14"/>	<input type="text"/>	<input type="text"/>

[Save](#)   [Delete Issued Share](#)   [Reset](#)   [Back](#)

**Return of Allotment of Shares**[Submit](#)

Please fill in the following information. Fields marked \* must be completed.

Resolution / Declaration	Share payable in cash	For a consideration other than cash	Share Capital / Allottees Particulars	List of Shareholders after the allotment	Summary of Capital
-----------------------------	--------------------------	---	---	---	-----------------------

**Particulars of Allottee**

Please indicate whether the allottee is an Individual : \*

- Allottee is an Individual  
 Allottee is NOT an Individual

If Allottee is an Individual :

Shareholder Category : \* **Individual**Identification No. : \*  [Retrieve Details](#)Identification Type : \* Name : \* Nationality : \* Mobile No : Occupation : Email Address : Address Type : \*  Local  
 Foreign

Local Address (\* if Address Type is Local Address)

Postal Code :  [Retrieve Address](#)Block/House No. : Street Name : Unit : #  - Building/Estate Name : 

Foreign Address (\* if Address Type is Foreign Address)

Address :   

If Allottee is NOT an Individual :

Shareholder Category : \*  [Search](#)

Registration No. : \*

198003912M

Retrieve Details

Name : **THE CENTRAL DEPOSITORY (PTE) LIMITED**

Address Type : **Local**

Local Address (\* if Address Type is Local Address)

Postal Code : **068804**

Block/House No. : **2**

Street Name : **SHENTON WAY**

Unit : # **19 - 00**

Building/Estate Name : **SGX CENTRE I**

Foreign Address (\* if Address Type is Foreign Address)

Address :

**Details of Shares Allotted** \* Please read instructions carefully before entering.

Note : If any share or shares is/are co-owned by 2 or more persons, please assign an alphabet e.g. A to denote the Group and enter the same in the box. Enter the same alphabet in the box for every allottee in the same group. Skip this box if share(s) are owned by only one person.

Group of Share that is co-owned:  
(Share Group)

If share(s) is/are co-owned, only one allottee is to enter details in (a), (b), (c), (d) and (e). Enter "0" (zero) for subsequent allottees in box (b) and leave blank for rest of the items.

- a) Nominal Value per Share :  ✓
- b) No. of shares allotted :  ✓
- c) Class of shares allotted :  ✓
- d) Currency :  ✓
- e) Date of allotment :  (dd/mm/yyyy) ✓

**Return of Allotment of Shares****Submit**

Please fill in the following information. Fields marked \* must be completed.

<b>Resolution / Declaration</b>	<b>Share payable in cash</b>	<b>For a consideration other than cash</b>	<b>Share Capital / Allottees Particulars</b>	<b>List of Shareholders after Allotment</b>	<b>Summary of Capital</b>
-------------------------------------	----------------------------------	--	--	---	-------------------------------

**List of Allottees and their particulars****Identification****No./Registration Name  
No.****Shareholder Category**

198003912M	THE CENTRAL DEPOSITORY (PTE) LIMITED	Company / Foreign Branch
------------	---	--------------------------

If No. of shareholders exceeds 50, total No. of issued shares held by the remaining shareholders are :

	<b>Ordinary</b>	<b>Preference</b>	<b>Others</b>
<b>No. of Shares</b>	<b>0</b>	<b>0</b>	<b>0</b>

**Return of Allotment of Shares****Submit**

Please fill in the following information. Fields marked \* must be completed.

Resolution / Declaration	Share payable in cash	For a consideration other than cash	Share Capital / Allottees Particulars	List of Shareholders after the allotment	Summary of Capital
-----------------------------	--------------------------	---	---	---	-----------------------

**Share Capital (1)**

Currency :	<b>SINGAPORE DOLLAR (099)</b>		
Nominal Value per Share :	<b>0.10</b>		
Amount of Authorised Share Capital :	<b>200000000.00</b>		
Class of Shares :	Ordinary	Preference	Others
Amount of Issued Share Capital :	<b>102426917.50</b>	<b>0.00</b>	<b>0.00</b>
Amount of Paid-up Share Capital :	<b>102426917.50</b>	<b>0.00</b>	<b>0.00</b>

✓

GST No. :M9-0008879-T

**RECEIPT**

Receipt No : ACR0000000885206A

Date/Time : 08/10/2004 10:26

Transaction  
No : C040458372

Agency : RCB - RCB

Application : BIZFILE PAYMENT SERVICE

Paid via : Deposit Service Account

EP Ref No :

**SINGAPORE AIRPORT TERMINAL SERVICES LIMITED  
20 AIRPORT BOULEVARD  
SATS INFLIGHT CATERING CENTRE 3  
SINGAPORE 819659**

<b>Sno Code/Description</b>	<b>Unit Price (S\$)</b>	<b>Qty</b>	<b>Amount</b>
1 Lodgment Of Return Of Allotment Of Share <b>COMPANY NAME :</b> 197201770G / SINGAPORE AIRPORT TERMINAL SERVICES LIMITED	10.00	1	10.00
<b>Total (S\$) :</b>			<b>10.00</b>

**Deposit Service Account No. : 030066**  
**Balance Amount in Deposit Account : \$ 465.00**

This is a computer-generated receipt. No signature is required.

Please print a copy of the receipt for your reference.

[HOME](#)[LOGOUT](#)



**Return of Allotment of Shares**

Submit

Please fill in the following information. Fields marked \* must be completed.

Resolution/Declaration	Shares payable in cash	For a consideration other than cash	Share Capital/Allottees Particulars	List of Shareholders after the allotment	Summary of Capital
------------------------	---------------------------	---	---	---	-----------------------

**Record saved successfully.****Company Type**

Please click on appropriate button :

- company is listed on the securities exchange ✓  
 company is an unlisted public company  
 company is a private company

**Power under Section 161 of the Companies Act \***

The directors have obtained the approval of the company in general meeting to issue shares.

Yes (✓)  
 No

**Resolution Made**

\* You are only required to fill in this section if the directors are not given the power under Section 161 of the Companies Act to issue shares.

Registration No. : **197201770G**Company Name : **SINGAPORE AIRPORT TERMINAL SERVICES LIMITED**

Nature of Meeting : \* Directors ▼

Place of Meeting : \*

Date of Meeting : \* (dd/mm/yyyy)

Resolution Type : \* Director's ▼

Description : \*  
(max 2000 characters)Attachment : \*  
(copy of resolution)**Note :**

Uploaded file name will be changed by suffixing time-stamp with the actual file name as

**filenameyyyyMMddmmsstt**

Browse...

(Click 'Browse' to select file for attachment)

**Persons signing the resolution**

Please indicate the directors/ secretaries who signed the resolution :

- S0036442H / OW CHIN HOCK
- S0070715E / NG KEE CHOE
- S0234645A / CHEW CHOON SENG
- S1001765C / BARRY HENRY PATRICK DESKER
- S1069567H / TAN JIAK NGEЕ MICHAEL
- S1673157I / YIP WAI PING ANNABELLE
- S1852301I / HONG HAI @ HUANG HAI
- S2163476Z / CHENG WAI WING EDMUND
- S2580327B / RICHARD CHARLES HELFER

Please enter names of other corporate representatives who signed the resolution, if applicable :

**Declaration**

I, LIM HONG ENG SUSANNA, Professional body/service bureau, declare the information which has been submitted herein to be true to the best of my knowledge.

**Return of Allotment of Shares**

[Submit](#)

Please fill in the following information. Fields marked \* must be completed.

Resolution / Declaration	Share payable in cash	For a consideration other than cash	Share Capital / Allottees Particulars	List of Shareholders after the Allotment	Summary of Capital
--------------------------	-----------------------	-------------------------------------	---------------------------------------	--	--------------------

**Authorised Capital**

	Amount	Nominal Value per Share	Currency
Authorised Capital :	<b>200000000</b>	<b>.1</b>	<b>SINGAPORE DOLLAR ( 099 )</b>

Description of discrepancy :

**Return of Allotment of Shares (Payable in cash) \***

Applicable only if share is payable in cash

Class of Shares :	Ordinary	Preference	Others
Number of shares :	<input type="text" value="96200"/>	<input type="text"/>	<input type="text"/>
Amount paid or due and payable on each share			
paid :	<input type="text" value="0.10"/>	<input type="text"/>	<input type="text"/>
due and payable :	<input type="text" value="0"/>	<input type="text"/>	<input type="text"/>
Amount of premium paid or payable on each share :	<input type="text" value="1.70"/>	<input type="text"/>	<input type="text"/>

[Save](#)   [Delete Issued Share](#)   [Reset](#)   [Back](#)

**Return of Allotment of Shares****Submit**

Please fill in the following information. Fields marked \* must be completed.

<u>Resolution / Declaration</u>	<u>Share payable in cash</u>	<u>For a consideration other than cash</u>	<u>Share Capital / Allottees Particulars</u>	<u>List of Shareholders after the allotment</u>	<u>Summary of Capital</u>
---------------------------------	------------------------------	--	--	---	---------------------------

**Particulars of Allottee****Please indicate whether the allottee is an Individual : \***

- Allottee is an Individual
- Allottee is NOT an Individual

**If Allottee is an Individual :**Shareholder Category : \* **Individual**Identification No. : \*  **Retrieve Details**Identification Type : \* Name : \* Nationality : \* Mobile No : Occupation : Email Address : Address Type : \*  Local  Foreign

Local Address (\* if Address Type is Local Address)

Postal Code :  **Retrieve Address**Block/House No. : Street Name : Unit : #  - Building/Estate Name : 

Foreign Address (\* if Address Type is Foreign Address)

Address :   
**If Allottee is NOT an Individual :**Shareholder Category : \*  **Search**

Registration No. : \*

198003912M

Retrieve Details

Name :

THE CENTRAL DEPOSITORY (PTE) LIMITED

Address Type :

Local

Local Address (\* if Address Type is Local Address)

Postal Code : 068804

Block/House No. : 2

Street Name : SHENTON WAY

Unit : # 19 - 00

Building/Estate Name : SGX CENTRE 1

Foreign Address (\* if Address Type is Foreign Address)

Address :

**Details of Shares Allotted** \* Please read instructions carefully before entering.

Note : If any share or shares is/are co-owned by 2 or more persons, please assign an alphabet e.g. A to denote the Group and enter the same in the box. Enter the same alphabet in the box for every allottee in the same group. Skip this box if share(s) are owned by only one person.

Group of Share that is co-owned:  
(Share Group)

If share(s) is/are co-owned, only one allottee is to enter details in (a), (b), (c), (d) and (e). Enter "0" (zero) for subsequent allottees in box (b) and leave blank for rest of the items.

a) Nominal Value per Share :

0.10

b) No. of shares allotted :

96200

c) Class of shares allotted :

Ordinary

d) Currency :

SINGAPORE DOLLAR (099)

e) Date of allotment :

01/10/2004 (dd/mm/yyyy)

Save

Reset

Back

**Return of Allotment of Shares****Submit**

Please fill in the following information. Fields marked \* must be completed.

<b>Resolution / Declaration</b>	<b>Share payable in cash</b>	<b>For a consideration other than cash</b>	<b>Share Capital / Allottees Particulars</b>	<b>List of Shareholders after Allotment</b>	<b>Summary of Capital</b>
-------------------------------------	----------------------------------	--	--	---	-------------------------------

**List of Allottees and their particulars****Identification****No./Registration Name  
No.****Shareholder Category**

198003912M	THE CENTRAL DEPOSITORY (PTE) LIMITED	Company / Foreign Branch
------------	---	--------------------------

If No. of shareholders exceeds 50, total No. of issued shares held by the remaining shareholders are :

<b>No. of Shares</b>	<b>Ordinary</b>	<b>Preference</b>	<b>Others</b>
	0	0	0

**Return of Allotment of Shares**

Submit

Please fill in the following information. Fields marked \* must be completed.

<u>Resolution / Declaration</u>	<u>Share payable in cash</u>	<u>For a consideration other than cash</u>	<u>Share Capital / Allottees Particulars</u>	<u>List of Shareholders after the allotment</u>	<u>Summary of Capital</u>
-------------------------------------	----------------------------------	--	--	---	-------------------------------

**Share Capital (1)**

Currency :	<b>SINGAPORE DOLLAR (099)</b>		
Nominal Value per Share :	<b>0.10</b>		
Amount of Authorised Share Capital :	<b>200000000.00</b>		
Class of Shares :	Ordinary	Preference	Others
Amount of Issued Share Capital :	<b>102422757.50</b>	<b>0.00</b>	<b>0.00</b>
Amount of Paid-up Share Capital :	<b>102422757.50</b>	<b>0.00</b>	<b>0.00</b>

GST No. :M9-0008879-T

**RECEIPT**

Receipt No : ACR0000000883270A

Date/Time : 07/10/2004 10:34

Transaction  
No : C040456418

Agency : RCB - RCB

Application : BIZFILE PAYMENT SERVICE

Paid via : Deposit Service Account

EP Ref No :

**SINGAPORE AIRPORT TERMINAL SERVICES LIMITED  
20 AIRPORT BOULEVARD  
SATS INFLIGHT CATERING CENTRE 3  
SINGAPORE 819659**

<b>Sno Code/Description</b>	<b>Unit Price (S\$)</b>	<b>Qty</b>	<b>Amount</b>
1 Lodgment Of Return Of Allotment Of Share <b>COMPANY NAME :</b> 197201770G / SINGAPORE AIRPORT TERMINAL SERVICES LIMITED	10.00	1	10.00
<b>Total (S\$) :</b>			<b>10.00</b>

**Deposit Service Account No. : 030066**  
**Balance Amount in Deposit Account : \$ 475.00**

This is a computer-generated receipt. No signature is required.

Please print a copy of the receipt for your reference.

[HOME](#)[LOGOUT](#)



**Return of Allotment of Shares**

Submit

Please fill in the following information. Fields marked \* must be completed.

Resolution/Declaration	Shares payable in cash	For a consideration other than cash	Share Capital/Allottees Particulars	List of Shareholders after the allotment	Summary of Capital
------------------------	---------------------------	---	---	---	-----------------------

**Record saved successfully.****Company Type**

Please click on appropriate button :

- company is listed on the securities exchange  
 company is an unlisted public company  
 company is a private company

**Power under Section 161 of the Companies Act \***

The directors have obtained the approval of the company in  Yes  No general meeting to issue shares.

**Resolution Made**

\* You are only required to fill in this section if the directors are not given the power under Section 161 of the Companies Act to issue shares.

Registration No. : **197201770G**Company Name : **SINGAPORE AIRPORT TERMINAL SERVICES LIMITED**

Nature of Meeting : \* Directors

Place of Meeting : \*

Date of Meeting : \* (dd/mm/yyyy)

Resolution Type : \* Director's

Description : \*  
(max 2000 characters)Attachment : \*  
(copy of resolution)**Note :**

Uploaded file name will be changed by suffixing time-stamp with the actual file name as

filenameyyyyMMddmmsstt

Browse...

(Click 'Browse' to select file for attachment)

**Persons signing the resolution**

Please indicate the directors/ secretaries who signed the resolution :

- S0036442H / OW CHIN HOCK
- S0070715E / NG KEE CHOE
- S0234645A / CHEW CHOON SENG
- S1001765C / BARRY HENRY PATRICK DESKER
- S1069567H / TAN JIAK NGEE MICHAEL
- S1673157I / YIP WAI PING ANNABELLE
- S1852301I / HONG HAI @ HUANG HAI
- S2163476Z / CHENG WAI WING EDMUND
- S2580327B / RICHARD CHARLES HELFER

Please enter names of other corporate representatives who signed the resolution, if applicable :

**Declaration**

I, LIM HONG ENG SUSANNA, Professional body/service bureau, declare the information which has been submitted herein to be true to the best of my knowledge.

**Return of Allotment of Shares**

Submit

Please fill in the following information. Fields marked \* must be completed.

Resolution / Declaration	Share payable in cash	For a consideration other than cash	Share Capital / Allottees Particulars	List of Shareholders after the allotment	Summary of Capital
-----------------------------	--------------------------	---	---	---	-----------------------

**Particulars of Allottee****Please indicate whether the allottee is an Individual : \***

- Allottee is an Individual  
 Allottee is NOT an Individual

**If Allottee is an Individual :**Shareholder Category : \* **Individual**Identification No. : \*  Retrieve DetailsIdentification Type : \*  ▼Name : \* Nationality : \*  ▼Mobile No : Occupation : Email Address : Address Type : \*  
 Local  
 Foreign

Local Address (\* if Address Type is Local Address)

Postal Code :  Retrieve AddressBlock/House No. :  ▼

Street Name :

Unit : #  - 

Building/Estate Name :

Foreign Address (\* if Address Type is Foreign Address)

Address : **If Allottee is NOT an Individual :**Shareholder Category : \*  ▼ Search

Registration No. : \*

198003912M

Retrieve Details

Name :

THE CENTRAL DEPOSITORY (PTE) LIMITED

Address Type :

Local

Local Address (\* if Address Type is Local Address)

Postal Code : **068804**

Block/House No. : **2**

Street Name : **SHENTON WAY**

Unit : # **19 - 00**

Building/Estate Name : **SGX CENTRE I**

Foreign Address (\* if Address Type is Foreign Address)

Address :

**Details of Shares Allotted** \* Please read instructions carefully before entering.

Note : If any share or shares is/are co-owned by 2 or more persons, please assign an alphabet e.g. A to denote the Group and enter the same in the box. Enter the same alphabet in the box for every allottee in the same group. Skip this box if share(s) are owned by only one person.

Group of Share that is co-owned:  
(Share Group)

If share(s) is/are co-owned, only one allottee is to enter details in (a), (b), (c), (d) and (e). Enter "0" (zero) for subsequent allottees in box (b) and leave blank for rest of the items.

a) Nominal Value per Share :

0.10

b) No. of shares allotted :

92800

c) Class of shares allotted :

Ordinary

d) Currency :

SINGAPORE DOLLAR (099)

e) Date of allotment :

30/09/2004 (dd/mm/yyyy)

Save

Reset

Back

**Return of Allotment of Shares****Submit**

Please fill in the following information. Fields marked \* must be completed.

Resolution / Declaration	Share payable in cash	For a consideration other than cash	Share Capital / Allottees Particulars	List of Shareholders after the Allotment	Summary of Capital
--------------------------	-----------------------	-------------------------------------	---------------------------------------	--	--------------------

**Authorised Capital**

	Amount	Nominal Value per Share	Currency
Authorised Capital :	<b>20000000</b>	<b>.1</b>	<b>SINGAPORE DOLLAR ( 099 )</b>

Description of discrepancy :

**Return of Allotment of Shares (Payable in cash) \***

Applicable only if share is payable in cash

Class of Shares :	Ordinary	Preference	Others
Number of shares :	92800		
Amount paid or due and payable on each share			
paid :	0.10		
due and payable :	0		
Amount of premium paid or payable on each share :	1.50		

**Save****Delete Issued Share****Reset****Back**

**Return of Allotment of Shares****Submit**

Please fill in the following information. Fields marked \* must be completed.

<b>Resolution / Declaration</b>	<b>Share payable in cash</b>	<b>For a consideration other than cash</b>	<b>Share Capital / Allottees Particulars</b>	<b>List of Shareholders after Allotment</b>	<b>Summary of Capital</b>
-------------------------------------	----------------------------------	--	--	---	-------------------------------

**List of Allottees and their particulars****Identification****No./Registration Name****Shareholder Category****No.**

198003912M	THE CENTRAL DEPOSITORY (PTE) LIMITED	Company / Foreign Branch
------------	---	--------------------------

If No. of shareholders exceeds 50, total No. of issued shares held by the remaining shareholders are :

	<b>Ordinary</b>	<b>Preference</b>	<b>Others</b>
<b>No. of Shares</b>	0	0	0

**Return of Allotment of Shares****Submit**

Please fill in the following information. Fields marked \* must be completed.

Resolution / Declaration	Share payable in cash	For a consideration other than cash	Share Capital / Allottees Particulars	List of Shareholders after the allotment	Summary of Capital
--------------------------	-----------------------	-------------------------------------	---------------------------------------	--	--------------------

**Share Capital (1)**

Currency :	<b>SINGAPORE DOLLAR (099)</b>		
Nominal Value per Share :	<b>0.10</b>		
Amount of Authorised Share Capital :	<b>200000000.00</b>		
Class of Shares :	Ordinary	Preference	Others
Amount of Issued Share Capital :	<b>102413137.50</b>	<b>0.00</b>	<b>0.00</b>
Amount of Paid-up Share Capital :	<b>102413137.50</b>	<b>0.00</b>	<b>0.00</b>

✓

**INFORMATION RESOURCES****Receipt Enquiry**

This is a comprehensive listing of receipts available for all transactions.

Receipt No. : ACR0000000883117A  
Date and Time : 07/10/2004 09:45:45  
Payment Mode : DEPOSIT SERVICE ACCOUNT  
Deposit Service Account No : 030066  
Status of Receipt : Processed

**Payment Details**

<b>S/No</b>	<b>Payment Description</b>	<b>Transaction No.</b>	<b>Amount</b>	<b>GST</b>
1	Lodgment Of Return Of Allotment Of Share/Regn No:197201770G/	C040456251	10.00	0.00
<b>Total</b>			<b>10.00</b>	<b>0.00</b>

[Back](#)



**Return of Allotment of Shares****Submit**

Please fill in the following information. Fields marked \* must be completed.

Resolution/Declaration	Shares payable in cash	For a consideration other than cash	Share Capital/Allottees Particulars	List of Shareholders after the allotment	Summary of Capital
------------------------	---------------------------	---	---	---	-----------------------

Record saved successfully.

**Company Type**

Please click on appropriate button :

- company is listed on the securities exchange  
 company is an unlisted public company  
 company is a private company

**Power under Section 161 of the Companies Act \***

The directors have obtained the approval of the company in  Yes  
 general meeting to issue  No shares.

**Resolution Made**

\* You are only required to fill in this section if the directors are not given the power under Section 161 of the Companies Act to issue shares.

Registration No. : **197201770G**Company Name : **SINGAPORE AIRPORT TERMINAL SERVICES LIMITED**Nature of Meeting : \*  

Place of Meeting : \*

Date of Meeting : \*  (dd/mm/yyyy)Resolution Type : \*  Description : \*  
(max 2000 characters)
Attachment : \*  
(copy of resolution)**Note :**

Uploaded file name will be changed by suffixing time-stamp with the actual file name as

filenameyyyyMMddmmsstt

 **Browse...**

(Click 'Browse' to select file for attachment)

### Persons signing the resolution

Please indicate the directors/ secretaries who signed the resolution :

- S0036442H / OW CHIN HOCK
- S0070715E / NG KEE CHOE
- S0234645A / CHEW CHOON SENG
- S1001765C / BARRY HENRY PATRICK DESKER
- S1069567H / TAN JIAK NGEЕ MICHAEL
- S1673157I / YIP WAI PING ANNABELLE
- S1852301I / HONG HAI @ HUANG HAI
- S2163476Z / CHENG WAI WING EDMUND
- S2580327B / RICHARD CHARLES HELFER

Please enter names of other corporate representatives who signed the resolution, if applicable :

### Declaration

I, LIM HONG ENG SUSANNA, Professional body/service bureau, declare the information which has been submitted herein to be true to the best of my knowledge.

**Return of Allotment of Shares**

**Submit**

Please fill in the following information. Fields marked \* must be completed.

Resolution / Declaration	Share payable in cash	For a consideration other than cash	Share Capital / Allottees Particulars	List of Shareholders after the Allotment	Summary of Capital
--------------------------	-----------------------	-------------------------------------	---------------------------------------	--	--------------------

**Authorised Capital**

	Amount	Nominal Value per Share	Currency
Authorised Capital :	<b>200000000</b>	<b>.1</b>	<b>SINGAPORE DOLLAR ( 099 )</b>

Description of discrepancy :

**Return of Allotment of Shares (Payable in cash) \***

Applicable only if share is payable in cash

Class of Shares :	Ordinary	Preference	Others
Number of shares :	<input type="text" value="50000"/>	<input type="text"/>	<input type="text"/>
Amount paid or due and payable on each share			
paid :	<input type="text" value="0.10"/>	<input type="text"/>	<input type="text"/>
due and payable :	<input type="text" value="0"/>	<input type="text"/>	<input type="text"/>
Amount of premium paid or payable on each share :	<input type="text" value="1.14"/>	<input type="text"/>	<input type="text"/>

**Save**    **Delete Issued Share**    **Reset**    **Back**

**Return of Allotment of Shares****Submit**

Please fill in the following information. Fields marked \* must be completed.

Resolution / Declaration	Share payable in cash	For a consideration other than cash	Share Capital / Allottees Particulars	List of Shareholders after the allotment	Summary of Capital
--------------------------	-----------------------	-------------------------------------	---------------------------------------	--	--------------------

**Particulars of Allottee**

Please indicate whether the allottee is an Individual : \*

- Allottee is an Individual  
 Allottee is NOT an Individual

If Allottee is an Individual :

Shareholder Category : \* **Individual**

Identification No. : \*

**Retrieve Details**

Identification Type : \*

Name : \*

Nationality : \*

Mobile No :

Occupation :

Email Address :

Address Type : \*

- Local  
 Foreign

Local Address (\* if Address Type is Local Address)

Postal Code :

**Retrieve Address**

Block/House No. :

Street Name :

Unit : #

 - 

Building/Estate Name :

Foreign Address (\* if Address Type is Foreign Address)

Address :

If Allottee is NOT an Individual :

Shareholder Category : \*

**Search**

Name : **THE CENTRAL DEPOSITORY (PTE) LIMITED**

Address Type : **Local**

Local Address (\* if Address Type is Local Address)

Postal Code : **068804**

Block/House No. : **2**

Street Name : **SHENTON WAY**

Unit : # **19 - 00**

Building/Estate Name : **SGX CENTRE I**

Foreign Address (\* if Address Type is Foreign Address)

Address :

**Details of Shares Allotted** \* Please read instructions carefully before entering.

Note : If any share or shares is/are co-owned by 2 or more persons, please assign an alphabet e.g. A to denote the Group and enter the same in the box. Enter the same alphabet in the box for every allottee in the same group. Skip this box if share(s) are owned by only one person.

Group of Share that is co-owned:  
(Share Group)

If share(s) is/are co-owned, only one allottee is to enter details in (a), (b), (c), (d) and (e). Enter "0" (zero) for subsequent allottees in box (b) and leave blank for rest of the items.

a) Nominal Value per Share :

b) No. of shares allotted :

c) Class of shares allotted :

d) Currency :

e) Date of allotment :  (dd/mm/yyyy)



**LOCAL COMPANY TRANSACTIONS**

HOME

LOGOUT

## Return of Allotment of Shares

Submit

Please fill in the following information. Fields marked \* must be completed.

Resolution / Declaration	Share payable in cash	For a consideration other than cash	Share Capital / Allottees Particulars	List of Shareholders after Allotment	Summary of Capital
-----------------------------	--------------------------	---	---	--	-----------------------

### List of Allottees and their particulars

#### Identification

No./Registration Name  
No.

Shareholder Category

198003912M	THE CENTRAL DEPOSITORY (PTE) LIMITED	Company / Foreign Branch
------------	---	--------------------------

If No. of shareholders exceeds 50, total No. of issued shares held by the remaining shareholders are :

No. of Shares	Ordinary	Preference	Others
	0	0	0

**Return of Allotment of Shares****Submit**

Please fill in the following information. Fields marked \* must be completed.

<b>Resolution / Declaration</b>	<b>Share payable in cash</b>	<b>For a consideration other than cash</b>	<b>Share Capital / Allottees Particulars</b>	<b>List of Shareholders after the allotment</b>	<b>Summary of Capital</b>
<b>Share Capital (1)</b>					
Currency :	<b>SINGAPORE DOLLAR (099)</b>				
Nominal Value per Share :	<b>0.10</b>				
Amount of Authorised Share Capital :	<b>200000000.00</b>				
Class of Shares :	Ordinary	Preference	Others		
Amount of Issued Share Capital :	<b>102403857.50</b>	<b>0.00</b>	<b>0.00</b>		
Amount of Paid-up Share Capital :	<b>102403857.50</b>	<b>0.00</b>	<b>0.00</b>		

**RECEIPT**

Receipt No : ACR0000000883044A

Date/Time : 07/10/2004 09:24

Transaction  
No : C040456184

Agency : RCB - RCB

Application : BIZFILE PAYMENT SERVICE

Paid via : Deposit Service Account

EP Ref No :

**SINGAPORE AIRPORT TERMINAL SERVICES LIMITED**  
**20 AIRPORT BOULEVARD**  
**SATS INFLIGHT CATERING CENTRE 3**  
**SINGAPORE 819659**

<b>Sno Code/Description</b>	<b>Unit Price (S\$)</b>	<b>Qty</b>	<b>Amount</b>
1 Lodgment Of Return Of Allotment Of Share <b>COMPANY NAME :</b> 197201770G / SINGAPORE AIRPORT TERMINAL SERVICES LIMITED	10.00	1	10.00
<b>Total (S\$) :</b>			<b>10.00</b>

**Deposit Service Account No. : 030066**  
**Balance Amount in Deposit Account : \$ 495.00**

This is a computer-generated receipt. No signature is required.

Please print a copy of the receipt for your reference.

[HOME](#)[LOGOUT](#)



**Return of Allotment of Shares****Submit**

Please fill in the following information. Fields marked \* must be completed.

Resolution/Declaration	Shares payable in cash	For a consideration other than cash	Share Capital/Allottees Particulars	List of Shareholders after the allotment	Summary of Capital
------------------------	------------------------	-------------------------------------	-------------------------------------	--	--------------------

**Record saved successfully.****Company Type**

Please click on appropriate button :

- company is listed on the securities exchange ✓
- company is an unlisted public company
- company is a private company

**Power under Section 161 of the Companies Act \***

The directors have obtained the approval of the company in general meeting to issue shares.

Yes ✓

No

**Resolution Made**

\* You are only required to fill in this section if the directors are not given the power under Section 161 of the Companies Act to issue shares.

Registration No. : **197201770G**Company Name : **SINGAPORE AIRPORT TERMINAL SERVICES LIMITED**Nature of Meeting : \* **Directors** ▼Place of Meeting : \*  
  
Date of Meeting : \*  (dd/mm/yyyy)Resolution Type : \* **Director's** ▼Description : \*  
(max 2000 characters)  
Attachment : \*  
(copy of resolution)**Note :**  **Browse...**

Uploaded file name will be changed by suffixing time-stamp with the actual file name as  
**filenameyyyyMMddmmsstt**

(Click 'Browse' to select file for attachment)

Maximum file size: 2010 KB

### Persons signing the resolution

Please indicate the directors/ secretaries who signed the resolution :

- S0036442H / OW CHIN HOCK
- S0070715E / NG KEE CHOE
- S0234645A / CHEW CHOON SENG
- S1001765C / BARRY HENRY PATRICK DESKER
- S1069567H / TAN JIAK NGEE MICHAEL
- S1673157I / YIP WAI PING ANNABELLE
- S1852301I / HONG HAI @ HUANG HAI
- S2163476Z / CHENG WAI WING EDMUND
- S2580327B / RICHARD CHARLES HELFER

Please enter names of other corporate representatives who signed the resolution, if applicable :

### Declaration

I, LIM HONG ENG SUSANNA, Professional body/service bureau, declare the information which has been submitted herein to be true to the best of my knowledge.

**Return of Allotment of Shares**

Please fill in the following information. Fields marked \* must be completed.

Resolution / Declaration	Share payable in cash	For a consideration other than cash	Share Capital / Allottees Particulars	List of Shareholders after the Allotment	Summary of Capital
<b>Authorised Capital</b>					
	Amount		Nominal Value per Share	Currency	
Authorised Capital :	<b>200000000</b>		<b>.1</b>	<b>SINGAPORE DOLLAR ( 099 )</b>	
Description of discrepancy :					

**Return of Allotment of Shares (Payable in cash) \***

Applicable only if share is payable in cash

Class of Shares :	Ordinary	Preference	Others
Number of shares :	<input type="text" value="78600"/>	<input type="text"/>	<input type="text"/>
Amount paid or due and payable on each share			
paid :	<input type="text" value="0.10"/>	<input type="text"/>	<input type="text"/>
due and payable :	<input type="text" value="0"/>	<input type="text"/>	<input type="text"/>
Amount of premium paid or payable on each share :	<input type="text" value="1.70"/>	<input type="text"/>	<input type="text"/>

**Return of Allotment of Shares**

Submit

Please fill in the following information. Fields marked \* must be completed.

Resolution / Declaration	Share payable in cash	For a consideration other than cash	Share Capital / Allottees Particulars	List of Shareholders after the allotment	Summary of Capital
--------------------------	-----------------------	-------------------------------------	---------------------------------------	--	--------------------

**Particulars of Allottee**

Please indicate whether the allottee is an Individual : \*

- Allottee is an Individual  
 Allottee is NOT an Individual

If Allottee is an Individual :

Shareholder Category : \* **Individual**Identification No. : \*  Retrieve DetailsIdentification Type : \* Name : \* Nationality : \* Mobile No : Occupation : Email Address : Address Type : \*  
 Local  
 Foreign

Local Address (\* if Address Type is Local Address)

Postal Code :  Retrieve AddressBlock/House No. : 

Street Name :

Unit : #  - 

Building/Estate Name :

Foreign Address (\* if Address Type is Foreign Address)

Address : 

If Allottee is NOT an Individual :

Shareholder Category : \*  Search

Registration No.: \*

198003912M

Retrieve Details

Name :

**THE CENTRAL DEPOSITORY (PTE) LIMITED**

Address Type :

**Local**

Local Address (\* if Address Type is Local Address)

Postal Code : **068804**

Block/House No. : **2**

Street Name : **SHENTON WAY**

Unit : # **19 - 00**

Building/Estate Name : **SGX CENTRE I**

Foreign Address (\* if Address Type is Foreign Address)

Address :

**Details of Shares Allotted** \* Please read instructions carefully before entering.

Note : If any share or shares is/are co-owned by 2 or more persons, please assign an alphabet e.g. A to denote the Group and enter the same in the box. Enter the same alphabet in the box for every allottee in the same group. Skip this box if share(s) are owned by only one person.

Group of Share that is co-owned:  
(Share Group)

If share(s) is/are co-owned, only one allottee is to enter details in (a), (b), (c), (d) and (e). Enter "0" (zero) for subsequent allottees in box (b) and leave blank for rest of the items.

a) Nominal Value per Share :

0.10

b) No. of shares allotted :

78600

c) Class of shares allotted :

Ordinary

d) Currency :

SINGAPORE DOLLAR (099)

e) Date of allotment :

30/09/2004 (dd/mm/yyyy)

Save

Reset

Back

**Return of Allotment of Shares****Submit**

Please fill in the following information. Fields marked \* must be completed.

<b>Resolution / Declaration</b>	<b>Share payable in cash</b>	<b>For a consideration other than cash</b>	<b>Share Capital / Allottees Particulars</b>	<b>List of Shareholders after Allotment</b>	<b>Summary of Capital</b>
-------------------------------------	----------------------------------	--	--	---	-------------------------------

**List of Allottees and their particulars****Identification****No./Registration Name  
No.****Shareholder Category**

198003912M	THE CENTRAL DEPOSITORY (PTE) LIMITED	Company / Foreign Branch
------------	---	--------------------------

If No. of shareholders exceeds 50, total No. of issued shares held by the remaining shareholders are :

<b>No. of Shares</b>	<b>Ordinary</b>	<b>Preference</b>	<b>Others</b>
	0	0	0

**Return of Allotment of Shares****Submit**

Please fill in the following information. Fields marked \* must be completed.

<b>Resolution / Declaration</b>	<b>Share payable in cash</b>	<b>For a consideration other than cash</b>	<b>Share Capital / Allottees Particulars</b>	<b>List of Shareholders after the allotment</b>	<b>Summary of Capital</b>
<b>Share Capital (1)</b>					
Currency :	<b>SINGAPORE DOLLAR (099)</b>				
Nominal Value per Share :	<b>0.10</b>				
Amount of Authorised Share Capital :	<b>200000000.00</b>				
Class of Shares :	Ordinary	Preference	Others		
Amount of Issued Share Capital :	<b>102398857.50</b>	<b>0.00</b>	<b>0.00</b>		
Amount of Paid-up Share Capital :	<b>102398857.50</b>	<b>0.00</b>	<b>0.00</b>		

GST No. :M9-0008879-T

**RECEIPT**

Receipt No : ACR0000000879373A

Date/Time : 05/10/2004 09:41

Transaction  
No : C040452472

Agency : RCB - RCB

Application : BIZFILE PAYMENT SERVICE

Paid via : Deposit Service Account

EP Ref No :

**SINGAPORE AIRPORT TERMINAL SERVICES LIMITED****20 AIRPORT BOULEVARD****SATS INFLIGHT CATERING CENTRE 3****SINGAPORE 819659**

<b>Sno Code/Description</b>	<b>Unit Price (S\$)</b>	<b>Qty</b>	<b>Amount</b>
1 Lodgment Of Return Of Allotment Of Share <b>COMPANY NAME :</b> 197201770G / SINGAPORE AIRPORT TERMINAL SERVICES LIMITED	10.00	1	10.00
<b>Total (S\$) :</b>			<b>10.00</b>

**Deposit Service Account No. : 030066**  
**Balance Amount in Deposit Account : \$ 505.00**

This is a computer-generated receipt. No signature is required.

Please print a copy of the receipt for your reference.

[HOME](#)[LOGOUT](#)



**Return of Allotment of Shares**

**Submit**

Please fill in the following information. Fields marked \* must be completed.

Resolution/Declaration	Shares payable in cash	For a consideration other than cash	Share Capital/Allottees Particulars	List of Shareholders after the allotment	Summary of Capital
------------------------	------------------------	-------------------------------------	-------------------------------------	--	--------------------

**Record saved successfully.**

**Company Type**

Please click on appropriate button :

- company is listed on the securities exchange
- company is an unlisted public company
- company is a private company

**Power under Section 161 of the Companies Act \***

The directors have obtained the approval of the company in general meeting to issue shares.

Yes    No

**Resolution Made**

\* You are only required to fill in this section if the directors are not given the power under Section 161 of the Companies Act to issue shares.

Registration No. : **197201770G**

Company Name : **SINGAPORE AIRPORT TERMINAL SERVICES LIMITED**

Nature of Meeting : \* **Directors** ▼

Place of Meeting : \*

Date of Meeting: \*  (dd/mm/yyyy)

Resolution Type : \* **Director's** ▼

Description : \*  
(max 2000 characters)

Attachment : \*  
(copy of resolution)

**Note :**

Uploaded file name will be changed by suffixing time-stamp with the actual file name as

**filenameyyyyMMddmmsstt**

**Browse...**

(Click 'Browse' to select file for attachment)

**Persons signing the resolution**

Please indicate the directors/ secretaries who signed the resolution :

- S0036442H / OW CHIN HOCK
- S0070715E / NG KEE CHOE
- S0234645A / CHEW CHOON SENG
- S1001765C / BARRY HENRY PATRICK DESKER
- S1069567H / TAN JIAK NGEER MICHAEL
- S1673157I / YIP WAI PING ANNABELLE
- S1852301I / HONG HAI @ HUANG HAI
- S2163476Z / CHENG WAI WING EDMUND
- S2580327B / RICHARD CHARLES HELFER

Please enter names of other corporate representatives who signed the resolution, if applicable :

**Declaration**

I, LIM HONG ENG SUSANNA, Professional body/service bureau, declare the information which has been submitted herein to be true to the best of my knowledge.

**Return of Allotment of Shares**[Submit](#)

Please fill in the following information. Fields marked \* must be completed.

<u>Resolution / Declaration</u>	<u>Share payable in cash</u>	<u>For a consideration other than cash</u>	<u>Share Capital / Allottees Particulars</u>	<u>List of Shareholders after the Allotment</u>	<u>Summary of Capital</u>
---------------------------------	------------------------------	--	--	---	---------------------------

**Authorised Capital**

	<u>Amount</u>	<u>Nominal Value per Share</u>	<u>Currency</u>
Authorised Capital :	<b>20000000</b>	<b>.1</b>	<b>SINGAPORE DOLLAR ( 099 )</b>

Description of discrepancy :

**Return of Allotment of Shares (Payable in cash) \***

Applicable only if share is payable in cash

<u>Class of Shares :</u>	<u>Ordinary</u>	<u>Preference</u>	<u>Others</u>
Number of shares :	<input type="text" value="98800"/>	<input type="text"/>	<input type="text"/>
Amount paid or due and payable on each share			
paid :	<input type="text" value="0.10"/>	<input type="text"/>	<input type="text"/>
due and payable :	<input type="text" value="0"/>	<input type="text"/>	<input type="text"/>
Amount of premium paid or payable on each share :	<input type="text" value="1.50"/>	<input type="text"/>	<input type="text"/>

[Save](#)
[Delete Issued Share](#)
[Reset](#)
[Back](#)

**Return of Allotment of Shares**

Submit

Please fill in the following information. Fields marked \* must be completed.

Resolution / Declaration	Share payable in cash	For a consideration other than cash	Share Capital / Allottees Particulars	List of Shareholders after the allotment	Summary of Capital
--------------------------	-----------------------	-------------------------------------	---------------------------------------	--	--------------------

**Particulars of Allottee**

Please indicate whether the allottee is an Individual : \*

- Allottee is an Individual  
 Allottee is NOT an Individual

If Allottee is an Individual :

Shareholder Category : \* **Individual**Identification No. : \*  Retrieve DetailsIdentification Type : \* Name : \* Nationality : \* Mobile No : Occupation : Email Address : 

Address Type : \*  
 Local  
 Foreign

Local Address (\* if Address Type is Local Address)

Postal Code :  Retrieve AddressBlock/House No. : Street Name : Unit : #  - Building/Estate Name : 

Foreign Address (\* if Address Type is Foreign Address)

Address : 

If Allottee is NOT an Individual :

Shareholder Category : \*  Search

Registration No. : **19800512M THE CENTRAL DEPOSITORY (PTE) LIMITED**

Name : **THE CENTRAL DEPOSITORY (PTE) LIMITED**  
Address Type : **Local**

Local Address (\* if Address Type is Local Address)

Postal Code : **068804**

Block/House No. : **2**

Street Name : **SHENTON WAY**

Unit : # **19 - 00**

Building/Estate Name : **SGX CENTRE I**

Foreign Address (\* if Address Type is Foreign Address)

Address :

**Details of Shares Allotted** \* Please read instructions carefully before entering.

Note : If any share or shares is/are co-owned by 2 or more persons, please assign an alphabet e.g. A to denote the Group and enter the same in the box. Enter the same alphabet in the box for every allottee in the same group. Skip this box if share(s) are owned by only one person.

Group of Share that is co-owned:   
(Share Group)

If share(s) is/are co-owned, only one allottee is to enter details in (a), (b), (c), (d) and (e). Enter "0" (zero) for subsequent allottees in box (b) and leave blank for rest of the items.

- a) Nominal Value per Share :  ✓
- b) No. of shares allotted :  ✓
- c) Class of shares allotted :  ✓
- d) Currency :  ✓
- e) Date of allotment :  (dd/mm/yyyy) ✓

**Return of Allotment of Shares****Submit**

Please fill in the following information. Fields marked \* must be completed.

<b>Resolution / Declaration</b>	<b>Share payable in cash</b>	<b>For a consideration other than cash</b>	<b>Share Capital / Allottees Particulars</b>	<b>List of Shareholders after Allotment</b>	<b>Summary of Capital</b>
-------------------------------------	----------------------------------	--	--	---	-------------------------------

**List of Allottees and their particulars****Identification****No./Registration Name  
No.****Shareholder Category**

198003912M	THE CENTRAL DEPOSITORY (PTE) LIMITED	Company / Foreign Branch
------------	---	--------------------------

If No. of shareholders exceeds 50, total No. of issued shares held by the remaining shareholders are :

<b>No. of Shares</b>	<b>Ordinary</b>	<b>Preference</b>	<b>Others</b>
	0	0	0

**Return of Allotment of Shares**

Submit

Please fill in the following information. Fields marked \* must be completed.

Resolution / Declaration	Share payable in cash	For a consideration other than cash	Share Capital / Allottees Particulars	List of Shareholders after the allotment	Summary of Capital
<b>Share Capital (1)</b>					
Currency :	<b>SINGAPORE DOLLAR (099)</b>				
Nominal Value per Share :	<b>0.10</b>				
Amount of Authorised Share Capital :	<b>200000000.00</b>				
Class of Shares :	Ordinary	Preference	Others		
Amount of Issued Share Capital :	<b>102390997.50</b>	<b>0.00</b>	<b>0.00</b>		
Amount of Paid-up Share Capital :	<b>102390997.50</b>	<b>0.00</b>	<b>0.00</b>		

**INFORMATION RESOURCES****Receipt Enquiry**

This is a comprehensive listing of receipts available for all transactions.

Receipt No. : ACR0000000879294A  
Date and Time : 05/10/2004 09:16:52  
Payment Mode : DEPOSIT SERVICE ACCOUNT  
Deposit Service Account No : 030066  
Status of Receipt : Processed

**Payment Details**

<b>S/No</b>	<b>Payment Description</b>	<b>Transaction No.</b>	<b>Amount</b>	<b>GST</b>
1	Lodgment Of Return Of Allotment Of Share/Regn No:197201770G/	C040452409	10.00	0.00
<b>Total</b>			<b>10.00</b>	<b>0.00</b>

[Back](#)



**LOCAL COMPANY TRANSACTIONS**[HOME](#) [LOGOUT](#)**Return of Allotment of Shares**[Submit](#)

Please fill in the following information. Fields marked \* must be completed.

Resolution/Declaration	Shares payable in cash	For a consideration other than cash	Share Capital/Allottees Particulars	List of Shareholders after the allotment	Summary of Capital
------------------------	------------------------	-------------------------------------	-------------------------------------	--	--------------------

**Record saved successfully.****Company Type**

Please click on appropriate button :

- company is listed on the securities exchange
- company is an unlisted public company
- company is a private company

**Power under Section 161 of the Companies Act \***

The directors have obtained the approval of the company in  Yes  No general meeting to issue shares.

**Resolution Made**

\* You are only required to fill in this section if the directors are not given the power under Section 161 of the Companies Act to issue shares.

Registration No. : **197201770G**Company Name : **SINGAPORE AIRPORT TERMINAL SERVICES LIMITED**Nature of Meeting : \* Place of Meeting : \* Date of Meeting : \*  (dd/mm/yyyy)Resolution Type : \* Description : \* (max 2000 characters) 

Attachment : \* (copy of resolution)

**Note :**  [Browse...](#)

Uploaded file name will be changed by suffixing time-stamp with the actual file name as **filenameyyyyMMddmmsstt**

(Click 'Browse' to select file for attachment)

### Persons signing the resolution

Please indicate the directors/ secretaries who signed the resolution :

- S0036442H / OW CHIN HOCK
- S0070715E / NG KEE CHOE
- S0234645A / CHEW CHOON SENG
- S1001765C / BARRY HENRY PATRICK DESKER
- S1069567H / TAN JIAK NGEER MICHAEL
- S1673157I / YIP WAI PING ANNABELLE
- S1852301I / HONG HAI @ HUANG HAI
- S2163476Z / CHENG WAI WING EDMUND
- S2580327B / RICHARD CHARLES HELFER

Please enter names of other corporate representatives who signed the resolution, if applicable :

### Declaration

I, LIM HONG ENG SUSANNA, Professional body/service bureau, declare the information which has been submitted herein to be true to the best of my knowledge.

**Return of Allotment of Shares**

[Submit](#)

Please fill in the following information. Fields marked \* must be completed.

Resolution / Declaration	Share payable in cash	For a consideration other than cash	Share Capital / Allottees Particulars	List of Shareholders after the Allotment	Summary of Capital
--------------------------	-----------------------	-------------------------------------	---------------------------------------	--	--------------------

**Authorised Capital**

	Amount	Nominal Value per Share	Currency
Authorised Capital :	<b>200000000</b>	<b>.1</b>	<b>SINGAPORE DOLLAR ( 099 )</b>

Description of discrepancy :

**Return of Allotment of Shares (Payable in cash) \***

Applicable only if share is payable in cash

Class of Shares :	Ordinary	Preference	Others
Number of shares :	<input type="text" value="15600"/>	<input type="text"/>	<input type="text"/>
Amount paid or due and payable on each share			
paid :	<input type="text" value="0.10"/>	<input type="text"/>	<input type="text"/>
due and payable :	<input type="text" value="0"/>	<input type="text"/>	<input type="text"/>
Amount of premium paid or payable on each share :	<input type="text" value="1.14"/>	<input type="text"/>	<input type="text"/>

[Save](#)   
 [Delete Issued Share](#)   
 [Reset](#)   
 [Back](#)

**Return of Allotment of Shares****Submit**

Please fill in the following information. Fields marked \* must be completed.

Resolution / Declaration	Share payable in cash	For a consideration other than cash	Share Capital / Allottees Particulars	List of Shareholders after the allotment	Summary of Capital
--------------------------	-----------------------	-------------------------------------	---------------------------------------	--	--------------------

**Particulars of Allottee**

Please indicate whether the allottee is an Individual : \*

- Allottee is an Individual  
 Allottee is NOT an Individual

If Allottee is an Individual :

Shareholder Category : \* **Individual**Identification No. : \*  **Retrieve Details**Identification Type : \* Name : \* Nationality : \* Mobile No : Occupation : Email Address : Address Type : \*  Local  
 Foreign

Local Address (\* if Address Type is Local Address)

Postal Code :  **Retrieve Address**Block/House No. : Street Name : Unit : #  - Building/Estate Name : 

Foreign Address (\* if Address Type is Foreign Address)

Address : 

If Allottee is NOT an Individual :

Shareholder Category : \*  **Search**

Registration No. : \*

198003912M

Retrieve Details

Name :

**THE CENTRAL DEPOSITORY (PTE) LIMITED**

Address Type :

**Local**

Local Address (\* if Address Type is Local Address)

Postal Code : **068804**

Block/House No. : **2**

Street Name : **SHENTON WAY**

Unit : # **19 - 00**

Building/Estate Name : **SGX CENTRE I**

Foreign Address (\* if Address Type is Foreign Address)

Address :

**Details of Shares Allotted** \* Please read instructions carefully before entering.

Note : If any share or shares is/are co-owned by 2 or more persons, please assign an alphabet e.g. A to denote the Group and enter the same in the box. Enter the same alphabet in the box for every allottee in the same group. Skip this box if share(s) are owned by only one person.

Group of Share that is co-owned:  
(Share Group)

If share(s) is/are co-owned, only one allottee is to enter details in (a), (b), (c), (d) and (e). Enter "0" (zero) for subsequent allottees in box (b) and leave blank for rest of the items.

a) Nominal Value per Share :

0.10

b) No. of shares allotted :

15600

c) Class of shares allotted :

Ordinary

d) Currency :

SINGAPORE DOLLAR (099)

e) Date of allotment :

29/09/2004 (dd/mm/yyyy)

Save

Reset

Back

**Return of Allotment of Shares**

Please fill in the following information. Fields marked \* must be completed.

Resolution / Declaration	Share payable in cash	For a consideration other than cash	Share Capital / Allottees Particulars	List of Shareholders after Allotment	Summary of Capital
-----------------------------	--------------------------	---	---	--	-----------------------

**List of Allottees and their particulars****Identification****No./Registration Name  
No.****Shareholder Category**

198003912M	THE CENTRAL DEPOSITORY (PTE) LIMITED	Company / Foreign Branch
------------	---	--------------------------

If No. of shareholders exceeds 50, total No. of issued shares held by the remaining shareholders are :

No. of Shares	Ordinary	Preference	Others
	0	0	0

**LOCAL COMPANY TRANSACTIONS**

HOME	LOGOUT
------	--------

**Return of Allotment of Shares****Submit**

Please fill in the following information. Fields marked \* must be completed.

Resolution / Declaration	Share payable in cash	For a consideration other than cash	Share Capital / Allottees Particulars	List of Shareholders after the allotment	Summary of Capital
--------------------------	-----------------------	-------------------------------------	---------------------------------------	--	--------------------

**Share Capital (1)**

Currency :	<b>SINGAPORE DOLLAR (099)</b>		
Nominal Value per Share :	<b>0.10</b>		
Amount of Authorised Share Capital :	<b>200000000.00</b>		
Class of Shares :	Ordinary	Preference	Others
Amount of Issued Share Capital :	<b>102381117.50</b>	<b>0.00</b>	<b>0.00</b>
Amount of Paid-up Share Capital :	<b>102381117.50</b>	<b>0.00</b>	<b>0.00</b>

GST No. :M9-0008879-T

**RECEIPT**

Receipt No : ACR0000000879285A

Date/Time : 05/10/2004 09:07

Transaction  
No : C040452397

Agency : RCB - RCB

Application : BIZFILE PAYMENT SERVICE

Paid via : Deposit Service Account

EP Ref No :

**SINGAPORE AIRPORT TERMINAL SERVICES LIMITED****20 AIRPORT BOULEVARD****SATS INFLIGHT CATERING CENTRE 3****SINGAPORE 819659**

<b>Sno Code/Description</b>	<b>Unit Price (S\$)</b>	<b>Qty</b>	<b>Amount</b>
1 Lodgment Of Return Of Allotment Of Share <b>COMPANY NAME :</b> 197201770G / SINGAPORE AIRPORT TERMINAL SERVICES LIMITED	10.00	1	10.00
<b>Total (S\$) :</b>			<b>10.00</b>

**Deposit Service Account No. : 030066****Balance Amount in Deposit Account : \$ 525.00**

This is a computer-generated receipt. No signature is required.

Please print a copy of the receipt for your reference.

[HOME](#)[LOGOUT](#)



**Return of Allotment of Shares****Submit**

Please fill in the following information. Fields marked \* must be completed.

Resolution/Declaration	Shares payable in cash	For a consideration other than cash	Share Capital/Allottees Particulars	List of Shareholders after the allotment	Summary of Capital
------------------------	---------------------------	---	---	---	-----------------------

**Record saved successfully.****Company Type**

Please click on appropriate button :

- company is listed on the securities exchange  
 company is an unlisted public company  
 company is a private company

**Power under Section 161 of the Companies Act \***

The directors have obtained  
the approval of the company in  Yes  
general meeting to issue  No  
shares.

**Resolution Made**

\* You are only required to fill in this section if the directors are not given the power under Section 161 of the Companies Act to issue shares.

Registration No. : **197201770G**Company Name : **SINGAPORE AIRPORT TERMINAL SERVICES LIMITED**Nature of Meeting : \* **Directors** ▼

Place of Meeting : \*

Date of Meeting : \*  (dd/mm/yyyy)Resolution Type : \* **Director's** ▼Description : \*  
(max 2000 characters)Attachment : \*  
(copy of resolution)**Note :**

Uploaded file name will be  
changed by suffixing time-  
stamp with the actual file  
name as

**filenameyyyyMMddmmsstt****Browse...**

(Click 'Browse' to select file for attachment)

**Persons signing the resolution**

Please indicate the directors/ secretaries who signed the resolution :

- S0036442H / OW CHIN HOCK
- S0070715E / NG KEE CHOE
- S0234645A / CHEW CHOON SENG
- S1001765C / BARRY HENRY PATRICK DESKER
- S1069567H / TAN JIAK NGEE MICHAEL
- S1673157I / YIP WAI PING ANNABELLE
- S1852301I / HONG HAI @ HUANG HAI
- S2163476Z / CHENG WAI WING EDMUND
- S2580327B / RICHARD CHARLES HELFER

Please enter names of other corporate representatives who signed the resolution, if applicable :

**Declaration**

I, LIM HONG ENG SUSANNA, Professional body/service bureau, declare the information which has been submitted herein to be true to the best of my knowledge.

**Return of Allotment of Shares**[Submit](#)

Please fill in the following information. Fields marked \* must be completed.

Resolution / Declaration	Share payable in cash	For a consideration other than cash	Share Capital / Allottees Particulars	List of Shareholders after the Allotment	Summary of Capital
--------------------------	-----------------------	-------------------------------------	---------------------------------------	--	--------------------

**Authorised Capital**

	Amount	Nominal Value per Share	Currency
Authorised Capital :	<b>20000000</b>	<b>.1</b>	<b>SINGAPORE DOLLAR ( 099 )</b>

Description of discrepancy :

**Return of Allotment of Shares (Payable in cash) \***

Applicable only if share is payable in cash

Class of Shares :	Ordinary	Preference	Others
Number of shares :	<input type="text" value="28600"/>	<input type="text"/>	<input type="text"/>
Amount paid or due and payable on each share			
paid :	<input type="text" value="0.10"/>	<input type="text"/>	<input type="text"/>
due and payable :	<input type="text" value="0"/>	<input type="text"/>	<input type="text"/>
Amount of premium paid or payable on each share :	<input type="text" value="1.70"/>	<input type="text"/>	<input type="text"/>

[Save](#)
[Delete Issued Share](#)
[Reset](#)
[Back](#)

**Return of Allotment of Shares**

Submit

Please fill in the following information. Fields marked \* must be completed.

Resolution / Declaration	Share payable in cash	For a consideration other than cash	Share Capital / Allottees Particulars	List of Shareholders after the allotment	Summary of Capital
-----------------------------	--------------------------	---	---	---	-----------------------

**Particulars of Allottee**

Please indicate whether the allottee is an Individual : \*

- Allottee is an Individual  
 Allottee is NOT an Individual

If Allottee is an Individual :

Shareholder Category : \* **Individual**Identification No. : \*  Retrieve DetailsIdentification Type : \* Name : \* Nationality : \* Mobile No : Occupation : Email Address : Address Type : \*  
 Local  
 Foreign

Local Address (\* if Address Type is Local Address)

Postal Code :  Retrieve AddressBlock/House No. : Street Name : Unit : #  - Building/Estate Name : 

Foreign Address (\* if Address Type is Foreign Address)

Address : 

If Allottee is NOT an Individual :

Shareholder Category : \*  Search

Registration No. : \*

198003912M

Retrieve Details

Name :

**THE CENTRAL DEPOSITORY (PTE) LIMITED**

Address Type :

**Local**

Local Address (\* if Address Type is Local Address)

Postal Code : **068804**

Block/House No. : **2**

Street Name : **SHENTON WAY**

Unit : # **19 - 00**

Building/Estate Name : **SGX CENTRE I**

Foreign Address (\* if Address Type is Foreign Address)

Address :

**Details of Shares Allotted** \* Please read instructions carefully before entering.

Note : If any share or shares is/are co-owned by 2 or more persons, please assign an alphabet e.g. A to denote the Group and enter the same in the box. Enter the same alphabet in the box for every allottee in the same group. Skip this box if share(s) are owned by only one person.

Group of Share that is co-owned:  
(Share Group)

If share(s) is/are co-owned, only one allottee is to enter details in (a), (b), (c), (d) and (e). Enter "0" (zero) for subsequent allottees in box (b) and leave blank for rest of the items.

a) Nominal Value per Share :

0.10

b) No. of shares allotted :

28600

c) Class of shares allotted :

Ordinary

d) Currency :

SINGAPORE DOLLAR (099)

e) Date of allotment :

29/09/2004

(dd/mm/yyyy)

Save

Reset

Back

**Return of Allotment of Shares****Submit**

Please fill in the following information. Fields marked \* must be completed.

<b>Resolution / Declaration</b>	<b>Share payable in cash</b>	<b>For a consideration other than cash</b>	<b>Share Capital / Allottees Particulars</b>	<b>List of Shareholders after Allotment</b>	<b>Summary of Capital</b>
-------------------------------------	----------------------------------	--	--	---	-------------------------------

**List of Allottees and their particulars****Identification****No./Registration Name  
No.****Shareholder Category**

198003912M	THE CENTRAL DEPOSITORY (PTE) LIMITED	Company / Foreign Branch
------------	---	--------------------------

If No. of shareholders exceeds 50, total No. of issued shares held by the remaining shareholders are :

<b>No. of Shares</b>	<b>Ordinary</b>	<b>Preference</b>	<b>Others</b>
	0	0	0

**Return of Allotment of Shares**

Submit

Please fill in the following information. Fields marked \* must be completed.

Resolution / Declaration	Share payable in cash	For a consideration other than cash	Share Capital / Allottees Particulars	List of Shareholders after the allotment	Summary of Capital
--------------------------	-----------------------	-------------------------------------	---------------------------------------	--	--------------------

**Share Capital (1)**

Currency :	<b>SINGAPORE DOLLAR (099)</b>				
Nominal Value per Share :	<b>0.10</b>				
Amount of Authorised Share Capital :	<b>200000000.00</b>				
Class of Shares :	Ordinary	Preference	Others		
Amount of Issued Share Capital :	<b>102379557.50</b>	<b>0.00</b>	<b>0.00</b>		
Amount of Paid-up Share Capital :	<b>102379557.50</b>	<b>0.00</b>	<b>0.00</b>		

**RECEIPT**

Receipt No : ACR0000000877737A

Date/Time : 04/10/2004 10:57

Transaction No : C040450781

Agency : RCB - RCB

Application : BIZFILE PAYMENT SERVICE

Paid via : Deposit Service Account

EP Ref No :

**SINGAPORE AIRPORT TERMINAL SERVICES LIMITED**  
**20 AIRPORT BOULEVARD**  
**SATS INFLIGHT CATERING CENTRE 3**  
**SINGAPORE 819659**

<b>Sno Code/Description</b>	<b>Unit Price (S\$)</b>	<b>Qty</b>	<b>Amount</b>
1 Lodgment Of Return Of Allotment Of Share <b>COMPANY NAME :</b> 197201770G / SINGAPORE AIRPORT TERMINAL SERVICES LIMITED	10.00	1	10.00
<b>Total (S\$) :</b>			<b>10.00</b>

**Deposit Service Account No. : 030066**  
**Balance Amount in Deposit Account : \$ 545.00**

This is a computer-generated receipt. No signature is required.

Please print a copy of the receipt for your reference.

[HOME](#)[LOGOUT](#)



**Return of Allotment of Shares****Submit**

Please fill in the following information. Fields marked \* must be completed.

Resolution/Declaration	Shares payable in cash	For a consideration other than cash	Share Capital/Allottees Particulars	List of Shareholders after the allotment	Summary of Capital
------------------------	---------------------------	---	---	---	-----------------------

**Record saved successfully.****Company Type**

Please click on appropriate button :

- company is listed on the securities exchange
- company is an unlisted public company
- company is a private company

**Power under Section 161 of the Companies Act \***

The directors have obtained the approval of the company in general meeting to issue shares.

Yes       No

**Resolution Made**

\* You are only required to fill in this section if the directors are not given the power under Section 161 of the Companies Act to issue shares.

Registration No. : **197201770G**Company Name : **SINGAPORE AIRPORT TERMINAL SERVICES LIMITED**Nature of Meeting : \* **Directors**Place of Meeting : \*  
  
Date of Meeting : \*  (dd/mm/yyyy)Resolution Type : \* **Director's**Description : \*  
(max 2000 characters)  
Attachment : \*  
(copy of resolution)Note :  **Browse...**

Uploaded file name will be changed by suffixing time-stamp with the actual file name as

**filenameyyyyMMddmmsstt**

(Click 'Browse' to select file for attachment)

### Persons signing the resolution

Please indicate the directors/ secretaries who signed the resolution :

- S0036442H / OW CHIN HOCK
- S0070715E / NG KEE CHOE
- S0234645A / CHEW CHOON SENG
- S1001765C / BARRY HENRY PATRICK DESKER
- S1069567H / TAN JIAK NGEE MICHAEL
- S1673157I / YIP WAI PING ANNABELLE
- S1852301I / HONG HAI @ HUANG HAI
- S2163476Z / CHENG WAI WING EDMUND
- S2580327B / RICHARD CHARLES HELFER

Please enter names of other corporate representatives who signed the resolution, if applicable :

### Declaration

I, LIM HONG ENG SUSANNA, Professional body/service bureau, declare the information which has been submitted herein to be true to the best of my knowledge.

**LOCAL COMPANY TRANSACTIONS**[HOME](#) [LOGOUT](#)**Return of Allotment of Shares**[Submit](#)

Please fill in the following information. Fields marked \* must be completed.

Resolution / Declaration	Share payable in cash	For a consideration other than cash	Share Capital / Allottees Particulars	List of Shareholders after the Allotment	Summary of Capital
--------------------------	-----------------------	-------------------------------------	---------------------------------------	--	--------------------

**Authorised Capital**

	Amount	Nominal Value per Share	Currency
Authorised Capital :	<b>20000000</b>	<b>.1</b>	<b>SINGAPORE DOLLAR ( 099 )</b>

Description of discrepancy :

**Return of Allotment of Shares (Payable in cash) \***

Applicable only if share is payable in cash

Class of Shares :	Ordinary	Preference	Others
Number of shares :	<input type="text" value="94200"/>	<input type="text"/>	<input type="text"/>
Amount paid or due and payable on each share			
paid :	<input type="text" value="0.10"/>	<input type="text"/>	<input type="text"/>
due and payable :	<input type="text" value="0"/>	<input type="text"/>	<input type="text"/>
Amount of premium paid or payable on each share :	<input type="text" value="1.50"/>	<input type="text"/>	<input type="text"/>

[Save](#)
[Delete Issued Share](#)
[Reset](#)
[Back](#)

**Return of Allotment of Shares**

Submit

Please fill in the following information. Fields marked \* must be completed.

Resolution / Declaration	Share payable in cash	For a consideration other than cash	Share Capital / Allottees Particulars	List of Shareholders after the allotment	Summary of Capital
-----------------------------	--------------------------	---	---	---	-----------------------

**Particulars of Allottee**

Please indicate whether the allottee is an Individual : \*

- Allottee is an Individual  
 Allottee is NOT an Individual

If Allottee is an Individual :

Shareholder Category : \* **Individual**Identification No. : \*  Retrieve DetailsIdentification Type : \* Name : \* Nationality : \* Mobile No : Occupation : Email Address : Address Type : \*  
 Local  
 Foreign

Local Address (\* if Address Type is Local Address)

Postal Code :  Retrieve AddressBlock/House No. : Street Name : Unit : #  - Building/Estate Name : 

Foreign Address (\* if Address Type is Foreign Address)

Address : 

If Allottee is NOT an Individual :

Shareholder Category : \*  Search

Registration No.: \*

198003912M

Retrieve Details

Name :

**THE CENTRAL DEPOSITORY (PTE) LIMITED**

Address Type :

**Local**

Local Address (\* if Address Type is Local Address)

Postal Code : **068804**

Block/House No. : **2**

Street Name : **SHENTON WAY**

Unit : # **19 - 00**

Building/Estate Name : **SGX CENTRE I**

Foreign Address (\* if Address Type is Foreign Address)

Address :

**Details of Shares Allotted** \* Please read instructions carefully before entering.

Note : If any share or shares is/are co-owned by 2 or more persons, please assign an alphabet e.g. A to denote the Group and enter the same in the box. Enter the same alphabet in the box for every allottee in the same group. Skip this box if share(s) are owned by only one person.

Group of Share that is co-owned:  
(Share Group)

If share(s) is/are co-owned, only one allottee is to enter details in (a), (b), (c), (d) and (e). Enter "0" (zero) for subsequent allottees in box (b) and leave blank for rest of the items.

a) Nominal Value per Share :

0.10

b) No. of shares allotted :

94200

c) Class of shares allotted :

Ordinary

d) Currency :

SINGAPORE DOLLAR (099)

e) Date of allotment :

28/09/2004 (dd/mm/yyyy)

Save

Reset

Back

**Return of Allotment of Shares****Submit**

Please fill in the following information. Fields marked \* must be completed.

<b>Resolution / Declaration</b>	<b>Share payable in cash</b>	<b>For a consideration other than cash</b>	<b>Share Capital / Allottees Particulars</b>	<b>List of Shareholders after Allotment</b>	<b>Summary of Capital</b>
-------------------------------------	----------------------------------	--	--	---	-------------------------------

**List of Allottees and their particulars****Identification****No./Registration Name  
No.****Shareholder Category**

198003912M	THE CENTRAL DEPOSITORY (PTE) LIMITED	Company / Foreign Branch
------------	---	--------------------------

If No. of shareholders exceeds 50, total No. of issued shares held by the remaining shareholders are :

<b>No. of Shares</b>	<b>Ordinary</b>	<b>Preference</b>	<b>Others</b>
	0	0	0

**Return of Allotment of Shares**

Submit

Please fill in the following information. Fields marked \* must be completed.

Resolution / Declaration	Share payable in cash	For a consideration other than cash	Share Capital / Allottees Particulars	List of Shareholders after the allotment	Summary of Capital
<b>Share Capital (1)</b>					
Currency :	<b>SINGAPORE DOLLAR (099)</b>				
Nominal Value per Share :	<b>0.10</b>				
Amount of Authorised Share Capital :	<b>200000000.00</b>				
Class of Shares :	Ordinary	Preference	Others		
Amount of Issued Share Capital :	<b>102376697.50</b>	<b>0.00</b>	<b>0.00</b>		
Amount of Paid-up Share Capital :	<b>102376697.50</b>	<b>0.00</b>	<b>0.00</b>		

**RECEIPT**

Receipt No : ACR0000000877565A

Date/Time : 04/10/2004 10:13

Transaction No : C040450591

Agency : RCB - RCB

Application : BIZFILE PAYMENT SERVICE

Paid via : Deposit Service Account

EP Ref No :

**SINGAPORE AIRPORT TERMINAL SERVICES LIMITED****20 AIRPORT BOULEVARD****SATS INFLIGHT CATERING CENTRE 3****SINGAPORE 819659**

---

<b>Sno Code/Description</b>	<b>Unit Price (S\$)</b>	<b>Qty</b>	<b>Amount</b>
1 Lodgment Of Return Of Allotment Of Share <b>COMPANY NAME :</b> 197201770G / SINGAPORE AIRPORT TERMINAL SERVICES LIMITED	10.00	1	10.00
<b>Total (S\$) :</b>			<b>10.00</b>

---

**Deposit Service Account No. : 030066**  
**Balance Amount in Deposit Account : \$ 555.00**

This is a computer-generated receipt. No signature is required.

Please print a copy of the receipt for your reference.

[HOME](#)[LOGOUT](#)



**Return of Allotment of Shares**

Submit

Please fill in the following information. Fields marked \* must be completed.

Resolution/Declaration	Shares payable in cash	For a consideration other than cash	Share Capital/Allottees Particulars	List of Shareholders after the allotment	Summary of Capital
------------------------	---------------------------	---	---	---	-----------------------

**Record saved successfully.****Company Type**

Please click on appropriate button :

- company is listed on the securities exchange  
 company is an unlisted public company  
 company is a private company

**Power under Section 161 of the Companies Act \***

The directors have obtained the approval of the company in  Yes  No general meeting to issue shares.

**Resolution Made**

\* You are only required to fill in this section if the directors are not given the power under Section 161 of the Companies Act to issue shares.

Registration No. : **197201770G**Company Name : **SINGAPORE AIRPORT TERMINAL SERVICES LIMITED**

Nature of Meeting : \* Directors

Place of Meeting : \*

Date of Meeting : \* (dd/mm/yyyy)

Resolution Type : \* Director's

Description : \*  
(max 2000 characters)Attachment : \*  
(copy of resolution)**Note :**

Uploaded file name will be changed by suffixing time-stamp with the actual file name as

**filenameyyyyMMddmmsstt**

Browse...

(Click 'Browse' to select file for attachment)

**Persons signing the resolution**

Please indicate the directors/ secretaries who signed the resolution :

- S0036442H / OW CHIN HOCK
- S0070715E / NG KEE CHOE
- S0234645A / CHEW CHOON SENG
- S1001765C / BARRY HENRY PATRICK DESKER
- S1069567H / TAN JIAK NGEE MICHAEL
- S1673157I / YIP WAI PING ANNABELLE
- S1852301I / HONG HAI @ HUANG HAI
- S2163476Z / CHENG WAI WING EDMUND
- S2580327B / RICHARD CHARLES HELFER

Please enter names of other corporate representatives who signed the resolution, if applicable :

**Declaration**

I, LIM HONG ENG SUSANNA, Professional body/service bureau, declare the information which has been submitted herein to be true to the best of my knowledge.

**Return of Allotment of Shares**

[Submit](#)

Please fill in the following information. Fields marked \* must be completed.

Resolution / Declaration	Share payable in cash	For a consideration other than cash	Share Capital / Allottees Particulars	List of Shareholders after the Allotment	Summary of Capital
--------------------------	-----------------------	-------------------------------------	---------------------------------------	--	--------------------

**Authorised Capital**

	Amount	Nominal Value per Share	Currency
Authorised Capital :	<b>200000000</b>	<b>.1</b>	<b>SINGAPORE DOLLAR ( 099 )</b>

Description of discrepancy :

**Return of Allotment of Shares (Payable in cash) \***

Applicable only if share is payable in cash

Class of Shares :	Ordinary	Preference	Others
Number of shares :	<input type="text" value="10400"/>	<input type="text"/>	<input type="text"/>
Amount paid or due and payable on each share			
paid :	<input type="text" value="0.10"/>	<input type="text"/>	<input type="text"/>
due and payable :	<input type="text" value="0"/>	<input type="text"/>	<input type="text"/>
Amount of premium paid or payable on each share :	<input type="text" value="1.14"/>	<input type="text"/>	<input type="text"/>

[Save](#)   [Delete Issued Share](#)   [Reset](#)   [Back](#)

**Return of Allotment of Shares**

Submit

Please fill in the following information. Fields marked \* must be completed.

Resolution / Declaration	Share payable in cash	For a consideration other than cash	Share Capital / Allottees Particulars	List of Shareholders after the allotment	Summary of Capital
--------------------------	-----------------------	-------------------------------------	---------------------------------------	--	--------------------

**Particulars of Allottee****Please indicate whether the allottee is an Individual : \***

- Allottee is an Individual  
 Allottee is NOT an Individual

**If Allottee is an Individual :**Shareholder Category : \* **Individual**Identification No. : \*  Retrieve DetailsIdentification Type : \*  ▼Name : \* Nationality : \*  ▼Mobile No. : Occupation : Email Address : 
 Address Type : \*  
 Local  
 Foreign

Local Address (\* if Address Type is Local Address)

Postal Code :  Retrieve AddressBlock/House No. : Street Name : Unit : #  - Building/Estate Name : 

Foreign Address (\* if Address Type is Foreign Address)

Address : **If Allottee is NOT an Individual :**Shareholder Category : \*  Search

Registration No. : \*

198003912M

Retrieve Details

Name :

THE CENTRAL DEPOSITORY (PTE) LIMITED

Address Type :

Local

Local Address (\* if Address Type is Local Address)

Postal Code : **068804**

Block/House No. : **2**

Street Name : **SHENTON WAY**

Unit : # **19 - 00**

Building/Estate Name : **SGX CENTRE 1**

Foreign Address (\* if Address Type is Foreign Address)

Address :

**Details of Shares Allotted** \* Please read instructions carefully before entering.

Note : If any share or shares is/are co-owned by 2 or more persons, please assign an alphabet e.g. A to denote the Group and enter the same in the box. Enter the same alphabet in the box for every allottee in the same group. Skip this box if share(s) are owned by only one person.

Group of Share that is co-owned:  
(Share Group)

If share(s) is/are co-owned, only one allottee is to enter details in (a), (b), (c), (d) and (e). Enter "0" (zero) for subsequent allottees in box (b) and leave blank for rest of the items.

a) Nominal Value per Share :

0.10

b) No. of shares allotted :

10400

c) Class of shares allotted :

Ordinary

d) Currency :

SINGAPORE DOLLAR (099)

e) Date of allotment :

28/09/2004 (dd/mm/yyyy)

Save

Reset

Back

**Return of Allotment of Shares**

Please fill in the following information. Fields marked \* must be completed.

<b>Resolution / Declaration</b>	<b>Share payable in cash</b>	<b>For a consideration other than cash</b>	<b>Share Capital / Allottees Particulars</b>	<b>List of Shareholders after Allotment</b>	<b>Summary of Capital</b>
-------------------------------------	----------------------------------	--	--	---	-------------------------------

**List of Allottees and their particulars****Identification****No./Registration Name  
No.****Shareholder Category**

198003912M	THE CENTRAL DEPOSITORY (PTE) LIMITED	Company / Foreign Branch
------------	---	--------------------------

If No. of shareholders exceeds 50, total No. of issued shares held by the remaining shareholders are :

	<b>Ordinary</b>	<b>Preference</b>	<b>Others</b>
<b>No. of Shares</b>	0	0	0

**Return of Allotment of Shares**

Submit

Please fill in the following information. Fields marked \* must be completed.

Resolution / Declaration	Share payable in cash	For a consideration other than cash	Share Capital / Allottees Particulars	List of Shareholders after the allotment	Summary of Capital
<b>Share Capital (1)</b>					
Currency :	<b>SINGAPORE DOLLAR (099)</b>				
Nominal Value per Share :	<b>0.10</b>				
Amount of Authorised Share Capital :	<b>200000000.00</b>				
Class of Shares :	Ordinary	Preference	Others		
Amount of Issued Share Capital :	<b>102367277.50</b>	<b>0.00</b>	<b>0.00</b>		
Amount of Paid-up Share Capital :	<b>102367277.50</b>	<b>0.00</b>	<b>0.00</b>		

**RECEIPT**

Receipt No : ACR0000000877433A

Date/Time : 04/10/2004 09:32

Transaction No : C040450491

Agency : RCB - RCB

Application : BIZFILE PAYMENT SERVICE

Paid via : Deposit Service Account

EP Ref No :

**SINGAPORE AIRPORT TERMINAL SERVICES LIMITED**  
**20 AIRPORT BOULEVARD**  
**SATS INFLIGHT CATERING CENTRE 3**  
**SINGAPORE 819659**

---

<b>Sno Code/Description</b>	<b>Unit Price (\$)</b>	<b>Qty</b>	<b>Amount</b>
1 Lodgment Of Return Of Allotment Of Share	10.00	1	10.00
<b>COMPANY NAME :</b> 197201770G / SINGAPORE AIRPORT TERMINAL SERVICES LIMITED			
<b>Total (\$):</b>			<b>10.00</b>

---

**Deposit Service Account No. : 030066**  
**Balance Amount in Deposit Account : \$ 565.00**

This is a computer-generated receipt. No signature is required.

Please print a copy of the receipt for your reference.

[HOME](#)[LOGOUT](#)



**Return of Allotment of Shares****Submit**

Please fill in the following information. Fields marked \* must be completed.

Resolution/Declaration	Shares payable in cash	For a consideration other than cash	Share Capital/Allottees Particulars	List of Shareholders after the allotment	Summary of Capital
------------------------	---------------------------	---	---	---	-----------------------

**Record saved successfully.****Company Type**

Please click on appropriate button :

- company is listed on the securities exchange ✓
- company is an unlisted public company
- company is a private company

**Power under Section 161 of the Companies Act \***

The directors have obtained the approval of the company in  Yes  No general meeting to issue shares.

**Resolution Made**

\* You are only required to fill in this section if the directors are not given the power under Section 161 of the Companies Act to issue shares.

Registration No. : **197201770G**

Company Name : **SINGAPORE AIRPORT TERMINAL SERVICES LIMITED**

Nature of Meeting : \*

Place of Meeting : \*

Date of Meeting : \*  (dd/mm/yyyy)

Resolution Type : \*

Description : \* (max 2000 characters)

Attachment : \* (copy of resolution)

**Note :**  **Browse...**

Uploaded file name will be changed by suffixing time-stamp with the actual file name as **filenameyyyyMMddmmsstt**

(Click 'Browse' to select file for attachment)

### Persons signing the resolution

Please indicate the directors/ secretaries who signed the resolution :

- S0036442H / OW CHIN HOCK
- S0070715E / NG KEE CHOE
- S0234645A / CHEW CHOON SENG
- S1001765C / BARRY HENRY PATRICK DESKER
- S1069567H / TAN JIAK NGEE MICHAEL
- S1673157I / YIP WAI PING ANNABELLE
- S1852301I / HONG HAI @ HUANG HAI
- S2163476Z / CHENG WAI WING EDMUND
- S2580327B / RICHARD CHARLES HELFER

Please enter names of other corporate representatives who signed the resolution, if applicable :

### Declaration

I, LIM HONG ENG SUSANNA, Professional body/service bureau, declare the information which has been submitted herein to be true to the best of my knowledge.

**Return of Allotment of Shares****Submit**

Please fill in the following information. Fields marked \* must be completed.

Resolution / Declaration	Share payable in cash	For a consideration other than cash	Share Capital / Allottees Particulars	List of Shareholders after the Allotment	Summary of Capital
<b>Authorised Capital</b>					
	Amount		Nominal Value per Share	Currency	
Authorised Capital :	<b>200000000</b>		<b>.1</b>	<b>SINGAPORE DOLLAR ( 099 )</b>	

Description of discrepancy :

**Return of Allotment of Shares (Payable in cash) \***

Applicable only if share is payable in cash

Class of Shares :	Ordinary	Preference	Others
Number of shares :	49400		
Amount paid or due and payable on each share			
paid :	0.10		
due and payable :	0		
Amount of premium paid or payable on each share :	1.70		

**Save** **Delete Issued Share** **Reset** **Back**

**Return of Allotment of Shares**

Submit

Please fill in the following information. Fields marked \* must be completed.

Resolution / Declaration	Share payable in cash	For a consideration other than cash	Share Capital / Allottees Particulars	List of Shareholders after the allotment	Summary of Capital
--------------------------	-----------------------	-------------------------------------	---------------------------------------	--	--------------------

**Particulars of Allottee**

Please indicate whether the allottee is an Individual : \*

- Allottee is an Individual  
 Allottee is NOT an Individual ✓

If Allottee is an Individual :

Shareholder Category : \* **Individual**Identification No. : \*  Retrieve DetailsIdentification Type : \* Name : \* Nationality : \* Mobile No : Occupation : Email Address : 
 Address Type : \*  
 Local  
 Foreign

Local Address (\* if Address Type is Local Address)

Postal Code :  Retrieve AddressBlock/House No. : Street Name : Unit : #  - Building/Estate Name : 

Foreign Address (\* if Address Type is Foreign Address)

Address : 

If Allottee is NOT an Individual :

Shareholder Category : \*  Search

Name : **THE CENTRAL DEPOSITORY (PTE) LIMITED**

Address Type : **Local**

Local Address (\* if Address Type is Local Address)

Postal Code : **068804**

Block/House No. : **2**

Street Name : **SHENTON WAY**

Unit : # **19 - 00**

Building/Estate Name : **SGX CENTRE I**

Foreign Address (\* if Address Type is Foreign Address)

Address :

**Details of Shares Allotted** \* Please read instructions carefully before entering.

Note : If any share or shares is/are co-owned by 2 or more persons, please assign an alphabet e.g. A to denote the Group and enter the same in the box. Enter the same alphabet in the box for every allottee in the same group. Skip this box if share(s) are owned by only one person.

Group of Share that is co-owned:

If share(s) is/are co-owned, only one allottee is to enter details in (a), (b), (c), (d) and (e). Enter "0" (zero) for subsequent allottees in box (b) and leave blank for rest of the items.

a) Nominal Value per Share :

b) No. of shares allotted :

c) Class of shares allotted :

d) Currency :

e) Date of allotment :  (dd/mm/yyyy)

**Return of Allotment of Shares**[Submit](#)

Please fill in the following information. Fields marked \* must be completed.

Resolution / Declaration	Share payable in cash	For a consideration other than cash	Share Capital / Allottees Particulars	List of Shareholders after Allotment	Summary of Capital
-----------------------------	--------------------------	---	---	--	-----------------------

**List of Allottees and their particulars****Identification**

No./Registration No.	Name	Shareholder Category
-------------------------	------	----------------------

198003912M	THE CENTRAL DEPOSITORY (PTE) LIMITED	Company / Foreign Branch
------------	---	--------------------------

If No. of shareholders exceeds 50, total No. of issued shares held by the remaining shareholders are :

No. of Shares	Ordinary	Preference	Others
	0	0	0

**Return of Allotment of Shares****Submit**

Please fill in the following information. Fields marked \* must be completed.

Resolution / Declaration	Share payable in cash	For a consideration other than cash	Share Capital / Allottees Particulars	List of Shareholders after the allotment	Summary of Capital
--------------------------	-----------------------	-------------------------------------	---------------------------------------	--	--------------------

**Share Capital (1)**

Currency :	<b>SINGAPORE DOLLAR (099)</b>		
Nominal Value per Share :	<b>0.10</b>		
Amount of Authorised Share Capital :	<b>200000000.00</b>		
Class of Shares :	Ordinary	Preference	Others
Amount of Issued Share Capital :	<b>102366237.50</b>	<b>0.00</b>	<b>0.00</b>
Amount of Paid-up Share Capital :	<b>102366237.50</b>	<b>0.00</b>	<b>0.00</b>

GST No. :M9-0008879-T

**RECEIPT**

Receipt No : ACR0000000878275A

Date/Time : 04/10/2004 14:12

Transaction No : C040451302

Agency : RCB - RCB

Application : BIZFILE PAYMENT SERVICE

Paid via : Deposit Service Account

EP Ref No :

**SINGAPORE AIRPORT TERMINAL SERVICES LIMITED**  
**20 AIRPORT BOULEVARD**  
**SATS INFLIGHT CATERING CENTRE 3**  
**SINGAPORE 819659**

Sno Code/Description	Unit Price (S\$)	Qty	Amount
1 Lodgment Of Notice Of Appointment / Cessation Of Appointment <b>COMPANY NAME :</b> 198500562G / SATS CATERING PTE LTD	10.00	1	10.00
Total (S\$) :			10.00

**Deposit Service Account No. : 030066**  
**Balance Amount in Deposit Account : \$ 535.00**

This is a computer-generated receipt. No signature is required.

Please print a copy of the receipt for your reference.

[HOME](#)[LOGOUT](#)



**Change of Particulars of Company's Directors, Managers, Secretaries and Auditors**

Please fill in the following information. Fields marked \* must be completed.

**Company Information**

Registration No : **198500562G**  
 Company Name : **SATS CATERING PTE LTD**

**List of Directors, Managing Directors, Secretaries, Managers** (click on hyperlink to edit information of officer)

S/No	Identification No. of Officer	Name of Officer
1	S0019405J	KARMJIT SINGH
2	S1408098H	NG CHIN HWEE
3	S1673157I	YIP WAI PING ANNABELLE
4	S1792374I	SHIREENA JOHAN WOON
5	S7003755F	LING DAW CHEE JOSEPH

To Report Appointment of New Officer [Officer](#)**List of Alternate Directors** (click on hyperlink to edit information of alternate director)

S/No	Identification No. of Alternate Director	Name of Alternate Director
------	--	----------------------------

To Report Appointment of New Alternate Director [Alternate Director](#)**List of Audit Firm** (click on hyperlink to edit information of audit firm)

S/No	Audit Firm No.	Name of Audit Firm
1	000418	ERNST & YOUNG

To Report Appointment of New Audit Firm [Audit Firm](#)[Submit](#)

**Change of Particulars of Company's Directors, Managers, Secretaries and Auditors****- Appointment of Company Officer**

Please fill in the following information. Fields marked \* must be completed.

**Particulars of Company Officer**Identification No. : \*  Identification Type : \*  Name of Officer : \* Nationality : \*  Mobile No. : Email Address : 

Address : \*

Address Type :  Local  
 Foreign

Local Address (\* if Address Type is Local Address)

Postal Code :  Block/House No. :  Street Name : **WATTEN HEIGHTS**Unit : #  - Building/Estate Name : **WATTEN ESTATE**

Foreign Address (\* if Address Type is Foreign Address)

Address :

**Change of Particulars of Company's Directors, Managers, Secretaries and Auditors****- Position Held by Company Officer**

Please fill in the following information. Fields marked \* must be completed.

**Position(s) Held by Company Officer**

Position Held : \*

Appointment Date : \*  (dd/mm/yyyy)

Date Appointment ceases :  (dd/mm/yyyy)

<a href="#">Save</a>	<a href="#">Reset</a>	<a href="#">Back</a>
----------------------	-----------------------	----------------------

**Change of Particulars of Company's Directors, Managers, Secretaries and Auditors**

Please fill in the following information. Fields marked \* must be completed.

**Company Information**

Registration No : **198500562G**  
Company Name : **SATS CATERING PTE LTD**

**List of Directors, Managing Directors, Secretaries, Managers** (click on hyperlink to edit information of officer)

<b>S/No</b>	<b>Identification No. of Officer</b>	<b>Name of Officer</b>
1	S0387618G	CHEW KHIAM SOON JOSEPH
2	S1408098H	NG CHIN HWEE
3	S1673157I	YIP WAI PING ANNABELLE
4	S1792374I	SHIREENA JOHAN WOON
5	S7003755F	LING DAW CHEE JOSEPH

To Report Appointment of New Officer

**List of Alternate Directors** (click on hyperlink to edit information of alternate director)

<b>S/No</b>	<b>Identification No. of Alternate Director</b>	<b>Name of Alternate Director</b>
-------------	---	-----------------------------------

To Report Appointment of New Alternate Director

**List of Audit Firm** (click on hyperlink to edit information of audit firm)

<b>S/No</b>	<b>Audit Firm No.</b>	<b>Name of Audit Firm</b>
1	000418	ERNST & YOUNG

To Report Appointment of New Audit Firm

**Change of Particulars of Company's Directors, Managers, Secretaries and Auditors****- Cessation of Company Officer**

Please fill in the following information. Fields marked \* must be completed.

**Record saved successfully.**

**Position(s) Held by Company Officer**

**Position Held :** DIRECTOR

**Appointment Date :** 01/02/2000

**Cessation Date : \*** 01/10/2004 (dd/mm/yyyy)  
(Date of Change)

**Reason for Cessation : \*** Resigned

<a href="#">Save</a>	<a href="#">Reset</a>	<a href="#">Back</a>
----------------------	-----------------------	----------------------